

## ISA-PLAN® - SMD Präzisionswiderstände / SMD precision resistors

TECHNISCHE DATEN / TECHNICAL DATA		
Widerstandswerte	Resistance values	2 - 500 mOhm
Toleranz	Tolerance	1 %, 2 %, 5 %
Temperaturkoeffizient	Temperature coefficient	< 30 ppm/K (20 °C bis/to 60 °C)
Temperaturbereich	Applicable temperature range	-55 °C bis/to +170 °C
Belastbarkeit	Load capacity	5 W
Innerer Wärmewiderstand ( $R_{thi}$ )	Internal heat resistance ( $R_{thi}$ )	< 8 K/W
Isolationsspannung	Dielectric withstanding voltage	100 VAC
Induktivität	Inductance	< 10 nH
Stabilität (Nennlast) Abweichung $T_K$ = Kontaktstellentemperatur / Stability (Nominal load) deviation $T_K$ = Terminal temperature		< 0.5 % nach/after 2000 h ( $T_K$ = 100 °C) < 1 % nach/after 2000 h ( $T_K$ = 130 °C)

### MERKMALE / FEATURES

- 5 W Dauerleistung  
5 W permanent power
- Dauerströme bis 50 A (2 mOhm)  
Constant current up to 50 A (2 mOhm)
- 4-Leiter-Messwiderstand  
4-terminal-resistor
- Hybridmontage  
Hybrid assembly
- Vergoldete Bondflächen  
Au-plated bond pads
- Vergoldete Bauteilrückseite  
Reverse side covered with gold flash
- Geeignet für Löttemperaturen bis 280 °C / 30 sek  
oder 250 °C / 5 min  
Max. solder temperature up to 280 °C / 30 sec  
or 250 °C / 5 min
- Bauteilmontage: Reflow-Löten und Kleben auf Substrat  
Mounting: Reflow-soldering and epoxy attachment on substrate

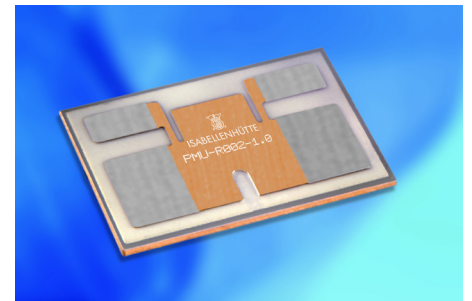

Bauform/Size 3924

### APPLIKATIONEN / APPLICATION

- Messwiderstand für Leistungshybride  
Current sensor for power hybrid applications
- Frequenzumrichter  
Frequency converters
- Leistungsmodul  
Power modules

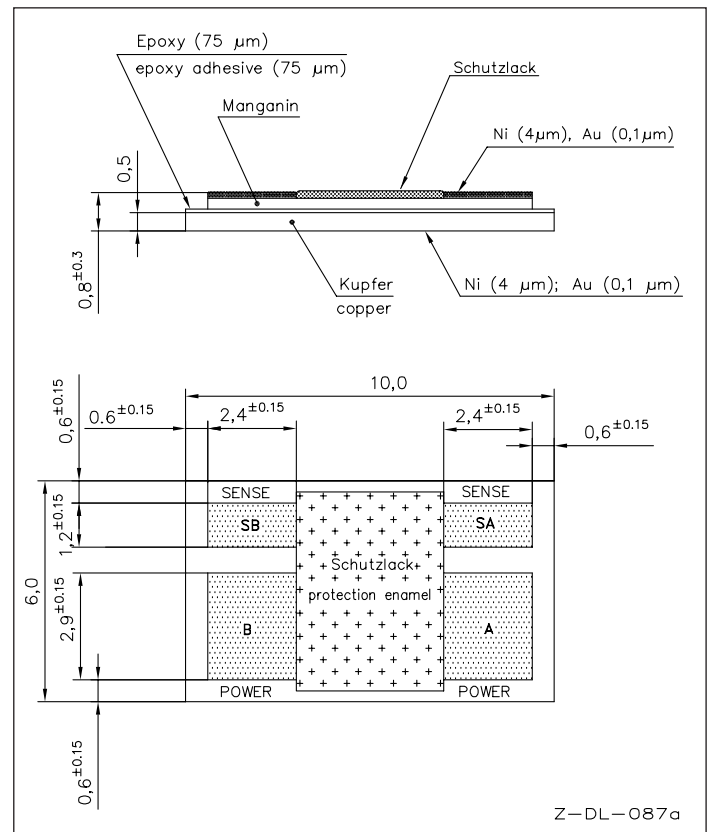

Abmessungen [mm] / Dimensions [mm]

## TK, Lastminderung und Langzeitstabilität / TCR, power derating and long term stability

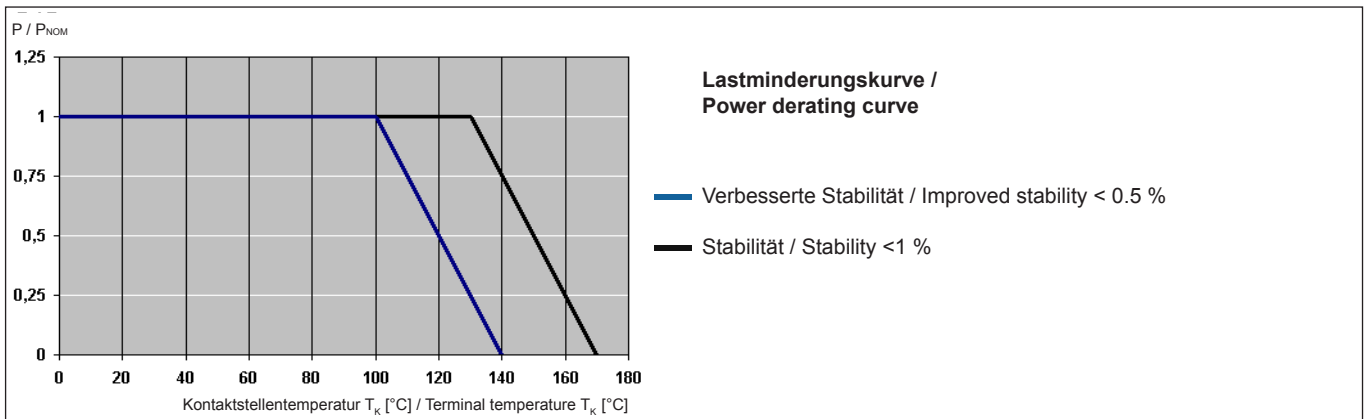
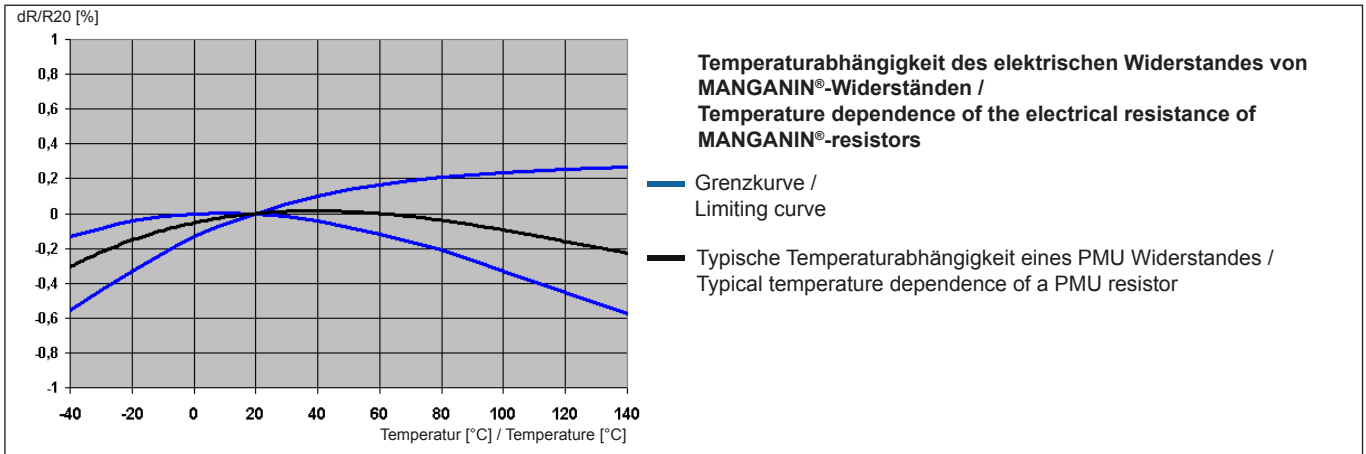

## Vorschlag für die Gestaltung der Löt- und Bondpads / Proposal for solder and bond pad design

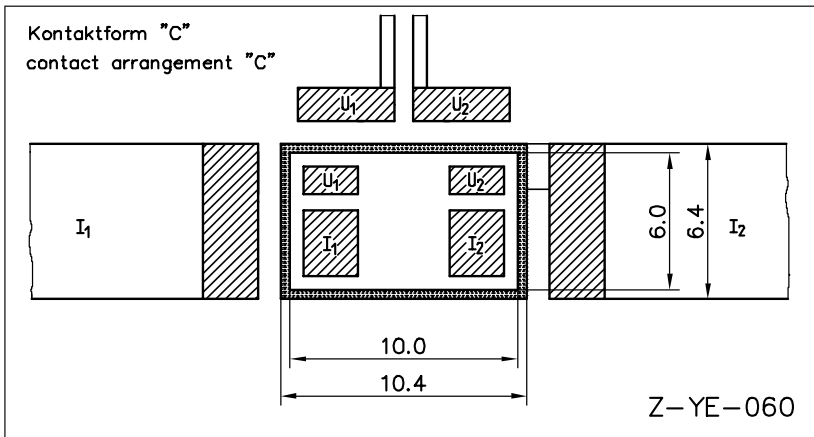

Abmessungen [mm] / Dimensions [mm]

Lötprofil Vorschlag / Recommended solder profile			
Reflow-, IR-löten / Reflow-, IR-soldering			
Temperatur / Temperature [°C]	260	255	217
Zeit / Time [s]	peak	40	90

<b>RoHS 2002/95/EG konform seit Produktstart</b>	
Ausführliche Informationen erhalten Sie auf unserer Homepage: <a href="http://www.isabellenhuette.de">www.isabellenhuette.de</a>	
<b>RoHS 2002/95/EC compliance since product launch</b>	
For more information please visit our website: <a href="http://www.isabellenhuette.de">www.isabellenhuette.de</a>	

GURTINFORMATIONEN / TAPE & REEL INFORMATION	
Norm / Specification	DIN EN 60286-3
Gurtbreite / Tape width	16 mm
Anzahl Bauteile / Parts per reel	3000

BESTELLBEZEICHNUNG / ORDERING CODE			
<b>PMU-C-R002-1.0</b>			
Typ / Type	Layout	Widerstandswert / Resistance value	Toleranz / Tolerance
PMU	C	2 mOhm	1.0 %

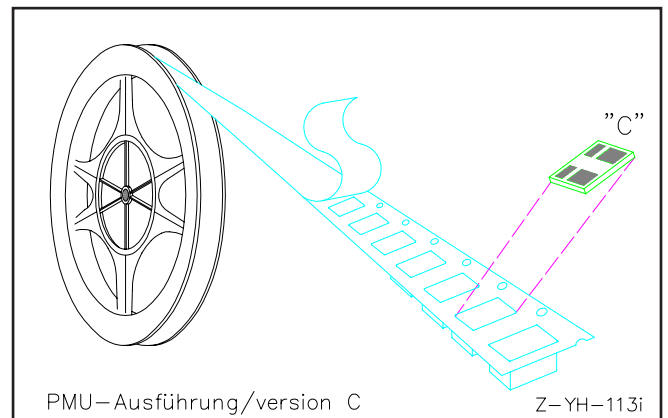

### Gewährleistung

Alle Angaben über Eignung, Verarbeitung und Anwendung unserer Produkte, technische Beratung und sonstige Angaben erfolgen nach bestem Wissen, befreien den Käufer jedoch nicht von eigenen Prüfungen und Versuchen.

### Warranty

All information regarding the suitability, workability and applicability of our products, all technical advice and other information are provided to the best of our knowledge and belief, but shall not discharge the buyer from his own examinations and tests.

## Grenzkurve für maximale Pulsenergie bzw. Pulsleistung für Dauerbetrieb / Maximum pulse energy respectively pulse power for continuous operation

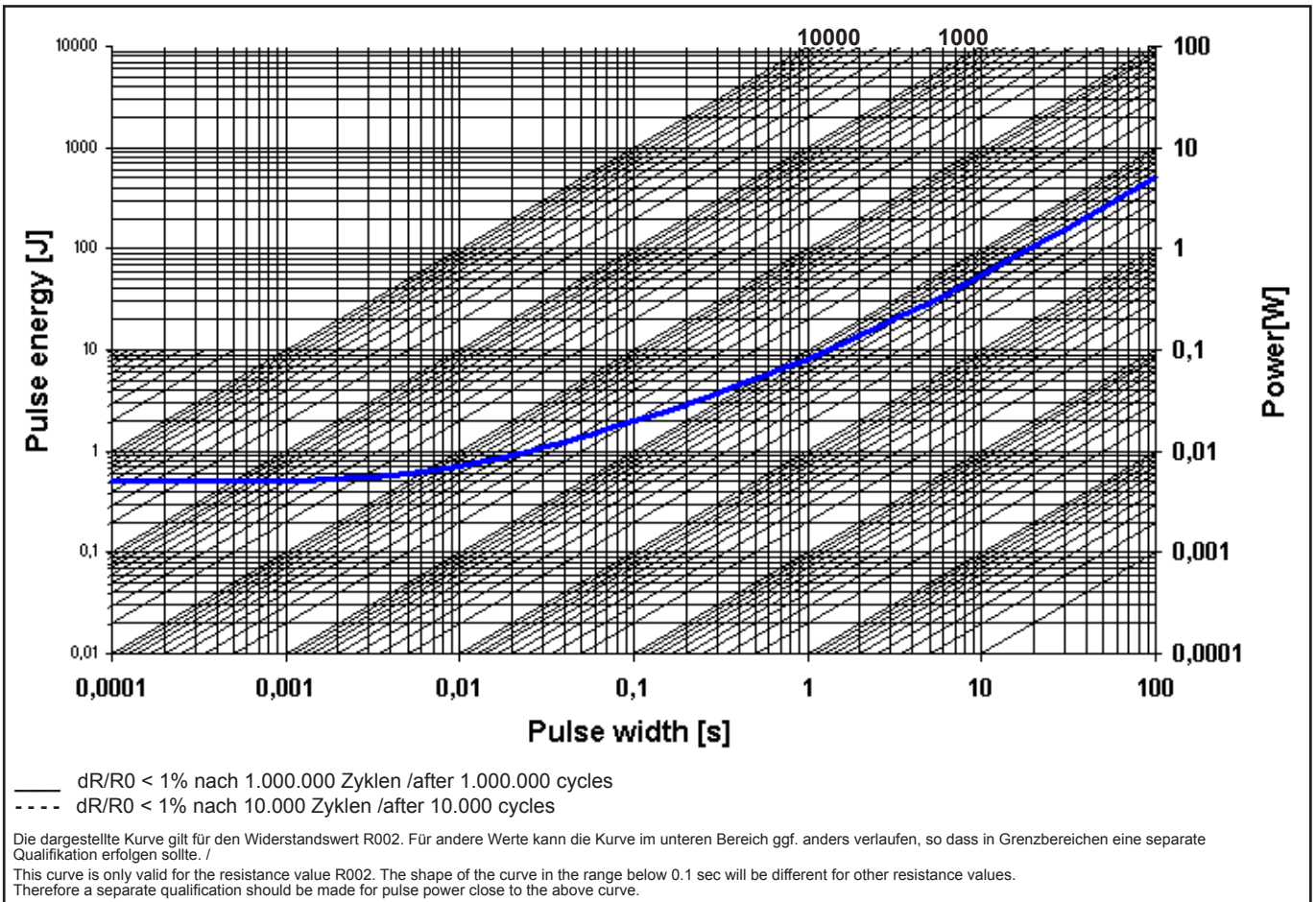

Spezifikation / Specification			
Parameters	Test Conditions	Specification	Typical data
Maximum Temperature for full power operation	120 °C	120 °C	130 °C
Working Temperature	-55 to 170 °C	-55 to 170 °C	-55 to 170 °C
Thermal Shock	MIL-STD-202 method 107-B1	0.1 %	0.05 %
Overload	MIL-R-26E (5 times rated power, 5 sec)	0.2 %	0.1 %
Solderability	MIL-STD-202 method 208	> 95 % coverage	99 %
Resistance to Solvents	MIL-STD-202 method 215, 2.1a, 2.1d	no damage	no damage
Low Temperature Storage and Operation	MIL-STD-26E	0.1 %	0.05 %
Resistance to Soldering Heat	MIL-STD-202 method 210	0.1 %	0.05 %
Moisture Resistance	MIL-STD-202 method 106	0.1 %	0.03 %
Shock	MIL-STD-202 method 213-A	0.2 %	0.1 %
Vibration, High Frequency	MIL-STD-202 method 204-B	0.2 %	0.1 %
Life	MIL-STD-26E	0.2 %	0.15 %
Storage Life at Elevated Temperature	MIL-STD-202 method 108-F	0.3 %	0.2 %
High Temperature Exposure	140 °C, 2000 h	0.2 %	0.2 %
Current Noise	MIL-STD-202 method 308	0.01 %	0.005 %
Voltage Coefficient (%/V)	MIL-STD-202 method 309	linearity error less than 120dB	
Resistance Temperature Characteristic	MIL-STD-202 method 304 (20-60°C)	<30 ppm/K	<30 ppm/K
Thermal EMF	0 - 100 °C	2 $\mu$ V/K max.	<1 $\mu$ V/K
Frequency Characteristic	inductivity	< 10 nH	<10 nH