

Programmable Dual RS-232/RS-485 Transceiver

- +5V Only Operation
- Software Programmable RS-232 or RS-485 Selection
- Four RS-232 Transceivers in RS-232 Mode
- Two RS-485 Full-Duplex Transceivers in RS-485 Mode
- Two RS-232 Transceivers and One RS-485 Transceiver in Dual Mode
- Self-Testing Loopback Mode
- Full Driver Tri-State (Hi-Z) Control
- Ideal for RS-232 to RS-485 conversion

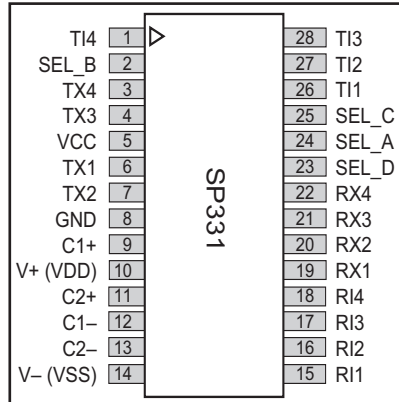

DESCRIPTION

The SP331 is a programmable RS-232 and/or RS-485 transceiver IC. The SP331 contains four drivers and four receivers when selected in RS-232 mode; and two drivers and two receivers when selected in RS-485 mode. The SP331 also contains a dual mode which has two RS-232 drivers/receivers plus one differential RS-485 driver/receiver.

The RS-232 transceivers can typically operate at 230kbps while adhering to the RS-232 specifications. The RS-485 transceivers can operate up to 10Mbps while adhering to the RS-485 specifications. The SP331 includes a self-test loopback mode where the driver outputs are internally configured to the receiver inputs. This allows for easy diagnostic serial port testing without using an external loopback plug. The RS-232 and RS-485 drivers can be disabled (High-Z output) by controlling a set of four select pins.

TYPICAL APPLICATIONS CIRCUIT

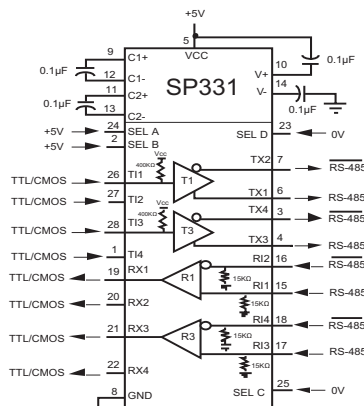

ABSOLUTE MAXIMUM RATINGS

These are stress ratings only and functional operation of the device at these ratings or any other above those indicated in the operation sections of the specifications below is not implied. Exposure to absolute maximum rating conditions for extended periods of time may affect reliability.

V _{CC}	+7V
Input Voltages	
Logic.....	-0.5V to (V _{CC} +0.5V)
Drivers.....	-0.5V to (V _{CC} +0.5V)
Receivers.....	+/-30V @ ≤100mA
Driver Outputs.....	+/-15V
Maximum Data Rate.....	8Mbps (Note 1)

Storage Temperature.....	-65°C to +150°C
Power Dissipation	
28-pin WSOIC.....	1000mW
Package Derating:	
28-pin WSOIC	
θ _{JA}	40 °C/W

SPECIFICATIONS

Limits are specified at T_A = 25°C and V_{CC} = +5.0V unless otherwise noted.

PARAMETER	MIN.	TYP.	MAX.	UNITS	CONDITIONS
LOGIC INPUTS					
V _{IL}			0.8	Volts	
V _{IH}	2.0			Volts	
LOGIC OUTPUTS					
V _{OL}			0.4	Volts	I _{OUT} = -3.2mA
V _{OH}	2.4			Volts	I _{OUT} = 1.0mA
RS-232 DRIVER					
DC Characteristics					
HIGH Level Output	+5.0		+15.0	Volts	R _L = 3kΩ, V _{IN} = 0.8V
LOW Level Output	-15.0		-5.0	Volts	R _L = 3kΩ, V _{IN} = 2.0V
Open Circuit Voltage	-15		+15	Volts	
Short Circuit Current			+/-100	mA	V _{OUT} = 0V
Power Off Impedance	300			Ω	V _{CC} = 0V, V _{OUT} = +/-2.0V
AC Characteristics					
Slew Rate			30	V/μs	R _L = 3kΩ, C _L = 50pF; V _{CC} = +5.0V, T _A @ 25°C
Transistion Time			1.5	μs	R _L = 3kΩ, C _L = 2500pF; between +/-3V, T _A @ +25°C
Maximum Data Rate	120	235		kbps	R _L = 3kΩ, C _L = 2500pF
Propagation Delay t _{PHL}		2	8	μs	Measured from 1.5V of V _{IN} to 50% of V _{OUT} ; R _L = 3kΩ
Propagation Delay t _{PLH}		2	8	μs	
RS-232 RECEIVER					
DC Characteristics					
HIGH Threshold		1.7	3.0	Volts	
LOW Threshold	0.8	1.2		Volts	
Receiver Open Circuit Bias			+2.0	Volts	
Input Impedance	3	5	7	kΩ	V _{IN} = +15V to -15V

www.BDTIC.com/Exar/

SPECIFICATIONS

Limits are specified at $T_A = 25^\circ\text{C}$ and $V_{CC} = +5.0\text{V}$ unless otherwise noted.

PARAMETER	MIN.	TYP.	MAX.	UNITS	CONDITIONS
RS-232 RECEIVER (continued)					
AC Characteristics					
Maximum Data Rate	120	235		kbps	
Propagation Delay t_{PHL}		0.25	1	μs	Measured from 50% of V_{IN} to 1.5V of V_{OUT}
Propagation Delay t_{PLH}		0.25	1	μs	
RS-485 DRIVER					
DC Characteristics					
Open Circuit Voltage			6.0	Volts	
Differential Output	1.5		5.0	Volts	$R_L = 54\Omega$, $C_L = 50\text{pF}$
Balance			+/-0.2	Volts	$ V_T - \overline{V_T} $
Common-Mode Output			3.0	Volts	
Output Current	28.0			mA	$R_L = 54\Omega$
Short Circuit Current			+/-250	mA	Terminated in -7V to +10V
AC Characteristics					
Maximum Data Rate	10			Mbps	$R_L = 54\Omega$
Maximum Data Rate			8	Mbps	$T_A = +85^\circ\text{C}$, Note 1
Output Transition Time		30	50	ns	Rise/Fall time, 10%-90%
Propagation Delay t_{PHL}		80	120	ns	See Figures 2 & 4, $R_{DIFF} = 54\Omega$, $C_{L1} = C_{L2} = 100\text{pF}$
Propagation Delay t_{PLH}		80	120	ns	
Driver Output Skew		10	20	ns	Per Figure 4, $t_{SKEW} = t_{PHL} - t_{PLH} $
RS-485 RECEIVER					
DC Characteristics					
Common Mode Range	-7.0		+12	Volts	
Receiver Sensitivity		+/-0.2	+/-0.3	Volts	$-7\text{V} \leq V_{CM} \leq +12\text{V}$
Input Impedance	12	15		k Ω	$-7\text{V} \leq V_{CM} \leq +12\text{V}$
AC Characteristics					
Maximum Data Rate	10			Mbps	
Maximum Data Rate			8	Mbps	$T_A = +85^\circ\text{C}$, Note 1
Propagation Delay t_{PHL}		130	200	ns	See Figures 2 & 6, $R_{DIFF} = 54\Omega$, $C_{L1} = C_{L2} = 100\text{pF}$
Propagation Delay t_{PLH}		130	200	ns	
Differential Receiver Skew		10	20	ns	$t_{SKEW} = t_{PHL} - t_{PLH} $, $R_{DIFF} = 54\Omega$, $C_{L1} = C_{L2} = 100\text{pF}$
ENABLE TIMING					
RS-485 DRIVER					
Enable Time (see Figures 3 and 5)					
Enable to LOW		90	150	ns	$C_L = 15\text{pF}$, S_1 Closed
Enable to HIGH		90	150	ns	$C_L = 15\text{pF}$, S_2 Closed
Disable Time (see Figures 3 and 5)					
Disable from LOW		80	120	ns	$C_L = 15\text{pF}$, S_1 Closed
Disable from HIGH		80	120	ns	$C_L = 15\text{pF}$, S_2 Closed

SPECIFICATIONS

Limits are specified at $T_A = 25^\circ\text{C}$ and $V_{CC} = +5.0\text{V}$ unless otherwise noted.

PARAMETER	MIN.	TYP.	MAX.	UNITS	CONDITIONS
POWER REQUIREMENTS					
Supply Voltage V_{CC}	+4.75		+5.25	Volts	
Supply Current I_{CC}					
No Load (T_x Disabled)		10	15	mA	SEL_A ► SEL_D = "0001"
No Load (RS-232 Mode)		15	30	mA	SEL_A ► SEL_D = "0000"
No Load (RS-485 Mode)		7	20	mA	SEL_A ► SEL_D = "1100"
ENVIRONMENTAL					
Operating Temperature					
Commercial ($_C_$)	0		70	$^\circ\text{C}$	
Industrial ($_E_$)	-40		+85	$^\circ\text{C}$	
Storage Temperature	-65		+150	$^\circ\text{C}$	

Note 1: Exceeding the maximum data rate of 8Mbps at $T_A = 85^\circ\text{C}$ may permanently damage the device

RECEIVER INPUT GRAPH

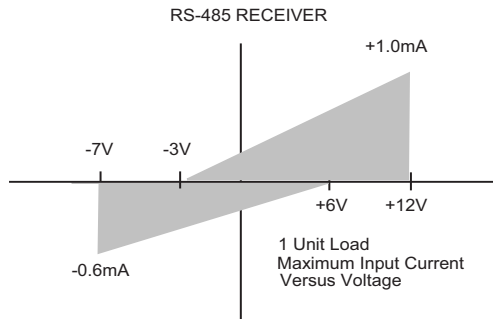

TEST CIRCUITS

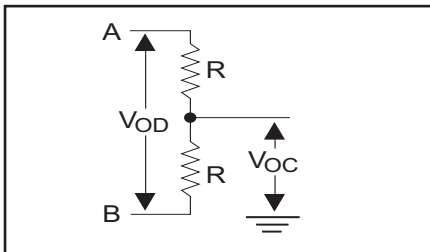

Figure 1. Driver DC Test Load Circuit

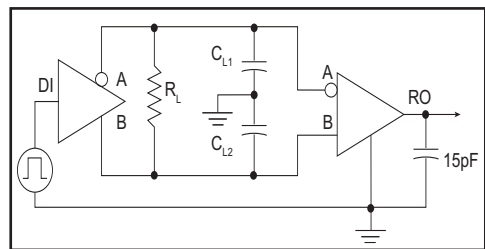

Figure 2. Driver/Receiver Timing Test Circuit

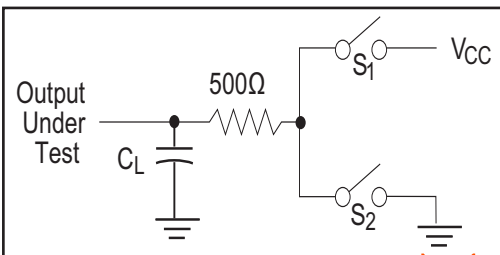

Figure 3. Driver Timing Test Load #2 Circuit

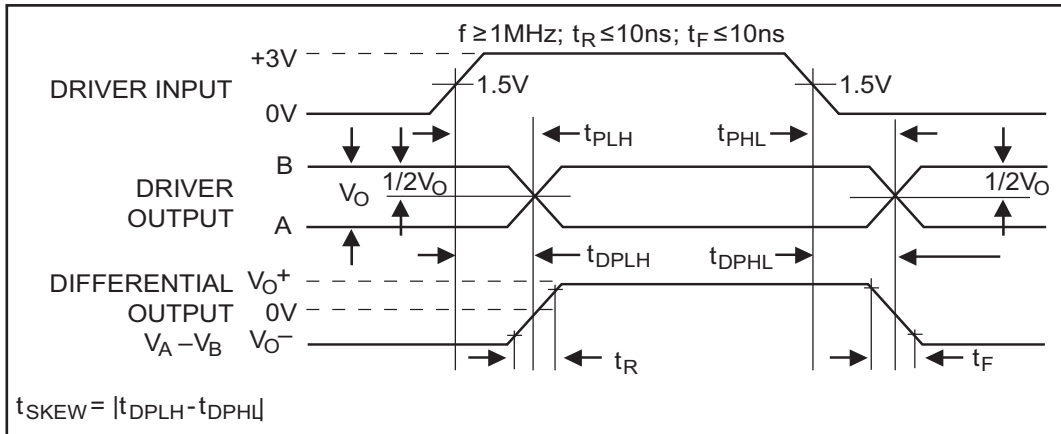

Figure 4. Driver Propagation Delays

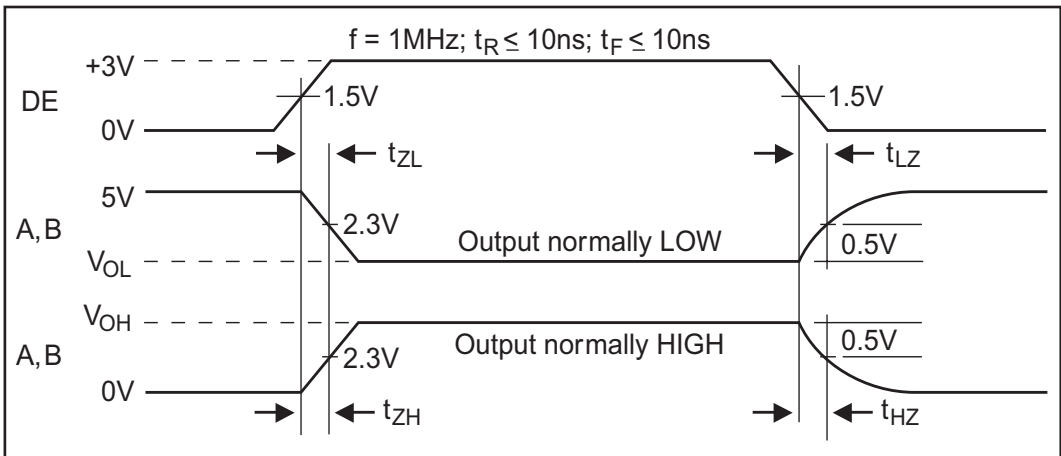

Figure 5. Driver Enable and Disable Times

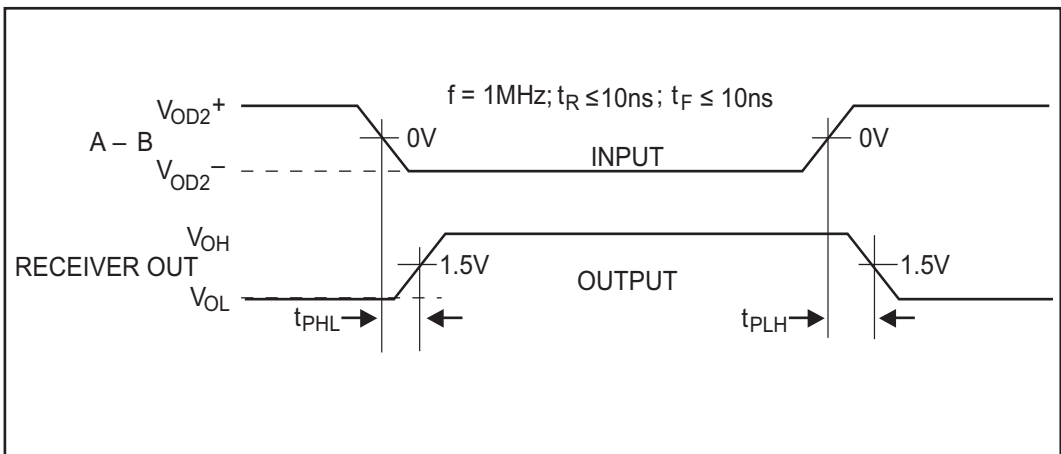

Figure 6. Receiver Propagation Delays

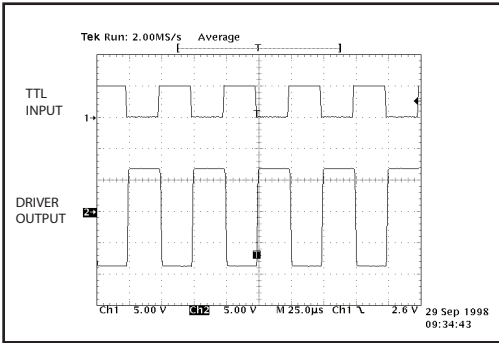

Figure 7. Typical RS-232 Driver Output

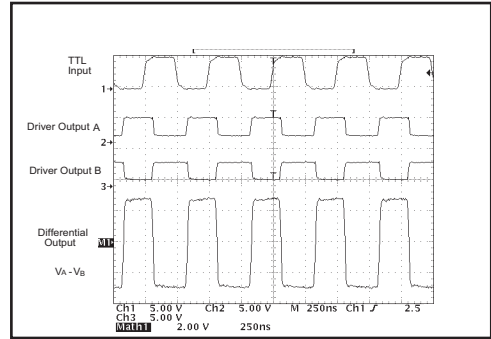

Figure 8. Typical RS-485 Driver Output

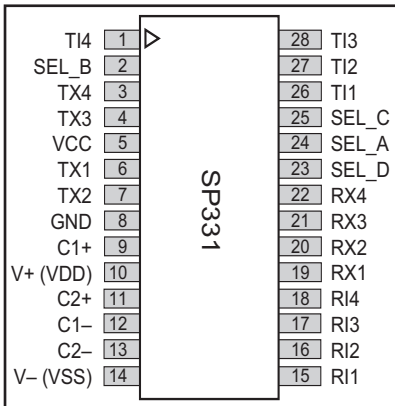

Figure 9. SP331 Pinout

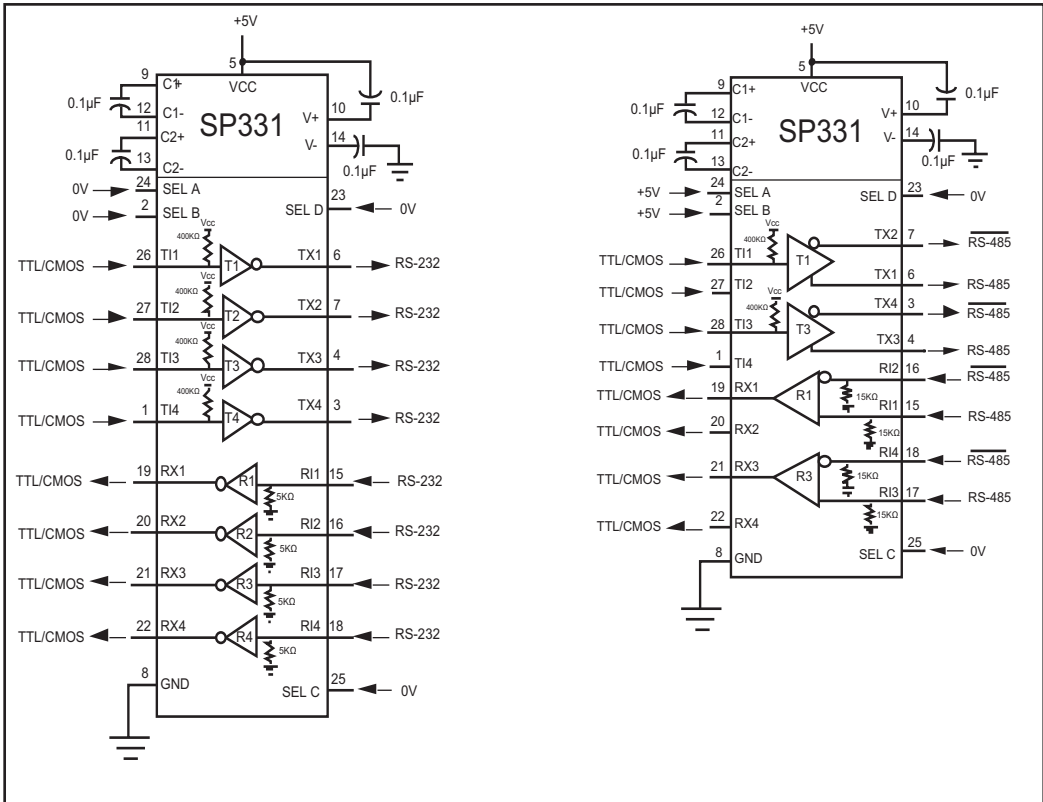

Figure 10. Typical Operating Circuit

FUNCTION TABLE FOR SELECT PINS

<u>A</u>	<u>B</u>	<u>C</u>	<u>D</u>	<u>MODE</u>	<u>FUNCTION</u>
0	0	0	0	RS-232	All four RS-232 drivers active
0	0	0	1	RS-232	All four RS-232 drivers tri-state
0	0	1	0	RS-232	All four RS-232 drivers tri-state
0	0	1	1	RS-232	RS-232 (4ch) Loopback
0	1	0	0	RS-232/RS-485	T1 and T2 active RS-232; T3 tri-state RS-485
0	1	0	1	RS-232/RS-485	T1 and T2 tri-state RS-232; T3 active RS-485
0	1	1	0	RS-232/RS-485	T1 and T2 active RS-232; T3 tri-state RS-485
0	1	1	1	RS-232/RS-485	RS-232 (2ch) / RS-485 (1ch) Loopback
1	0	0	0	RS-485/RS-232	T1 active RS-485; T3 and T4 active RS-232
1	0	0	1	RS-485/RS-232	T1 tri-state RS-485; T3 active RS-232; T4 active RS-232
1	0	1	0	RS-485/RS-232	All RS-485 and RS-232 drivers tri-state
1	0	1	1	RS-485/RS-232	RS-485 (1ch) / RS-232 (2ch) Loopback
1	1	0	0	RS-485	T1 and T3 active RS-485
1	1	0	1	RS-485	T1 tri-state RS-485; T3 active RS-485
1	1	1	0	RS-485	T1 active RS-485; T3 tri-state RS-485
1	1	1	1	RS-485	RS-485 (2ch) Loopback

Table 1. Mode Function Table. (Refer to Control Logic Confirmations for Block Diagrams)

THEORY OF OPERATION

The **SP331** is made up of four separate circuit blocks — the charge pump, drivers, receivers, and decoder. Each of these circuit blocks is described in more detail below.

Charge-Pump

The charge pump is a **Exar**-patented design (U.S. 5,306,954) and uses a unique approach compared to older less efficient designs. The charge pump still requires four external capacitors, but uses a four-phase voltage shifting technique to attain symmetrical 10V power supplies. Figure 15(a) shows the waveform found on the positive side of capacitor C₂, and Figure 15(b) shows the negative side of capacitor C₂. There is a free-running oscillator that controls the four phases of the voltage shifting. A description of each phase follows.

Phase 1

—V_{SS} charge storage — During this phase of the clock cycle, the positive side of capacitors C₁ and C₂ are initially charged to +5V. C₁⁺ is then switched to ground and charge

transferred to C₂⁻. Since C₂⁺ is connected to +5V, the voltage potential across capacitor C₂ is now 10V.

Phase 2

—V_{SS} transfer — Phase two of the clock connects the negative terminal of C₂ to the V_{SS} storage capacitor and the positive terminal of C₂ to ground, and transfers the generated -10V to C₃. Simultaneously, the positive side of capacitor C₁ is switched to +5V and the negative side is connected to ground.

Phase 3

—V_{DD} charge storage — The third phase of the clock is identical to the first phase — the charge transferred in C₁ produces -5V in the negative terminal of C₁, which is applied to the negative side of capacitor C₂. Since C₂⁺ is at +5V, the voltage potential across C₂ is 10V.

Phase 4

—V_{DD} transfer — The fourth phase of the clock connects the negative terminal of C₂

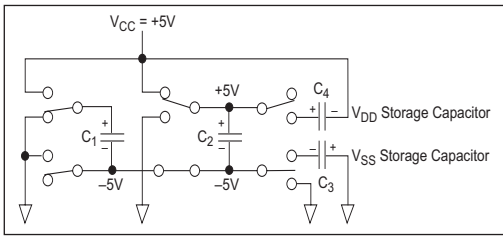

Figure 11. Charge Pump Phase 1.

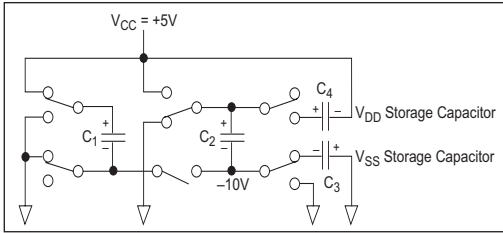

Figure 12. Charge Pump Phase 2.

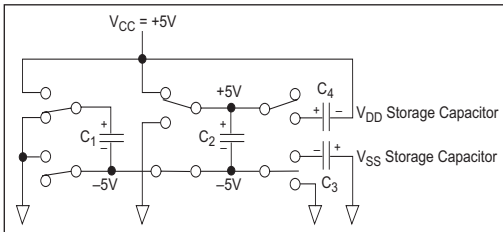

Figure 13. Charge Pump Phase 3.

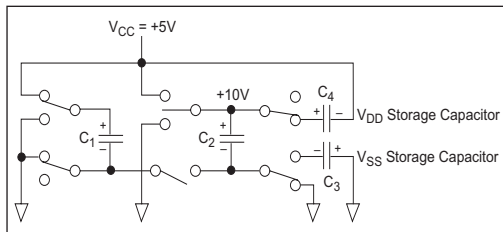

Figure 14. Charge Pump Phase 4.

to ground and transfers the generated 10V across C_2 to C_4 , the V_{DD} storage capacitor. Again, simultaneously with this, the positive side of capacitor C_1 is switched to +5V and the negative side is connected to ground, and the cycle begins again.

Since both V^+ and V^- are separately generated from V_{CC} in a no-load condition, V^+ and V^- will be symmetrical. Older charge pump approaches that generate V^- from V^+ will show a decrease in the magnitude of V^- compared to V^+ due to the inherent inefficiencies in the design.

The clock rate for the charge pump typically operates at 15kHz. The external capacitors must be $0.1\mu\text{F}$ with a 16V breakdown rating.

External Power Supplies

For applications that do not require +5V only, external supplies can be applied at the V^+ and V^- pins. The value of the external supply voltages must be no greater than $\pm 10\text{V}$. The current drain for the $\pm 10\text{V}$ supplies is used for RS-232. For the RS-232 driver the current requirement will be 3.5mA per driver. The external power supplies should provide a power supply sequence of +10V, then +5V, followed by -10V.

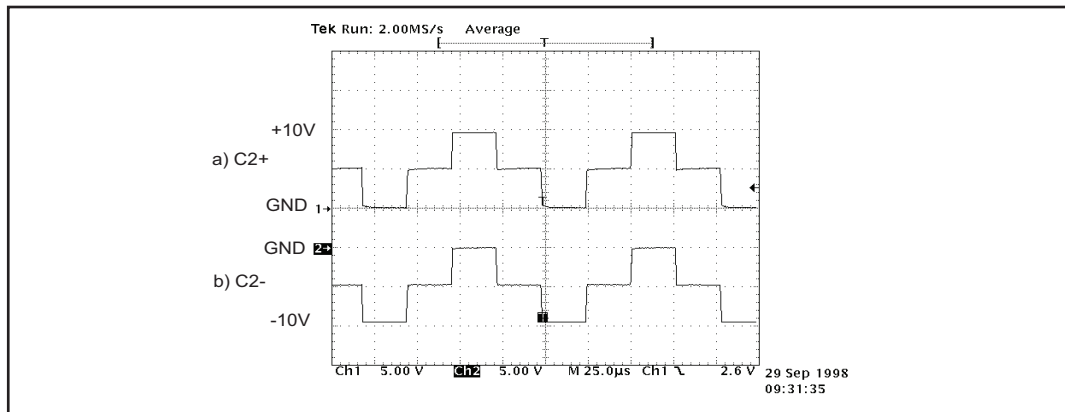

Figure 15. Charge Pump Waveforms

Drivers

The **SP331** has four independent RS-232 single-ended drivers and two differential RS-485 drivers. Control for the mode selection is done via a four-bit control word. The drivers are pre-arranged such that for each mode of operation the relative position and functionality of the drivers are set up to accommodate the selected interface mode. As the mode of the drivers is changed, the electrical characteristics will change to support the requirements of clock, data, and control line signal levels. Unused driver inputs can be left floating; however, to ensure a desired state with no input signal, pull-up resistors to +5V or pull-down resistors to ground are suggested. Since the driver inputs are both TTL or CMOS compatible, any value resistor less than 100k Ω will suffice.

When in RS-232 mode, the single-ended RS-232 drivers produce compliant RS-232E and ITU V.28 signals. Each of the four drivers output single-ended bipolar signals in access of $\pm 5V$ with a full load of 3k Ω and 2500pF applied as specified. These drivers can also operate at least 120kbps.

When programmed to RS-485 mode, the differential RS-485 drivers produce complaint RS-485 signals. Each RS-485 driver outputs a unipolar signal on each output pin with a magnitude of at least 1.5V while loaded with a worst case of 54 Ω between the driver's two output pins. The signal levels and drive capability of the RS-485 drivers allow the drivers to also comply with RS-422 levels. The transmission rate for the differential drivers is 10Mbps.

Receivers

The **SP331** has four single-ended receivers when programmed for RS-232 mode and two differential receivers when programmed for RS-485 mode.

Control for the mode selection is done via a 4-bit control word, as in the drivers. As the operating mode of the receivers is changed, the electrical characteristics will change to support the requirements of the appropriate serial standard. Unused receiver inputs can be left floating without causing oscillation. To ensure a desired state of the receiver

output, a pull-up resistor of 100k Ω to +5V should be connected to the inverting input for a logic low, or the non-inverting input for a logic high. For single-ended receivers, a pull-down resistor to ground of 5k Ω is internally connected, which will ensure a logic high output.

The RS-232 receiver has a single-ended input with a threshold of 0.8V to 2.4V. The RS-232 receiver has an operating voltage range of $\pm 15V$ and can receive signals up to 120kbps. RS-232 receivers are used in RS-232 mode for all signal types include data, clock, and control lines of the RS-232 serial port.

The differential RS-485 receiver has an input impedance of 15k Ω and a differential threshold of $\pm 200mV$. Since the characteristics of an RS-422 receiver are actually subsets of RS-485, the receivers for RS-422 requirements are identical to the RS-485 receivers. All of the differential receivers can receive data up to 10Mbps.

Select Mode Pins

Similar to our SP500 family of multiprotocol products, the **SP331** has the ability to change the configuration of the drivers and receivers via a 4-bit switch. Referring to Table 1; RS-232 mode, RS-485 mode, or two different combinations of RS-232/RS-485 can be configured using the SEL_A and SEL_B pins. The drivers can be put into tri-state mode by using the SEL_C and SEL_D pins. All receivers remain active during any tri-state condition of the drivers.

Loopback Mode

Loopback is invoked by asserting "xx11" into the select pins. In RS-232/RS-485 or RS-485/RS-232 loopback mode, the RS-232 driver outputs loop back into the RS-232 receiver inputs and the RS-485 differential driver loops back into the RS-485 receiver. During loopback, the driver outputs and receiver inputs are disconnected from the outside world. The driver outputs are in tri-state and the receiver inputs are disabled. The input impedance of the receivers during loopback is approximately 15k Ω to ground.

SP331 CONTROL LOGIC CONFIGURATION (Refer to Table 1)

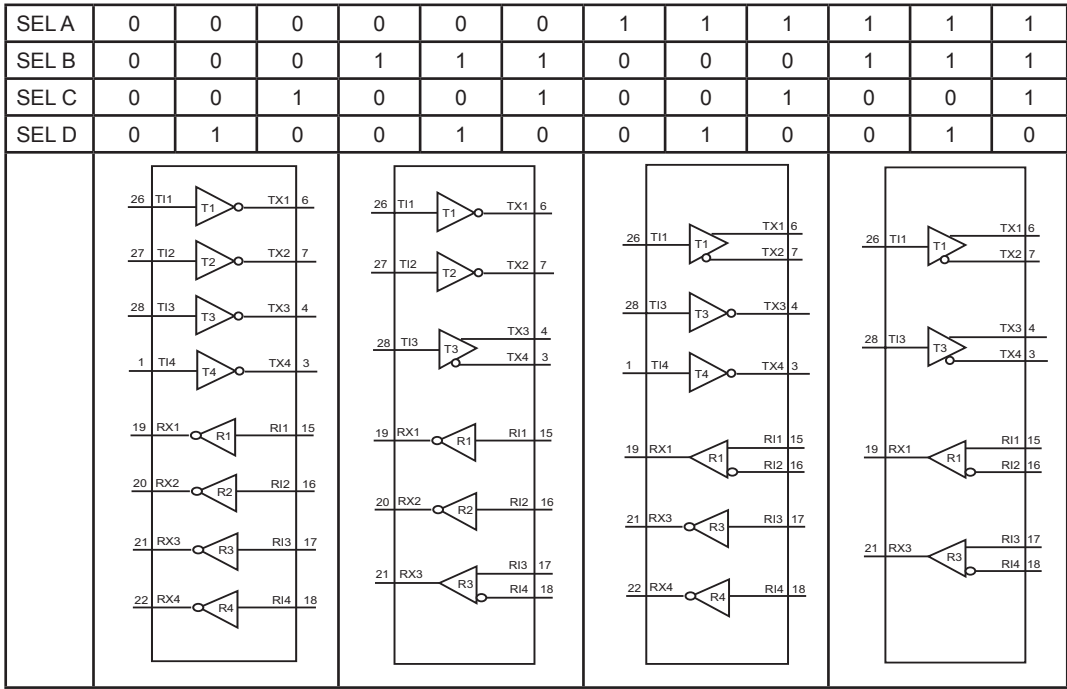

SP331 LOOPBACK (Refer to Table 1)

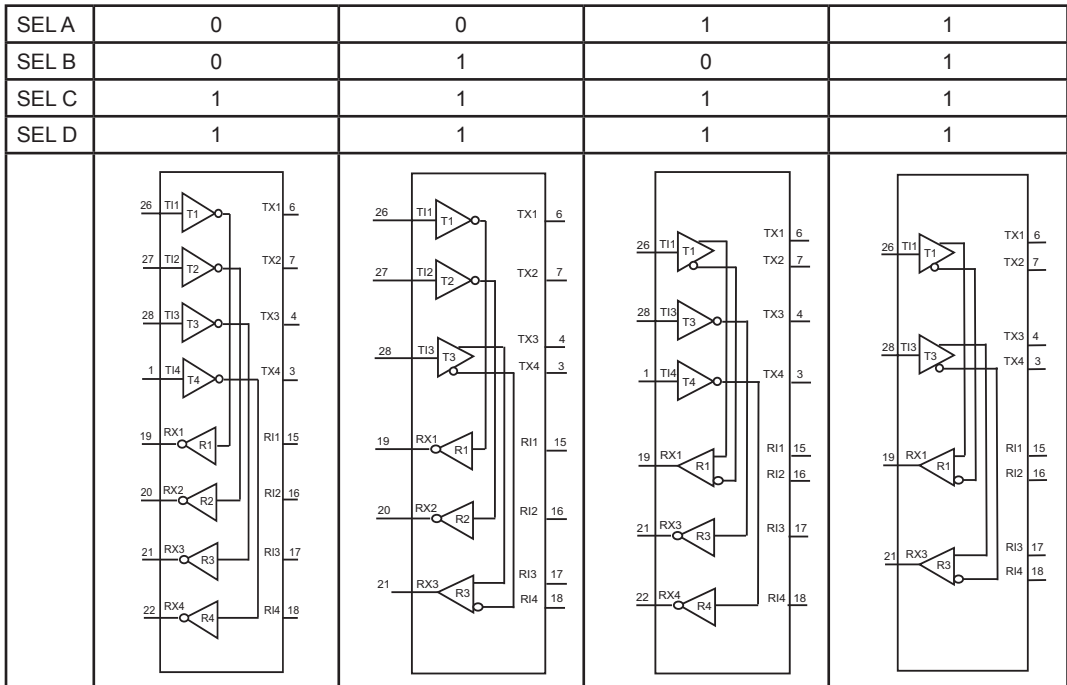

REVISION HISTORY			
REV.	DESCRIPTION	DATE	APP'D
A	DRAWING ORIENTATION	04/24/06	JL
B	CHANGE DRAWING LOGO AND COMPANY NAME	11/28/07	JL

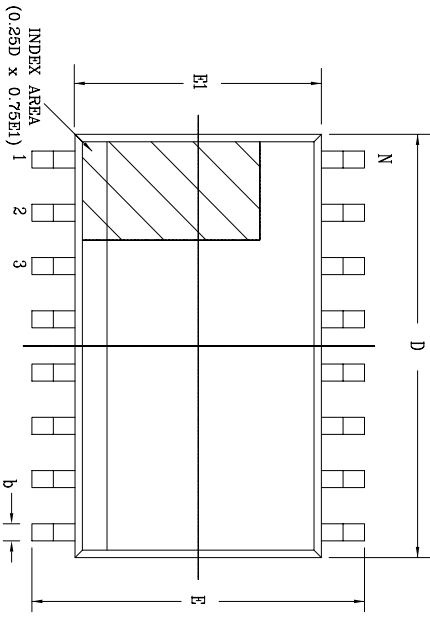

Top View

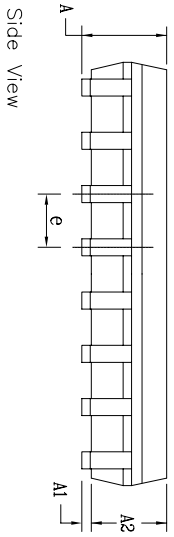

Side View

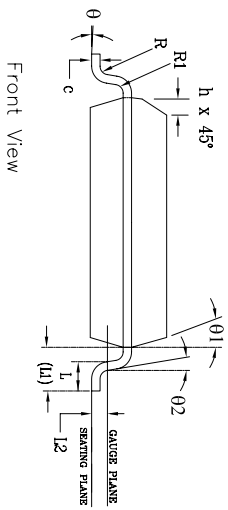

Front View

28 Pin SOICW		JEDEC MS-013		Variation AE	
SYMBOLS	DIMENSIONS IN MM (Control Unit)		DIMENSIONS IN INCH (Reference Unit)		MAX
	MIN	NOM	MIN	NOM	
A	2.35	—	2.65	0.093	—
A1	0.10	—	0.30	0.004	—
A2	2.05	—	2.55	0.081	—
b	0.31	—	0.51	0.012	—
c	0.20	—	0.33	0.008	—
E	10.30	BSC	—	—	0.406 BSC
E1	7.50	BSC	—	—	0.295 BSC
e	1.27	BSC	—	—	0.050 BSC
h	0.25	—	0.75	0.010	—
L	0.40	—	1.27	0.016	—
L1	1.40	REF	—	—	0.055 REF
L2	—	0.25 BSC	—	—	0.010 BSC
R	0.07	—	—	—	0.003
R1	0.07	—	—	0.003	—
θ	0°	—	8°	0°	—
01	5°	—	15°	5°	—
02	0°	—	—	0°	—
D	—	17.90 BSC	—	—	0.705 BSC
N	—	28	—	—	28

		EXAR CORPORATION			
				28 PIN SOICW PACKAGE OUTLINE	
Packaging Approver:	By: JL	Date: 11/28/07	Drawing No: 28-PIN SOICW	Revision: B	Sheet: 1 OF 1

ORDERING INFORMATION

Model	Temperature Range	Package Types
SP331CT-L.....	0°C to +70°C.....	28-pin WSOIC
SP331CT-L/TR.....	0°C to +70°C.....	28-pin WSOIC
SP331ET-L.....	-40°C to +85°C.....	28-pin WSOIC
SP331ET-L/TR.....	-40°C to +85°C.....	28-pin WSOIC

Note: /TR = Tape and Reel

REVISION HISTORY

DATE	REVISION	DESCRIPTION
01-04-05	-	Legacy Sipex Datasheet
01/26/10	1.0.0	Convert to Exar Format. Add Revision History table. Change revision to 1.0.0. Add Note 1 and change maximum RS-485 data rate at +85C. Update ABS Max Rating table.

Notice

EXAR Corporation reserves the right to make changes to any products contained in this publication in order to improve design, performance or reliability. EXAR Corporation assumes no representation that the circuits are free of patent infringement. Charts and schedules contained herein are only for illustration purposes and may vary depending upon a user's specific application. While the information in this publication has been carefully checked; no responsibility, however, is assumed for inaccuracies.

EXAR Corporation does not recommend the use of any of its products in life support applications where the failure or malfunction of the product can reasonably be expected to cause failure of the life support system or to significantly affect its safety or effectiveness. Products are not authorized for use in such applications unless EXAR Corporation receives, in writing, assurances to its satisfaction that: (a) the risk of injury or damage has been minimized ; (b) the user assumes all such risks; (c) potential liability of EXAR Corporation is adequately protected under the circumstances.

Copyright 2010 EXAR Corporation

Datasheet January 2010

Send your Interface technical inquiry with technical details to: uarttechsupport@exar.com

Reproduction, in part or whole, without the prior written consent of EXAR Corporation is prohibited.

www.BDTIC.com/Exar/