

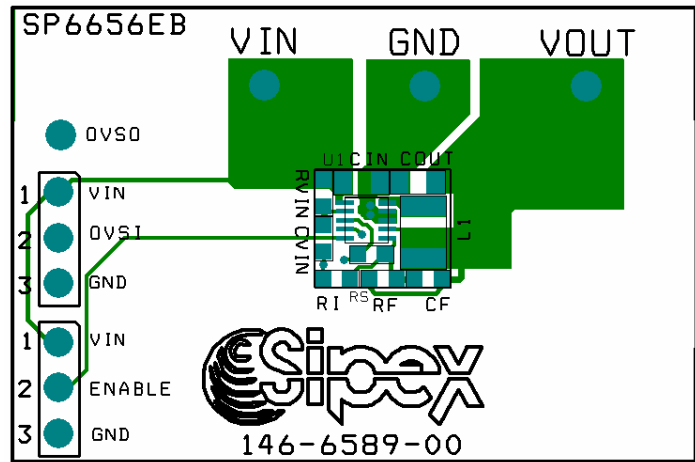

# SP6656EB Evaluation Board Manual

- High Efficiency Synchronous Step-Down Converter with up to 98% efficiency
- 400mA Output Current, only 20uA Quiescent Current
- 2.9V-5.5V Input Voltage range, Output Adjustable down to 1.0V
- Small 2.5x2.4mm DFN Package & Ceramic Capacitors for small, low profile Power Supply
- Ideal for PDAs, Digital Cameras, Wireless Modems, Cellular Telephones



## DESCRIPTION

The **SP6656 Evaluation Board** is designed to help the user evaluate the performance of the SP6656 for use as a single Li-Ion battery Step-Down DC-DC Converter. The SP6656 operates from 2.7V to 6.5V input, with the highest efficiency in the range 3.0V to 4.2V where the Li-Ion battery has the most energy. The SP6656EB evaluation board is a complete power supply circuit to provide ease of evaluation for the DC/DC Converter performance.

**FIGURE 1. SP6656 1.8V OUTPUT EVALUATION BOARD SCHEMATIC**

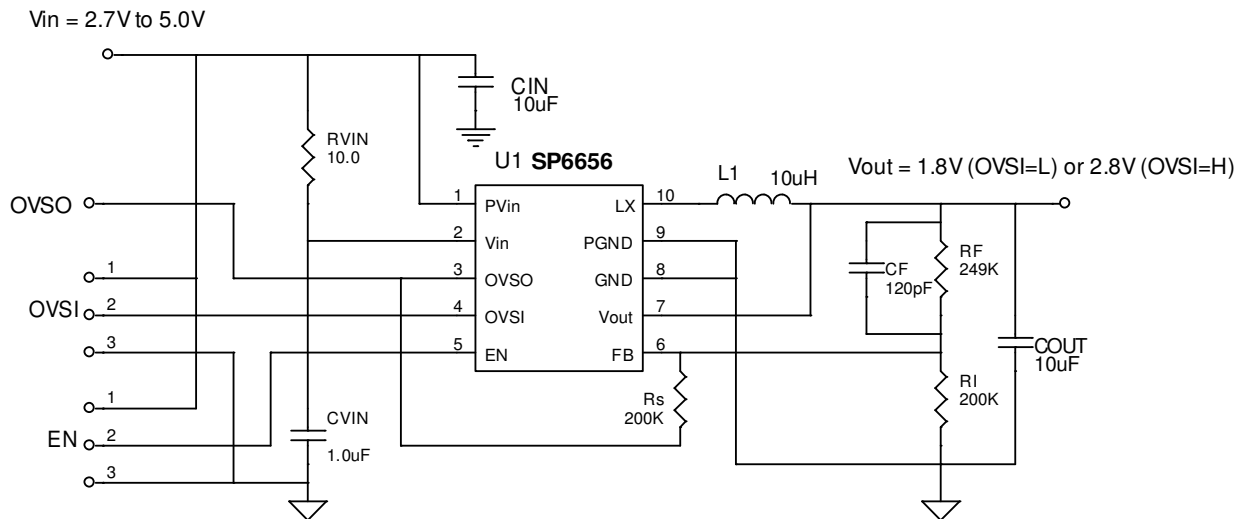

## USING THE EVALUATION BOARD

## 1) Powering up the SP6656 Circuit

The SP6656 Evaluation Board can be powered from a single Li-Ion battery or a +2.7 to +5.0V power supply. Connect with short leads directly to the “Vin” and “Gnd” posts. Note the SP6656 will remain in “shutdown” until the EN Jumper J1 is applied to the Vin or position 1 to 2.

## 2) VOUT PROGRAMMING

The SP6656 has a dynamically programmable output voltage using the OVSI and OVSO pins. This requires 2 feedback resistors to control the output voltage as well as an RS resistor for the dynamically programmed output voltage. Connect the appropriate resistors RF and RI (Table 1) from pin 6 SP6656 FB to Vout and to the GND.

For Vout Low, select OVSI = L and use the formula below to set the output voltage:

$$RF = \left( \frac{V_{out}}{0.8} - 1 \right) \cdot RI$$

For Vout High, select OVSI = H, and the RS resistor will be switched in to change the output voltage from the previously set voltage to a larger output voltage, determined by the following equation:

$$RF = \left( \frac{V_{out}}{0.8} - 1 \right) \cdot RA$$

where  $RA = \frac{RI * RS}{RI + RS}$

**Table 1. SP6656EB BILL OF MATERIALS**

Component	Vo = 1.8V
L1	10uH, Murata LQH32CN100K11, 0.3ohm, 0.45A, 1210
CIN	10uF, TDK C2012X5R0J106M, 0.005ohm, 6.3V, X5R, 0805
COU1	10uF, TDK C2012X5R0J106M, 0.005ohm, 6.3V, X5R, 0805
RVIN	10 Ohm 5%, 0603
CVIN	1uF, TDK C1608X5R0J105M, 0.03ohm, .3V, X5R, 0603
RI	200k 1%, 0603
RF	249k 1%, 0603
RF	200k 1%, 0603
CF	22pF ceramic, 0603

**Table 3. SP6656 PIN ASSIGNMENT**

<b>Pin Name</b>	<b>Pin Description</b>	<b>Pin NO.</b>
<b>PVin</b>	Input voltage power pin. Inductor charging current passes through this pin.	<b>1</b>
<b>Vin</b>	Internal supply voltage. Control circuitry powered from this pin.	<b>2</b>
<b>OVSO</b>	Output Voltage Select Open Drain Output .	<b>3</b>
<b>OVSI</b>	Output Voltage Select digital input.	<b>4</b>
<b>EN</b>	Enable digital input.	<b>5</b>
<b>FB</b>	External feedback network input connection. Connect a resistor from FB to ground and FB to Vout to control the output voltage. This pin regulates to the internal reference voltage of 0.8V.	<b>6</b>
<b>Vout</b>	Output voltage sense pin. Used for internal timing circuitry.	<b>7</b>
<b>GND</b>	Internal ground pin. Control circuitry returns current to this pin.	<b>8</b>
<b>PGND</b>	Power ground pin. Synchronous rectifier current returns through this pin.	<b>9</b>
<b>LX</b>	Inductor switching node. Inductor tied between this pin and the output capacitor to create Vout.	<b>10</b>

## EVALUATION BOARD LAYOUT

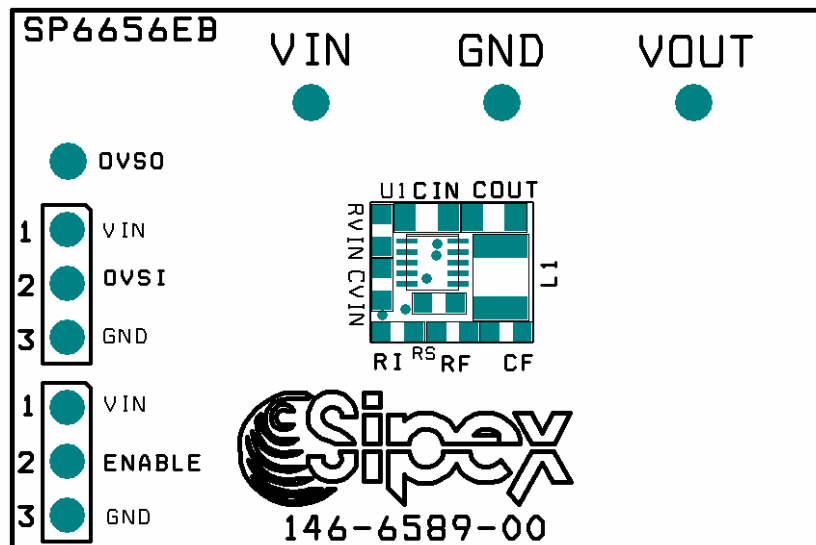

FIGURE 3: SP6656EB COMPONENT PLACEMENT

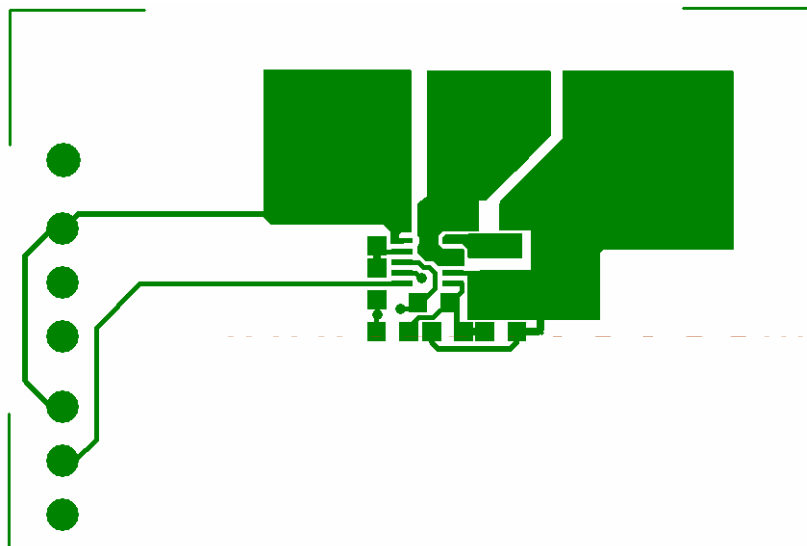

FIGURE 4: SP6656EB PC LAYOUT TOP SIDE

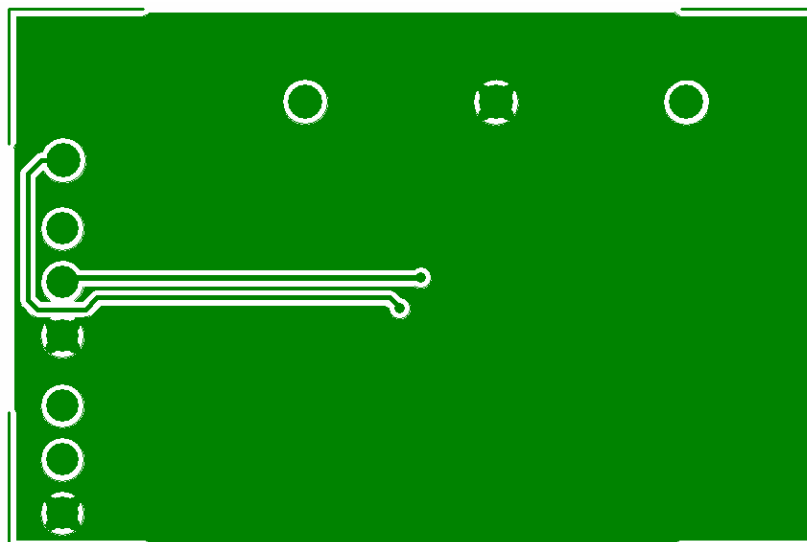

FIGURE 5: SP6656EB PC LAYOUT BOTTOM SIDE