

MA4EX950L1-1225T



Silicon Double Balanced HMIC Mixer
700 - 1200 MHz

Rev. V2

Features

- SOT-25 Low Cost Miniature Plastic Package
- 6.5 dB Typical Conversion Loss
- +3 to +7 dBm LO Drive
- HMIC™ Patented Process
- Silicon Low Barrier Schottky Barrier Diodes
- DC - 400 MHz IF Bandwidth
- RoHS* Compliant with 260°C Reflow Capability
- 100 % Matte Tin Plating

Description and Applications

M/A-COM's MA4EX950L1-1225T is a 700-1200 MHz silicon monolithic double balanced mixer in a low cost miniature surface mount SOT-25 package. The die uses M/A-COM's unique HMIC silicon/glass process to realize low loss passive elements while retaining the advantages of medium barrier silicon Schottky barrier diodes.

These mixers are well suited for high volume wireless and cellular applications where small size and repeatability are required. Typical applications include frequency conversion, modulation, and demodulation in wireless receivers and transmitters.

Ordering Information

Part Number	Package
MA4EX950L1-1225T	Tape and Reel

SOT-25 Package Outline (Topview)

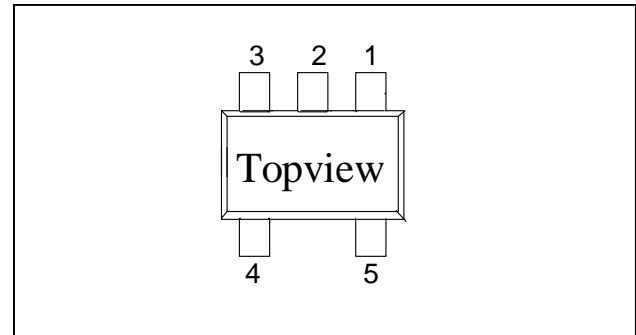

PIN Configuration

PIN	Function	PIN	Function
1	RF	4	GND
2	GND	5	IF
3	LO	-	-

* Restrictions on Hazardous Substances, European Union Directive 2005/95/EC.

1

ADVANCED: Data Sheets contain information regarding a product M/A-COM Technology Solutions is considering for development. Performance is based on target specifications, simulated results, and/or prototype measurements. Commitment to develop is not guaranteed.

PRELIMINARY: Data Sheets contain information regarding a product M/A-COM Technology Solutions has under development. Performance is based on engineering tests. Specifications are typical. Mechanical outline has been fixed. Engineering samples and/or test data may be available. Commitment to produce in volume is not guaranteed.

• **North America** Tel: 800.366.2266 / Fax: 978.366.2266

• **Europe** Tel: 44.1908.574.200 / Fax: 44.1908.574.300

• **Asia/Pacific** Tel: 81.44.844.8296 / Fax: 81.44.844.8298

Visit www.macomtech.com for additional data sheets and product information.

M/A-COM Technology Solutions Inc. and its affiliates reserve the right to make changes to the product(s) or information contained herein without notice.

MA4EX950L1-1225T



Silicon Double Balanced HMIC Mixer
700 - 1200 MHz

Rev. V2

Electrical Specifications @ +25 °C

Parameter	Frequency Range	Test Conditions	Units	Min.	Typ.	Max.
Conversion Loss	850 MHz 0.7—1.2 GHz	LO Drive = +3 -> + 7dBm RF = -10 dBm, IF = 60 MHz	dB		7.0 8.0	7.5 10.5
L - R Isolation	850 MHz 0.7—1.2 GHz	LO Drive = +5 dBm RF Level = -10 dBm	dB		28.0 25.0	
L - I Isolation	850 MHz 0.7—1.2 GHz	LO Drive = +5 dBm RF Level = -10 dBm	dB		27.0 26.0	
R - I Isolation	850 MHz 0.7—1.2 GHz	LO Drive = +5 dBm RF Level = -10 dBm	dB		28.0 24.0	
LO VSWR	850 MHz 0.7—1.2 GHz	LO Drive = +5 dBm RF Level = -10 dBm			2.4:1 2.8:1	- -
RF VSWR	850 MHz 0.7—1.2 GHz	LO Drive = +15 dBm RF Level = -10 dBm			1.3:1 2.7:1	- -
IF VSWR	DC - 400 MHz	LO Drive = +5 dBm RF Level = -10 dBm			1.4:1	-
Input IP3	850 MHz 0.7—1.2 GHz	LO Drive = +3 -> + 7dBm RF = -10 dBm, IF = 60 MHz	dBm	11.0 9.0	13.2 14.0	
Input 1 dB Compression	850 MHz 0.7—1.2 GHz	LO Drive = +3 -> + 7dBm RF = -10 dBm, IF = 60 MHz	dBm		0 +1.5	
IF 1 dB Bandwidth	DC - 400 MHz	LO = 4650 MHz @ +5 dBm	MHz	0		400.0

ADVANCED: Data Sheets contain information regarding a product M/A-COM Technology Solutions is considering for development. Performance is based on target specifications, simulated results, and/or prototype measurements. Commitment to develop is not guaranteed.

PRELIMINARY: Data Sheets contain information regarding a product M/A-COM Technology Solutions has under development. Performance is based on engineering tests. Specifications are typical. Mechanical outline has been fixed. Engineering samples and/or test data may be available. Commitment to produce in volume is not guaranteed.

- **North America** Tel: 800.366.2266 / Fax: 978.366.2266
- **Europe** Tel: 44.1908.574.200 / Fax: 44.1908.574.300
- **Asia/Pacific** Tel: 81.44.844.8296 / Fax: 81.44.844.8298

Visit www.macomtech.com for additional data sheets and product information.

M/A-COM Technology Solutions Inc. and its affiliates reserve the right to make changes to the product(s) or information contained herein without notice.

Typical Performance Curves (LO Drive = +10 dBm, RF = -10 dBm, IF = 60 MHz)

Conversion Loss

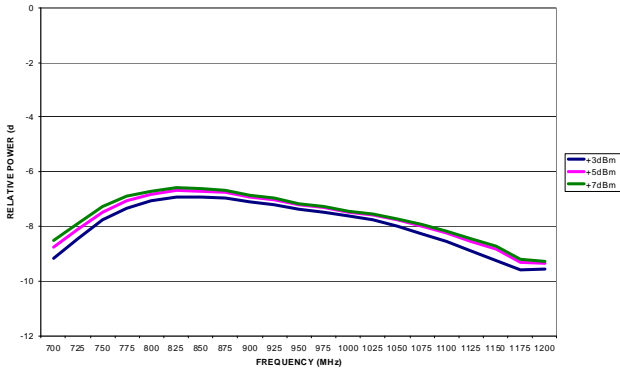

Isolation

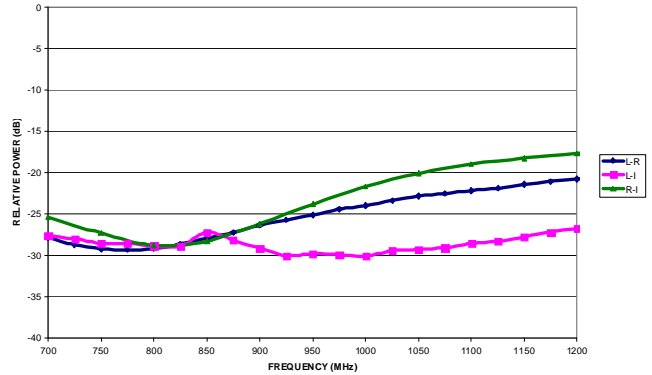

Typical LO, RF and IF VSWR

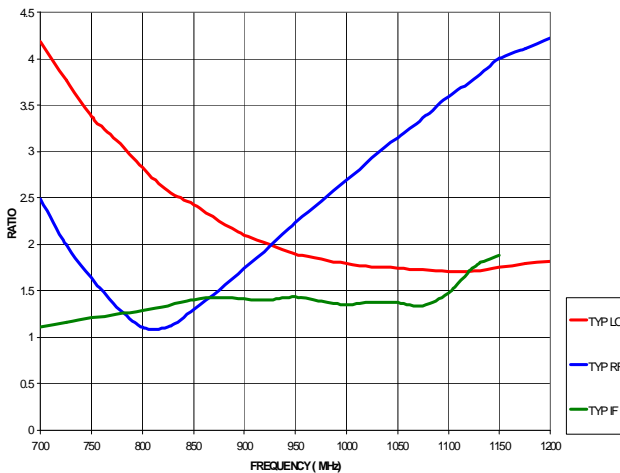

Third Order Intercept and Input 1 dB Compression Power

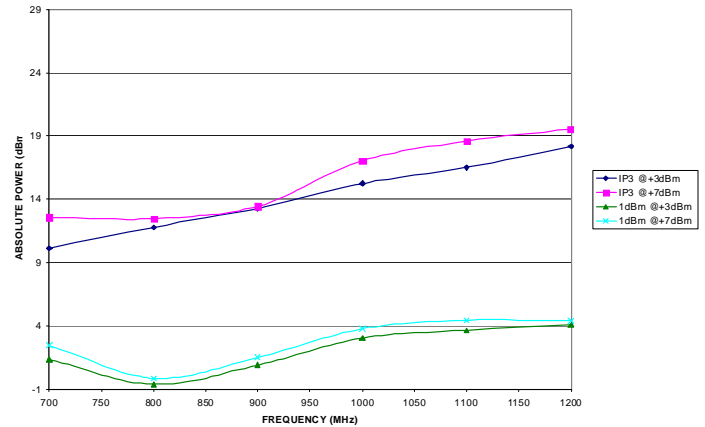

MA4EX950L1-1225T



Silicon Double Balanced HMIC Mixer
700 - 1200 MHz

Rev. V2

Case Style SOT-25

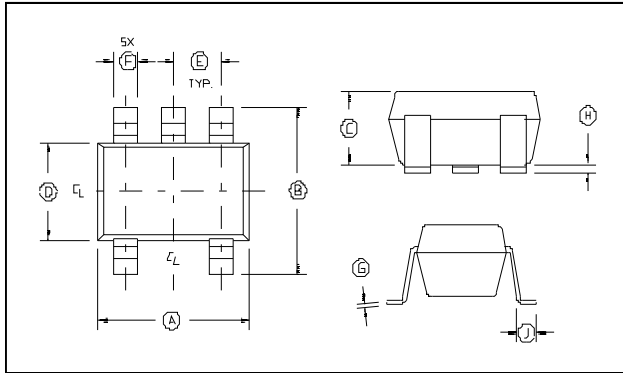

SOT-25^{3,4}

Dim	Inches		Millimeters	
	Min.	Max.	Min.	Max.
A	.1103	.1181	2.80	3.10
B	.1023	.1181	2.6	3.00
C	0.0355	.0512	0.9	1.30
D	0.0591	0.669	1.5	1.70
E	.0374 REF.		.095 REF.	
F	.0138	.0197	.35	.50
G	.0031	0.0079	.08	0.2
H	.0002	.0059	.05	.15
J	0.138	0.216	.35	.55

- Dimensions do not include mold flash, protrusion or gate burrs which shall not exceed 0.0098 in (.25mm) per side.
- Lead Coplanarity is 0.003 (0.08) max.

Absolute Maximum Ratings^{1,2}

Parameter	Maximum Ratings
Operating Temperature	-65 °C to +125 °C
Storage Temperature	-65 °C to +150 °C
Incident LO Power	+20 dBm
Incident RF Power	+20 dBm
Mounting Temperature	+235 °C for 10 seconds
Soldering Temperature	+260 °C max.

- Exceeding these limits may cause permanent damage.
- Please refer to application note M538 for surface mounting instructions.

Schematic

