

# MA4SW410

## HMIC™ Silicon SP4T PIN Diode Switch RoHS Compliant

Rev. 3

### Features

- ◆ Ultra Broad Bandwidth: 50MHz to 26GHz
- ◆ 0.9 Insertion Loss , 34dB Isolation at 20GHz
- ◆ 50nS Switching Speed
- ◆ Fully Monolithic, Glass Encapsulated Chip with Polymer Protective Coating

### Description

The MA4SW410 is a SP4T series-shunt broad band switch made with M/A-COM's unique HMIC™ (Heterolithic Microwave Integrated Circuit) process, US Patent 5,268,310. This process allows the incorporation of silicon pedestals that form series and shunt diodes or vias by imbedding them in a low loss, low dispersion glass. This hybrid combination of silicon and glass gives HMIC switches exceptional low loss and remarkable high isolation through low millimeter-wave frequencies.

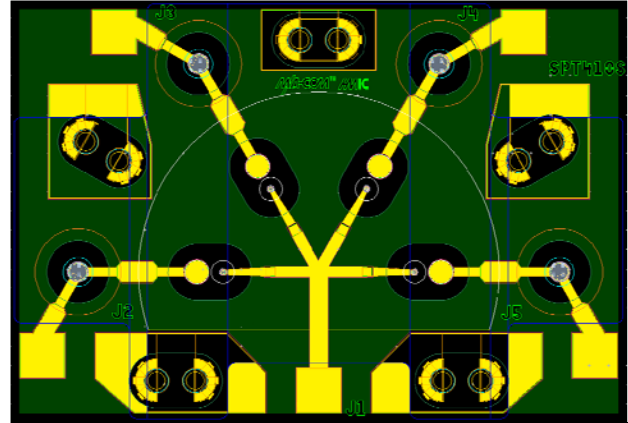

### Applications

These high performance switches are suitable for use in multi-band ECM, radar, and instrumentation control circuits where high isolation to insertion loss ratios are required. With a standard +5V/-5V, TTL controlled PIN diode driver, 50nS switching speeds are achieved.

### Absolute Maximum Ratings

T<sub>AMB</sub> = +25°C ( Unless Otherwise Specified )

Parameter	Value
Operating Temperature	-65°C to +125°C
Storage Temperature	-65°C to +150°C
RF C.W. Incident Power	+30dBm
Forward Bias Current	± 20mA
Reverse Applied Voltage	-25 Volts

### Notes:

1. Exceeding any one of these values may result in permanent damage to the chip.
2. Maximum operating conditions for combination of RF power, D.C. bias and temperature:  
+30dBm C.W. @ 15mA/diode @ +85°C

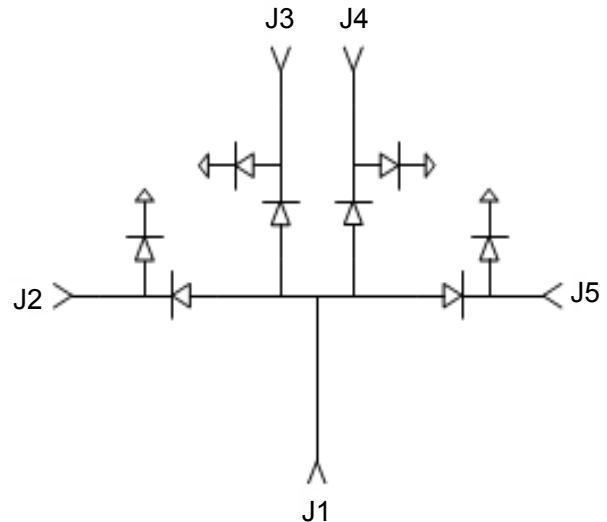

**ADVANCED:** Data Sheets contain information regarding a product M/A-COM is considering for development. Performance is based on target specifications, simulated results, and/or prototype measurements. Commitment to develop is not guaranteed.

**PRELIMINARY:** Data Sheets contain information regarding a product M/A-COM has under development. Performance is based on engineering tests. Specifications are typical. Mechanical outline has been fixed. Engineering samples and/or test data may be available. Commitment to produce in volume is not guaranteed.

- **North America** Tel: 800.366.2266 / Fax: 978.366.2266
- **Europe** Tel: 44.1908.574.200 / Fax: 44.1908.574.300
- **Asia/Pacific** Tel: 81.44.844.8296 / Fax: 81.44.844.8298

Visit [www.macom.com](http://www.macom.com) for additional data sheets and product information.

M/A-COM Inc. and its affiliates reserve the right to make changes to the product(s) or information contained herein without notice.

# MA4SW410

**HMIC™ Silicon SP4T PIN Diode Switch**  
**RoHS Compliant**

Rev. 3

## Typical Driver Connections

Control Level ( DC Current ) at Port				Condition of RF Output	Condition of RF Output	Condition of RF Output	Condition of RF Output
J2	J3	J4	J5	J1 - J2	J1 - J3	J1 - J4	J1 - J5
-20mA	+20mA	+20mA	+20mA	<b>Low Loss</b>	Isolation	Isolation	Isolation
+20mA	-20mA	+20mA	+20mA	Isolation	<b>Low Loss</b>	Isolation	Isolation
+20mA	+20mA	-20mA	+20mA	Isolation	Isolation	<b>Low Loss</b>	Isolation
+20mA	+20mA	+20mA	-20mA	Isolation	Isolation	Isolation	<b>Low Loss</b>

## Electrical Specifications @ T<sub>AMB</sub> = +25°C, ± 20mA Bias Current (On-Wafer Measurements)

Parameter	Frequency	Minimum	Nominal	Maximum	Units
Insertion Loss	20 GHz		0.9	1.3	dB
Isolation	20 GHz	28	34		dB
Input Return Loss	20 GHz		15		dB
Output Return Loss	20 GHz		15		dB
Switching Speed <sup>1</sup>	10 GHz		50		nS

### Note:

1. Typical switching speed is measured from 10% to 90% of detected RF voltage driven by a TTL compatible driver. Driver output parallel RC network uses a capacitor between 390pF – 560pF and a resistor between 150Ω – 220Ω to achieve 50nS rise and fall times.

**ADVANCED:** Data Sheets contain information regarding a product M/A-COM is considering for development. Performance is based on target specifications, simulated results, and/or prototype measurements. Commitment to develop is not guaranteed.

**PRELIMINARY:** Data Sheets contain information regarding a product M/A-COM has under development. Performance is based on engineering tests. Specifications are typical. Mechanical outline has been fixed. Engineering samples and/or test data may be available. Commitment to produce in volume is not guaranteed.

- **North America** Tel: 800.366.2266 / Fax: 978.366.2266
- **Europe** Tel: 44.1908.574.200 / Fax: 44.1908.574.300
- **Asia/Pacific** Tel: 81.44.844.8296 / Fax: 81.44.844.8298

Visit [www.macom.com](http://www.macom.com) for additional data sheets and product information.

M/A-COM Inc. and its affiliates reserve the right to make changes to the product(s) or information contained herein without notice.

# MA4SW410

HMIC™ Silicon SP4T PIN Diode Switch  
RoHS Compliant

Rev. 3

## Operation of the MA4SW410 PIN Switch

Operation of the MA4SW410 PIN switch is achieved by the simultaneous application of negative DC current to the low loss port and positive DC current to the remaining isolated switching ports as shown in Figure 1. The backside area of the die is the RF and DC return ground plane. The DC return is achieved on the common port, J1. The DC control currents should be supplied by constant current source. The voltages at these points will not exceed  $\pm 1.5$  volts (1.2 volts typical) for supply currents up to  $\pm 20$ mA. In the low loss state, the series diode must be forward biased and the shunt diode reverse biased. For all the isolated ports, the shunt diode is forward biased and the series diode is reverse biased. The bias network design should yield  $> 30$ dB RF to DC isolation.

Best insertion loss, P1dB, IP3, and switching speed are achieved by using a voltage pull-up resistor in the DC return path, J1. A minimum value of  $|-2V|$  is recommended at this return node, which is achievable with a standard,  $\pm 5V$  TTL controlled PIN driver. A typical DC bias schematic for 2-18 GHz operation is shown in Fig.1.

## 2 – 18 GHz Bias Network Schematic

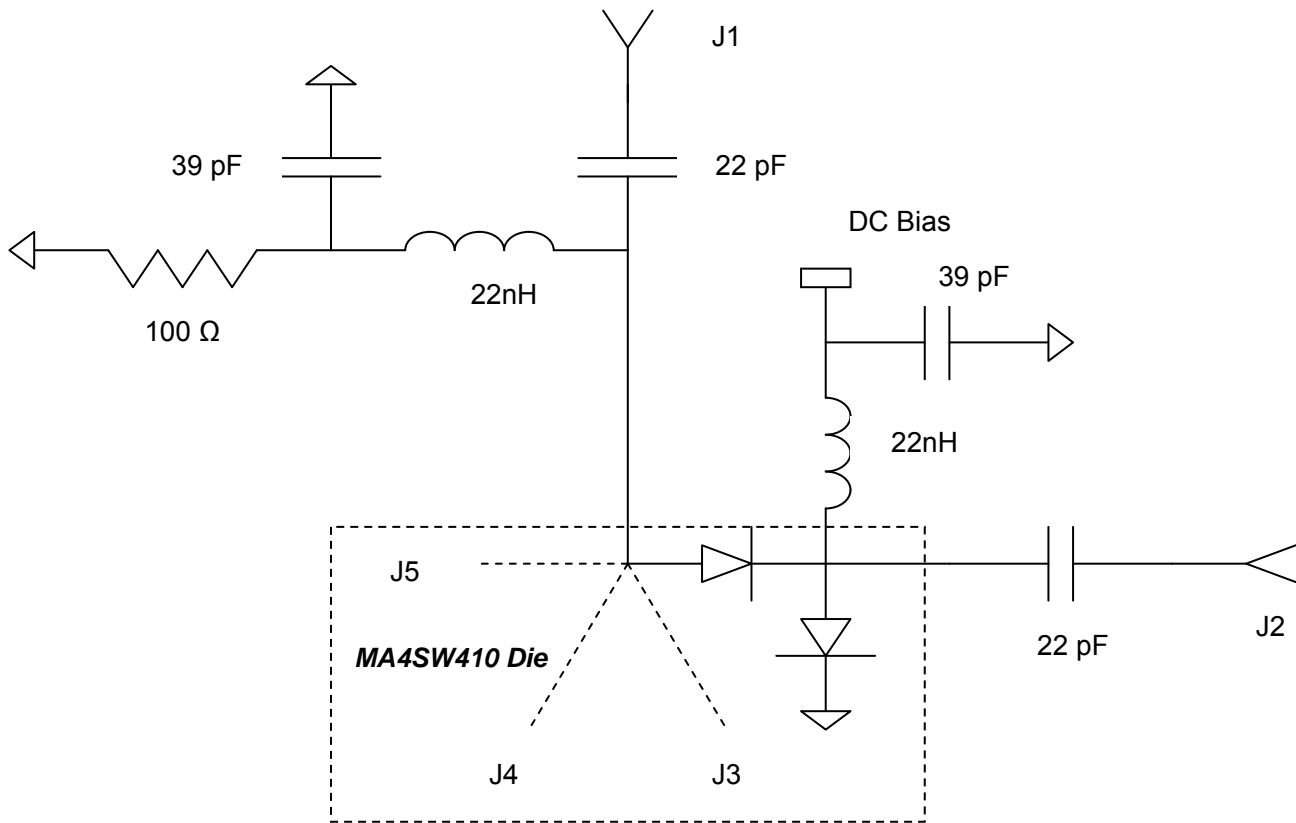

Fig. 1

**ADVANCED:** Data Sheets contain information regarding a product M/A-COM is considering for development. Performance is based on target specifications, simulated results, and/or prototype measurements. Commitment to develop is not guaranteed.

**PRELIMINARY:** Data Sheets contain information regarding a product M/A-COM has under development. Performance is based on engineering tests. Specifications are typical. Mechanical outline has been fixed. Engineering samples and/or test data may be available. Commitment to produce in volume is not guaranteed.

- **North America** Tel: 800.366.2266 / Fax: 978.366.2266
- **Europe** Tel: 44.1908.574.200 / Fax: 44.1908.574.300
- **Asia/Pacific** Tel: 81.44.844.8296 / Fax: 81.44.844.8298

Visit [www.macom.com](http://www.macom.com) for additional data sheets and product information.

M/A-COM Inc. and its affiliates reserve the right to make changes to the product(s) or information contained herein without notice.

# MA4SW410

HMIC™ Silicon SP4T PIN Diode Switch  
RoHS Compliant

Rev. 3

## Typical Microwave Performance

### MA4SW410 INSERTION LOSS

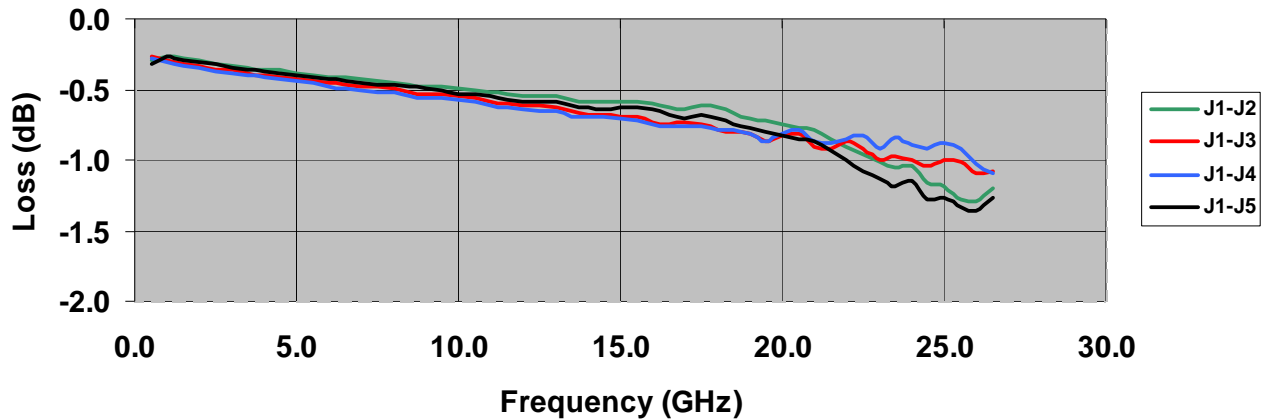

### MA4SW410 INPUT RETURN LOSS

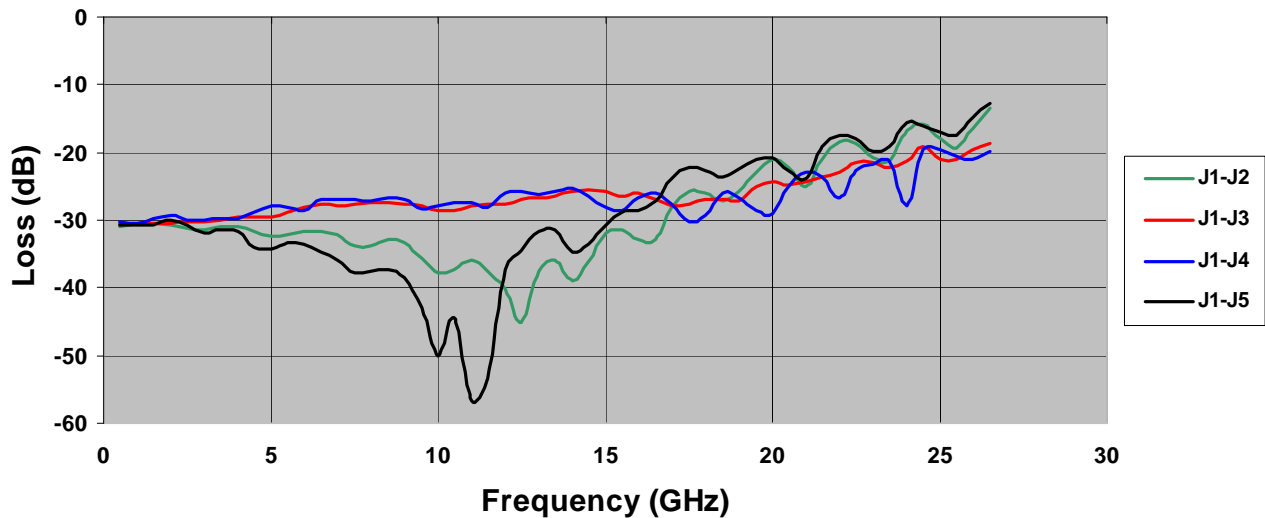

**ADVANCED:** Data Sheets contain information regarding a product M/A-COM is considering for development. Performance is based on target specifications, simulated results, and/or prototype measurements. Commitment to develop is not guaranteed.

**PRELIMINARY:** Data Sheets contain information regarding a product M/A-COM has under development. Performance is based on engineering tests. Specifications are typical. Mechanical outline has been fixed. Engineering samples and/or test data may be available. Commitment to produce in volume is not guaranteed.

- **North America** Tel: 800.366.2266 / Fax: 978.366.2266
- **Europe** Tel: 44.1908.574.200 / Fax: 44.1908.574.300
- **Asia/Pacific** Tel: 81.44.844.8296 / Fax: 81.44.844.8298

Visit [www.macom.com](http://www.macom.com) for additional data sheets and product information.

M/A-COM Inc. and its affiliates reserve the right to make changes to the product(s) or information contained herein without notice.

# MA4SW410

HMIC™ Silicon SP4T PIN Diode Switch  
RoHS Compliant

Rev. 3

## Typical Microwave Performance

### MA4SW410 OUTPUT RETURN LOSS

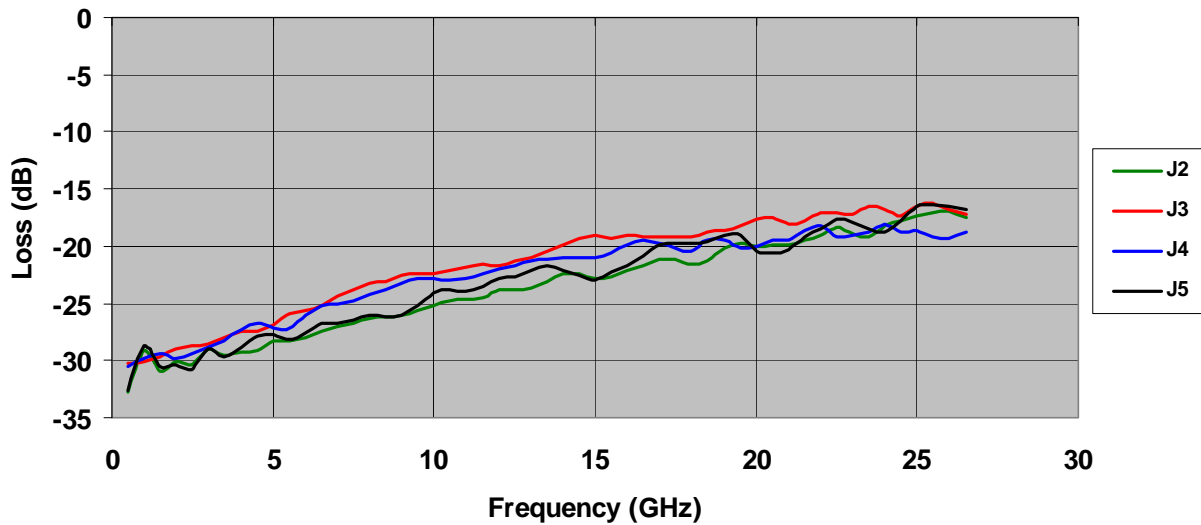

### MA4SW410 ISOLATION

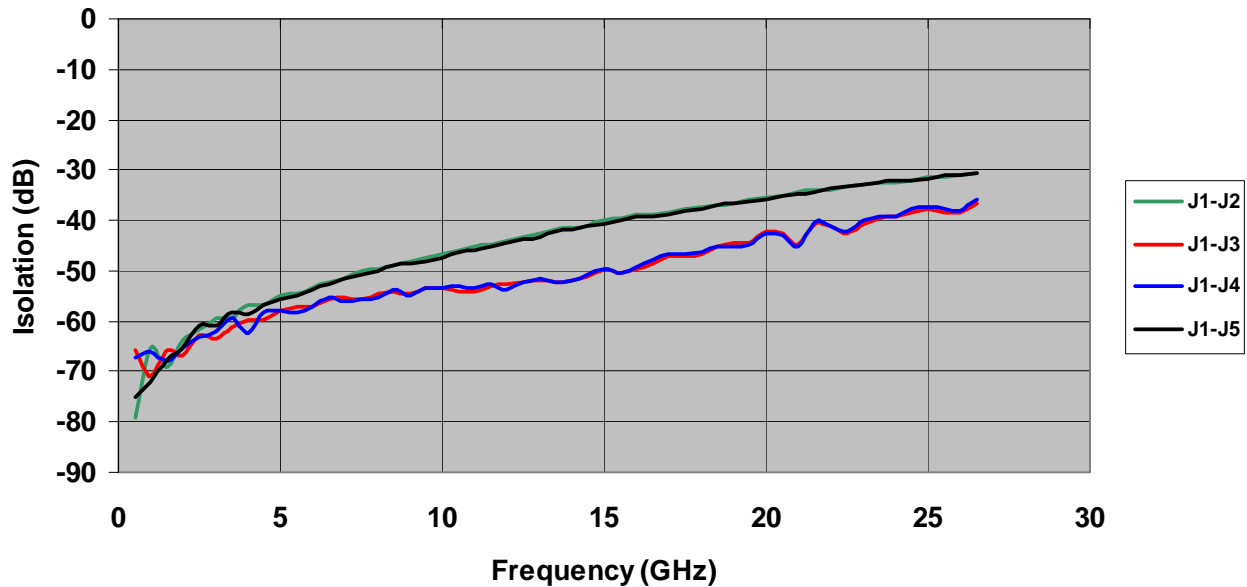

**ADVANCED:** Data Sheets contain information regarding a product M/A-COM is considering for development. Performance is based on target specifications, simulated results, and/or prototype measurements. Commitment to develop is not guaranteed.

**PRELIMINARY:** Data Sheets contain information regarding a product M/A-COM has under development. Performance is based on engineering tests. Specifications are typical. Mechanical outline has been fixed. Engineering samples and/or test data may be available. Commitment to produce in volume is not guaranteed.

- **North America** Tel: 800.366.2266 / Fax: 978.366.2266
- **Europe** Tel: 44.1908.574.200 / Fax: 44.1908.574.300
- **Asia/Pacific** Tel: 81.44.844.8296 / Fax: 81.44.844.8298

Visit [www.macom.com](http://www.macom.com) for additional data sheets and product information.

M/A-COM Inc. and its affiliates reserve the right to make changes to the product(s) or information contained herein without notice.

## MA4SW410

HMIC™ Silicon SP4T PIN Diode Switch  
RoHS Compliant

Rev. 3

### ASSEMBLY INSTRUCTIONS

#### Cleanliness

These chips should be handled in a clean environment free of organic contamination.

#### Electro-Static Sensitivity

The MA4SW410 PIN diode switch is ESD, Class 1A sensitive (HBM). The proper ESD handling procedures must be used.

#### Wire Bonding

Thermosonic wedge bonding using 0.003" x 0.00025" ribbon or 0.001" diameter gold wire is recommended. A heat stage temperature of 150°C and a force of 18 to 22 grams should be used. If ultrasonic energy is necessary, it should be adjusted to the minimum level required to achieve a good bond. RF bond wires should be kept as short as possible.

#### Chip Mounting

The HMIC switches have Ti-Pt-Au back metal. They can be die mounted with a gold-tin eutectic solder preform or conductive epoxy. Mounting surface must be clean and flat.

**Eutectic Die Attachment:** An 80/20, gold-tin, eutectic solder preform is recommended with a work surface temperature of 255°C and a tool tip temperature of 265°C. When hot gas is applied, the temperature at the chip should be 290°C. The chip should not be exposed to temperatures greater than 320°C for more than 20 seconds. No more than three seconds should be required for attachment. Solders rich in tin should not be used.

**Epoxy Die Attachment:** A minimum amount of epoxy, 1-2 mils thick, should be used to attach chip. A thin epoxy fillet should be visible around the outer perimeter of the chip after placement. Cure epoxy per product instructions. Typically 150°C for 1 hour.

**ADVANCED:** Data Sheets contain information regarding a product M/A-COM is considering for development. Performance is based on target specifications, simulated results, and/or prototype measurements. Commitment to develop is not guaranteed.

**PRELIMINARY:** Data Sheets contain information regarding a product M/A-COM has under development. Performance is based on engineering tests. Specifications are typical. Mechanical outline has been fixed. Engineering samples and/or test data may be available. Commitment to produce in volume is not guaranteed.

- **North America** Tel: 800.366.2266 / Fax: 978.366.2266
- **Europe** Tel: 44.1908.574.200 / Fax: 44.1908.574.300
- **Asia/Pacific** Tel: 81.44.844.8296 / Fax: 81.44.844.8298

Visit [www.macom.com](http://www.macom.com) for additional data sheets and product information.

*M/A-COM Inc. and its affiliates reserve the right to make changes to the product(s) or information contained herein without notice.*

# MA4SW410

HMIC™ Silicon SP4T PIN Diode Switch  
RoHS Compliant

Rev. 3

## MA4SW410 Chip Dimensions

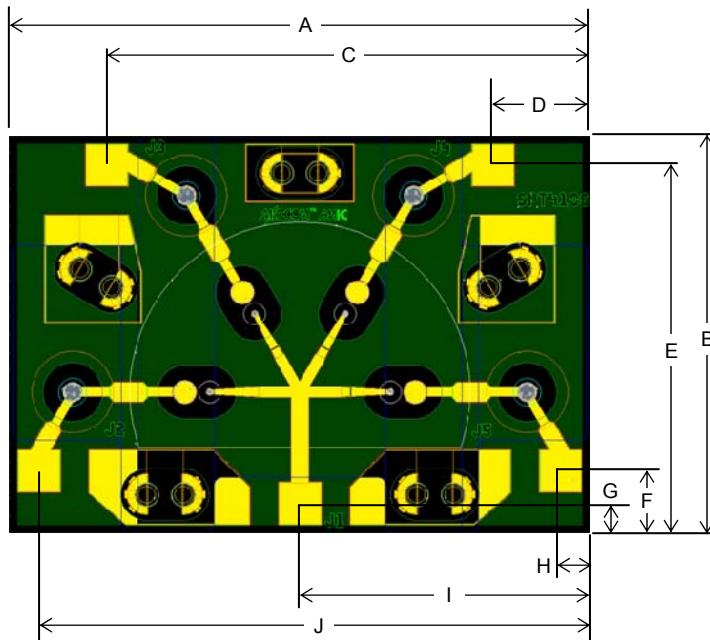

### Notes:

1. Topside and backside metallization is gold, 2.5mm thick

DIM	INCHES	MM
	NOMINAL	NOMINAL
A	.066	1.67
B	.047	1.19
C	.054	1.37
D	.012	0.31
E	.043	1.08
F	.009	0.22
G	.004	0.11
H	.004	0.11
I	.033	0.84
J	.061	1.56
Thickness	.005	.120
Bond Pads	.005X.005	0.120X.0120

All tolerances are  $\pm .0005$  inches

**ADVANCED:** Data Sheets contain information regarding a product M/A-COM is considering for development. Performance is based on target specifications, simulated results, and/or prototype measurements. Commitment to develop is not guaranteed.

**PRELIMINARY:** Data Sheets contain information regarding a product M/A-COM has under development. Performance is based on engineering tests. Specifications are typical. Mechanical outline has been fixed. Engineering samples and/or test data may be available. Commitment to produce in volume is not guaranteed.

- **North America** Tel: 800.366.2266 / Fax: 978.366.2266
- **Europe** Tel: 44.1908.574.200 / Fax: 44.1908.574.300
- **Asia/Pacific** Tel: 81.44.844.8296 / Fax: 81.44.844.8298

Visit [www.macom.com](http://www.macom.com) for additional data sheets and product information.

M/A-COM Inc. and its affiliates reserve the right to make changes to the product(s) or information contained herein without notice.