

## Cascadable Amplifier 10 to 1200 MHz

Rev. V4

### Features

- LOW NOISE: 3.5 dB (TYP.)
- HIGH EFFICIENCY: 15 mA (TYP.) @ +5 Volts
- GOOD DYNAMIC RANGE: 102.5 dB (TYP.) in 1 MHz BW
- LOW VSWR: <1.5:1 (TYP.)

### Description

The A16-2 RF amplifier is a discrete thin film hybrid design, which incorporates the use of thin film manufacturing processes for accurate performance and high reliability.

This single stage bipolar transistor feedback amplifier design displays impressive performance over a broadband frequency range. An active DC biasing network is used for temperature-stable performance, in addition to an RF Choke, used for power supply decoupling.

Both TO-8 and Surface Mount packages are hermetically sealed, and MIL-STD-883 environmental screening is available.

### Ordering Information

Part Number	Package
MAAM-008198-00A162	TO-8
MAAM-008198-SMA162	Surface Mount
MAAM-008198-OCA162	SMA Connectorized **

\*\* The connectorized version is not RoHs compliant.

### Product Image

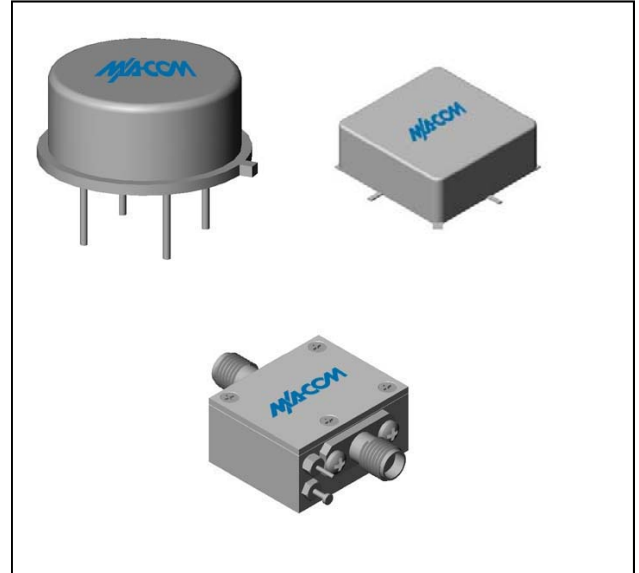

### Electrical Specifications: $Z_0 = 50\Omega$ , $V_{CC} = +5 V_{DC}$

Parameter	Units	Typical	Guaranteed	
		25°C	0° to 50°C	-54° to +85°C*
Frequency	MHz	5-1300	10-1200	10-1200
Small Signal Gain (min)	dB	13.0	12.0	11.5
Gain Flatness (max)	dB	±0.2	±0.5	±0.7
Reverse Isolation	dB	16		
Noise Figure (max)	dB	3.5	4.0	4.5
Power Output @ 1 dB comp. (min)	dBm	6.0	5.0	4.5
IP3	dBm	+18		
IP2	dBm	+28		
Second Order Harmonic IP	dBm	+34		
VSWR Input / Output (max)		1.5:1 / 1.5:1	2.2:1 / 2.2:1	2.3:1 / 2.3:1
DC Current @ 15 Volts (max)	mA	15	17	18

### Absolute Maximum Ratings

Parameter	Absolute Maximum
Storage Temperature	-62°C to +125°C
Case Temperature	+125°C
DC Voltage	+8 V
Continuous Input Power	+13 dBm
Short Term Input power (1 minute max.)	50 mW
Peak Power (3 µsec max.)	0.5 W
"S" Series Burn-In Temperature (case)	+125°C

### Thermal Data: $V_{CC} = +5 V_{DC}$

Parameter	Rating
Thermal Resistance $\theta_{jc}$	45°C/W
Transistor Power Dissipation $P_d$	0.051 W
Junction Temperature Rise Above Case $T_{jc}$	+2°C

\* Over temperature performance limits for part number CA16-2, guaranteed from 0°C to +50°C only.

**ADVANCED:** Data Sheets contain information regarding a product M/A-COM Technology Solutions is considering for development. Performance is based on target specifications, simulated results, and/or prototype measurements. Commitment to develop is not guaranteed.

**PRELIMINARY:** Data Sheets contain information regarding a product M/A-COM Technology Solutions has under development. Performance is based on engineering tests. Specifications are typical. Mechanical outline has been fixed. Engineering samples and/or test data may be available. Commitment to produce in volume is not guaranteed.

• **North America** Tel: 800.366.2266 • **Europe** Tel: +353.21.244.6400  
 • **India** Tel: +91.80.4155721 • **China** Tel: +86.21.2407.1588  
 Visit [www.macomtech.com](http://www.macomtech.com) for additional data sheets and product information.

M/A-COM Technology Solutions Inc and its affiliates reserve the right to make changes to the products and information contained herein without notice.

## Cascadable Amplifier 10 to 1200 MHz

Rev. V4

### Typical Performance Curves at +25°C

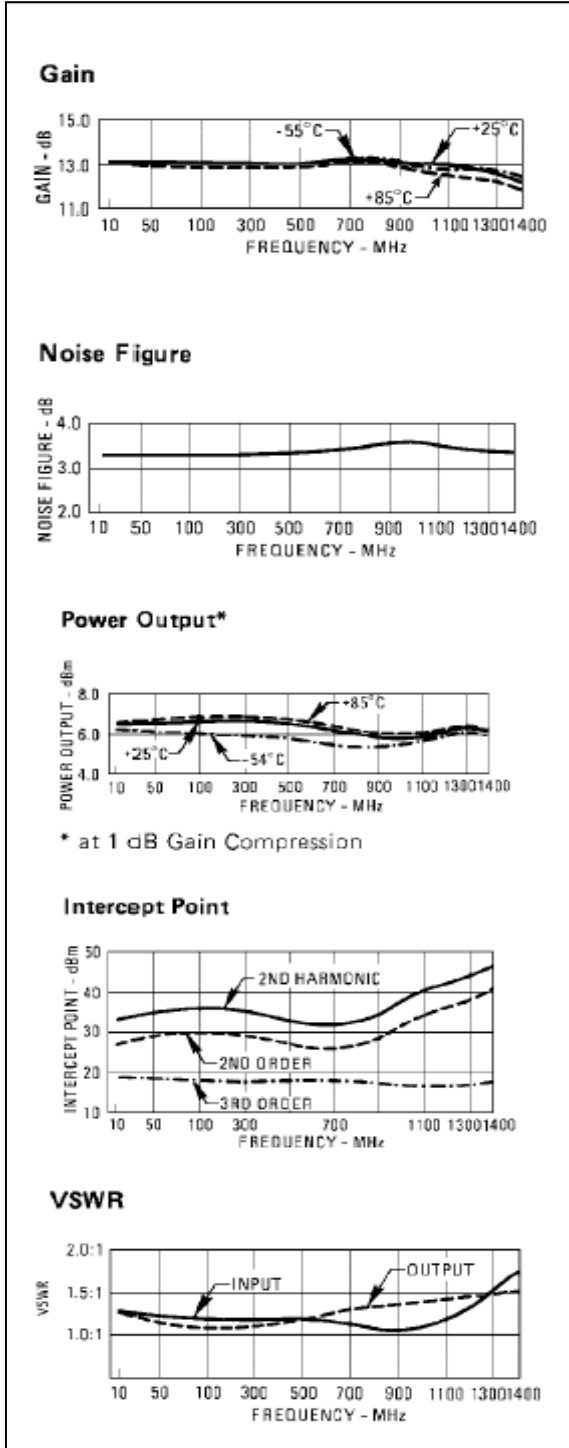

### Outline Drawing: TO-8 \*

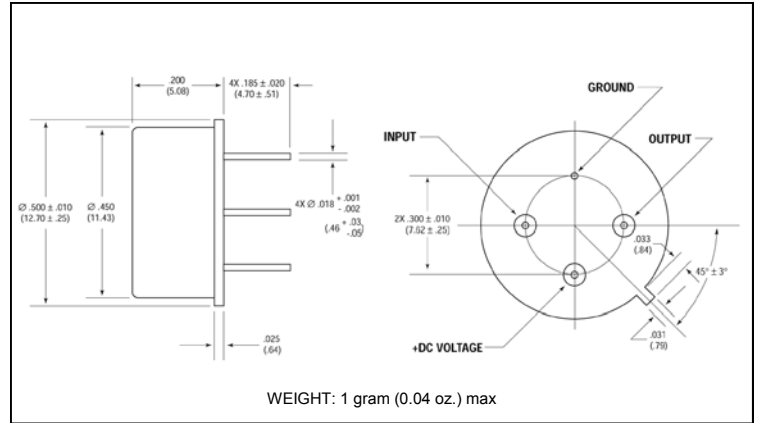

### Outline Drawing: Surface Mount \*

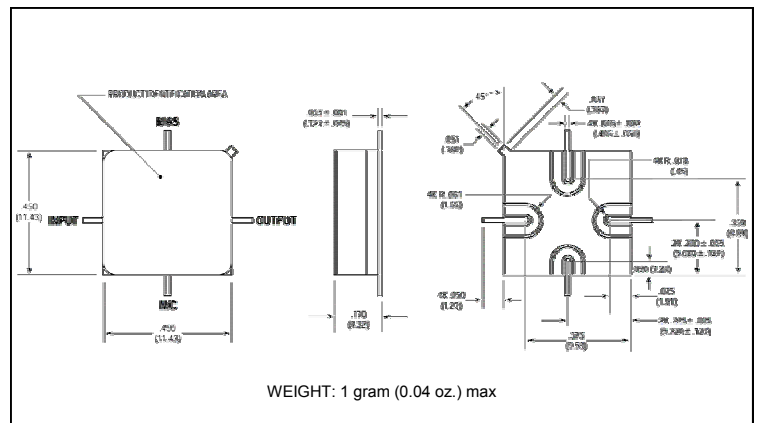

### Outline Drawing: SMA Connectorized \*

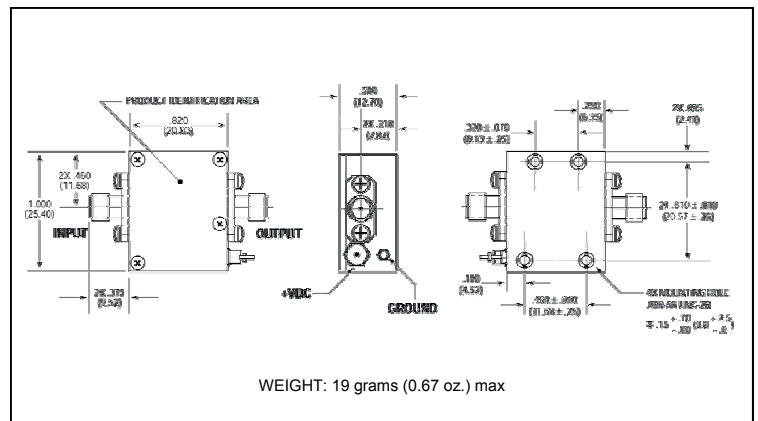

\* Dimensions are inches (millimeters) ±0.015 (0.38) unless otherwise specified.

**ADVANCED:** Data Sheets contain information regarding a product M/A-COM Technology Solutions is considering for development. Performance is based on target specifications, simulated results, and/or prototype measurements. Commitment to develop is not guaranteed.

**PRELIMINARY:** Data Sheets contain information regarding a product M/A-COM Technology Solutions has under development. Performance is based on engineering tests. Specifications are typical. Mechanical outline has been fixed. Engineering samples and/or test units may be available. Commitment to produce in volume is not guaranteed.

• **North America** Tel: 800.366.2266 • **Europe** Tel: +353.21.244.6400  
 • **India** Tel: +91.80.4155721 • **China** Tel: +86.21.2407.1588  
 Visit [www.macomtech.com](http://www.macomtech.com) for additional data sheets and product information.

M/A-COM Technology Solutions and its affiliates reserve the right to make changes to the products and information contained herein without notice.