

Features

- 20 V to 250 V Back Bias in Off State
- 200 mA Series Diode Bias Current at +25°C
- 50 mA Shunt Diode Bias Current at +25°C
- Propagation Delay less than 8 μ s
- Low Quiescent Current Consumption
- 3 V or 5 V CMOS Logic Control
- 7 mm QFN-16LD Package
- Tape and Reel Packaging Available
- RoHS* Compliant and 260°C Reflow Compatible

Description

The MADR-010574 switch driver is designed to work with M/A-COM Technology Solutions high power and high voltage PIN diodes. This driver consists of two independently controlled drivers which are able to provide 200 mA series / 50 mA shunt current to a series/shunt, series/shunt SPDT PIN diode switch. The back bias voltage is configurable from 20 V to 250 V. High voltage level shifters are integrated so that it can be easily controlled by 3 V or 5 V CMOS logic. While consuming low quiescent current, this driver has a typical delay of less than 8 μ s when driving 220 pF capacitor load. If needed, the switching speed can be improved by consuming more quiescent power.

This driver is packaged in a lead free 7 mm PQFN-16LD package and is available in tape and reel packaging for high volume applications.

Ordering Information

Part Number	Package
MADR-010574-000100	Bulk Packaging
MADR-010574-0001TR	1000 piece Reel
MADR-010574-001SMB	Sample Board with Driver & MA4P504-1072T Diodes

Functional Schematic

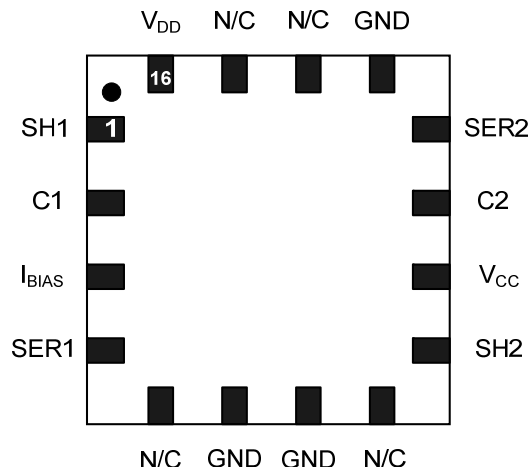

Pin Configuration ¹

Pin No.	Pin Name	Description
1	SH1	Shunt1
2	C1	Control Logic 1
3	I _{BIAS}	Bias Voltage
4	SER1	Series1
5	N/C ²	No Connection
6	GND	Ground
7	GND	Ground
8	N/C ²	No Connection
9	SH2	Shunt2
10	V _{CC}	Control Voltage
11	C2	Control Logic 2
12	SER2	Series2
13	GND	Ground
14	N/C ²	No Connection
15	N/C ²	No Connection
16	V _{DD}	Drain Voltage
17	Paddle	Ground

1. The paddle of the QFN package should be tied to ground.
2. N/C pins (except Pin 15) can be grounded. The clearance from high voltage pins should be at least 0.8 mm. Pin 15 must be left open.

* Restrictions on Hazardous Substances, European Union Directive 2002/95/EC.

ADVANCED: Data Sheets contain information regarding a product M/A-COM is considering for development. Performance is based on target specifications, simulated results, and/or prototype measurements. Commitment to develop is not guaranteed.

PRELIMINARY: Data Sheets contain information regarding a product M/A-COM has under development. Performance is based on engineering tests. Specifications are typical. Mechanical outline has been fixed. Engineering samples and/or test data may be available. Commitment to produce in volume is not guaranteed.

• **North America** Tel: 800.366.2266 / Fax: 978.366.2266
 • **Europe** Tel: 44.1908.574.200 / Fax: 44.1908.574.300
 • **Asia/Pacific** Tel: 81.44.844.8296 / Fax: 81.44.844.8298
 Visit www.macom.com for additional data sheets and product information.

M/A-COM Inc. and its affiliates reserve the right to make changes to the product(s) or information contained herein without notice.

Recommended Operating Conditions

Parameter	Test Conditions	Unit	Min.	Typ.	Max.
V_{CC}	Nominal $V_{CC} = 3.3\text{ V}$ Nominal $V_{CC} = 5.0\text{ V}$	V	3.0 4.5	3.3 5.0	3.6 5.5
V_{DD}	—	V	20	—	250
Control1, Control2 ³	Logic "0" Logic "1"	V	0.0 $0.7 \times V_{CC}$	0.0 V_{CC}	$0.3 \times V_{CC}$ V_{CC}
Series1/Series2 Sinking Current ⁴	-40°C +25°C +85°C	mA	—	—	300 200 150
Shunt1/Shunt2 Sinking Current ⁴	-40°C +25°C +85°C	mA	—	—	65 55 50
I_{BIAS} ^{5,6}	+25°C	μA	2	6	150
Operating Temperature	—	°C	-40	+25	+85

- Unused Controls should be either grounded or connected to V_{CC} . They should never be left open.
- Refer to "Application Circuit: Driving SPDT Switch with MA4P504-1072T Pin Diodes" for configuration of diode bias currents.
- This sinking bias current is necessary for normal driver operation. The easiest way is to connect a 0402 resistor R_{BIAS} between Pin V_{CC} and Pin I_{BIAS} . Then I_{BIAS} can be calculated by: $I_{BIAS} = (V_{CC}-0.6)/(500+R_{BIAS})$
- Refer to graph "Typ. Ton Driving 220 pF Caps vs. I_{BIAS} " on page 3 and the chart "Typ. IDD vs. I_{BIAS} at 25°C" on page 4 for the tradeoff between switching speed and power consumption.

Absolute Maximum Ratings^{7,8}

Parameter	Absolute Maximum
V_{CC}	-0.5 V to +7 V
V_{DD}	-0.5 V to 275 V
C1, C2 (Logic)	-0.5 V to 7 V
Series1/Series2 Sinking Current	
-40°C	550 mA
+25°C	450 mA
+85°C	350 mA
Shunt1/Shunt2 Sinking Current	
-40°C	150 mA
+25°C	150 mA
+85°C	100 mA
Series/Shunt Outputs Sourcing Current	25 mA
I_{BIAS}	500 μA
ESD HBM Rating	>1kV
Operating Temperature	-40 to +125°C
Storage Temperature	-55 to +150°C

- M/A-COM Technology Solutions does not recommend sustained operation near these survivability limits.
- Exceeding any one or combination of these limits may cause permanent damage to this device.

Truth Table⁹

C1	C2	Series1	Shunt1	Series2	Shunt2
0	0	Low	High	Low	High
0	1	Low	High	High	Low
1	0	High	Low	Low	High
1	1	High	Low	High	Low

- The actual voltage levels for "Low" and "High" are dependent on the current load to the driver. They can be estimated from the driver on resistance.

Powering On/Off Sequence:

V_{DD} should be turned on after V_{CC} , and the rise time of V_{DD} should be slower than 2.5 μs. When powering off, V_{DD} should be turned off before V_{CC} .

Electrical Specifications: $T_A = +25^\circ\text{C}$, $V_{CC} = 3.3\text{ V}$, $V_{DD} = 250\text{ V}$, $I_{BIAS} = 6\ \mu\text{A}^{10}$

Parameter	Test Conditions	Unit	Min.	Typ.	Max.
Quiescent Supply Currents	$V_{CC} (3.3\text{ V})^{11}$ $V_{DD} (250\text{ V})$	μA	—	6 25	10 37
Control Input Leakage Current	—	μA	—	—	1
Series Pull-down FET On Resistance	200 mA Load	Ω	—	9	11.4
Shunt Pull-down FET On Resistance	50 mA Load	Ω	—	26	30
Switching Speed Driving 220pF Caps: Series ¹² T_{ON} T_{OFF} T_r T_f	50% CTL to 95% Voltage 50% CTL to 5% Voltage 10% - 90% 90% - 10%	μs	—	6.2 0.22 5.1 0.1	—
Switching Speed Driving 220pF Caps: Shunt ¹² T_{ON} T_{OFF} T_r T_f	50% CTL to 95% Voltage 50% CTL to 5% Voltage 10% - 90% 90% - 10%	μs	—	3.1 0.2 2.6 0.08	—

10. The parameters were measured with 500 k Ω R_{BIAS} connecting between pin V_{CC} and pin I_{BIAS} .

11. I_{BIAS} is included in the quiescent V_{CC} current due to the bias configuration.

12. Switching parameters were measured driving 220 pF capacitors with no current load. Controls C1 and C2 were tied together. It will be faster when C2 is inverted from C1, which is case driving a SPDT switch.

Typ. T_{on} Driving 220pF Caps vs VDD
 $V_{CC} = 3.3\text{V}$, $I_{BIAS} = 6\ \mu\text{A}$, 25°C

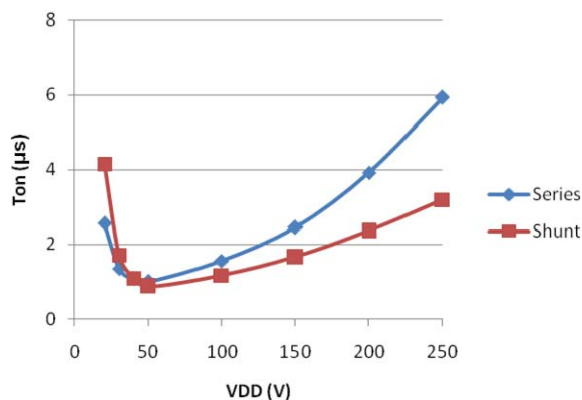

Typ. T_{on} Driving 220pF Caps vs I_{BIAS}
 $V_{CC} = 3.3\text{V}$, $V_{DD} = 250\text{V}$, 25°C

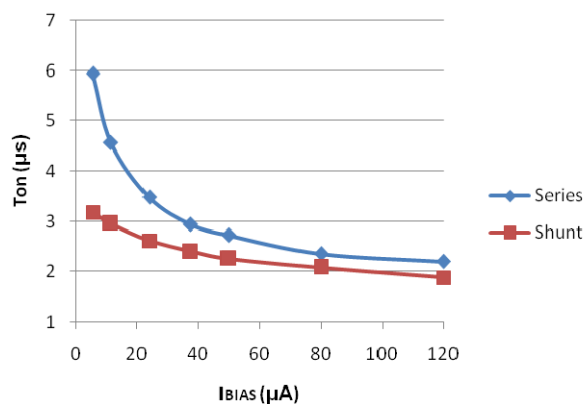

Performance Driving M/A-COM MA4P504-1072T PIN Diode SPDT Switch ¹³

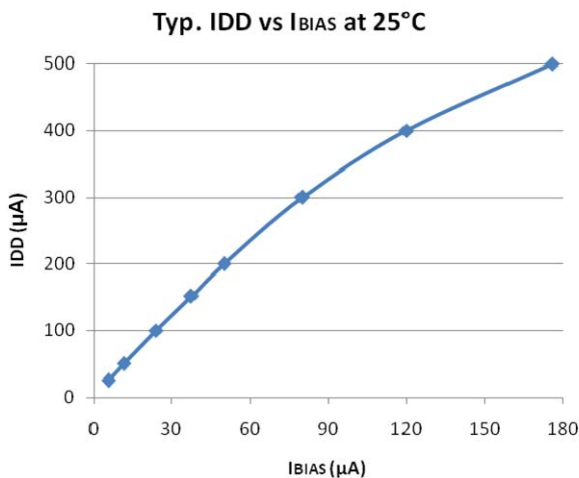
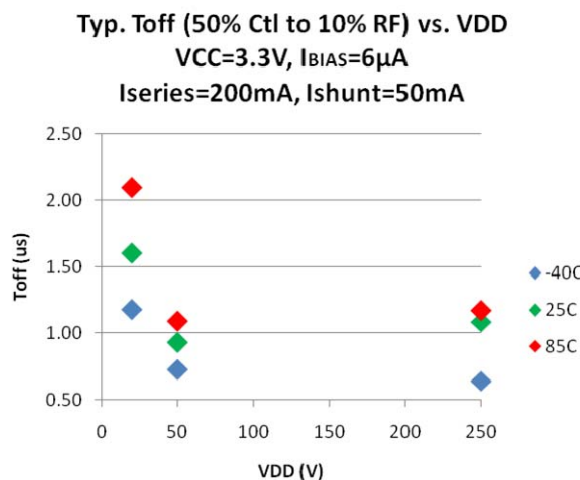
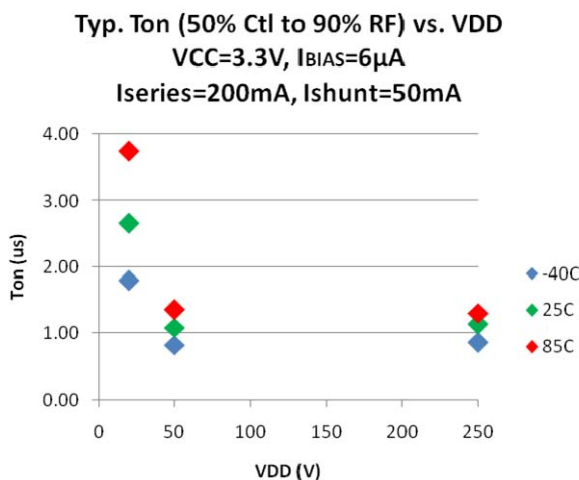
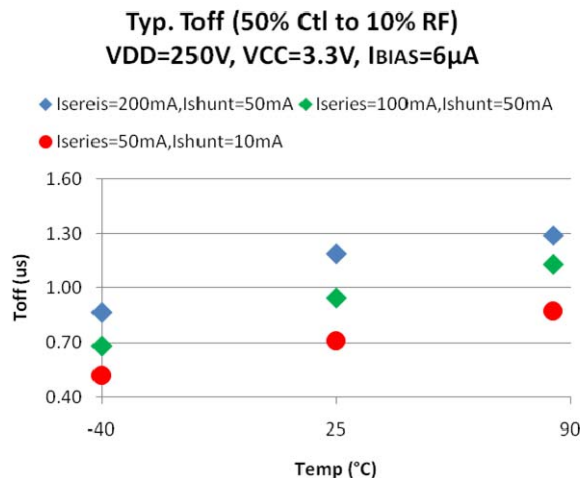
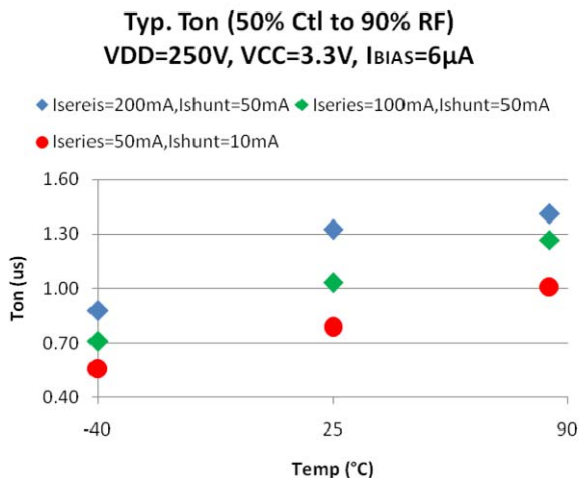

13. The switch is a series/shunt, series/shunt SPDT switch using four M/A-COM MA4P504-1072T PIN diodes. Schematic is on next page. Switching parameters were measured with 500 MHz 20W CW RF signal.

Application Circuit: Driving SPDT Switch with MA4P504-1072T PIN Diodes ¹⁴

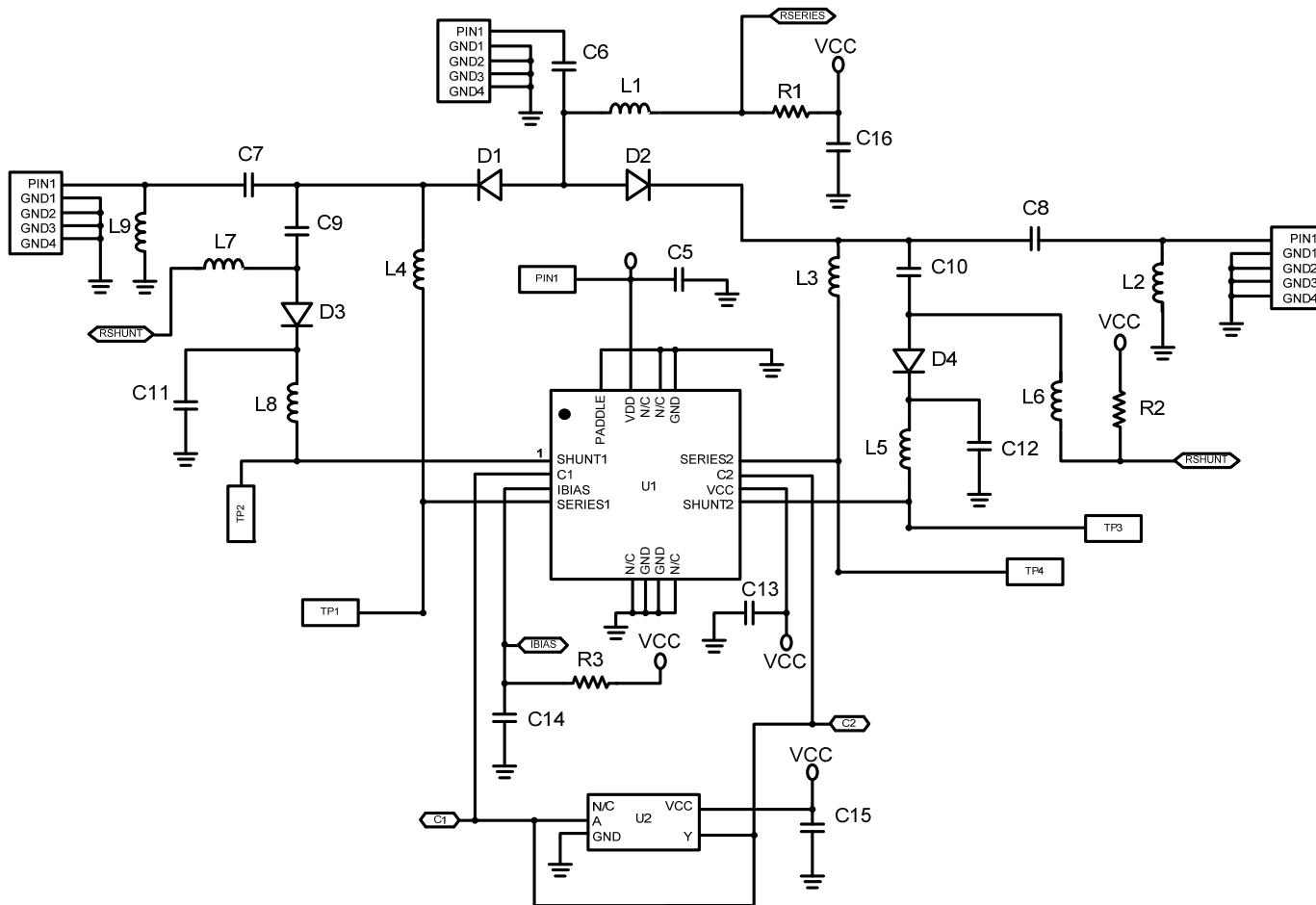

14. This is the schematic of MADR-010547-001SMB. The frequency range for this application circuit is 200 MHz to 500 MHz. The bias current for the series diodes is 200 mA. The bias current for the shunt diodes is 50 mA. The recommended inductors are Coil Craft 0603LS-181XJLB for both current and frequency considerations. For different frequency applications, both capacitors and inductors should be adjusted accordingly.

Recommended PCB

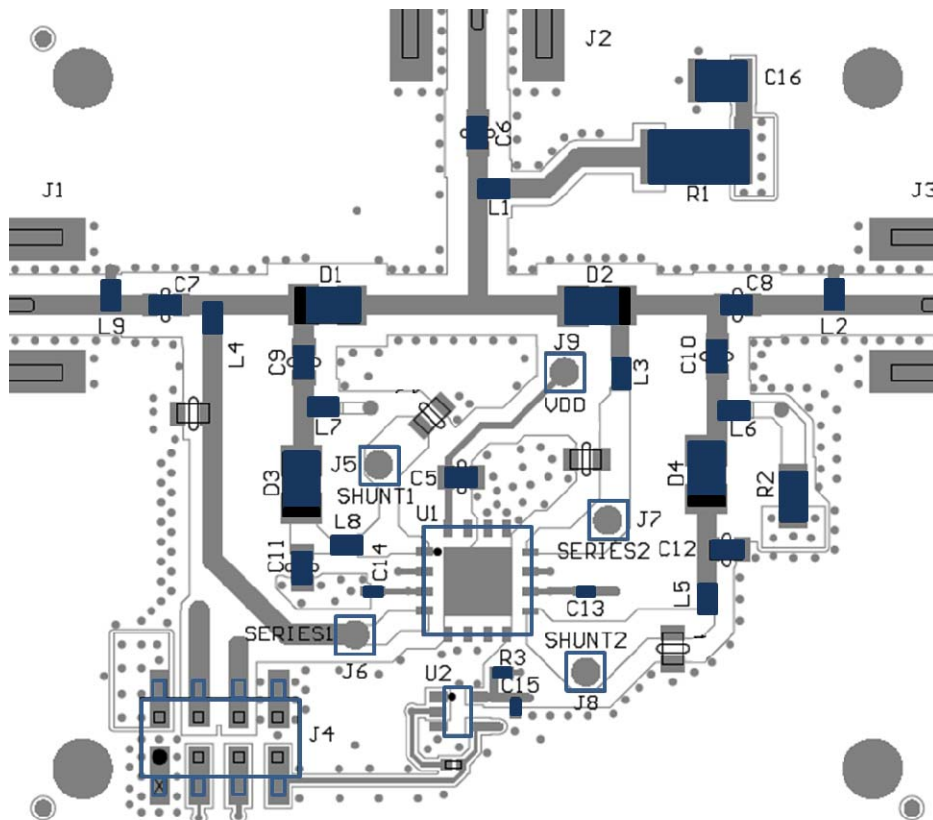

Parts List

Part	Value	Size
C5	0.01 μ F, 500 V	0805
C6 - C12	100 pF, 500 V	0805
C13 - C15	0.1 μ F, 16 V	0402
L1 - L8	180 nH	0603
R1	1.5 Ω , 1 W	2512
R2	15 Ω , 0.5 W	1206
R3	499 K Ω , 1/16 W	0402
D1 - D4	MA4P504-1072	

Footprint

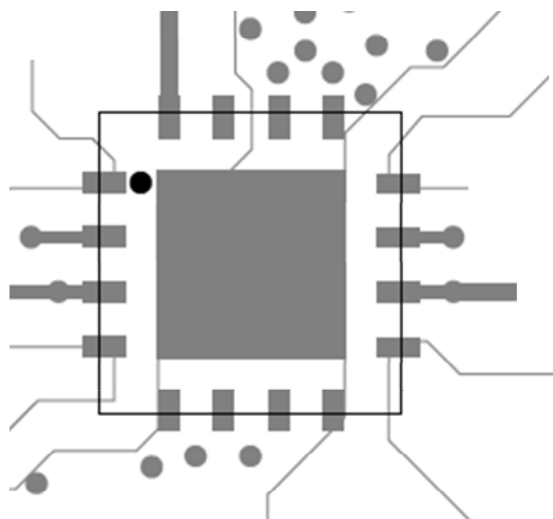

Lead Free 7mm PQFN-16LD †

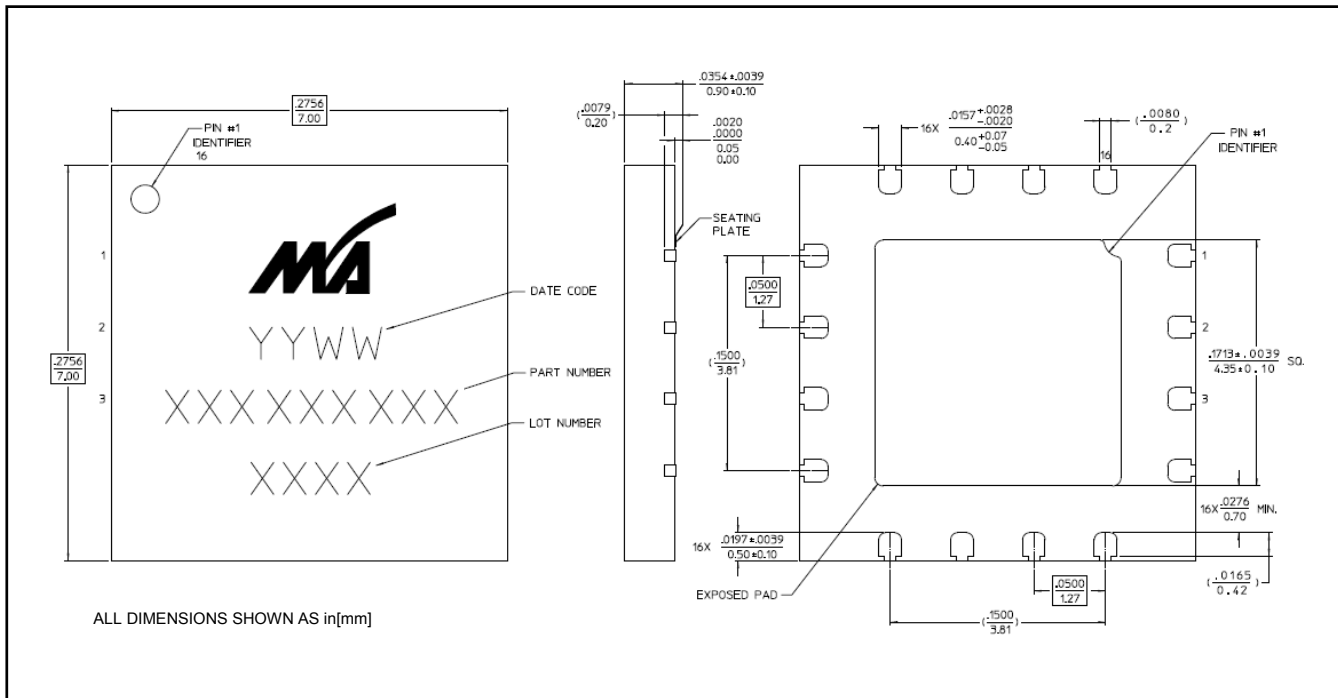

† This is not a JEDEC standard package. Please refer to Application Note for footprint and lead-free solder reflow recommendations.

Handling Procedures

Please observe the following precautions to avoid damage:

Static Sensitivity

Silicon Circuits are sensitive to electrostatic discharge (ESD) and can be damaged by static electricity. Proper ESD control techniques should be used when handling these devices.