

XM1001-QH



Image Reject Mixer
10.0-33.0 GHz

Rev. V1
MimiX Broadband

Features

- Fundamental Image Reject Mixer
- 9.0 dB Conversion Loss
- 20.0 dB Image Rejection
- +25.0 dBm Input Third Order Intercept (IIP3)
- 4x4 mm, QFN
- RoHS* Compliant and 260°C Reflow Compatible

Description

M/A-COM Tech's 10.0-33.0 GHz GaAs MMIC fundamental image reject mixer with high linearity has a conversion loss of 9.0 dB with a 20.0 dB image rejection across the band. I and Q mixer outputs are provided and an external 90 degree hybrid is required to select the desired sideband. This MMIC uses M/A-COM Tech's GaAs PHEMT device model technology, and is based upon electron beam lithography to ensure high repeatability and uniformity. The device comes in a low-cost 4x4 mm QFN surface mount plastic package. This device is well suited for Millimeter-wave Point-to-Point Radio, LMDS, SATCOM and VSAT applications.

Functional Block Diagram

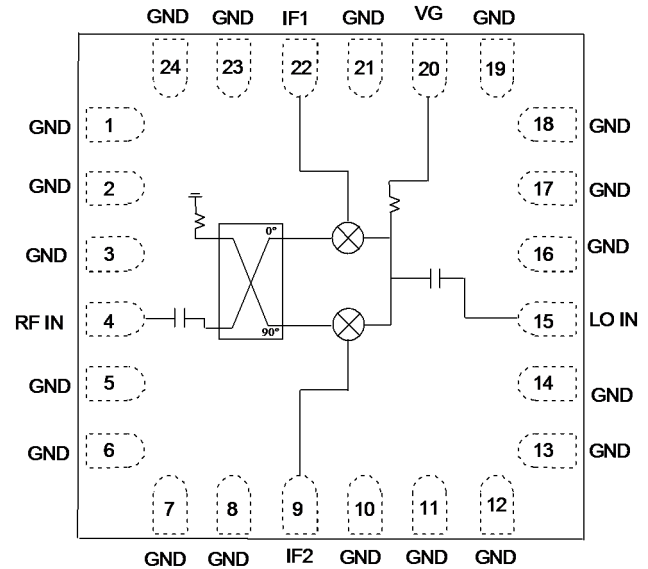

Pin Configuration

Pin No.	Function	Pin No.	Function
1-3	GND	16-19	GND
4	RF IN	20	VG
5-8	GND	21	GND
9	IF2	22	IF2
10-14	GND	23-24	GND
15	LO IN		

Absolute Maximum Ratings

Parameter	Absolute Max.
Gate Bias Voltage (Vg)	+0.3 VDC
Input Power (RF Pin)	+20.0 dBm
Input Power (IF Pin)	+20.0 dBm
Storage Temperature (Tstg)	-65 °C to +165 °C
Operating Temperature (Ta)	-55 °C to +125 °C

Ordering Information

Part Number	Package
XM1001-QH-0G00	bulk quantity
XM1001-QH-0G0T	tape and reel
XM1001-QH-EV1	evaluation module

XM1001-QH



Image Reject Mixer
10.0-33.0 GHz

Rev. V1
MimiX Broadband

Electrical Specifications: 10-33 GHz (Ambient Temperature T = 25°C)

Parameter	Units	Min.	Typ.	Max.
Frequency Range (RF)	GHz	10.0	-	33.0
Frequency Range (LO)	GHz	8.0	-	36.0
Frequency Range (IF)	GHz	DC	-	4.0
RF Return Loss (S11)	dB	-	10.0	-
IF Return Loss (S22)	dB	-	TBD	-
LO Return Loss (S33)	dB	-	TBD	-
Conversion Loss (S21)	dB	-	9.0	-
LO Input Drive (P _{LO})	dBm	12.0	15.0	18.0
Image Rejection	dBc	-	20.0	-
Isolation LO/RF	dB	-	16.0	-
Isolation LO/IF	dB	-	TBD	-
Isolation RF/IF	dB	-	TBD	-
Input Third Order Intercept (IIP3)	dBm	-	+25.0	-
Gate Bias Voltage (Vg1)	VDC	-2.0	-0.5	+0.1

ADVANCED: Data Sheets contain information regarding a product M/A-COM Technology Solutions is considering for development. Performance is based on target specifications, simulated results, and/or prototype measurements. Commitment to develop is not guaranteed.

PRELIMINARY: Data Sheets contain information regarding a product M/A-COM Technology Solutions has under development. Performance is based on engineering tests. Specifications are typical. Mechanical outline has been fixed. Engineering samples and/or test data may be available. Commitment to produce in volume is not guaranteed.

• **North America** Tel: 800.366.2266 • **Europe** Tel: +353.21.244.6400
• **India** Tel: +91.80.43537383 • **China** Tel: +86.21.2407.1588
Visit www.macomtech.com for additional data sheets and product information.

M/A-COM Technology Solutions Inc and its affiliates reserve the right to make changes to the product(s) or information contained herein without notice.

Typical Performance Curves

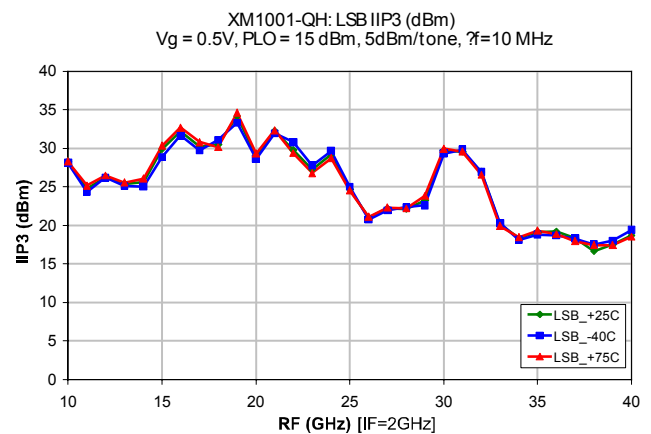
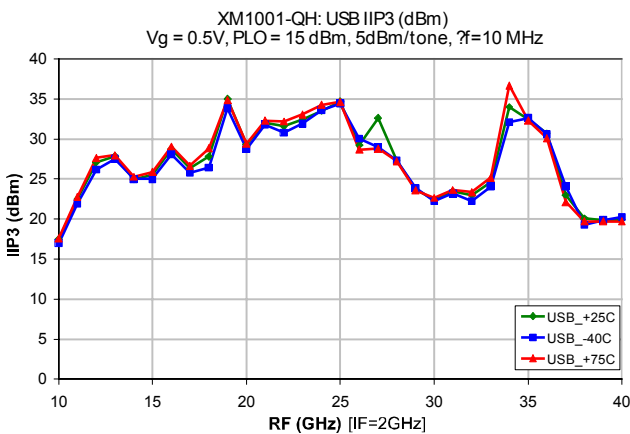
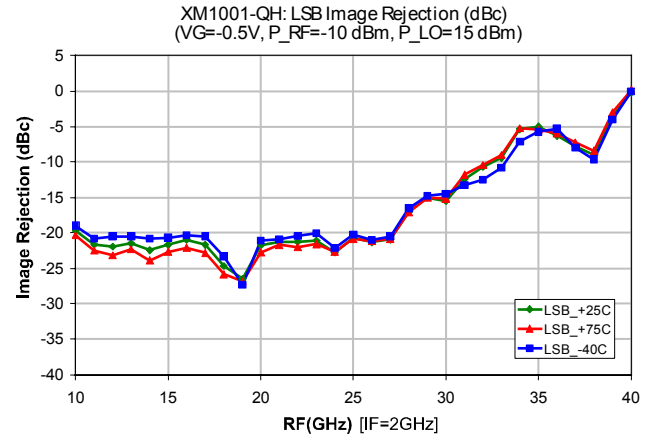
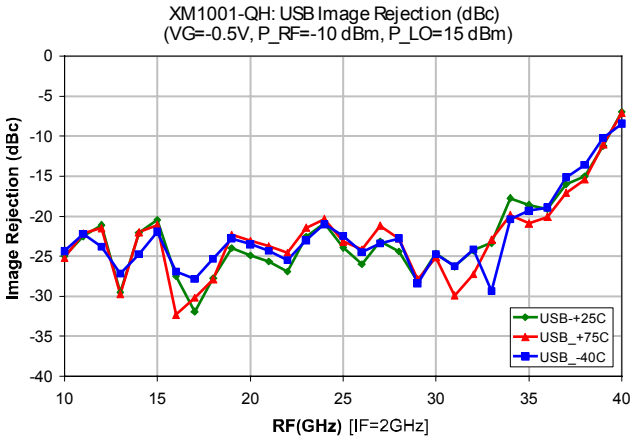
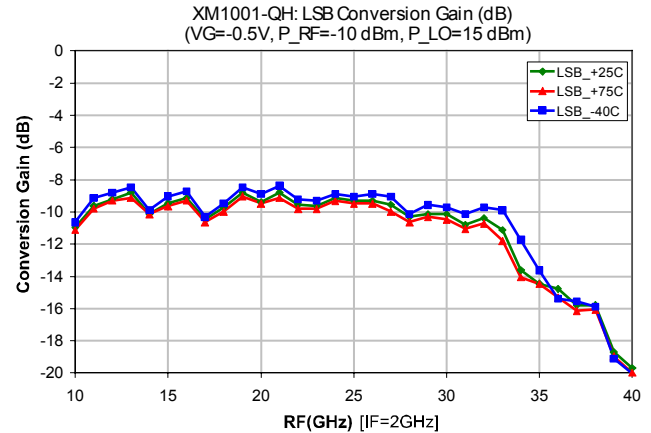
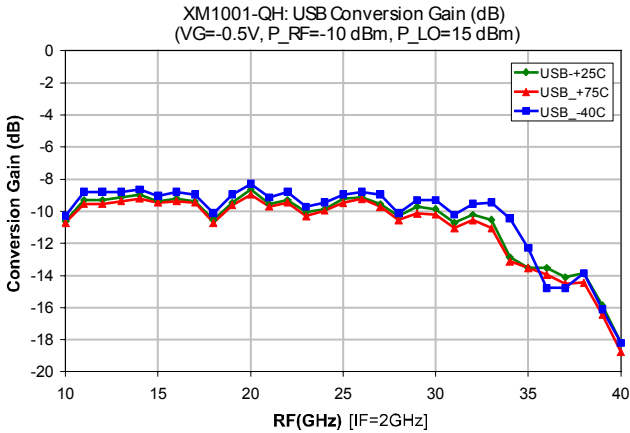

XM1001-QH



Image Reject Mixer
10.0-33.0 GHz

Rev. V1
MimiX Broadband

Typical Performance Curves (cont.)

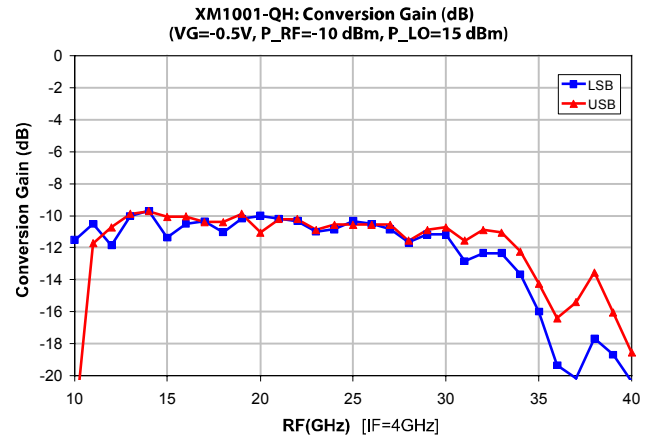
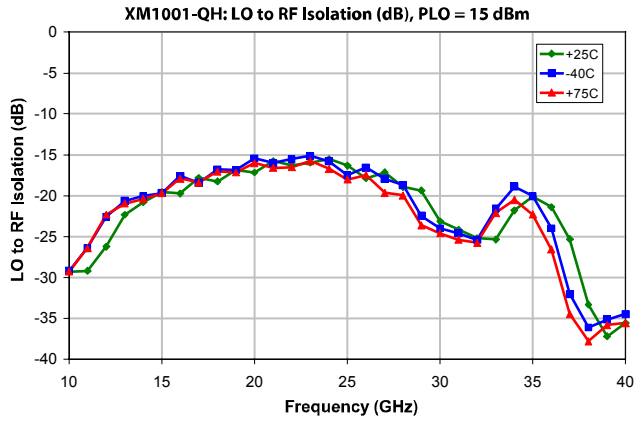

ADVANCED: Data Sheets contain information regarding a product M/A-COM Technology Solutions is considering for development. Performance is based on target specifications, simulated results, and/or prototype measurements. Commitment to develop is not guaranteed.
PRELIMINARY: Data Sheets contain information regarding a product M/A-COM Technology Solutions has under development. Performance is based on engineering tests. Specifications are typical. Mechanical outline has been fixed. Engineering samples and/or test data may be available. Commitment to produce in volume is not guaranteed.

• **North America** Tel: 800.366.2266 • **Europe** Tel: +353.21.244.6400
• **India** Tel: +91.80.43537383 • **China** Tel: +86.21.2407.1588
Visit www.macomtech.com for additional data sheets and product information.

M/A-COM Technology Solutions Inc and its affiliates reserve the right to make changes to the product(s) or information contained herein without notice.

App Note [3] USB/LSB Selection -

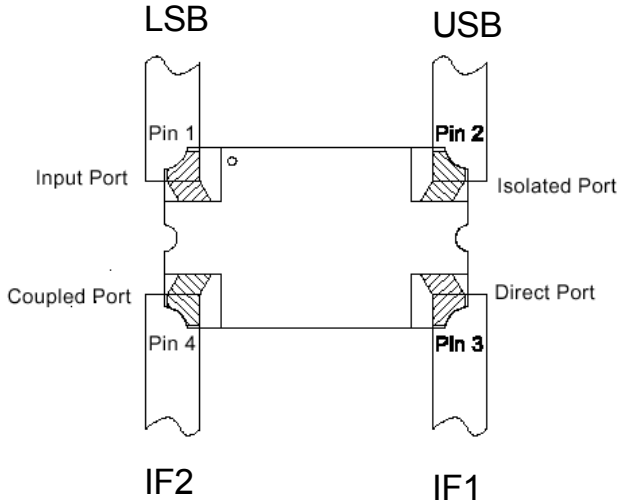

For Upper Side Band Operation (USB): With IF1 and IF2 connected to the direct port (0°) and coupled port (90°) respectively as shown in the diagram, the USB signal will reside on the isolated port. The input port must be loaded with 50 ohms.

For Lower Side Band Operation (LSB): With IF1 and IF2 connected to the direct port (0°) and coupled port (90°) respectively as shown in the diagram, the LSB signal will reside on the input port. The isolated port must be loaded with 50 ohms.

Note: The coupled port can be used as an alternative input but the port location of the Coupled and Direct ports reverse.

An alternate method of Selection of USB or LSB:

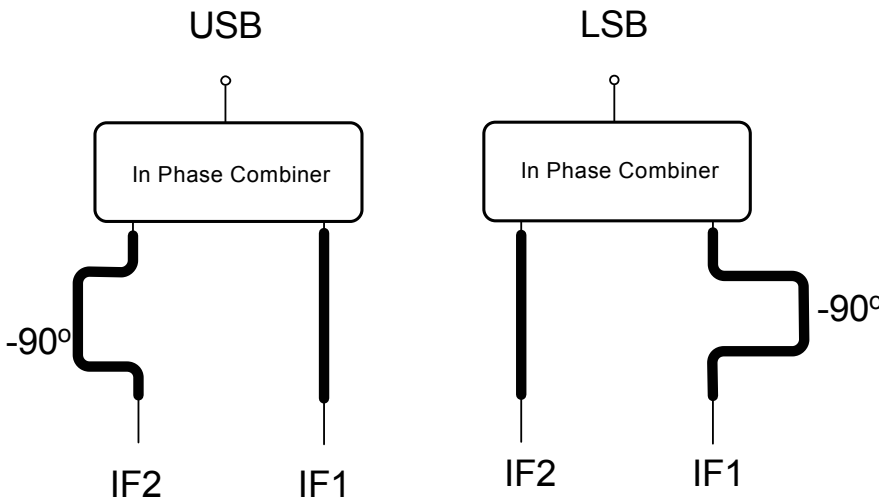

Lead-Free Package Dimensions/Layout

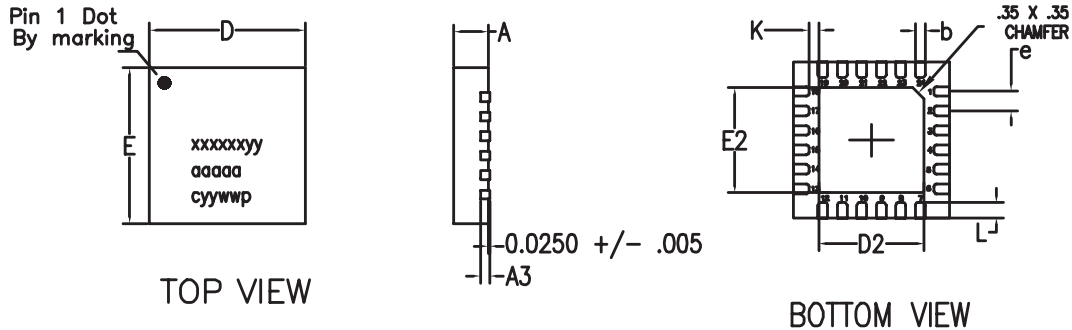

MARKINGS:
PIN 1/BOM REV/Pb FREE SYM
MIMIX PART/MODEL NO.
WAFER LOT NUMBER
DATE CODE

NOTES:
1. DIMENSIONS ARE IN MM.

RECOMMENDED SOLDER PAD PITCH AND DIMENSIONS

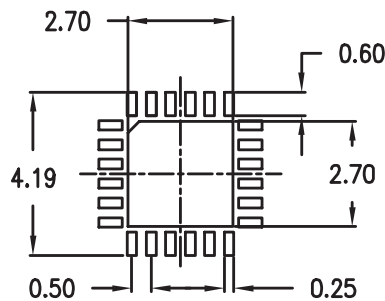

	MIN	TYP	MAX
A	0.80	0.90	1.00
A3	0.20 REF		
b	0.20	0.25	0.30
K	0.20	-	-
D	4.00 BSC		
E	4.00 BSC		
e	0.50		
D2	2.45	2.60	2.75
E2	2.45	2.60	2.75
L	0.20	0.30	0.40

1. VIEWS ARE NOT TO SCALE: USE DIMENSIONS AND TABLE.

Handling Procedures

Please observe the following precautions to avoid damage:

Static Sensitivity

Gallium Arsenide Integrated Circuits are sensitive to electrostatic discharge (ESD) and can be damaged by static electricity. Proper ESD control techniques should be used when handling these devices.