

PRELIMINARY
 Notice: This is not a final specification.
 Some parametric limits are subject to change.

MITSUBISHI RECTIFIER DIODE FD5000AV-100DA

**HIGH-POWER, GENERAL USE
 PRESS PACK TYPE**

FD5000AV-100DA



- VRRM Repetitive peak reverse voltage 5000V
- IF(AV) Average forward current 5000A

OUTLINE DRAWING

Dimensions in mm

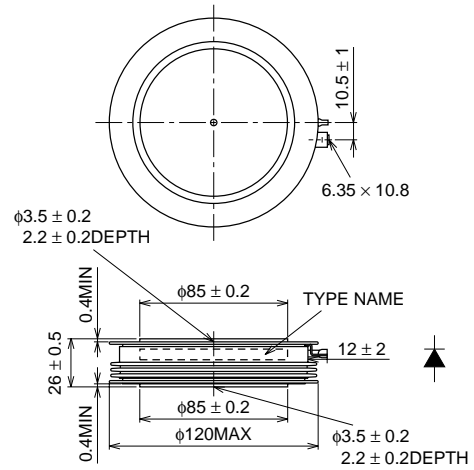

APPLICATION

- High-power inverters
- Fly-hwheel diode for GCT Thyristor
- Power supplies as high frequency rectifiers

MAXIMUM RATINGS

Symbol	Parameter	Conditions	Voltage class	Unit
VRRM	Repetitive peak reverse voltage	—	5000	V
VRSM	Non-repetitive peak reverse voltage	—	5000	V
VR(DC)	DC reverse voltage	—	2000	V

Symbol	Parameter	Conditions	Ratings	Unit
IF(RMS)	RMS forward current	Applied for all condition angles	7850	A
IF(AV)	Average forward current	f = 60Hz, sinewave $\theta = 180^\circ$, $T_f = 70^\circ\text{C}$	5000	A
IFSM	Surge forward current	One half cycle at 60Hz, $T_j = 150^\circ\text{C}$ start	70	kA
I ² t	Current-squared, time integration		2.0×10^7	A ² s
T _j	Operation junction temperature		-40 ~ 150	°C
T _{stg}	Storage temperature		-40 ~ 150	°C
—	Mounting force required	(Recommended value 47kN)	39 ~ 55	kN
—	Weight	Typical value 1450g	—	g

ELECTRICAL CHARACTERISTICS

Symbol	Parameter	Test conditions	Limits			Unit
			Min.	Typ.	Max.	
V _{FM}	Forward voltage	I _{FM} = 7000A, T _j = 150°C	—	—	1.6	V
I _{RRM}	Repetitive peak reverse current	V _{RM} = 5000V, T _j = 150°C	—	—	200	mA
R _{th(j-f)}	Thermal resistance	Junction to Fin	—	—	0.0071	K/W

PRELIMINARY
Notice: This is not a final specification.
Some parametric limits are subject to change.

PERFORMANCE CURVES

