



Five-Channel Power Supply Supervisors



FEATURES

- Five-channel supply voltage detection
- 2 V_{DD} inputs allow monitoring of +5.0V, +3.3V, +3.0V, +2.5V or +1.8V supplies
- 3 adjustable voltage inputs allow monitoring supplies > 0.6V
- 70ms minimum reset delay
- Manual reset capability
- Reset signals valid down to $V_{DD} = 1V$
- Accurate $\pm < 2\%$ voltage threshold
- Power-supply transients suppressed
- Low 2 μ A maximum supply current at 5V
- RoHS-compliant MSOP package

APPLICATIONS

- Telecom & datacom systems
- Routers & servers
- Data storage equipment
- Set-top boxes
- Multi-voltage systems

DESCRIPTION

The CAT885 is a five-channel power supply supervisory circuit with high reset threshold accuracy and very low power consumption. The device features an open-drain output, active-low function with manual reset to perform basic system reset and monitoring functions for a wide range of electronic products. The CAT885 monitors five system voltages by maintaining a reset output active until all the power supply voltages exceed the specified trip values. The device then maintains the reset output in an active condition until the internal timer times out, which allows the system power supplies to stabilize.

Two of the five voltage detectors are factory set for standard supplies, while the threshold voltages of the third, fourth, and fifth voltage monitors can be adjusted for specific system design requirements using external resistors.

The CAT885 lowers system costs and saves board space by integrating five channels into a single, small MSOP 8-lead package.

For Ordering Information details see page 7.

PIN CONFIGURATION

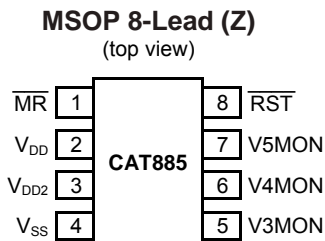

See page 2 for pin functions

TYPICAL APPLICATION

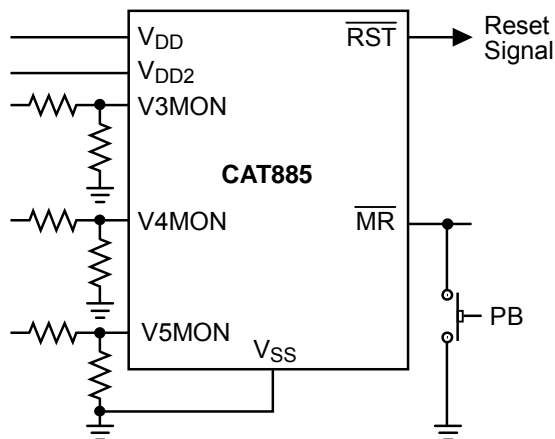

FUNCTIONAL BLOCK DIAGRAM

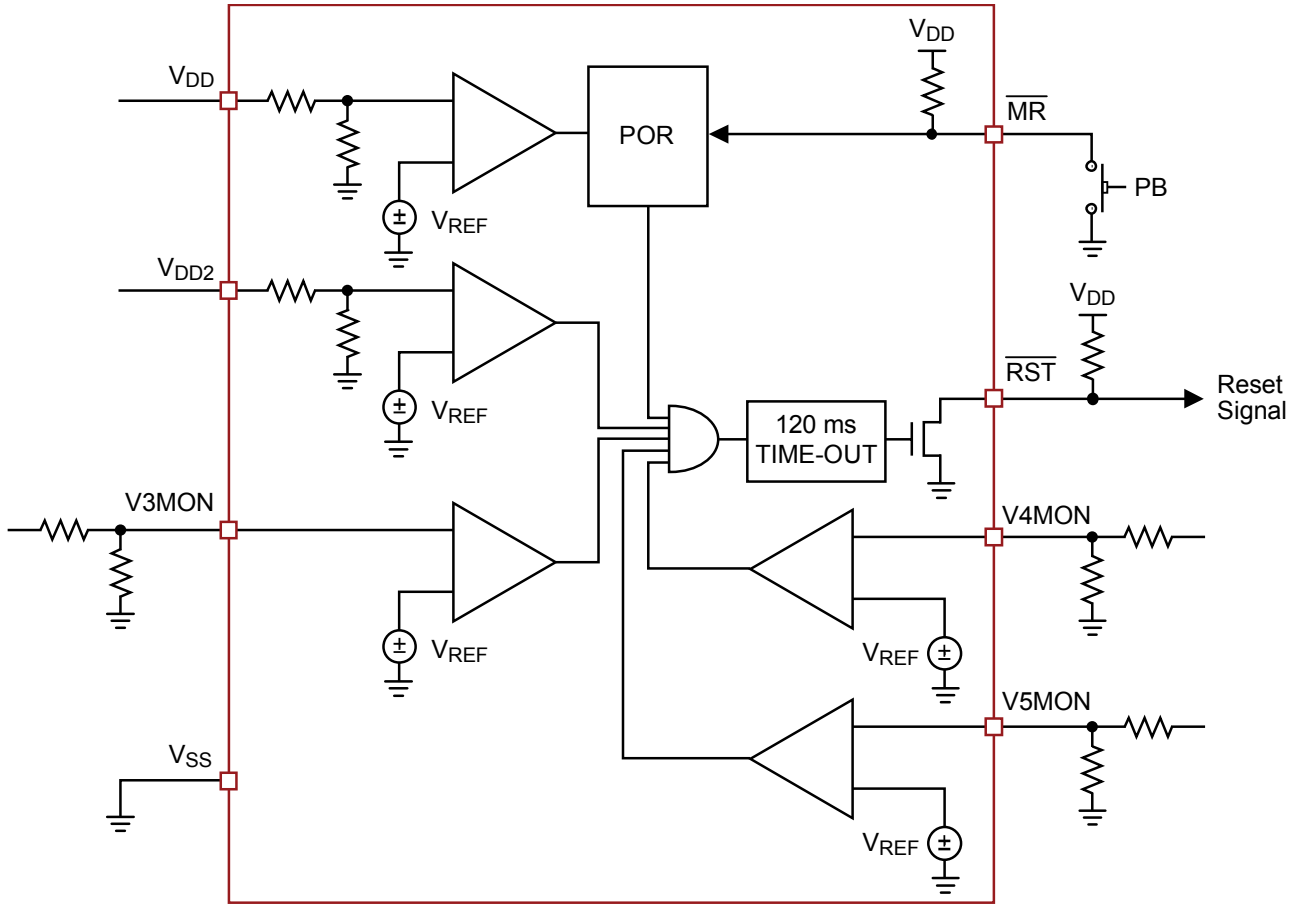

PIN FUNCTIONS

Pin #	Pin	Function
1	\overline{MR}	Active-low manual reset Input with internal pull-up resistor
2	V_{DD}	Chip supply, first preset under-voltage detector input
3	V_{DD2}	Second preset under-voltage detector input
4	V_{SS}	Ground
5	V3MON	Adjustable third under-voltage detector input
6	V4MON	Adjustable fourth under-voltage detector input
7	V5MON	Adjustable fifth under-voltage detector input
8	\overline{RST}	Active-low open drain reset output, use external resistor

ABSOLUTE MAXIMUM RATINGS⁽¹⁾

Parameters	Ratings	Units
Temperature under Bias	-40 to +125	°C
Voltage on any Pin with Respect to V_{SS}	-1.0 to +7.0	V
DC Output Current	5	mA
Thermal Resistance θ_{JA} for MSOP Package ⁽²⁾	145	°C/W

RECOMMENDED OPERATING CONDITIONS

Parameters	Ratings	Units
Operating Temperature Range (Industrial)	-40 to +85	°C
Storage Temperature	-65 to +150	°C
Lead Soldering Temperature (10 seconds)	+300	°C

ELECTRICAL CHARACTERISTICS

Over the recommended operating conditions unless otherwise specified.

Symbol	Parameter	Conditions	Min	Typ.	Max	Units
V_{DD}	Supply Voltage Range		1.5		5.5	V
I_{DD1}	V_{DD} Supply Current	$V_{DD} = 5.0V$		2	9	μA
I_{DD2}	V_{DD2} Input Current	$V_{DD2} = 3.3V$		0.5	3	μA
I_{DDX}	V3, V4, V5MON Input Current	V3, V4, V5MON = 1.0V		15	50	nA
Voltage Thresholds						
V_{TH1}	Fixed Voltage Trip Point for V_{DD}	CAT885Lx	4.55	4.63	4.72	V
		CAT885Sx	2.81	2.87	2.92	V
$V_{TH1HYST}$	Hysteresis of V_{TH1}	$V_{TH1} = 4.63V$		50		mV
		$V_{TH1} = 2.87V$		30		mV
V_{TH2}	Fixed Voltage Trip Point for V_{DD2}	CAT885xT	3.02	3.08	3.13	V
		CAT885xS	2.90	2.95	3.01	V
		CAT885xZ	2.29	2.33	2.37	V
		CAT885xA	1.65	1.68	1.71	V
$V_{TH2HYST}$	Hysteresis of V_{TH2}	$V_{TH2} = 3.08V$		40		mV
		$V_{TH2} = 2.95V$		30		mV
		$V_{TH2} = 2.33V$		25		mV
		$V_{TH2} = 1.68V$		20		mV
V_{REF}	V3MON, V4MON, V5MON Adj. Reset Threshold Voltage	V_{TH} for V3, V4, V5MON	0.585	0.598	0.611	V
$V_{REFHYST}$	Hysteresis Voltage			3		mV

Notes:

- Stresses above those listed under "Absolute Maximum Ratings" may cause permanent damage to the device. These are stress ratings only and functional operation of the devices at these or any other conditions outside of those listed in the operational sections of this specification is not implied. Exposure to any absolute maximum rating for extended periods may affect device performance and reliability.
- θ_{JA} is measured with the component mounted on a high effective thermal conductivity test board in free air.

ELECTRICAL CHARACTERISTICS (continued)

Symbol	Parameter	Conditions	Min	Typ.	Max	Units
Reset						
V _{OL}	Reset Output Voltage Low	V _{DD} ≥ 3.3V, Sinking 2.5mA		0.05	0.40	V
		V _{DD} < 3.3V, Sinking 1.5mA		0.05	0.40	V
t _{RPD}	V _{TH} to Reset Asserted Delay		1	6		μs
t _{PD}	POR Timeout Delay		70	120	240	ms
C _{LOAD}	Load Capacitance on Reset Pin			5		pF
Manual Reset						
V _{THL}	$\overline{\text{MR}}$ Input Voltage Low				0.8	V
V _{THH}	$\overline{\text{MR}}$ Input Voltage High		V _{DD} - 0.6			V
T _{PW}	$\overline{\text{MR}}$ Minimum Pulse Width		1			μs
R _{IN}	Internal Pull-Up Resistor		8		16	kΩ

OPERATION

The CAT885 is designed to monitor critical supply voltages in line driven and battery powered microprocessor systems, providing Supply Voltage Supervision, Power On Reset control and Manual Reset Assertion. These features along with excellent threshold accuracy and low power consumption make the CAT885 device suitable for a wide variety of applications needing multi-voltage monitoring.

CAT885 allows users to adjust the minimum voltage sense level for three of the five monitored voltages. For example, the user can adjust the voltage input trip point for V_{3MON}, V_{4MON} and V_{5MON} inputs. This is done by connecting an external resistor divider network to the V_{xMON} pin in order to set the trip point to a voltage above 600mV. Resistors R₁ and R₂ in Figure 1 are selected by the formula: $V_{\text{TRIP}} = 0.6V \times (R_1 + R_2) / R_2$.

During normal operation, the CAT885 monitors the voltage levels of V_{DD}, V_{2MON}, V_{3MON}, V_{4MON}, and V_{5MON}. If the voltage on any of these five inputs falls below their respective voltage trip points, a reset is asserted ($\overline{\text{RST}} = \text{low}$) to prevent the microprocessor from operating during a power failure or brownout condition. This reset signal remains low until the voltages exceeds the voltage threshold settings for the reset time delay period t_{PD}.

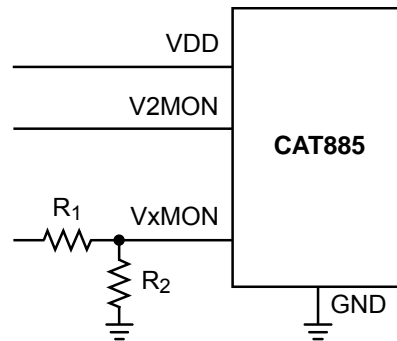

Figure 1. CAT885 Programming Trip Voltage

POWER ON RESET (POR)

Applying power to the CAT885 activates a POR circuit which activates the reset output (active LOW). At power-up POR prevents the system microprocessor from starting to operate with insufficient voltage and prior to stabilization of the clock oscillator. It ensures that operation is precluded until internal registers are properly loaded, FPGA's have downloaded their configuration data prior and all system power supplies are above minimum operating levels and stable. The reset signal remains active until V_{DD} rises above the minimum preset voltage level for time period t_{PD} .

MANUAL RESET

The manual-reset input (\overline{MR}) allows the user to trigger a reset by using a push-button switch or by electronically driving the input low. The MR input is an active LOW debounced input. Reset is asserted anytime the MR pin is pulled low to less than 100mV for the minimum MR pulse width or longer. The reset output remains asserted low for t_{PD} , typically 120ms and then is released. Figures 2 and 3 illustrate the CAT885's operation and RST output response times.

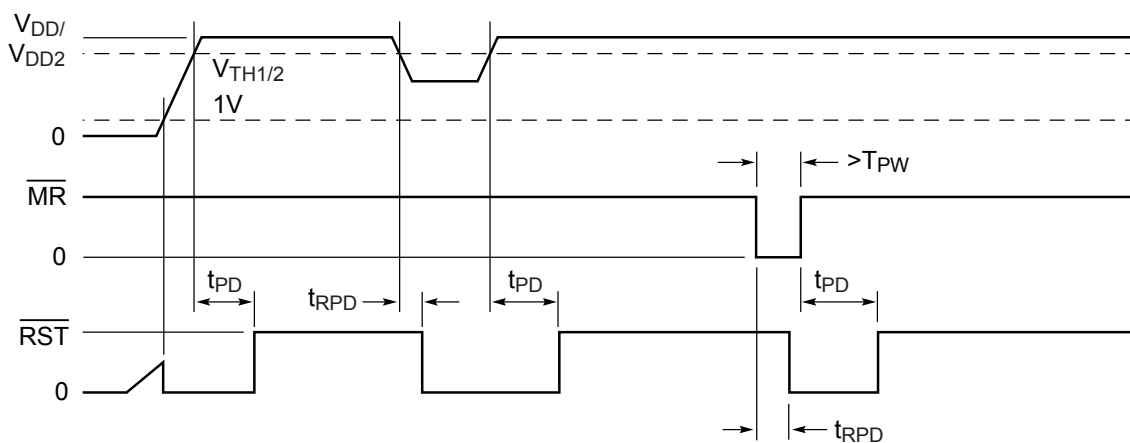

Figure 2. Power Supply Monitoring Diagram

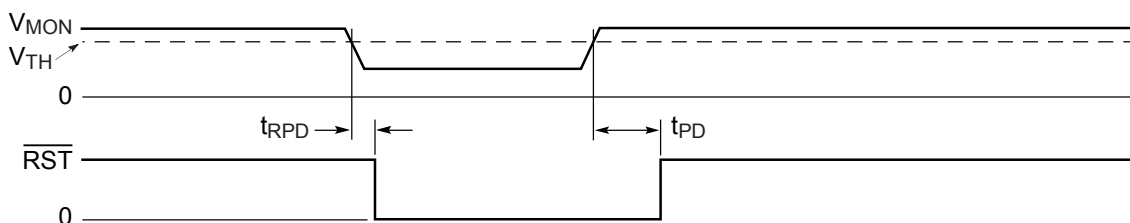
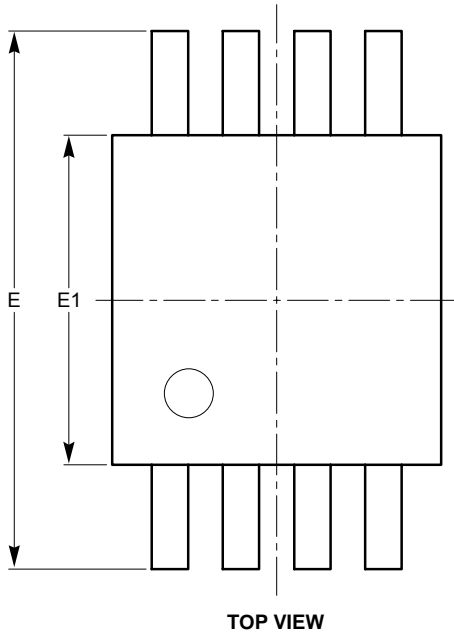

Figure 3. Auxillary Voltage Monitoring Diagram

PACKAGE OUTLINE DRAWING

MSOP 8-Lead 3 x 3mm (Z) ⁽¹⁾⁽²⁾



SYMBOL	MIN	NOM	MAX
A			1.10
A1	0.05	0.10	0.15
A2	0.75	0.85	0.95
b	0.22		0.38
c	0.13		0.23
D	2.90	3.00	3.10
E	4.80	4.90	5.00
E1	2.90	3.00	3.10
e	0.65 BSC		
L	0.40	0.60	0.80
L1	0.95 REF		
L2	0.25 BSC		
θ	0°		6°

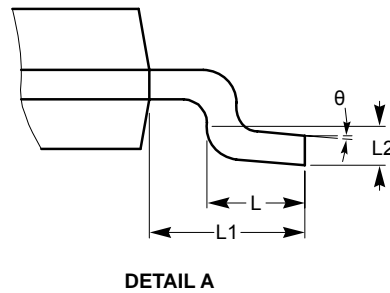
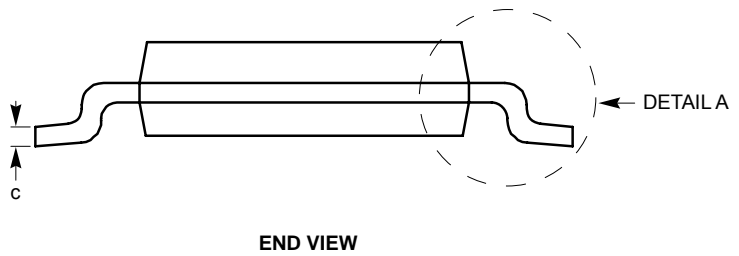
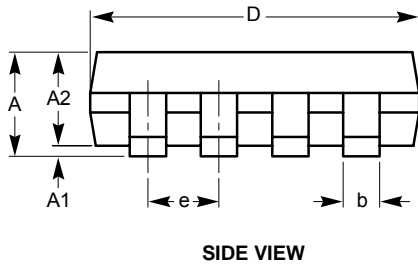

Notes:

- (1) All dimensions are in millimeters. Angles in degrees.
- (2) Complies with JEDEC standard MO-187.

EXAMPLE OF ORDERING INFORMATION

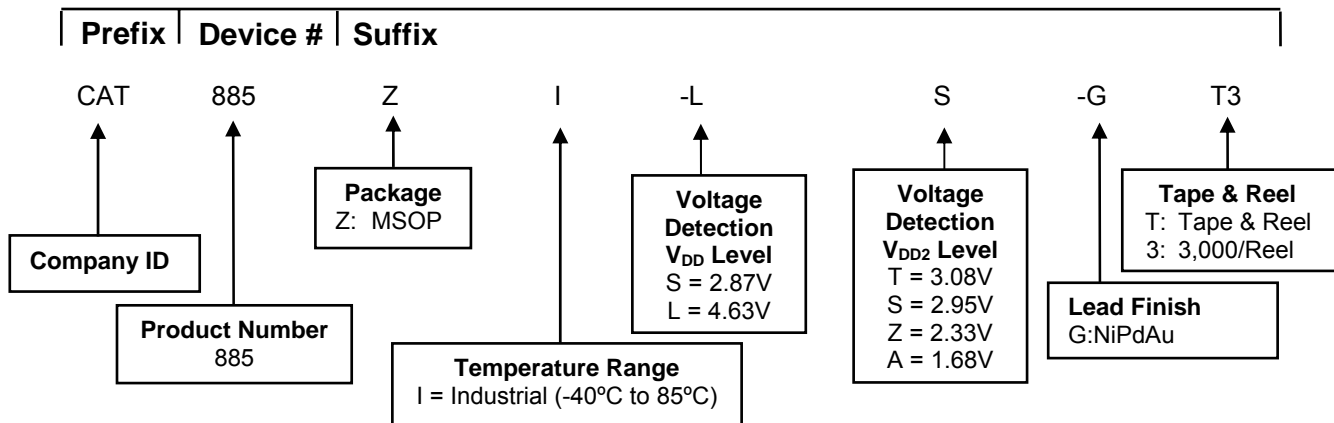

ORDERING INFORMATION

Part Number	V _{DD}	V _{DD2}	Package
CAT885ZI-ST-GT3	2.87V	3.08V	MSOP
CAT885ZI-SS-GT3	2.87V	2.95V	MSOP
CAT885ZI-SZ-GT3	2.87V	2.33V	MSOP
CAT885ZI-SA-GT3	2.87V	1.68V	MSOP
CAT885ZI-LT-GT3	4.63V	3.08V	MSOP
CAT885ZI-LS-GT3	4.63V	2.95V	MSOP
CAT885ZI-LZ-GT3	4.63V	2.33V	MSOP
CAT885ZI-LA-GT3	4.63V	1.68V	MSOP

Notes:

- (1) All packages are RoHS-compliant (Lead-free, Halogen-free).
- (2) The standard finish is NiPdAu.
- (3) The device used in the above example is a CAT885ZI-LS-GT3 (MSOP, Industrial Temperature, 4.63V (V_{DD}) and 2.95V (V_{DD2}) Detection Levels, NiPdAu, Tape & Reel, 3,000/Reel).
- (4) For additional detection voltage, package and temperature options, please contact your nearest ON Semiconductor Sales office.

REVISION HISTORY

Date	Rev.	Description
05-May-08	A	Initial Release
06-Nov-08	B	Change logo and fine print to ON Semiconductor
03-Aug-09	C	Update Functional Block Diagram

ON Semiconductor and  are registered trademarks of Semiconductor Components Industries, LLC (SCILLC). SCILLC reserves the right to make changes without further notice to any products herein. SCILLC makes no warranty, representation or guarantee regarding the suitability of its products for any particular purpose, nor does SCILLC assume any liability arising out of the application or use of any product or circuit, and specifically disclaims any and all liability, including without limitation special, consequential or incidental damages. "Typical" parameters which may be provided in SCILLC data sheets and/or specifications can and do vary in different applications and actual performance may vary over time. All operating parameters, including "Typicals" must be validated for each customer application by customer's technical experts. SCILLC does not convey any license under its patent rights nor the rights of others. SCILLC products are not designed, intended, or authorized for use as components in systems intended for surgical implant into the body, or other applications intended to support or sustain life, or for any other application in which the failure of the SCILLC product could create a situation where personal injury or death may occur. Should Buyer purchase or use SCILLC products for any such unintended or unauthorized application, Buyer shall indemnify and hold SCILLC and its officers, employees, subsidiaries, affiliates, and distributors harmless against all claims, costs, damages, and expenses, and reasonable attorney fees arising out of, directly or indirectly, any claim of personal injury or death associated with such unintended or unauthorized use, even if such claim alleges that SCILLC was negligent regarding the design or manufacture of the part. SCILLC is an Equal Opportunity/Affirmative Action Employer. This literature is subject to all applicable copyright laws and is not for resale in any manner.

PUBLICATION ORDERING INFORMATION

LITERATURE FULFILLMENT:

Literature Distribution Center for ON Semiconductor
 P.O. Box 5163, Denver, Colorado 80217 USA
Phone: 303-675-2175 or 800-344-3860 Toll Free USA/Canada
Fax: 303-675-2176 or 800-344-3867 Toll Free USA/Canada
Email: orderlit@onsemi.com

N. American Technical Support: 800-282-9855 Toll Free
 USA/Canada
Europe, Middle East and Africa Technical Support:
 Phone: 421 33 790 2910
Japan Customer Focus Center:
 Phone: 81-3-5773-3850

ON Semiconductor Website: www.onsemi.com
Order Literature: <http://www.onsemi.com/orderlit>
 For additional information, please contact your local Sales Representative