

# MC100EL91

## 5 V Triple PECL Input to -5 V ECL Output Translator

### Description

The MC100EL91 is a triple PECL input to ECL output translator. The device receives standard voltage differential PECL signals, determined by the  $V_{CC}$  supply level, and translates them to differential -5 V ECL output signals. (For translation of LVPECL to -3.3 V ECL output, see MC100LVEL91.)

To accomplish the level translation, the EL91 requires three power rails. The  $V_{CC}$  supply should be connected to the positive supply, and the  $V_{EE}$  pin should be connected to the negative power supply. The GND pins are connected to the system ground plane. Both  $V_{EE}$  and  $V_{CC}$  should be bypassed to ground via 0.01  $\mu$ F capacitors.

Under open input conditions, the  $\bar{D}$  input will be biased at  $V_{CC}/2$  and the D input will be pulled to GND. This condition will force the Q output to a low, ensuring stability.

The  $V_{BB}$  pin, an internally generated voltage supply, is available to this device only. For single-ended input conditions, the unused differential input is connected to  $V_{BB}$  as a switching reference voltage.  $V_{BB}$  may also rebias AC coupled inputs. When used, decouple  $V_{BB}$  and  $V_{CC}$  via a 0.01  $\mu$ F capacitor and limit current sourcing or sinking to 0.5 mA. When not used,  $V_{BB}$  should be left open.

### Features

- 670 ps Typical Propagation Delay
- ESD Protection: >2 kV Human Body Model
- The 100 Series Contains Temperature Compensation
- Operating Range:  $V_{CC} = 4.75$  V to 5.5 V;  
 $V_{EE} = -4.2$  V to -5.5 V; GND = 0 V
- Internal Input Pulldown Resistors
- Q Output will Default LOW with Inputs Open or at GND
- Meets or Exceeds JEDEC Spec EIA/JESD78 IC Latchup Test
- Moisture Sensitivity Level 1  
For Additional Information, see Application Note AND8003/D
- Flammability Rating: UL 94 V-0 @ 0.125 in,  
Oxygen Index: 28 to 34
- Transistor Count = 282 devices
- Pb-Free Package is Available\*



ON Semiconductor®

<http://onsemi.com>

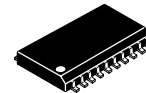

SO-20 WB  
DW SUFFIX  
CASE 751D

### MARKING DIAGRAM\*

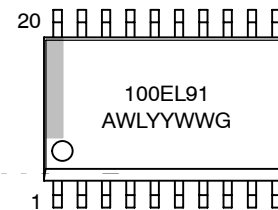

A = Assembly Location  
WL = Wafer Lot  
YY = Year  
WW = Work Week  
G = Pb-Free Package

\*For additional marking information, refer to Application Note AND8002/D.

### ORDERING INFORMATION

See detailed ordering and shipping information in the package dimensions section on page 5 of this data sheet.

\*For additional information on our Pb-Free strategy and soldering details, please download the ON Semiconductor Soldering and Mounting Techniques Reference Manual, SOLDERRM/D.

# MC100EL91

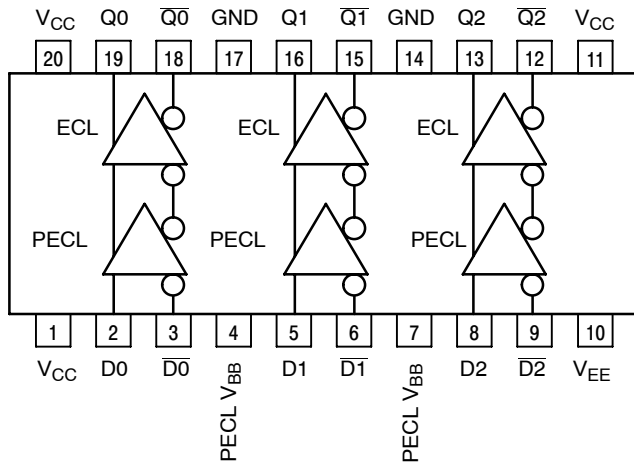

**Table 1. PIN DESCRIPTION**

| PIN                 | FUNCTION                      |
|---------------------|-------------------------------|
| Dn, $\overline{Dn}$ | PECL Inputs                   |
| Qn, $\overline{Qn}$ | ECL Outputs                   |
| PECL $V_{BB}$       | PECL Reference Voltage Output |
| $V_{CC}$            | Positive Supply               |
| $V_{EE}$            | Negative Supply               |
| GND                 | Ground                        |

\*\*All  $V_{CC}$  pins are tied together on the die.

Warning: All  $V_{CC}$ ,  $V_{EE}$ , and GND pins must be externally connected to Power Supply to guarantee proper operation.

**Figure 1. 20-Lead Pinout (Top View) and Logic Diagram**

**Table 2. MAXIMUM RATINGS**

| Symbol        | Parameter                                | Condition 1         | Condition 2  | Rating      | Unit                           |
|---------------|--|---------------------|--|-------------|--------------------------------|
| $V_{CC}$      | PECL Power Supply                        | GND = 0 V           |  | 8 to 0      | V                              |
| $V_{EE}$      | NECL Power Supply                        | GND = 0 V           |  | -8 to 0     | V                              |
| $V_I$         | PECL Input Voltage                       | GND = 0 V           | $V_I \leq V_{CC}$  | 6 to 0      | V                              |
| $I_{out}$     | Output Current                           | Continuous<br>Surge |  | 50<br>100   | mA<br>mA                       |
| $I_{BB}$      | PECL $V_{BB}$ Sink/Source                |                     |  | $\pm 0.5$   | mA                             |
| $T_A$         | Operating Temperature Range              |                     |  | -40 to +85  | $^{\circ}C$                    |
| $T_{stg}$     | Storage Temperature Range                |                     |  | -65 to +150 | $^{\circ}C$                    |
| $\theta_{JA}$ | Thermal Resistance (Junction-to-Ambient) | 0 lfpm<br>500 lfpm  | SOIC-20 WB<br>SOIC-20 WB                                       | 90<br>60    | $^{\circ}C/W$<br>$^{\circ}C/W$ |
| $\theta_{JC}$ | Thermal Resistance (Junction-to-Case)    | Standard Board      | SOIC-20 WB   | 30 to 35    | $^{\circ}C/W$                  |
| $T_{sol}$     | Wave Solder                              | Pb<br>Pb-Free       | <2 to 3 sec @ 248 $^{\circ}C$<br><2 to 3 sec @ 260 $^{\circ}C$ | 265<br>265  | $^{\circ}C$                    |

Stresses exceeding Maximum Ratings may damage the device. Maximum Ratings are stress ratings only. Functional operation above the Recommended Operating Conditions is not implied. Extended exposure to stresses above the Recommended Operating Conditions may affect device reliability.

# MC100EL91

**Table 3. PECL INPUT DC CHARACTERISTICS**  $V_{CC}= 5.0\text{ V}$ ;  $V_{EE}= -5.0\text{ V}$ ;  $GND= 0\text{ V}$  (Note 1)

| Symbol        | Characteristic  | -40°C      |     |            | 25°C       |     |            | 85°C       |     |            | Unit          |
|---------------|---|------------|-----|------------|------------|-----|------------|------------|-----|------------|---------------|
|               |   | Min        | Typ | Max        | Min        | Typ | Max        | Min        | Typ | Max        |               |
| $I_{CC}$      | $V_{CC}$ Power Supply Current   |            |     | 11         |            | 6   | 11         |            |     | 11         | mA            |
| $V_{IH}$      | Input HIGH Voltage (Single-Ended)   | 3835       |     | 4120       | 3835       |     | 4120       | 3835       |     | 4120       | mV            |
| $V_{IL}$      | Input LOW Voltage (Single-Ended)  | 3190       |     | 3525       | 3190       |     | 3525       | 3190       |     | 3525       | mV            |
| PECL $V_{BB}$ | Output Voltage Reference  | 3.62       |     | 3.74       | 3.62       |     | 3.74       | 3.62       |     | 3.74       | V             |
| $V_{IHCMR}$   | Input HIGH Voltage Common Mode Range (Differential) (Note 2)<br>$V_{PP} < 500\text{ mV}$<br>$V_{PP} \geq 500\text{ mV}$ | 1.3<br>1.5 |     | 4.8<br>4.8 | 1.2<br>1.4 |     | 4.8<br>4.8 | 1.2<br>1.4 |     | 4.8<br>4.8 | V             |
| $I_{IH}$      | Input HIGH Current  |            |     | 150        |            |     | 150        |            |     | 150        | $\mu\text{A}$ |
| $I_{IL}$      | Input LOW Current   | 0.5        |     |            | 0.5        |     |            | 0.5        |     |            | $\mu\text{A}$ |

NOTE: Device will meet the specifications after thermal equilibrium has been established when mounted in a test socket or printed circuit board with maintained transverse airflow greater than 500 lfpm. Electrical parameters are guaranteed only over the declared operating temperature range. Functional operation of the device exceeding these conditions is not implied. Device specification limit values are applied individually under normal operating conditions and not valid simultaneously.

1. Input parameters vary 1:1 with  $V_{CC}$ .  $V_{CC} = +4.75\text{ V}$  to  $+5.2\text{ V}$ ,  $V_{EE} = -4.20\text{ V}$  to  $-5.5\text{ V}$ .
2.  $V_{IHCMR}$  min varies 1:1 with  $GND$ .  $V_{IHCMR}$  max varies 1:1 with  $V_{CC}$ .

**Table 4. NECL OUTPUT DC CHARACTERISTICS**  $V_{CC}= 5.0\text{ V}$  to  $5.0\text{ V}$ ;  $V_{EE}= -5.0\text{ V}$ ;  $GND= 0\text{ V}$  (Note 3)

| Symbol   | Characteristic                | -40°C |       |       | 25°C  |       |       | 85°C  |       |       | Unit |
|----------|-------------------------------|-------|-------|-------|-------|-------|-------|-------|-------|-------|------|
|          |                               | Min   | Typ   | Max   | Min   | Typ   | Max   | Min   | Typ   | Max   |      |
| $I_{EE}$ | $V_{EE}$ Power Supply Current |       |       | 28    |       | 22    | 28    |       |       | 30    | mA   |
| $V_{OH}$ | Output HIGH Voltage (Note 4)  | -1085 | -1005 | -880  | -1025 | -955  | -880  | -1025 | -955  | -880  | mV   |
| $V_{OL}$ | Output LOW Voltage (Note 4)   | -1830 | -1695 | -1555 | -1810 | -1705 | -1620 | -1810 | -1705 | -1620 | mV   |

NOTE: Device will meet the specifications after thermal equilibrium has been established when mounted in a test socket or printed circuit board with maintained transverse airflow greater than 500 lfpm. Electrical parameters are guaranteed only over the declared operating temperature range. Functional operation of the device exceeding these conditions is not implied. Device specification limit values are applied individually under normal operating conditions and not valid simultaneously.

3. Output parameters vary 1:1 with  $GND$ .  $V_{CC} = +4.75\text{ V}$  to  $+5.2\text{ V}$ ,  $V_{EE} = -4.20\text{ V}$  to  $-5.5\text{ V}$ .
4. Outputs are terminated through a  $50\ \Omega$  resistor to  $GND - 2.0\text{ V}$

# MC100EL91

**Table 5. AC CHARACTERISTICS**  $V_{CC} = 5.0\text{ V}$ ;  $V_{EE} = -5.0\text{ V}$ ;  $GND = 0\text{ V}$  (Note 8).

| Symbol                 | Characteristic  | -40°C      |            |            | 25°C       |            |            | 85°C       |            |            | Unit    |
|------------------------|---|------------|------------|------------|------------|------------|------------|------------|------------|------------|---------|
|                        |   | Min        | Typ        | Max        | Min        | Typ        | Max        | Min        | Typ        | Max        |         |
| $f_{\max}$             | Maximum Toggle Frequency  |            | 700        |            |            | 700        |            |            | 700        |            | MHz     |
| $t_{PLH}$<br>$t_{PHL}$ | Propagation Delay D to Q<br>Differential<br>Single-Ended.   | 540<br>490 | 640<br>640 | 740<br>790 | 570<br>520 | 670<br>670 | 770<br>820 | 610<br>560 | 710<br>710 | 810<br>860 | ps      |
| $t_{SKEW}$             | Skew<br>Output-to-Output (Note 5)<br>Part-to-Part (Differential) (Note 5)<br>Duty Cycle (Differential) (Note 6) |            | 40<br>25   | 100<br>200 |            | 40<br>25   | 100<br>200 |            | 40<br>25   | 100<br>200 | ps      |
| $t_{JITTER}$           | Random Clock Jitter @ 700 MHz   |            | 1.2        |            |            | 1.2        |            |            | 1.2        |            | pS(RMS) |
| $V_{PP}$               | Input Swing (Note 7)  | 200        |            | 1000       | 200        |            | 1000       | 200        |            | 1000       | mV      |
| $t_r$<br>$t_f$         | Output Rise/Fall Times Q<br>(20% - 80%)   | 270        | 400        | 530        | 270        | 400        | 530        | 270        | 400        | 530        | ps      |

NOTE: Device will meet the specifications after thermal equilibrium has been established when mounted in a test socket or printed circuit board with maintained transverse airflow greater than 500 lpm. Electrical parameters are guaranteed only over the declared operating temperature range. Functional operation of the device exceeding these conditions is not implied. Device specification limit values are applied individually under normal operating conditions and not valid simultaneously.

5. Skews are valid across specified voltage range, part-to-part skew is for a given temperature.
6. Duty cycle skew is the difference between a  $t_{PLH}$  and  $t_{PHL}$  propagation delay through a device.
7.  $V_{PP}(\min)$  is the minimum input swing for which AC parameters are guaranteed. The device has a DC gain of  $\approx 40$ .
8.  $V_{CC} = +4.75\text{ V}$  to  $+5.2\text{ V}$ ,  $V_{EE} = -4.20\text{ V}$  to  $-5.5\text{ V}$ . Outputs are terminated through a  $50\ \Omega$  resistor to  $GND - 2.0\text{ V}$ .

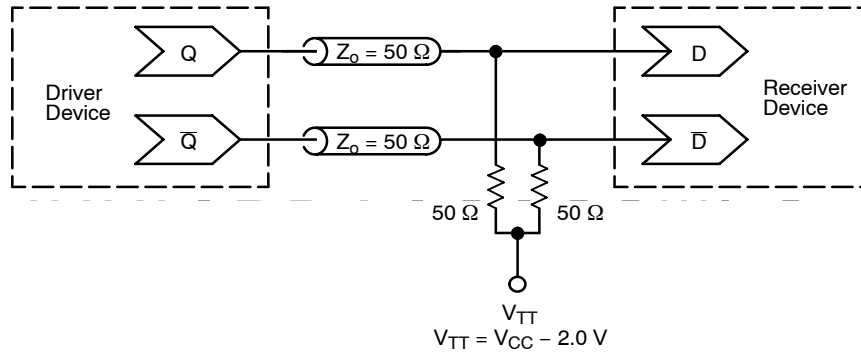

**Figure 2. Typical Termination for Output Driver and Device Evaluation**  
(See Application Note AND8020/D – Termination of ECL Logic Devices.)

# MC100EL91

## ORDERING INFORMATION

| Device         | Package               | Shipping†          |
|----------------|-----------------------|--------------------|
| MC100EL91DW    | SO-20 WB              | 38 Units / Rail    |
| MC100EL91DWG   | SO-20 WB<br>(Pb-Free) | 38 Units / Rail    |
| MC100EL91DWR2  | SO-20 WB              | 1000 / Tape & Reel |
| MC100EL91DWR2G | SO-20 WB<br>(Pb-Free) | 1000 / Tape & Reel |

†For information on tape and reel specifications, including part orientation and tape sizes, please refer to our Tape and Reel Packaging Specifications Brochure, BRD8011/D.

### Resource Reference of Application Notes

- AN1405/D** - ECL Clock Distribution Techniques
- AN1406/D** - Designing with PECL (ECL at +5.0 V)
- AN1503/D** - ECLinPS™ I/O SPICE Modeling Kit
- AN1504/D** - Metastability and the ECLinPS Family
- AN1568/D** - Interfacing Between LVDS and ECL
- AN1672/D** - The ECL Translator Guide
- AND8001/D** - Odd Number Counters Design
- AND8002/D** - Marking and Date Codes
- AND8020/D** - Termination of ECL Logic Devices
- AND8066/D** - Interfacing with ECLinPS
- AND8090/D** - AC Characteristics of ECL Devices

# MC100EL91

## PACKAGE DIMENSIONS

SO-20 WB  
DW SUFFIX  
CASE 751D-05  
ISSUE G

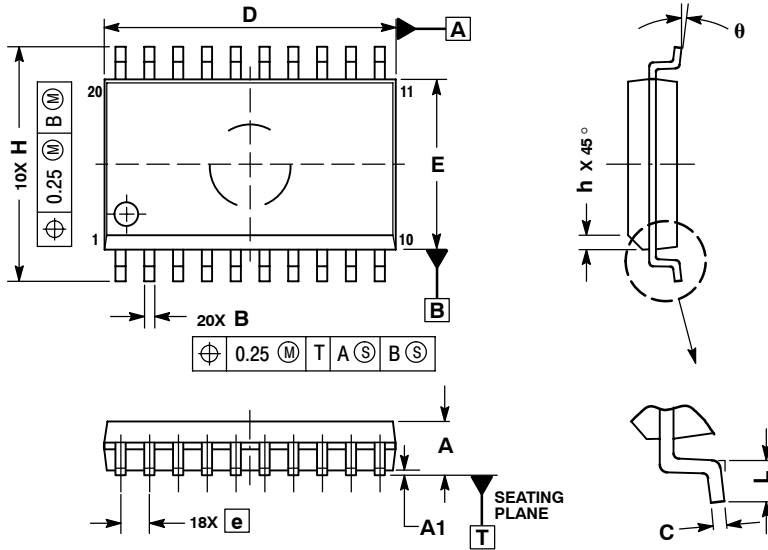

**NOTES:**

1. DIMENSIONS ARE IN MILLIMETERS.
2. INTERPRET DIMENSIONS AND TOLERANCES PER ASME Y14.5M, 1994.
3. DIMENSIONS D AND E DO NOT INCLUDE MOLD PROTRUSION.
4. MAXIMUM MOLD PROTRUSION 0.15 PER SIDE.
5. DIMENSION B DOES NOT INCLUDE DAMBAR PROTRUSION. ALLOWABLE PROTRUSION SHALL BE 0.13 TOTAL IN EXCESS OF B DIMENSION AT MAXIMUM MATERIAL CONDITION.

| DIM | MILLIMETERS |       |
|-----|-------------|-------|
|     | MIN         | MAX   |
| A   | 2.35        | 2.65  |
| A1  | 0.10        | 0.25  |
| B   | 0.35        | 0.49  |
| C   | 0.23        | 0.32  |
| D   | 12.65       | 12.95 |
| E   | 7.40        | 7.60  |
| e   | 1.27 BSC    |       |
| H   | 10.05       | 10.55 |
| h   | 0.25        | 0.75  |
| L   | 0.50        | 0.90  |
| θ   | 0°          | 7°    |

ECLinPS are registered trademarks of Semiconductor Components Industries, LLC (SCILLC).

**ON Semiconductor** and are registered trademarks of Semiconductor Components Industries, LLC (SCILLC). SCILLC reserves the right to make changes without further notice to any products herein. SCILLC makes no warranty, representation or guarantee regarding the suitability of its products for any particular purpose, nor does SCILLC assume any liability arising out of the application or use of any product or circuit, and specifically disclaims any and all liability, including without limitation special, consequential or incidental damages. "Typical" parameters which may be provided in SCILLC data sheets and/or specifications can and do vary in different applications and actual performance may vary over time. All operating parameters, including "Typicals" must be validated for each customer application by customer's technical experts. SCILLC does not convey any license under its patent rights nor the rights of others. SCILLC products are not designed, intended, or authorized for use as components in systems intended for surgical implant into the body, or other applications intended to support or sustain life, or for any other application in which the failure of the SCILLC product could create a situation where personal injury or death may occur. Should Buyer purchase or use SCILLC products for any such unintended or unauthorized application, Buyer shall indemnify and hold SCILLC and its officers, employees, subsidiaries, affiliates, and distributors harmless against all claims, costs, damages, and expenses, and reasonable attorney fees arising out of, directly or indirectly, any claim of personal injury or death associated with such unintended or unauthorized use, even if such claim alleges that SCILLC was negligent regarding the design or manufacture of the part. SCILLC is an Equal Opportunity/Affirmative Action Employer. This literature is subject to all applicable copyright laws and is not for resale in any manner.

### PUBLICATION ORDERING INFORMATION

**LITERATURE FULFILLMENT:**  
Literature Distribution Center for ON Semiconductor  
P.O. Box 61312, Phoenix, Arizona 85082-1312 USA  
**Phone:** 480-829-7710 or 800-344-3860 Toll Free USA/Canada  
**Fax:** 480-829-7709 or 800-344-3867 Toll Free USA/Canada  
**Email:** orderlit@onsemi.com

**N. American Technical Support:** 800-282-9855 Toll Free  
USA/Canada

**Japan:** ON Semiconductor, Japan Customer Focus Center  
2-9-1 Kamimeguro, Meguro-ku, Tokyo, Japan 153-0051  
**Phone:** 81-3-5773-3850

**ON Semiconductor Website:** <http://onsemi.com>

**Order Literature:** <http://www.onsemi.com/litorder>

For additional information, please contact your local Sales Representative.

[www.BDTIC.com/ON/](http://www.BDTIC.com/ON/)

MC100EL91/D