

MC100EP91

2.5 V/3.3 V Any Level Positive Input to -3.3 V/-5.5 V NECL Output Translator

Description

The MC100EP91 is a triple any level positive input to NECL output translator. The device accepts LVPECL, LVTTTL, LVCMOS, HSTL, CML or LVDS signals, and translates them to differential NECL output signals ($-3.0\text{ V} / -5.5\text{ V}$).

To accomplish the level translation the EP91 requires three power rails. The V_{CC} pins should be connected to the positive power supply, and the V_{EE} pin should be connected to the negative power supply. The GND pins are connected to the system ground plane. Both V_{EE} and V_{CC} should be bypassed to ground via $0.01\text{ }\mu\text{F}$ capacitors.

Under open input conditions, the \bar{D} input will be biased at $V_{CC}/2$ and the D input will be pulled to GND. These conditions will force the Q outputs to a low state, and Q outputs to a high state, which will ensure stability.

The V_{BB} pin, an internally generated voltage supply, is available to this device only. For single-ended input conditions, the unused differential input is connected to V_{BB} as a switching reference voltage. V_{BB} may also rebias AC coupled inputs. When used, decouple V_{BB} and V_{CC} via a $0.01\text{ }\mu\text{F}$ capacitor and limit current sourcing or sinking to 0.5 mA . When not used, V_{BB} should be left open.

Features

- Maximum Input Clock Frequency > 2.0 GHz Typical
- Maximum Input Data Rate > 2.0 Gb/s Typical
- 500 ps Typical Propagation Delay
- Operating Range: $V_{CC} = 2.375\text{ V}$ to 3.8 V ;
 $V_{EE} = -3.0\text{ V}$ to -5.5 V ; $GND = 0\text{ V}$
- Q Output will Default LOW with Inputs Open or at GND
- Pb-Free Packages are Available*



ON Semiconductor®

<http://onsemi.com>

MARKING DIAGRAMS*

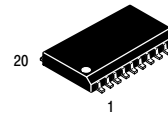

SO-20 WB
DW SUFFIX
CASE 751D

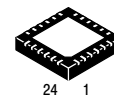
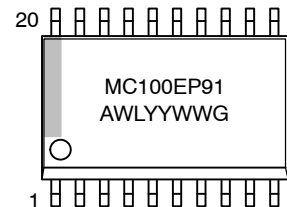

24 PIN QFN
MN SUFFIX
CASE 485L

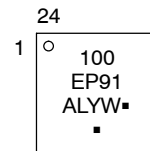

A = Assembly Location
WL, L = Wafer Lot
YY, Y = Year
WW, W = Work Week
G or ■ = Pb-Free Package

(Note: Microdot may be in either location)

*For additional marking information, refer to Application Note AND8002/D.

ORDERING INFORMATION

See detailed ordering and shipping information in the package dimensions section on page 8 of this data sheet.

*For additional information on our Pb-Free strategy and soldering details, please download the ON Semiconductor Soldering and Mounting Techniques Reference Manual, SOLDERRM/D.

MC100EP91

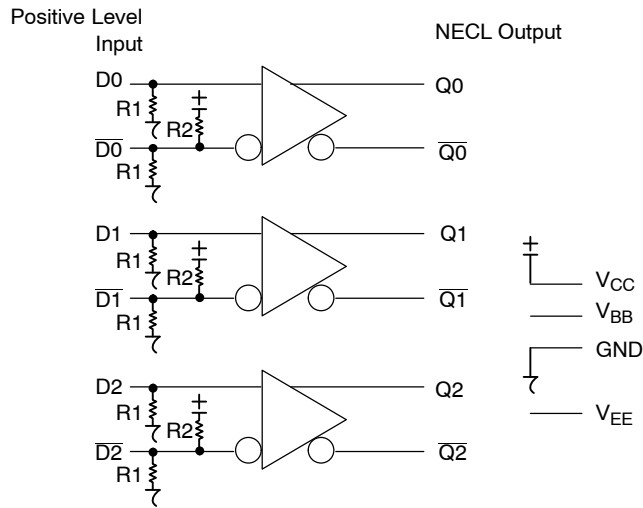

Figure 1. Logic Diagram

Table 1. PIN DESCRIPTION

Pin		Name	I/O	Default State	Description
SOIC	QFN				
1, 20	3, 4, 12	V _{CC}	-	-	Positive Supply Voltage. All V _{CC} Pins must be Externally Connected to Power Supply to Guarantee Proper Operation.
10	15, 16	V _{EE}	-	-	Negative Supply Voltage. All V _{EE} Pins must be Externally Connected to Power Supply to Guarantee Proper Operation.
14, 17	19, 20, 23, 24	GND	-	-	Ground.
4, 7	7, 11	V _{BB}	-	-	ECL Reference Voltage Output
2, 5, 8	5, 8, 13	D[0:2]	LVPECL, LVDS, LVTTTL, LVCMOS, CML, HSTL Input	Low	Noninverted Differential Inputs [0:2]. Internal 75 kΩ to V _{EE} .
3, 6, 9	6, 9, 14	\overline{D} [0:2]	LVPECL, LVDS, LVTTTL, LVCMOS, CML, HSTL Input	High	Inverted Differential Inputs [0:2]. Internal 75 kΩ to GND and 75 kΩ to V _{CC} . When Inputs are Left Open They Default to (V _{CC} - GND) / 2.
19,16,13	2, 18, 22	Q[0:2]	NECL Output	-	Noninverted Differential Outputs [0:2]. Typically Terminated with 50 Ω to V _{TT} = V _{CC} - 2 V
18,15,12	1, 21, 17	\overline{Q} [0:2]	NECL Output	-	Inverted Differential Outputs [0:2]. Typically Terminated with 50 Ω to V _{TT} = V _{CC} - 2 V
11	10	NC	-	-	No Connect. The NC Pin is NOT Electrically Connected to the Die and may Safely be Connected to Any Voltage from V _{EE} to V _{CC} .
N/A	-	EP	-	-	Exposed Pad. (Note 1)

1. The thermally conductive exposed pad on the package bottom (see case drawing) must be attached to a heat-sinking conduit and may only be electrically connected to V_{EE} (not GND).

MC100EP91

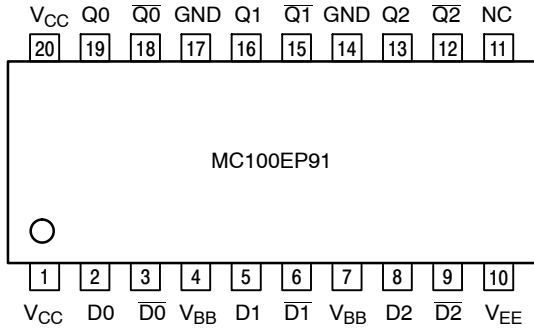

Figure 2. SOIC-20 Lead Pinout (Top View)

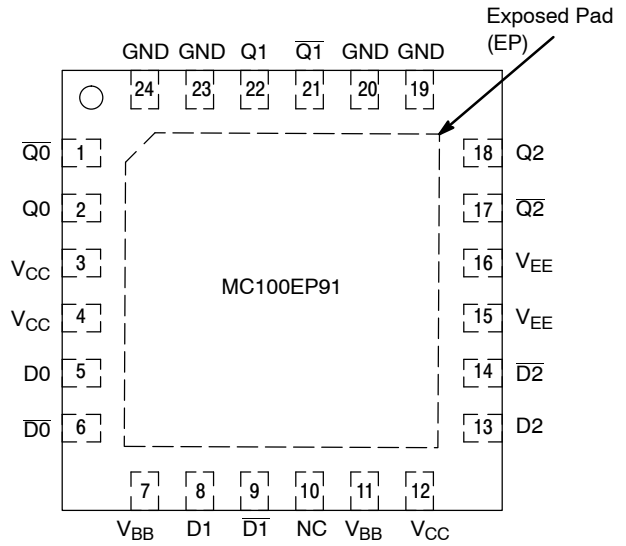

Figure 3. QFN-24 Lead Pinout (Top View)*

*All V_{CC}, V_{EE} and GND pins must be externally connected to a power supply and the underside exposed pad must be attached to an adequate heat-sinking conduit to guarantee proper operation.

Table 2. ATTRIBUTES

Characteristics		Value	
Internal Input Pulldown Resistor	(R1)	75 kΩ	
Internal Input Pullup Resistor	(R2)	75 kΩ	
ESD Protection	Human Body Model Machine Model Charged Device Model	> 2 kV > 150 V > 2 kV	
Moisture Sensitivity (Note 2)	— — — — —	Pb Pkg	Pb-Free Pkg
	SO-20 WB QFN-24	Level 1 Level 1	Level 3 Level 1
Flammability Rating	Oxygen Index: 28 to 34	UL 94 V-0 @ 0.125 in	
Transistor Count		446 Devices	
Meets or exceeds JEDEC Spec EIA/JESD78 IC Latchup Test			

2. For additional information, see Application Note AND8003/D.

MC100EP91

Table 3. MAXIMUM RATINGS

Symbol	Parameter	Condition 1	Condition 2	Rating	Unit
V _{CC}	Positive Power Supply	GND = 0 V		3.8 to 0	V
V _{EE}	Negative Power Supply	GND = 0 V		-6	V
V _I	Positive Input Voltage	GND = 0 V	V _I ≤ V _{CC}	3.8 to 0	V
V _{OP}	Operating Voltage	GND = 0 V	V _{CC} - V _{EE}	9.8	V
I _{out}	Output Current	Continuous Surge		50 100	mA mA
I _{BB}	PECL V _{BB} Sink/Source			± 0.5	mA
T _A	Operating Temperature Range			-40 to +85	°C
T _{stg}	Storage Temperature Range			-65 to +150	°C
θ _{JA}	Thermal Resistance (Junction-to-Ambient) JESD 51-3 (1S-Single Layer Test Board)	0 lfpm 500 lfpm	SOIC-20 SOIC-20	90 60	°C/W °C/W
θ _{JA}	Thermal Resistance (Junction-to-Ambient) JESD 51-6 (2S2P Multilayer Test Board) with Filled Thermal Vias	0 lfpm 500 lfpm	QFN-24 QFN-24	37 32	°C/W °C/W
θ _{JC}	Thermal Resistance (Junction-to-Case)	Standard Board	SOIC-20 QFN-24	30 to 35 11	°C/W °C/W
T _{sol}	Wave Solder	Pb Pb-Free		225 225	°C

Stresses exceeding Maximum Ratings may damage the device. Maximum Ratings are stress ratings only. Functional operation above the Recommended Operating Conditions is not implied. Extended exposure to stresses above the Recommended Operating Conditions may affect device reliability.

Table 4. DC CHARACTERISTICS POSITIVE INPUTS V_{CC} = 2.5 V, V_{EE} = -3.0 V to -5.5 V, GND = 0 V (Note 3)

Symbol	Characteristic	-40°C			25°C			85°C			Unit
		Min	Typ	Max	Min	Typ	Max	Min	Typ	Max	
I _{CC}	Positive Power Supply Current	10	14	20	10	14	20	10	14	20	mA
V _{IH}	Input HIGH Voltage (Single-Ended)	1335		V _{CC}	1335		V _{CC}	1335		V _{CC}	mV
V _{IL}	Input LOW Voltage (Single-Ended)	GND		875	GND		875	GND		875	mV
V _{IHCMR}	Input HIGH Voltage Common Mode Range (Differential Configuration) (Note 4)	0		2.5	0		2.5	0		2.5	V
I _{IH}	Input HIGH Current (@ V _{IH})			150			150			150	μA
I _{IL}	Input LOW Current (@ V _{IL})	D D	0.5 -150		0.5 -150			0.5 -150			μA

NOTE: Device will meet the specifications after thermal equilibrium has been established when mounted in a test socket or printed circuit board with maintained transverse airflow greater than 500 lfpm. Electrical parameters are guaranteed only over the declared operating temperature range. Functional operation of the device exceeding these conditions is not implied. Device specification limit values are applied individually under normal operating conditions and not valid simultaneously.

- Input parameters vary 1:1 with V_{CC}. V_{CC} can vary +1.3 V / -0.125 V.
- V_{IHCMR} min varies 1:1 with GND. V_{IHCMR} max varies 1:1 with V_{CC}.

MC100EP91

Table 5. DC CHARACTERISTICS POSITIVE INPUT $V_{CC} = 3.3\text{ V}$; $V_{EE} = -3.0\text{ V}$ to -5.5 V ; $GND = 0\text{ V}$ (Note 5)

Symbol	Characteristic	-40°C			25°C			85°C			Unit
		Min	Typ	Max	Min	Typ	Max	Min	Typ	Max	
I_{CC}	Positive Power Supply Current	10	16	24	10	16	24	10	16	24	mA
V_{IH}	Input HIGH Voltage (Single-Ended)	2135		V_{CC}	2135		V_{CC}	2135		V_{CC}	mV
V_{IL}	Input LOW Voltage (Single-Ended)	GND		1675	GND		1675	GND		1675	mV
V_{BB}	PECL Output Voltage Reference	1775	1875	1975	1775	1875	1975	1775	1875	1975	mV
V_{IHCMR}	Input HIGH Voltage Common Mode Range (Differential Configuration) (Note 6)	0		3.3	0		3.3	0		3.3	V
I_{IH}	Input HIGH Current (@ V_{IH})			150			150			150	μA
I_{IL}	Input LOW Current (@ V_{IL})	$\frac{D}{D}$ 0.5 -150			0.5 -150			0.5 -150			μA

NOTE: Device will meet the specifications after thermal equilibrium has been established when mounted in a test socket or printed circuit board with maintained transverse airflow greater than 500 lfm. Electrical parameters are guaranteed only over the declared operating temperature range. Functional operation of the device exceeding these conditions is not implied. Device specification limit values are applied individually under normal operating conditions and not valid simultaneously.

5. Input parameters vary 1:1 with V_{CC} . V_{CC} can vary +0.5 / -0.925 V.
 6. V_{IHCMR} min varies 1:1 with GND. V_{IHCMR} max varies 1:1 with V_{CC} .

Table 6. DC CHARACTERISTICS NECL OUTPUT $V_{CC} = 2.375\text{ V}$ to 3.8 V ; $V_{EE} = -3.0\text{ V}$ to -5.5 V ; $GND = 0\text{ V}$ (Note 7)

Symbol	Characteristic	-40°C			25°C			85°C			Unit
		Min	Typ	Max	Min	Typ	Max	Min	Typ	Max	
I_{EE}	Negative Power Supply Current	40	50	60	38	50	68	38	50	68	mA
V_{OH}	Output HIGH Voltage (Note 8)	-1145	-1020	-895	-1145	-1020	-895	-1145	-1020	-895	mV
V_{OL}	Output LOW Voltage (Note 8)	-1945	-1770	-1600	-1945	-1770	-1600	-1945	-1770	-1600	mV

NOTE: Device will meet the specifications after thermal equilibrium has been established when mounted in a test socket or printed circuit board with maintained transverse airflow greater than 500 lfm. Electrical parameters are guaranteed only over the declared operating temperature range. Functional operation of the device exceeding these conditions is not implied. Device specification limit values are applied individually under normal operating conditions and not valid simultaneously.

7. Output parameters vary 1:1 with GND.
 8. All loading with 50 Ω resistor to GND - 2.0 V.

MC100EP91

Table 7. AC CHARACTERISTICS $V_{CC} = 2.375\text{ V to }3.8\text{ V}$; $V_{EE} = -3.0\text{ V to }-5.5\text{ V}$; $GND = 0\text{ V}$

Symbol	Characteristic	-40°C			25°C			85°C			Unit
		Min	Typ	Max	Min	Typ	Max	Min	Typ	Max	
V_{OUTPP}	Output Voltage Amplitude (Figure 4) (Note 9)	$f_{in} \leq 1.0\text{ GHz}$ 575	$f_{in} \leq 1.5\text{ GHz}$ 800	$f_{in} \leq 2.0\text{ GHz}$ 600	$f_{in} \leq 1.0\text{ GHz}$ 600	$f_{in} \leq 1.5\text{ GHz}$ 800	$f_{in} \leq 2.0\text{ GHz}$ 250	$f_{in} \leq 1.0\text{ GHz}$ 550	$f_{in} \leq 1.5\text{ GHz}$ 400	$f_{in} \leq 2.0\text{ GHz}$ 150	mV
t_{PLH} t_{PHL}	Propagation Delay D to Q Differential Single-Ended	375 300	500 450	600 650	375 300	500 450	600 675	400 300	550 500	650 750	ps
t_{SKEW}	Pulse Skew (Note 10) Output-to-Output (Note 11) Part-to-Part (Diff) (Note 11)		15 25 50	75 95 125		15 30 50	75 105 125		15 30 70	80 105 150	ps
t_{JITTER}	RMS Random Clock Jitter (Note 12) Peak-to-Peak Data Dependant Jitter (Note 13)		0.5 20	2.0		0.5 20	2.0		0.5 20	2.0	ps
V_{INPP}	Input Voltage Swing (Differential Configuration) (Note 14)	200	800	1200	200	800	1200	200	800	1200	mV
t_r, t_f	Output Rise/Fall Times @ 50 MHz (20% - 80%) Q, \bar{Q}	75	150	250	75	150	250	75	150	275	ps

NOTE: Device will meet the specifications after thermal equilibrium has been established when mounted in a test socket or printed circuit board with maintained transverse airflow greater than 500 lpm. Electrical parameters are guaranteed only over the declared operating temperature range. Functional operation of the device exceeding these conditions is not implied. Device specification limit values are applied individually under normal operating conditions and not valid simultaneously.

9. Measured using a 750 mV source, 50% duty cycle clock source. All loading with 50 Ω to GND - 2.0 V. Input edge rates 150 ps (20% - 80%).
10. Pulse Skew = $|t_{PLH} - t_{PHL}|$
11. Skews are valid across specified voltage range, part-to-part skew is for a given temperature.
12. RMS Jitter with 50% Duty Cycle Input Clock Signal.
13. Peak-to-Peak Jitter with input NRZ PRBS $2^{31}-1$ at 2.0 Gb/s.
14. Input voltage swing is a single-ended measurement operating in differential mode. The device has a DC gain of ≈ 50 .

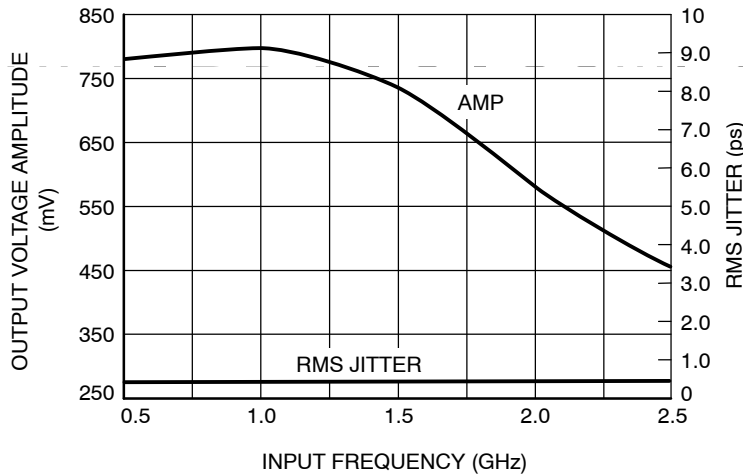

Figure 4. Output Voltage Amplitude (V_{OUTPP}) / RMS Jitter vs. Input Frequency (f_{in}) at Ambient Temperature (Typical)

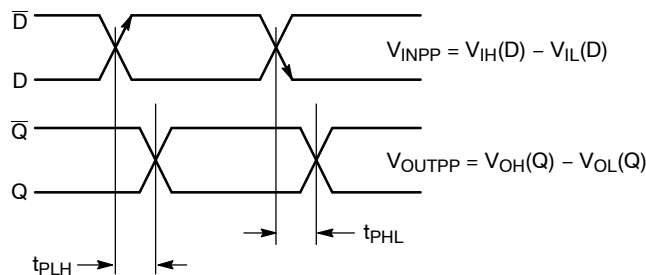

Figure 5. AC Reference Measurement

MC100EP91

Application Information

All MC100EP91 inputs can accept LVPECL, LVTTTL, LVCMOS, HSTL, CML, or LVDS signal levels. The limitations for differential input signal (LVDS, HSTL, LVPECL, or CML) are the minimum input swing of 150 mV

and the maximum input swing of 3.0 V. Within these conditions, the input voltage can range from V_{CC} to GND. Examples interfaces are illustrated below in a 50 Ω environment ($Z = 50 \Omega$)

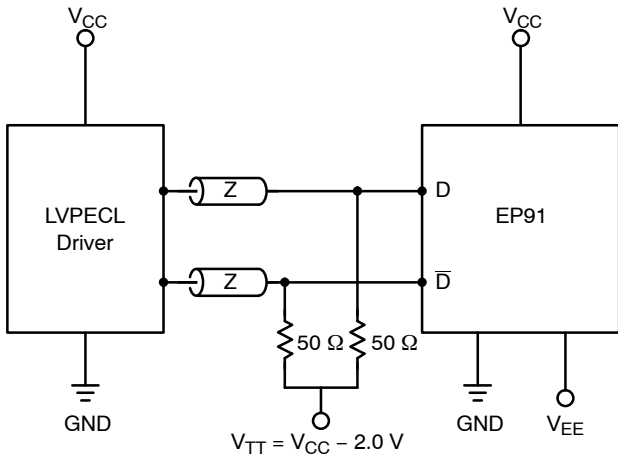

Figure 6. Standard LVPECL Interface

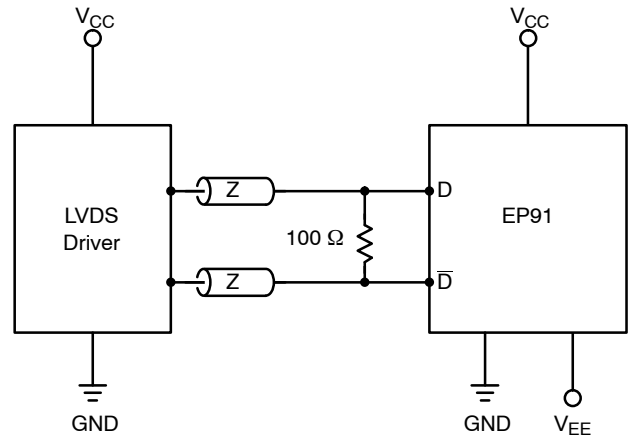

Figure 7. Standard LVDS Interface

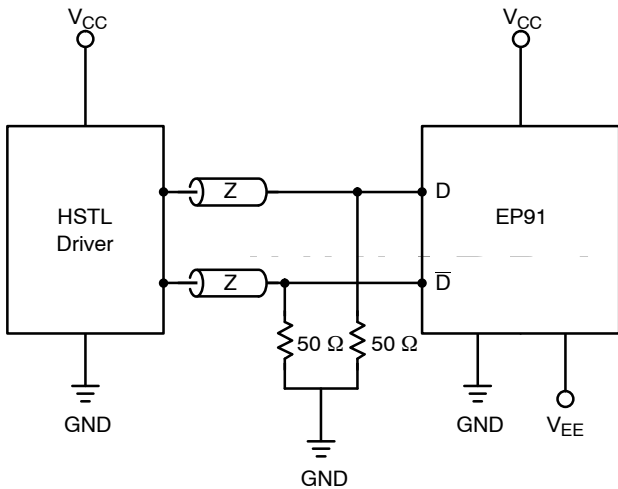

Figure 8. Standard HSTL Interface

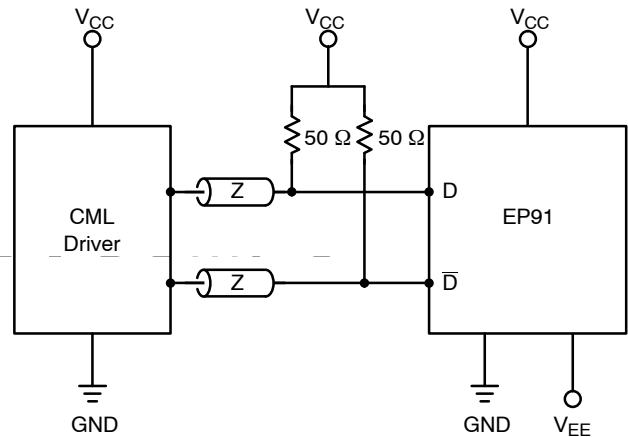

Figure 9. Standard 50 Ω Load CML Interface

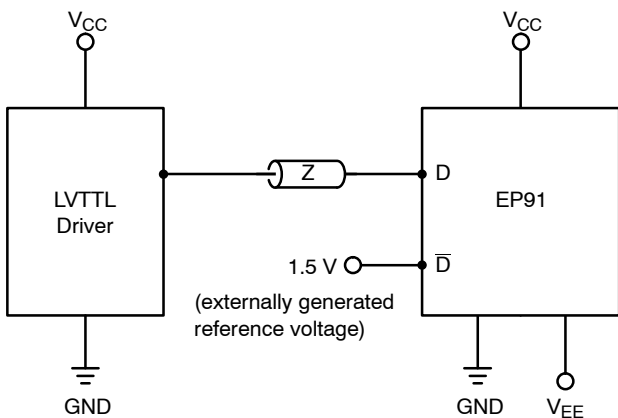

Figure 10. Standard LVTTTL Interface

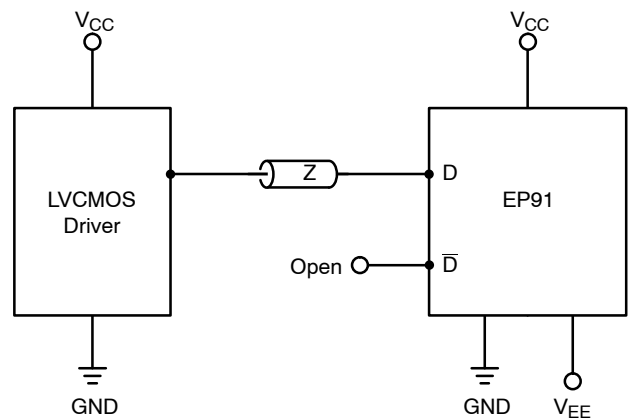

Figure 11. Standard LVCMOS Interface
(\bar{D} will default to $V_{CC}/2$ when left open.
A reference voltage of $V_{CC}/2$ should be applied to \bar{D} input, if \bar{D} is interfaced to CMOS signals.)

MC100EP91

ORDERING INFORMATION

Device	Package	Shipping [†]
MC100EP91DW	SO-20	38 Units / Rail
MC100EP91DWG	SO-20 (Pb-Free)	38 Units / Rail
MC100EP91DWR2	SO-20	1000 / Tape & Reel
MC100EP91DWR2G	SO-20 (Pb-Free)	1000 / Tape & Reel
MC100EP91MN	QFN-24	92 Units / Rail
MC100EP91MNG	QFN-24 (Pb-Free)	92 Units / Rail
MC100EP91MNR2	QFN-24	3000 / Tape & Reel
MC100EP91MNR2G	QFN-24 (Pb-Free)	3000 / Tape & Reel

[†]For information on tape and reel specifications, including part orientation and tape sizes, please refer to our Tape and Reel Packaging Specifications Brochure, BRD8011/D.

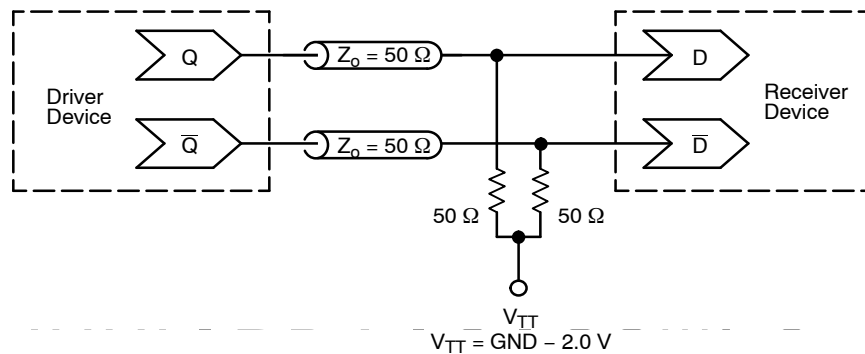

**Figure 12. Typical Termination for Output Driver and Device Evaluation
(See Application Note AND8020/D – Termination of ECL Logic Devices.)**

Resource Reference of Application Notes

- AN1405/D** – ECL Clock Distribution Techniques
- AN1406/D** – Designing with PECL (ECL at +5.0 V)
- AN1503/D** – ECLinPS™ I/O SPICE Modeling Kit
- AN1504/D** – Metastability and the ECLinPS Family
- AN1568/D** – Interfacing Between LVDS and ECL
- AN1672/D** – The ECL Translator Guide
- AND8001/D** – Odd Number Counters Design
- AND8002/D** – Marking and Date Codes
- AND8020/D** – Termination of ECL Logic Devices
- AND8066/D** – Interfacing with ECLinPS
- AND8090/D** – AC Characteristics of ECL Devices

MC100EP91

PACKAGE DIMENSIONS

SO-20 WB
CASE 751D-05
ISSUE G

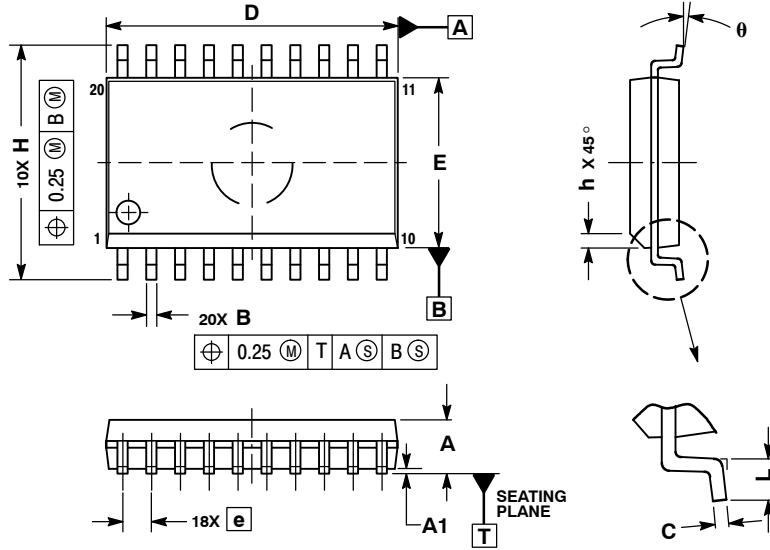

- NOTES:
1. DIMENSIONS ARE IN MILLIMETERS.
 2. INTERPRET DIMENSIONS AND TOLERANCES PER ASME Y14.5M, 1994.
 3. DIMENSIONS D AND E DO NOT INCLUDE MOLD PROTRUSION.
 4. MAXIMUM MOLD PROTRUSION 0.15 PER SIDE.
 5. DIMENSION B DOES NOT INCLUDE DAMBAR PROTRUSION. ALLOWABLE PROTRUSION SHALL BE 0.13 TOTAL IN EXCESS OF B DIMENSION AT MAXIMUM MATERIAL CONDITION.

DIM	MILLIMETERS	
	MIN	MAX
A	2.35	2.65
A1	0.10	0.25
B	0.35	0.49
C	0.23	0.32
D	12.65	12.95
E	7.40	7.60
e	1.27 BSC	
H	10.05	10.55
h	0.25	0.75
L	0.50	0.90
θ	0°	7°

MC100EP91

PACKAGE DIMENSIONS

QFN 24
MN SUFFIX
 24 PIN QFN, 4x4
 CASE 485L-01
 ISSUE O

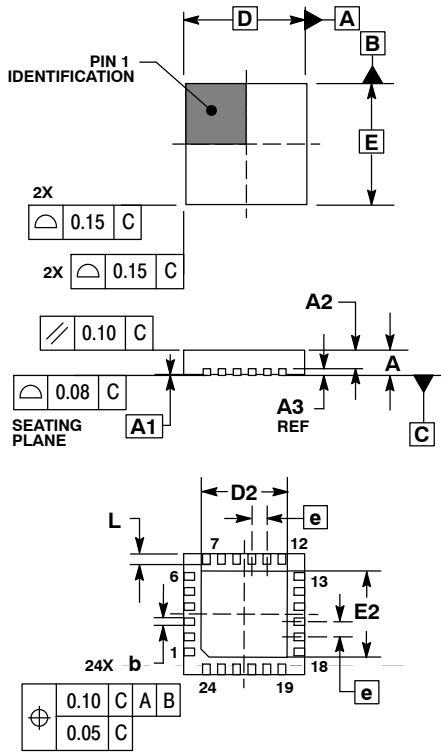

NOTES:

1. DIMENSIONING AND TOLERANCING PER ASME Y14.5M, 1994.
2. CONTROLLING DIMENSION: MILLIMETERS.
3. DIMENSION b APPLIES TO PLATED TERMINAL AND IS MEASURED BETWEEN 0.25 AND 0.30 MM FROM TERMINAL.
4. COPLANARITY APPLIES TO THE EXPOSED PAD AS WELL AS THE TERMINALS.

DIM	MILLIMETERS	
	MIN	MAX
A	0.80	1.00
A1	0.00	0.05
A2	0.60	0.80
A3	0.20	REF
b	0.23	0.28
D	4.00	BSC
D2	2.70	2.90
E	4.00	BSC
E2	2.70	2.90
e	0.50	BSC
L	0.35	0.45

ECLinPS is a trademark of Semiconductor Components Industries, LLC.

ON Semiconductor and **ON** are registered trademarks of Semiconductor Components Industries, LLC (SCILLC). SCILLC reserves the right to make changes without further notice to any products herein. SCILLC makes no warranty, representation or guarantee regarding the suitability of its products for any particular purpose, nor does SCILLC assume any liability arising out of the application or use of any product or circuit, and specifically disclaims any and all liability, including without limitation special, consequential or incidental damages. "Typical" parameters which may be provided in SCILLC data sheets and/or specifications can and do vary in different applications and actual performance may vary over time. All operating parameters, including "Typicals" must be validated for each customer application by customer's technical experts. SCILLC does not convey any license under its patent rights nor the rights of others. SCILLC products are not designed, intended, or authorized for use as components in systems intended for surgical implant into the body, or other applications intended to support or sustain life, or for any other application in which the failure of the SCILLC product could create a situation where personal injury or death may occur. Should Buyer purchase or use SCILLC products for any such unintended or unauthorized application, Buyer shall indemnify and hold SCILLC and its officers, employees, subsidiaries, affiliates, and distributors harmless against all claims, costs, damages, and expenses, and reasonable attorney fees arising out of, directly or indirectly, any claim of personal injury or death associated with such unintended or unauthorized use, even if such claim alleges that SCILLC was negligent regarding the design or manufacture of the part. SCILLC is an Equal Opportunity/Affirmative Action Employer. This literature is subject to all applicable copyright laws and is not for resale in any manner.

PUBLICATION ORDERING INFORMATION

LITERATURE FULFILLMENT:
 Literature Distribution Center for ON Semiconductor
 P.O. Box 5163, Denver, Colorado 80217 USA
Phone: 303-675-2175 or 800-344-3860 Toll Free USA/Canada
Fax: 303-675-2176 or 800-344-3867 Toll Free USA/Canada
Email: orderlit@onsemi.com

N. American Technical Support: 800-282-9855 Toll Free
 USA/Canada
Europe, Middle East and Africa Technical Support:
 Phone: 421 33 790 2910
Japan Customer Focus Center
 Phone: 81-3-5773-3850

ON Semiconductor Website: www.onsemi.com
Order Literature: <http://www.onsemi.com/orderlit>

For additional information, please contact your local Sales Representative