

# MC100LVEP210

## 2.5V / 3.3V 1:5 Dual Differential ECL/PECL/HSTL Clock Driver

### Description

The MC100LVEP210 is a low skew 1-to-5 dual differential driver, designed with clock distribution in mind. The ECL/PECL input signals can be either differential or single-ended if the  $V_{BB}$  output is used. The signal is fanned out to 5 identical differential outputs. HSTL inputs can be used when the EP210 is operating in PECL mode.

The LVEP210 specifically guarantees low output-to-output skew. Optimal design, layout, and processing minimize skew within a device and from device to device.

To ensure the tight skew specification is realized, both sides of the differential output need to be terminated identically into  $50\ \Omega$  even if only one output is being used. If an output pair is unused, both outputs may be left open (unterminated) without affecting skew.

The MC100LVEP210, as with most other ECL devices, can be operated from a positive  $V_{CC}$  supply in PECL mode. This allows the LVEP210 to be used for high performance clock distribution in +3.3 V or +2.5 V systems. Single-ended CLK input operation is limited to a  $V_{CC} \geq 3.0\ \text{V}$  in PECL mode, or  $V_{EE} \leq -3.0\ \text{V}$  in ECL mode.

Designers can take advantage of the LVEP210's performance to distribute low skew clocks across the package and the board. In a PECL environment, series or Thevenin line terminations are typically used as they require no additional power supplies. For more information on using PECL, designers should refer to Application Note AN1406/D.

### Features

- 85 ps Typical Device-to- Device Skew
- 20 ps Typical Output-to-Output Skew
- $V_{BB}$  Output
- Jitter Less than 1 ps RMS
- 350 ps Typical Propagation Delay
- Maximum Frequency > 3 GHz Typical
- The 100 Series Contains Temperature Compensation
- PECL and HSTL Mode Operating Range:  $V_{CC} = 2.375\ \text{V}$  to  $3.8\ \text{V}$  with  $V_{EE} = 0\ \text{V}$
- NECL Mode Operating Range:  $V_{CC} = 0\ \text{V}$  with  $V_{EE} = -2.375\ \text{V}$  to  $-3.8\ \text{V}$
- Open Input Default State
- LVDS Input Compatible
- Fully Compatible with MC100EP210
- Pb-Free Packages are Available\*

\*For additional information on our Pb-Free strategy and soldering details, please download the ON Semiconductor Soldering and Mounting Techniques Reference Manual, SOLDERRM/D.



ON Semiconductor®

<http://onsemi.com>

### MARKING DIAGRAMS\*

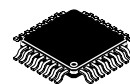

32-LEAD LQFP  
FA SUFFIX  
CASE 873A

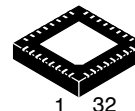
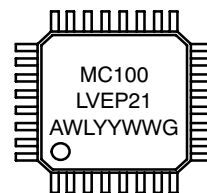

QFN32  
MN SUFFIX  
CASE 488AM

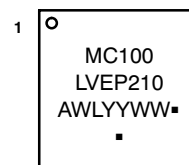

A = Assembly Location  
WL = Wafer Lot  
YY = Year  
WW = Work Week  
G or ■ = Pb-Free Package  
(Note: Microdot may be in either location)

\*For additional marking information, refer to Application Note AND8002/D.

### ORDERING INFORMATION

See detailed ordering and shipping information in the package dimensions section on page 7 of this data sheet.

# MC100LVEP210

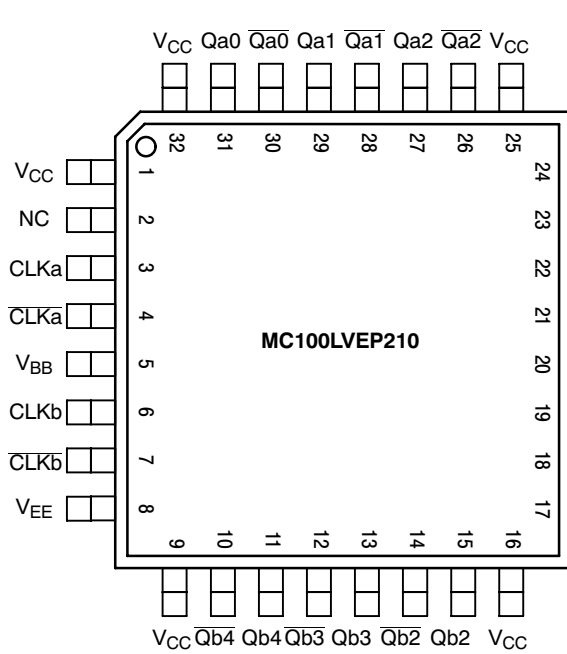

Warning: All  $V_{CC}$  and  $V_{EE}$  pins must be externally connected to Power Supply to guarantee proper operation.

Figure 1. 32-Lead QFN Pinout (Top View)

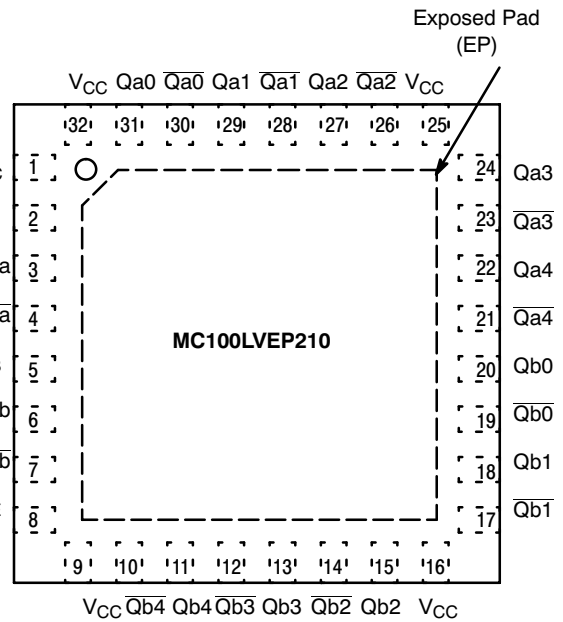

Figure 2. LQFP-32 Pinout (Top View)

Table 1. PIN DESCRIPTION

PIN	FUNCTION
CLKn*, CLKn**	ECL/PECL/HSTL CLK inputs
Qn0:4, Qn0:4-bar	ECL/PECL Outputs
$V_{BB}$	Reference Voltage Output
$V_{CC}$	Positive Supply
$V_{EE}$	Negative Supply
EP	The exposed pad (EP) on the QFN-32 package bottom is thermally connected to the die for improved heat transfer out of the package. The exposed pad must be attached to a heat-sinking conduit. The pad is electrically connected to $V_{EE}$ .

\* Pins will default LOW when left open.

\*\* Pins will default to  $V_{CC}/2$  when left open.

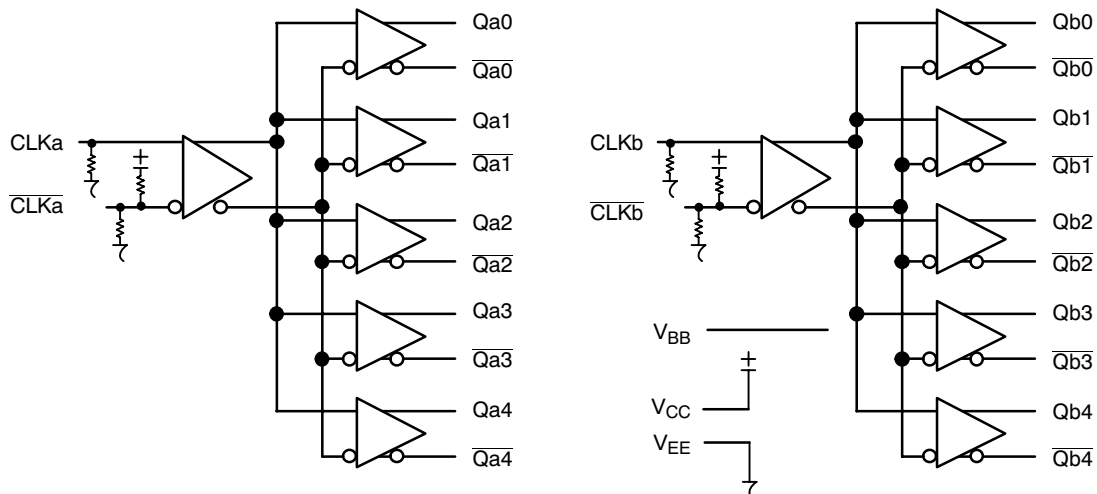

Figure 3. Logic Diagram

# MC100LVEP210

**Table 2. ATTRIBUTES**

Characteristics		Value	
Internal Input Pulldown Resistor		75 k $\Omega$	
Internal Input Pull-up Resistor		37.5 k $\Omega$	
ESD Protection	Human Body Model Machine Model Charged Device Model	> 2 kV > 100 V > 2 kV	
Moisture Sensitivity (Note 1)		Pb Pkg	Pb-Free Pkg
		LQFP-32 QFN-32	Level 2 N/A Level 2 Level 1
Flammability Rating	Oxygen Index: 28 to 34	UL 94 V-0 @ 0.125 in	
Transistor Count		461 Devices	
Meets or exceeds JEDEC Spec EIA/JESD78 IC Latchup Test			

1. For additional information, see Application Note AND8003/D.

**Table 3. MAXIMUM RATINGS**

Symbol	Parameter	Condition 1	Condition 2	Rating	Unit
V <sub>CC</sub>	PECL Mode Power Supply	V <sub>EE</sub> = 0 V		6	V
V <sub>EE</sub>	NECL Mode Power Supply	V <sub>CC</sub> = 0 V		-6	V
V <sub>I</sub>	PECL Mode Input Voltage	V <sub>EE</sub> = 0 V	V <sub>I</sub> ≤ V <sub>CC</sub>	6	V
	NECL Mode Input Voltage	V <sub>CC</sub> = 0 V	V <sub>I</sub> ≥ V <sub>EE</sub>	-6	V
I <sub>out</sub>	Output Current	Continuous Surge		50	mA
				100	mA
I <sub>BB</sub>	V <sub>BB</sub> Sink Source			±0.5	mA
T <sub>A</sub>	Operating Temperature Range			-40 to +85	°C
T <sub>stg</sub>	Storage Temperature Range			-65 to +150	°C
$\theta_{JA}$	Thermal Resistance (Junction-to-Ambient)	0 lfpm	LQFP-32	80	°C/W
		500 lfpm	LQFP-32	55	°C/W
$\theta_{JC}$	Thermal Resistance (Junction-to-Case)	Standard Board	LQFP-32	12 to 17	°C/W
$\theta_{JA}$	Thermal Resistance (Junction-to-Ambient)	0 lfpm	QFN-32	31	°C/W
		500 lfpm	QFN-32	27	°C/W
$\theta_{JC}$	Thermal Resistance (Junction-to-Case)	2S2P	QFN-32	12	°C/W
T <sub>sol</sub>	Wave Solder	Pb		265	°C
		Pb-Free	<2 to 3 sec @ 248°C <2 to 3 sec @ 260°C	265	°C

Stresses exceeding Maximum Ratings may damage the device. Maximum Ratings are stress ratings only. Functional operation above the Recommended Operating Conditions is not implied. Extended exposure to stresses above the Recommended Operating Conditions may affect device reliability.

# MC100LVEP210

**Table 4. PECL DC CHARACTERISTICS**  $V_{CC} = 2.5\text{ V}$ ;  $V_{EE} = 0\text{ V}$  (Note 2)

Symbol	Characteristic	-40 °C			25 °C			85 °C			Unit
		Min	Typ	Max	Min	Typ	Max	Min	Typ	Max	
$I_{EE}$	Power Supply Current	55	70	90	55	70	90	55	70	90	mA
$V_{OH}$	Output HIGH Voltage (Note 3)	1355	1480	1605	1355	1480	1605	1355	1480	1605	mV
$V_{OL}$	Output LOW Voltage (Note 3)	555	680	900	555	680	900	555	680	900	mV
$V_{IHCMR}$	Input HIGH Voltage Common Mode Range (Differential Configuration) (Note 4)	1.2		2.5	1.2		2.5	1.2		2.5	V
$V_{IL}$	Input LOW Voltage (Single-Ended)	555		900	555		900	555		900	mV
$I_{IH}$	Input HIGH Current			150			150			150	$\mu\text{A}$
$I_{IL}$	Input LOW Current		CLK CLK	0.5 -150			0.5 -150			0.5 -150	$\mu\text{A}$

NOTE: Device will meet the specifications after thermal equilibrium has been established when mounted in a test socket or printed circuit board with maintained transverse airflow greater than 500 lfm. Electrical parameters are guaranteed only over the declared operating temperature range. Functional operation of the device exceeding these conditions is not implied. Device specification limit values are applied individually under normal operating conditions and not valid simultaneously.

2. Input and output parameters vary 1:1 with  $V_{CC}$ .  $V_{EE}$  can vary + 0.125 V to -1.3 V.

3. All loading with 50  $\Omega$  to  $V_{EE}$ .

4.  $V_{IHCMR}$  min varies 1:1 with  $V_{EE}$ ;  $V_{IHCMR}$  max varies 1:1 with  $V_{CC}$ . The  $V_{IHCMR}$  range is referenced to the most positive side of the differential input signal.

**Table 5. PECL DC CHARACTERISTICS**  $V_{CC} = 3.3\text{ V}$ ;  $V_{EE} = 0\text{ V}$  (Note 5)

Symbol	Characteristic	-40 °C			25 °C			85 °C			Unit
		Min	Typ	Max	Min	Typ	Max	Min	Typ	Max	
$I_{EE}$	Power Supply Current	55	70	90	55	70	90	55	70	90	mA
$V_{OH}$	Output HIGH Voltage (Note 6)	2155	2280	2405	2155	2280	2405	2155	2280	2405	mV
$V_{OL}$	Output LOW Voltage (Note 6)	1355	1480	1700	1355	1480	1700	1355	1480	1700	mV
$V_{IH}$	Input HIGH Voltage (Single-Ended)	2135		2420	2135		2420	2135		2420	mV
$V_{IL}$	Input LOW Voltage (Single-Ended)	1355		1700	1355		1700	1355		1700	mV
$V_{BB}$	Output Reference Voltage (Note 7)	1775	1875	1975	1775	1875	1975	1775	1875	1975	mV
$V_{IHCMR}$	Input HIGH Voltage Common Mode Range (Differential Configuration) (Note 8)	1.2		3.3	1.2		3.3	1.2		3.3	V
$I_{IH}$	Input HIGH Current			150			150			150	$\mu\text{A}$
$I_{IL}$	Input LOW Current		CLK CLK	0.5 -150			0.5 -150			0.5 -150	$\mu\text{A}$

NOTE: Device will meet the specifications after thermal equilibrium has been established when mounted in a test socket or printed circuit board with maintained transverse airflow greater than 500 lfm. Electrical parameters are guaranteed only over the declared operating temperature range. Functional operation of the device exceeding these conditions is not implied. Device specification limit values are applied individually under normal operating conditions and not valid simultaneously.

5. Input and output parameters vary 1:1 with  $V_{CC}$ .  $V_{EE}$  can vary + 0.925 V to -0.5 V.

6. All loading with 50  $\Omega$  to  $V_{CC} - 2.0\text{ V}$ .

7. Single-ended input operation is limited  $V_{CC} \geq 3.0\text{ V}$  in PECL mode.

8.  $V_{IHCMR}$  min varies 1:1 with  $V_{EE}$ ;  $V_{IHCMR}$  max varies 1:1 with  $V_{CC}$ . The  $V_{IHCMR}$  range is referenced to the most positive side of the differential input signal.

# MC100LVEP210

**Table 6. NECL DC CHARACTERISTICS**  $V_{CC} = 0\text{ V}$ ,  $V_{EE} = -2.375\text{ V}$  to  $-3.8\text{ V}$  (Note 9)

Symbol	Characteristic	-40 °C			25 °C			85 °C			Unit
		Min	Typ	Max	Min	Typ	Max	Min	Typ	Max	
$I_{EE}$	Power Supply Current	55	70	90	55	70	90	55	70	90	mA
$V_{OH}$	Output HIGH Voltage (Note 10)	-1 145	-1020	-895	-1 145	-1020	-895	-1 145	-1020	-895	mV
$V_{OL}$	Output LOW Voltage (Note 10)	-1945	-1820	-1600	-1945	-1820	-1600	-1945	-1820	-1600	mV
$V_{IH}$	Input HIGH Voltage (Single-Ended)	-1 165		-880	-1 165		-880	-1 165		-880	mV
$V_{IL}$	Input LOW Voltage (Single-Ended)	-1945		-1600	-1945		-1600	-1945		-1600	mV
$V_{BB}$	Output Reference Voltage (Note 11)	-1525	-1425	-1325	-1525	-1425	-1325	-1525	-1425	-1325	mV
$V_{IHCMR}$	Input HIGH Voltage Common Mode Range (Differential Configuration) (Note 12)	$V_{EE} + 1.2$		0.0	$V_{EE} + 1.2$		0.0	$V_{EE} + 1.2$		0.0	V
$I_{IH}$	Input HIGH Current			150			150			150	$\mu\text{A}$
$I_{IL}$	Input LOW Current	0.5			0.5			0.5		150	$\mu\text{A}$
	CLK	-150			-150			-150			

NOTE: Device will meet the specifications after thermal equilibrium has been established when mounted in a test socket or printed circuit board with maintained transverse airflow greater than 500 lfpm. Electrical parameters are guaranteed only over the declared operating temperature range. Functional operation of the device exceeding these conditions is not implied. Device specification limit values are applied individually under normal operating conditions and not valid simultaneously.

9. Input and output parameters vary 1:1 with  $V_{CC}$ .

10. All loading with  $50\ \Omega$  to  $V_{CC} - 2.0\text{ V}$ .

11. Single-ended input operation is limited  $V_{EE} \leq -3.0\text{ V}$  in NECL mode.

12.  $V_{IHCMR}$  min varies 1:1 with  $V_{EE}$ ;  $V_{IHCMR}$  max varies 1:1 with  $V_{CC}$ . The  $V_{IHCMR}$  range is referenced to the most positive side of the differential input signal.

**Table 7. HSTL DC CHARACTERISTICS**  $V_{CC} = 2.375$  to  $3.8\text{ V}$ ,  $V_{EE} = 0\text{ V}$

Symbol	Characteristic	-40 °C			25 °C			85 °C			Unit
		Min	Typ	Max	Min	Typ	Max	Min	Typ	Max	
$V_{IH}$	Input HIGH Voltage	1200			1200			1200			mV
$V_{IL}$	Input LOW Voltage			400			400			400	mV
$V_{CM}$	Input Crossover Voltage	680		900	680		900	680		900	mV
$I_{CC}$	Power Supply Current (Outputs Open)	55	70	90	55	70	90	55	70	90	mA

NOTE: Device will meet the specifications after thermal equilibrium has been established when mounted in a test socket or printed circuit board with maintained transverse airflow greater than 500 lfpm. Electrical parameters are guaranteed only over the declared operating temperature range. Functional operation of the device exceeding these conditions is not implied. Device specification limit values are applied individually under normal operating conditions and not valid simultaneously.

# MC100LVEP210

**Table 8. AC CHARACTERISTICS**  $V_{CC} = 0\text{ V}$ ;  $V_{EE} = -2.375\text{ to }-3.8\text{ V}$  or  $V_{CC} = 2.375\text{ to }3.8\text{ V}$ ;  $V_{EE} = 0\text{ V}$  (Note 13)

Symbol	Characteristic	-40 °C			25 °C			85 °C			Unit
		Min	Typ	Max	Min	Typ	Max	Min	Typ	Max	
$f_{\text{maxPECL/HSTL}}$	Maximum Frequency (Figure 4)		3			3			3		GHz
$t_{\text{PLH}}$ $t_{\text{PHL}}$	Propagation Delay Propagation Delay @ 2.5 V	220	300	380	270	350	430	300 330	500 410	750 490	ps
$t_{\text{skew}}$	Within-Device Skew (Note 14) Device-to-Device Skew (Note 15)		20 85	25 160		20 85	25 160		20 85	35 160	ps
$t_{\text{JITTER}}$	CLOCK Random Jitter (RMS) @ $\leq 0.5\text{ GHz}$ @ $\leq 1.0\text{ GHz}$ @ $\leq 1.5\text{ GHz}$ @ $\leq 2.0\text{ GHz}$ @ $\leq 2.5\text{ GHz}$ @ $\leq 3.0\text{ GHz}$		0.184 0.190 0.178 0.196 0.239 0.336	0.3 0.3 0.3 0.3 0.4 0.5		0.207 0.200 0.197 0.233 0.301 0.422	0.3 0.3 0.3 0.4 0.4 0.5		0.271 0.252 0.259 0.308 0.399 0.572	0.4 0.4 0.4 0.5 0.5 0.9	ps
$V_{\text{PP}}$	Minimum Input Swing	150	800	1200	150	800	1200	150	800	1200	mV
$t_{\text{r}}/t_{\text{f}}$	Output Rise/Fall Time (20%-80%)	100	170	250	120	190	270	150	280	350	ps

NOTE: Device will meet the specifications after thermal equilibrium has been established when mounted in a test socket or printed circuit board with maintained transverse airflow greater than 500 lpm. Electrical parameters are guaranteed only over the declared operating temperature range. Functional operation of the device exceeding these conditions is not implied. Device specification limit values are applied individually under normal operating conditions and not valid simultaneously.

13. Measured with 750 mV source, 50% duty cycle clock source. All loading with  $50\ \Omega$  to  $V_{CC} - 2.0\text{ V}$ .

14. Skew is measured between outputs under identical transitions of similar paths through a device.

15. Device-to-Device skew for identical transitions at identical  $V_{CC}$  levels.

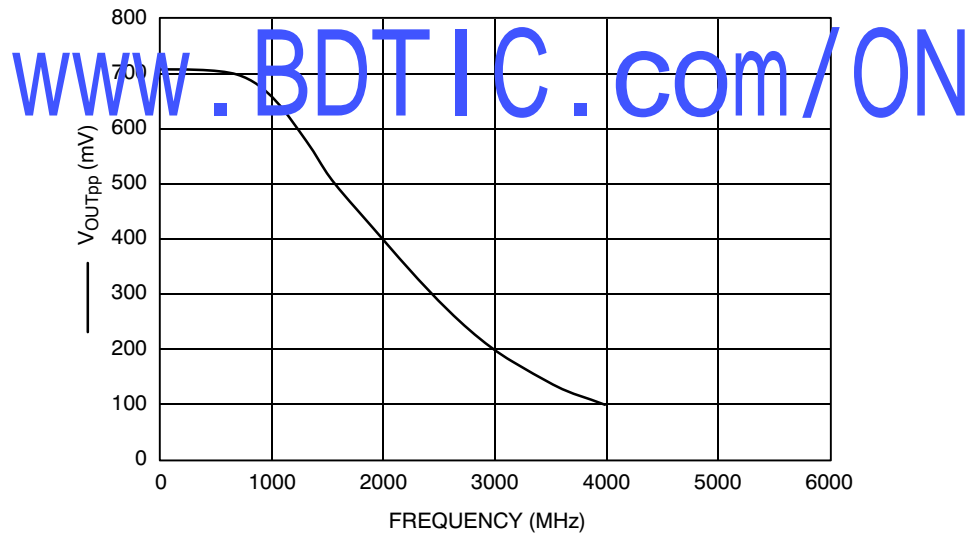

**Figure 4. F<sub>max</sub> Typical**

## MC100LVEP210

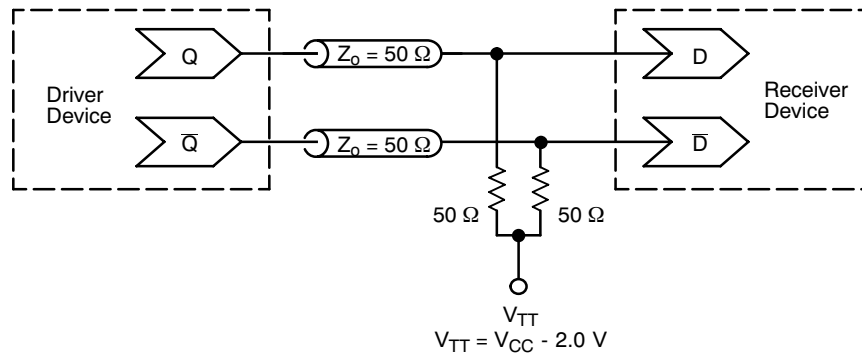

**Figure 5. Typical Termination for Output Driver and Device Evaluation**  
(See Application Note AND8020/D - Termination of ECL Logic Devices.)

### ORDERING INFORMATION

Device	Package	Shipping <sup>†</sup>
MC100LVEP210FA	LQFP	250 Units / Tray
MC100LVEP210FAG	LQFP (Pb-Free)	250 Units / Tray
MC100LVEP210FAR2	LQFP	2000 / Tape & Reel
MC100LVEP210FARG	LQFP (Pb-Free)	2000 / Tape & Reel
MC100LVEP210MNR2G	QFN32 (Pb-Free)	1000 Units / Reel
MC100LVEP210MNR2G	QFN32 (Pb-Free)	1000 / Tape & Reel

<sup>†</sup>For information on tape and reel specifications, including part orientation and tape sizes, please refer to our Tape and Reel Packaging Specifications Brochure, BRD8011/D.

### Resource Reference of Application Notes

- AN1405/D** - ECL Clock Distribution Techniques
- AN1406/D** - Designing with PECL (ECL at +5.0 V)
- AN1503/D** - ECLinPS™ I/O SPICE Modeling Kit
- AN1504/D** - Metastability and the ECLinPS Family
- AN1568/D** - Interfacing Between LVDS and ECL
- AN1672/D** - The ECL Translator Guide
- AND8001/D** - Odd Number Counters Design
- AND8002/D** - Marking and Date Codes
- AND8020/D** - Termination of ECL Logic Devices
- AND8066/D** - Interfacing with ECLinPS
- AND8090/D** - AC Characteristics of ECL Devices

# MC100LVEP210

## PACKAGE DIMENSIONS

32 LEAD LQFP  
CASE 873A-02  
ISSUE C

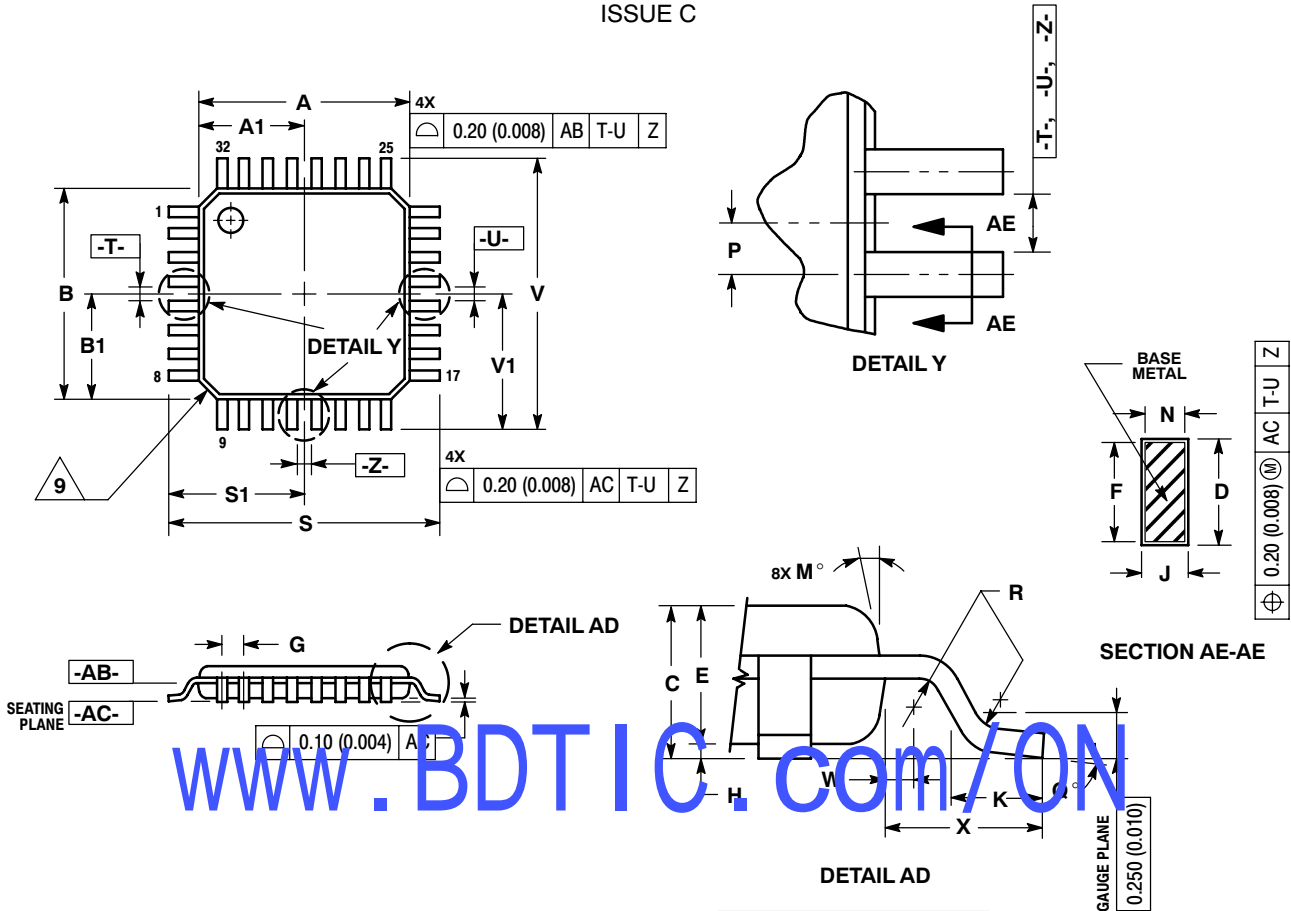

**NOTES:**

- DIMENSIONING AND TOLERANCING PER ANSI Y14.5M, 1982.
- CONTROLLING DIMENSION: MILLIMETER.
- DATUM PLANE -AB- IS LOCATED AT BOTTOM OF LEAD AND IS COINCIDENT WITH THE LEAD WHERE THE LEAD EXITS THE PLASTIC BODY AT THE BOTTOM OF THE PARTING LINE.
- DATUMS -T-, -U-, AND -Z- TO BE DETERMINED AT DATUM PLANE -AB-.
- DIMENSIONS S AND V TO BE DETERMINED AT SEATING PLANE -AC-.
- DIMENSIONS A AND B DO NOT INCLUDE MOLD PROTRUSION. ALLOWABLE PROTRUSION IS 0.250 (0.010) PER SIDE. DIMENSIONS A AND B DO INCLUDE MOLD MISMATCH AND ARE DETERMINED AT DATUM PLANE -AB-.
- DIMENSION D DOES NOT INCLUDE DAMBAR PROTRUSION. DAMBAR PROTRUSION SHALL NOT CAUSE THE D DIMENSION TO EXCEED 0.520 (0.020).
- MINIMUM SOLDER PLATE THICKNESS SHALL BE 0.0076 (0.0003).
- EXACT SHAPE OF EACH CORNER MAY VARY FROM DEPICTION.

DIM	MILLIMETERS		INCHES	
	MIN	MAX	MIN	MAX
A	7.000	BSC	0.276	BSC
A1	3.500	BSC	0.138	BSC
B	7.000	BSC	0.276	BSC
B1	3.500	BSC	0.138	BSC
C	1.400	1.600	0.055	0.063
D	0.300	0.450	0.012	0.018
E	1.350	1.450	0.053	0.057
F	0.300	0.400	0.012	0.016
G	0.800	BSC	0.031	BSC
H	0.050	0.150	0.002	0.006
J	0.090	0.200	0.004	0.008
K	0.450	0.750	0.018	0.030
M	12°	REF	12°	REF
N	0.090	0.160	0.004	0.006
P	0.400	BSC	0.016	BSC
Q	1°	5°	1°	5°
R	0.150	0.250	0.006	0.010
S	9.000	BSC	0.354	BSC
S1	4.500	BSC	0.177	BSC
V	9.000	BSC	0.354	BSC
V1	4.500	BSC	0.177	BSC
W	0.200	REF	0.008	REF
X	1.000	REF	0.039	REF



