

# MC74LVX4245

## Dual Supply Octal Translating Transceiver

### with 3-State Outputs

The 74LVX4245 is a 24-pin dual-supply, octal translating transceiver that is designed to interface between a 5.0 V bus and a 3.0 V bus in a mixed 3.0 V / 5.0 V supply environment such as laptop computers using a 3.3 V CPU and 5.0 V LCD display. The A port interfaces with the 5V bus; the B port interfaces with the 3.0 V bus.

The Transmit/Receive ( $T/\bar{R}$ ) input determines the direction of data flow. Transmit (active-High) enables data from the A port to the B port. Receive (active-Low) enables data from the B port to the A port. The Output Enable ( $\bar{O}E$ ) input, when High, disables both A and B ports by placing them in 3-State.

#### Features

- Bi-directional Interface Between 5.0 V and 3.0 V Buses
- Control Inputs Compatible with TTL Level
- 5.0 V Data Flow at A Port and 3.0 V Data Flow at B Port
- Outputs Source/Sink 24 mA at 5.0 V Bus and 12 mA at 3.0 V Bus
- Guaranteed Simultaneous Switching Noise Level and Dynamic Threshold Performance
- Available in SOIC and TSSOP Packages
- Functionally Compatible with the 74 Series 245
- Pb-Free Packages are Available\*

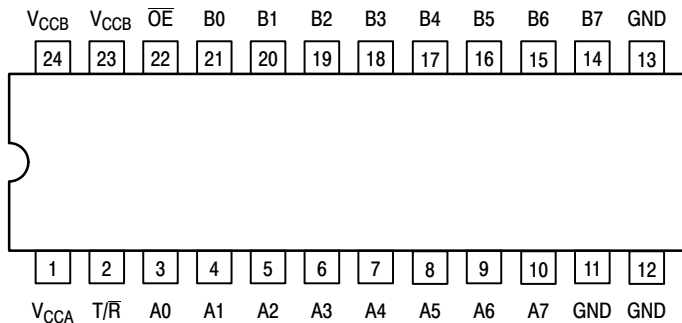

Figure 1. 24-Lead Pinout (Top View)



ON Semiconductor®

<http://onsemi.com>

#### MARKING DIAGRAMS

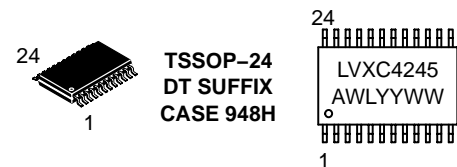
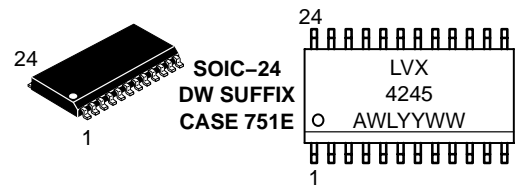

A = Assembly Location  
 WL = Wafer Lot  
 YY = Year  
 WW = Work Week

#### PIN NAMES

Pins	Function
$\bar{O}E$	Output Enable Input
$T/\bar{R}$	Transmit/Receive Input
A0–A7	Side A 3-State Inputs or 3-State Outputs
B0–B7	Side B 3-State Inputs or 3-State Outputs

#### ORDERING INFORMATION

See detailed ordering and shipping information in the package dimensions section on page 5 of this data sheet.

\*For additional information on our Pb-Free strategy and soldering details, please download the ON Semiconductor Soldering and Mounting Techniques Reference Manual, SOLDERRM/D.

# MC74LVX4245

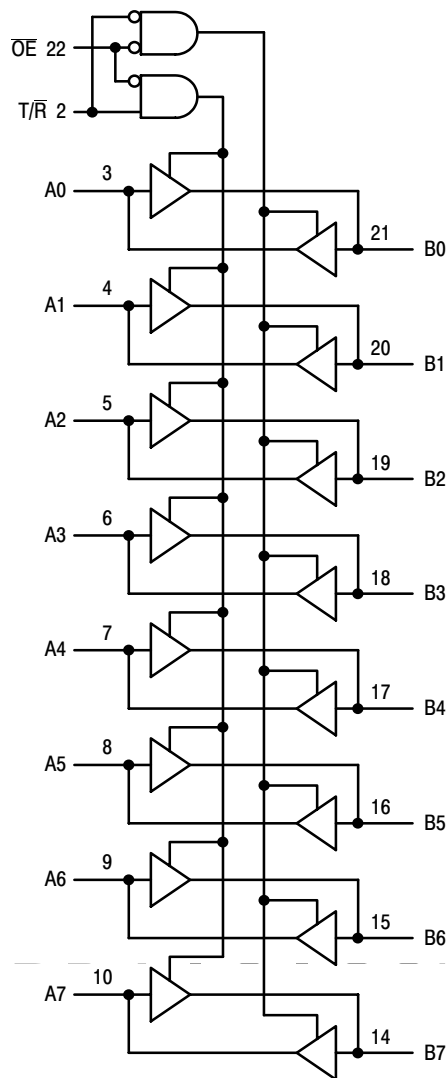

Figure 2. Logic Diagram

INPUTS		OPERATING MODE Non-Inverting
OE	T/R	
L	L	B Data to A Bus
L	H	A Data to B Bus
H	X	Z

H = High Voltage Level; L = Low Voltage Level; Z = High Impedance State; X = High or Low Voltage Level and Transitions are Acceptable; For I<sub>CC</sub> reasons, Do Not Float Inputs

# MC74LVX4245

## ABSOLUTE MAXIMUM RATINGS

Symbol	Parameter	Value	Condition	Unit
$V_{CCA}, V_{CCB}$	DC Supply Voltage	-0.5 to +7.0		V
$V_I$	DC Input Voltage $\overline{OE}, T/R$	-0.5 to $V_{CCA} + 0.5$		V
$V_{I/O}$	DC Input/Output Voltage	An	-0.5 to $V_{CCA} + 0.5$	V
		Bn	-0.5 to $V_{CCB} + 0.5$	V
$I_{IK}$	DC Input Diode Current $\overline{OE}, T/R$	$\pm 20$	$V_I < GND$	mA
$I_{OK}$	DC Output Diode Current	$\pm 50$	$V_O < GND; V_O > V_{CC}$	mA
$I_O$	DC Output Source/Sink Current	$\pm 50$		mA
$I_{CC}, I_{GND}$	DC Supply Current Per Output Pin Maximum Current at $I_{CCA}$ Maximum Current at $I_{CCB}$	$\pm 50$ $\pm 200$ $\pm 100$		mA
$T_{STG}$	Storage Temperature Range	-65 to +150		$^{\circ}C$
Latchup	DC Latchup Source/Sink Current	$\pm 300$		mA

Maximum ratings are those values beyond which device damage can occur. Maximum ratings applied to the device are individual stress limit values (not normal operating conditions) and are not valid simultaneously. If these limits are exceeded, device functional operation is not implied, damage may occur and reliability may be affected.

## RECOMMENDED OPERATING CONDITIONS

Symbol	Parameter	Min	Max	Unit
$V_{CCA}, V_{CCB}$	Supply Voltage $V_{CCA}$ $V_{CCB}$	4.5 2.7	5.5 3.6	V
$V_I$	Input Voltage $\overline{OE}, T/R$	0	$V_{CCA}$	V
$V_{I/O}$	Input/Output Voltage	An	0	$V_{CCA}$
		Bn	0	$V_{CCB}$
$T_A$	Operating Free-Air Temperature	-40	+85	$^{\circ}C$
$\Delta t/\Delta V$	Minimum Input Edge Rate $V_{IN}$ from 30% to 70% of $V_{CC}$ ; $V_{CC}$ at 3.0V, 4.5V, 5.5V	0	8	ns/V

## DC ELECTRICAL CHARACTERISTICS

Symbol	Parameter	Condition	$V_{CCA}$	$V_{CCB}$	$T_A = 25^{\circ}C$		$T_A = -40$ to $+85^{\circ}C$		Unit
					Typ	Guaranteed Limits			
$V_{IHA}$	Minimum HIGH Level Input Voltage	$V_{OUT} \leq 0.1V$ or $\geq V_{CC} - 0.1V$	5.5	3.3		2.0	2.0	V	
			4.5	3.3		2.0	2.0		
$V_{IHB}$	Input Voltage	$\geq V_{CC} - 0.1V$	5.0	3.6		2.0	2.0	V	
			5.0	2.7		2.0	2.0		
$V_{ILA}$	Maximum LOW Level Input Voltage	$V_{OUT} \leq 0.1V$ or $\geq V_{CC} - 0.1V$	5.5	3.3		0.8	0.8	V	
			4.5	3.3		0.8	0.8		
$V_{ILB}$	Input Voltage	$\geq V_{CC} - 0.1V$	5.0	2.7		0.8	0.8	V	
			5.0	3.6		0.8	0.8		
$V_{OHA}$	Minimum HIGH Level Output Voltage	$I_{OUT} = -100\mu A$ $I_{OH} = -24mA$	4.5	3.0	4.50	4.40	4.40	V	
			4.5	3.0	4.25	3.86	3.76		
$V_{OHB}$	Output Voltage	$I_{OUT} = -100\mu A$ $I_{OH} = -12mA$ $I_{OH} = -8mA$	4.5	3.0	2.99	2.9	2.9	V	
			4.5	3.0	2.80	2.4	2.4		
			4.5	2.7	2.50	2.4	2.4		
$V_{OLA}$	Maximum LOW Level Output Voltage	$I_{OUT} = 100\mu A$ $I_{OL} = 24mA$	4.5	3.0	0.002	0.10	0.10	V	
			4.5	3.0	0.18	0.36	0.44		
$V_{OLB}$	Output Voltage	$I_{OUT} = 100\mu A$ $I_{OL} = 12mA$ $I_{OL} = 8mA$	4.5	3.0	0.002	0.10	0.10	V	
			4.5	3.0	0.1	0.31	0.40		
			4.5	2.7	0.1	0.31	0.40		

# MC74LVX4245

## DC ELECTRICAL CHARACTERISTICS

Symbol	Parameter	Condition	V <sub>CCA</sub>	V <sub>CCB</sub>	T <sub>A</sub> = 25°C		T <sub>A</sub> = -40 to +85°C		Unit	
					Typ	Guaranteed Limits				
I <sub>IN</sub>	Max Input Leakage Current	$\overline{OE}, T/\overline{R}$ V <sub>I</sub> = V <sub>CCA</sub> , GND	5.5	3.6		±0.1	±1.0		μA	
I <sub>OZA</sub>	Max 3-State Output Leakage	An V <sub>I</sub> = V <sub>IH</sub> , V <sub>IL</sub> OE = V <sub>CCA</sub> V <sub>O</sub> = V <sub>CCA</sub> , GND	5.5	3.6		±0.5	±5.0		μA	
I <sub>OZB</sub>	Max 3-State Output Leakage	Bn V <sub>I</sub> = V <sub>IH</sub> , V <sub>IL</sub> OE = V <sub>CCA</sub> V <sub>O</sub> = V <sub>CCB</sub> , GND	5.5	3.6		±0.5	±5.0		μA	
ΔI <sub>CC</sub>	Maximum I <sub>CC</sub> T per Input	An, $\overline{OE}$ T/ $\overline{R}$	V <sub>I</sub> =V <sub>CCA</sub> -2.1V	5.5	3.6	1.0	1.35	1.5		mA
		Bn	V <sub>I</sub> =V <sub>CCB</sub> -0.6V	5.5	3.6		0.35	0.5		mA
I <sub>CCA</sub>	Quiescent V <sub>CCA</sub> Supply Current	An=V <sub>CCA</sub> or GND Bn=V <sub>CCB</sub> or GND OE=GND T/ $\overline{R}$ =GND	5.5	3.6		8	80		μA	
I <sub>CCB</sub>	Quiescent V <sub>CCB</sub> Supply Current	An=V <sub>CCA</sub> or GND Bn=V <sub>CCB</sub> or GND OE=GND T/ $\overline{R}$ =V <sub>CCA</sub>	5.5	3.6		5	50		μA	
V <sub>OLPA</sub> V <sub>OLPB</sub>	Quiet Output Max Dynamic V <sub>OL</sub>	Notes 1, 2	5.0 5.0	3.3 3.3		1.5 1.2			V	
V <sub>OLVA</sub> V <sub>OLVB</sub>	Quiet Output Min Dynamic V <sub>OL</sub>	Notes 1, 2	5.0 5.0	3.3 3.3		-1.2 -0.8			V	
V <sub>IHDA</sub> V <sub>IHDB</sub>	Min HIGH Level Dynamic Input Voltage	Notes 1, 3	5.0 5.0	3.3 3.3		2.0 2.0			V	
V <sub>ILDA</sub> V <sub>ILDB</sub>	Max LOW Level Dynamic Input Voltage	Notes 1, 3	5.0 5.0	3.3 3.3		0.8 0.8			V	

1. Worst case package.
2. Max number of outputs defined as (n). Data inputs are driven 0V to V<sub>CC</sub> level; one output at GND.
3. Max number of data inputs (n) switching. (n-1) inputs switching 0V to V<sub>CC</sub> level. Input under test switching: V<sub>CC</sub> level to threshold (V<sub>IHD</sub>), 0V to threshold (V<sub>ILD</sub>), f = 1MHz.

## CAPACITIVE CHARACTERISTICS

Symbol	Parameter	Condition	Typical	Unit
C <sub>IN</sub>	Input Capacitance	V <sub>CCA</sub> = 5.0V; V <sub>CCB</sub> = 3.3V	4.5	pF
C <sub>I/O</sub>	Input/Output Capacitance	V <sub>CCA</sub> = 5.0V; V <sub>CCB</sub> = 3.3V	15	pF
C <sub>PD</sub>	Power Dissipation Capacitance (Measured at 10MHz)	B→A	V <sub>CCA</sub> = 5.0V	55
		A→B	V <sub>CCB</sub> = 3.3V	40

# MC74LVX4245

## AC ELECTRICAL CHARACTERISTICS

Symbol	Parameter	$T_A = -40 \text{ to } +85^\circ\text{C}$ $C_L = 50\text{pF}$			$T_A = -40 \text{ to } +85^\circ\text{C}$ $C_L = 50\text{pF}$		Unit
		$V_{CCA} = 5V \pm 0.5V$ $V_{CCB} = 3.3V \pm 0.3V$			$V_{CCA} = 5V \pm 0.5V$ $V_{CCB} = 2.7V$		
		Min	Typ (Note 4)	Max	Min	Max	
$t_{PHL}$ $t_{PLH}$	Propagation Delay A to B	1.0 1.0	5.1 5.3	9.0 9.0	1.0 1.0	10.0 10.0	ns
$t_{PHL}$ $t_{PLH}$	Propagation Delay B to A	1.0 1.0	5.4 5.5	9.0 9.0	1.0 1.0	10.0 10.0	ns
$t_{PZL}$ $t_{PZH}$	Output Enable Time $\overline{OE}$ to B	1.0 1.0	6.5 6.7	10.5 10.5	1.0 1.0	11.5 11.5	ns
$t_{PZL}$ $t_{PZH}$	Output Enable Time $\overline{OE}$ to A	1.0 1.0	5.2 5.8	9.5 9.5	1.0 1.0	10.0 10.0	ns
$t_{PHZ}$ $t_{PLZ}$	Output Disable Time $\overline{OE}$ to B	1.0 1.0	6.0 3.3	10.0 7.0	1.0 1.0	10.0 7.5	ns
$t_{PHZ}$ $t_{PLZ}$	Output Disable Time $\overline{OE}$ to A	1.0 1.0	3.9 2.9	7.5 7.0	1.0 1.0	7.5 7.5	ns
$t_{OSHL}$ $t_{OSLH}$	Output to Output Skew, Data to Output (Note 5)		1.0	1.5		1.5	ns

4. Typical values at  $V_{CCA} = 5.0V$ ;  $V_{CCB} = 3.3V$  at  $25^\circ\text{C}$ .

5. Skew is defined as the absolute value of the difference between the actual propagation delay for any two separate outputs of the same device. The specification applies to any outputs switching in the same direction, either HIGH-to-LOW ( $t_{OSHL}$ ) or LOW-to-HIGH ( $t_{OSLH}$ ); parameter guaranteed by design.

## ORDERING INFORMATION

Device	Package	Shipping†
MC74LVX4245DW	SOIC-24	30 Units / Rail
MC74LVX4245DWR2	SOIC-24	1000 Tape & Reel
MC74LVX4245DWR2G	SOIC-24 (Pb-Free)	1000 Tape & Reel
MC74LVX4245DT	TSSOP-24*	62 Units / Rail
MC74LVX4245DTR2	TSSOP-24*	2500 Tape & Reel

†For information on tape and reel specifications, including part orientation and tape sizes, please refer to our Tape and Reel Packaging Specifications Brochure, BRD8011/D.

\*This package is inherently Pb-Free.

## MC74LVX4245

### Dual Supply Octal Translating Transceiver

The 74LVX4245 is a dual-supply device well capable of bidirectional signal voltage translation. This level shifting ability provides an excellent interface between low voltage CPU local bus and a standard 5.0 V I/O bus. The device control inputs can be controlled by either the low voltage CPU and core logic or a bus arbitrator with 5.0 V I/O levels.

The LVX4245 is ideal for mixed voltage applications such as notebook computers using a 3.3 V CPU and 5.0 V peripheral devices.

### Applications:

#### Mixed Mode Dual Supply Interface Solutions

The LVX4245 is designed to solve 3.0 V / 5.0 V interfaces when CMOS devices cannot tolerate I/O levels above their applied  $V_{CC}$ . If an I/O pin of a 3.0 V device is driven by a 5.0 V device, the P-Channel transistor in the 3.0 V device will conduct – causing current flow from the I/O bus to the 3.0 V power supply. The result may be destruction of the 3.0 V device through latchup effects. A current limiting resistor may be used to prevent destruction, but it causes speed degradation and needless power dissipation.

A better solution is provided in the LVX4245. It provides two different output levels that easily handle the dual voltage interface. The A port is a dedicated 5.0 V port; the B port is a dedicated 3.0 V port.

Since the LVX4245 is a '245 transceiver, the user may either use it for bidirectional or unidirectional applications. The center 20 pins are configured to match a '245 pinout. This enables the user to easily replace this level shifter with a 3.0 V '245 device without additional layout work or re-manufacture of the circuit board (when both buses are 3.0 V).

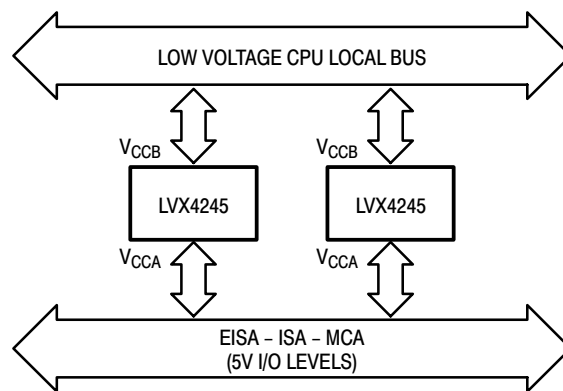

Figure 3. 3.3V/5V Interface Block Diagram

### Powering Up the LVX4245

When powering up the LVX4245, please note that if the  $V_{CCB}$  pin is powered-up well in advance of the  $V_{CCA}$  pin, several milliamps of either  $I_{CCA}$  or  $I_{CCB}$  current will result. If the  $V_{CCA}$  pin is powered-up in advance of the  $V_{CCB}$  pin then only nanoamps of  $I_{CC}$  current will result. In actuality the  $V_{CCB}$  can be powered “slightly” before the  $V_{CCA}$  without the current penalty, but this “setup time” is dependent on the power-up ramp rate of the  $V_{CC}$  pins. With a ramp rate of approximately 50 mV/ns (50V/ $\mu$ s) a 25 ns setup time was observed ( $V_{CCB}$  before  $V_{CCA}$ ). With a 7.0 V/ $\mu$ s rate, the setup time was about 140ns. When all is said and done, the safest powerup strategy is to simply power  $V_{CCA}$  before  $V_{CCB}$ . One more note: if the  $V_{CCB}$  ramp rate is faster than the  $V_{CCA}$  ramp rate then power problems might still occur, even if the  $V_{CCA}$  powerup began prior to the  $V_{CCB}$  powerup.

# MC74LVX4245

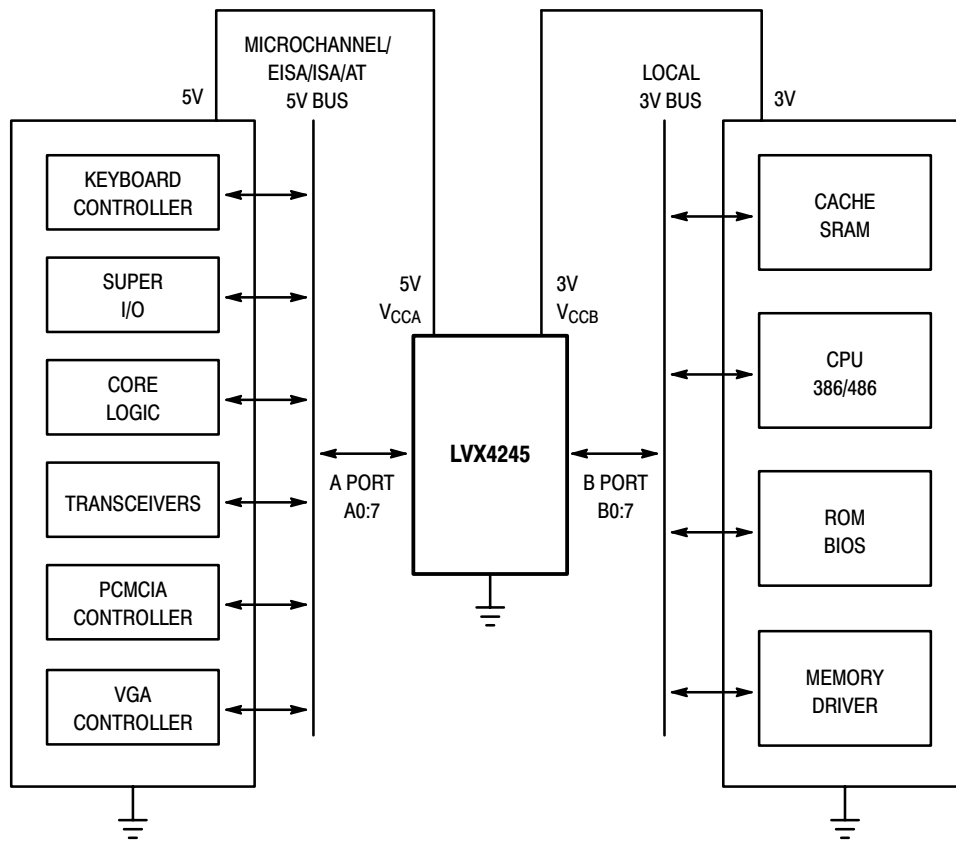

Figure 4. MC74LVX4245 Fits Into a System with 3V Subsystem and 5V Subsystem

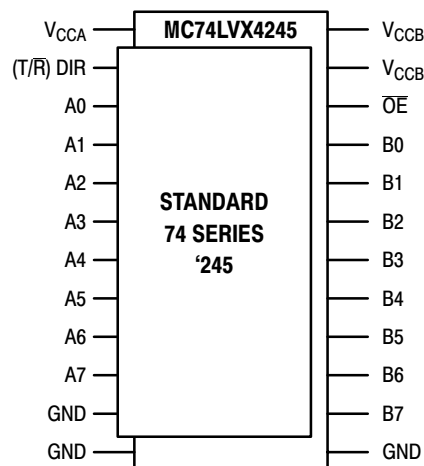
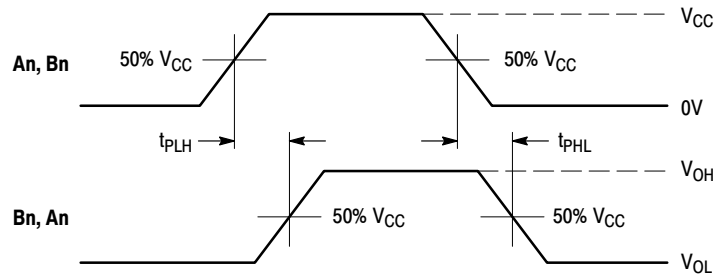
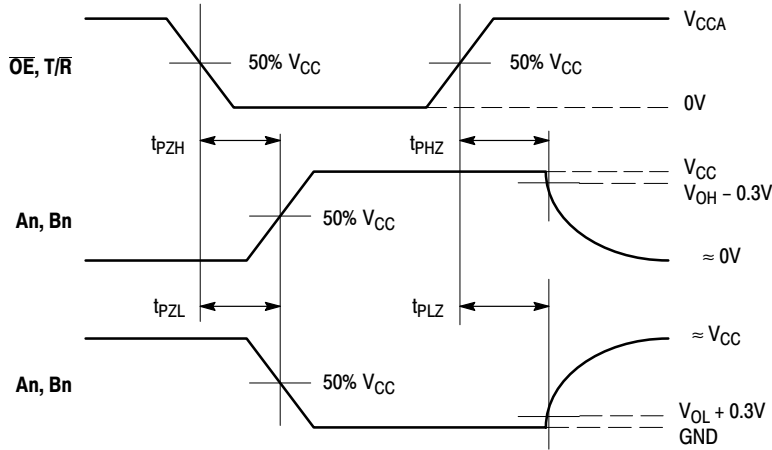

Figure 5. MC74LVX4245 Pin Arrangement Is Compatible to 20-Pin 74 Series '245s

# MC74LVX4245



**WAVEFORM 1 - PROPAGATION DELAYS**  
 $t_R = t_F = 2.5\text{ns}$ , 10% to 90%;  $f = 1\text{MHz}$ ;  $t_W = 500\text{ns}$



**WAVEFORM 2 - OUTPUT ENABLE AND DISABLE TIMES**  
 $t_R = t_F = 2.5\text{ns}$ , 10% to 90%;  $f = 1\text{MHz}$ ;  $t_W = 500\text{ns}$

**Figure 6. AC Waveforms**

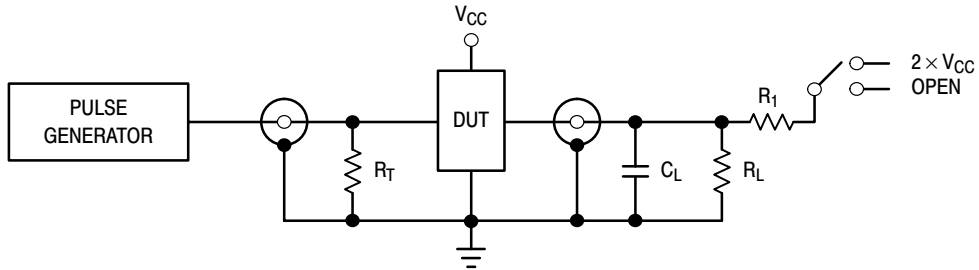

TEST	SWITCH
$t_{PLH}$ , $t_{PHL}$ , $t_{PZH}$ , $t_{PHZ}$	Open
$t_{PZL}$ , $t_{PLZ}$	$2 \times V_{CC}$

$C_L = 50\text{pF}$  or equivalent (Includes jig and probe capacitance)  
 $R_L = R_1 = 500\Omega$  or equivalent  
 $R_T = Z_{OUT}$  of pulse generator (typically  $50\Omega$ )

**Figure 7. Test Circuit**



# MC74LVX4245

## PACKAGE DIMENSIONS

SOIC-24  
DW SUFFIX  
CASE 751E-04  
ISSUE E

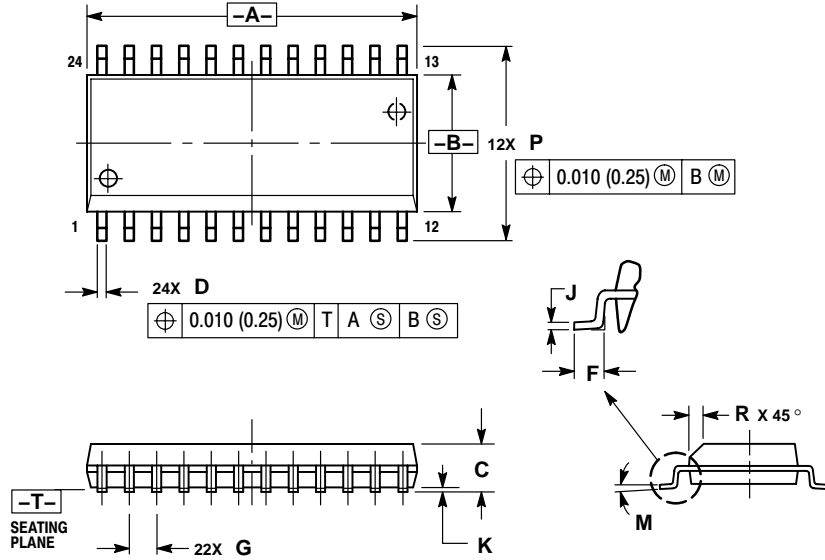

### NOTES:

1. DIMENSIONING AND TOLERANCING PER ANSI Y14.5M, 1982.
2. CONTROLLING DIMENSION: MILLIMETER.
3. DIMENSIONS A AND B DO NOT INCLUDE MOLD PROTRUSION.
4. MAXIMUM MOLD PROTRUSION 0.15 (0.006) PER SIDE.
5. DIMENSION D DOES NOT INCLUDE DAMBAR PROTRUSION. ALLOWABLE DAMBAR PROTRUSION SHALL BE 0.13 (0.005) TOTAL IN EXCESS OF D DIMENSION AT MAXIMUM MATERIAL CONDITION.

DIM	MILLIMETERS		INCHES	
	MIN	MAX	MIN	MAX
A	15.25	15.54	0.601	0.612
B	7.40	7.60	0.292	0.299
C	2.35	2.65	0.093	0.104
D	0.35	0.49	0.014	0.019
F	0.41	0.90	0.016	0.035
G	1.27 BSC		0.050 BSC	
J	0.23	0.32	0.009	0.013
K	0.13	0.29	0.005	0.011
M	0° - 8°		0° - 8°	
P	10.05	10.55	0.395	0.415
R	0.25	0.75	0.010	0.029

# MC74LVX4245

## PACKAGE DIMENSIONS

TSSOP-24  
DT SUFFIX  
CASE 948H-01  
ISSUE A

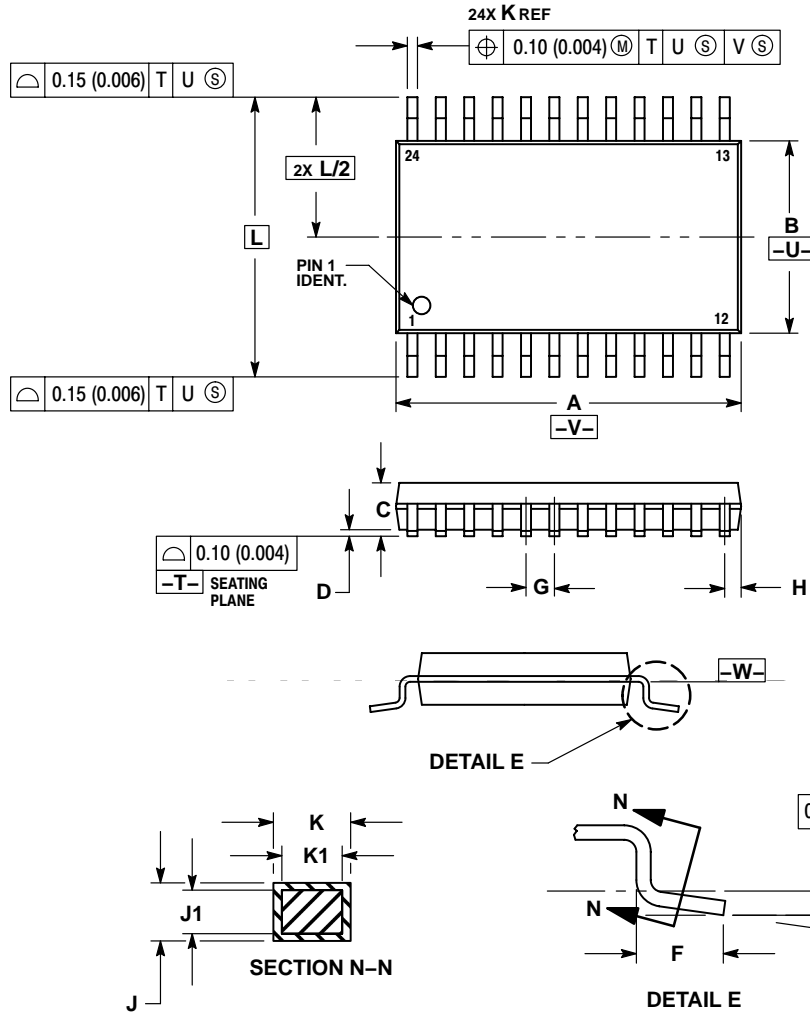

- NOTES:
1. DIMENSIONING AND TOLERANCING PER ANSI Y14.5M, 1982.
  2. CONTROLLING DIMENSION: MILLIMETER.
  3. DIMENSION A DOES NOT INCLUDE MOLD FLASH, PROTRUSIONS OR GATE BURRS. MOLD FLASH OR GATE BURRS SHALL NOT EXCEED 0.15 (0.006) PER SIDE.
  4. DIMENSION B DOES NOT INCLUDE INTERLEAD FLASH OR PROTRUSION. INTERLEAD FLASH OR PROTRUSION SHALL NOT EXCEED 0.25 (0.010) PER SIDE.
  5. DIMENSION K DOES NOT INCLUDE DAMBAR PROTRUSION. ALLOWABLE DAMBAR PROTRUSION SHALL BE 0.08 (0.003) TOTAL IN EXCESS OF THE K DIMENSION AT MAXIMUM MATERIAL CONDITION.
  6. TERMINAL NUMBERS ARE SHOWN FOR REFERENCE ONLY.
  7. DIMENSION A AND B ARE TO BE DETERMINED AT DATUM PLANE -W-.

DIM	MILLIMETERS		INCHES	
	MIN	MAX	MIN	MAX
A	7.70	7.90	0.303	0.311
B	4.30	4.50	0.169	0.177
C	---	1.20	---	0.047
D	0.05	0.15	0.002	0.006
F	0.50	0.75	0.020	0.030
G	0.65 BSC		0.026 BSC	
H	0.27	0.37	0.011	0.015
J	0.09	0.20	0.004	0.008
J1	0.09	0.16	0.004	0.006
K	0.19	0.30	0.007	0.012
K1	0.19	0.25	0.007	0.010
L	6.40 BSC		0.252 BSC	
M	0°	8°	0°	8°

ON Semiconductor and are registered trademarks of Semiconductor Components Industries, LLC (SCILLC). SCILLC reserves the right to make changes without further notice to any products herein. SCILLC makes no warranty, representation or guarantee regarding the suitability of its products for any particular purpose, nor does SCILLC assume any liability arising out of the application or use of any product or circuit, and specifically disclaims any and all liability, including without limitation special, consequential or incidental damages. "Typical" parameters which may be provided in SCILLC data sheets and/or specifications can and do vary in different applications and actual performance may vary over time. All operating parameters, including "Typicals" must be validated for each customer application by customer's technical experts. SCILLC does not convey any license under its patent rights nor the rights of others. SCILLC products are not designed, intended, or authorized for use as components in systems intended for surgical implant into the body, or other applications intended to support or sustain life, or for any other application in which the failure of the SCILLC product could create a situation where personal injury or death may occur. Should Buyer purchase or use SCILLC products for any such unintended or unauthorized application, Buyer shall indemnify and hold SCILLC and its officers, employees, subsidiaries, affiliates, and distributors harmless against all claims, costs, damages, and expenses, and reasonable attorney fees arising out of, directly or indirectly, any claim of personal injury or death associated with such unintended or unauthorized use, even if such claim alleges that SCILLC was negligent regarding the design or manufacture of the part. SCILLC is an Equal Opportunity/Affirmative Action Employer. This literature is subject to all applicable copyright laws and is not for resale in any manner.

### PUBLICATION ORDERING INFORMATION

**LITERATURE FULFILLMENT:**  
Literature Distribution Center for ON Semiconductor  
P.O. Box 61312, Phoenix, Arizona 85082-1312 USA  
**Phone:** 480-829-7710 or 800-344-3860 Toll Free USA/Canada  
**Fax:** 480-829-7709 or 800-344-3867 Toll Free USA/Canada  
**Email:** orderlit@onsemi.com

**N. American Technical Support:** 800-282-9855 Toll Free  
USA/Canada

**Japan:** ON Semiconductor, Japan Customer Focus Center  
2-9-1 Kamimeguro, Meguro-ku, Tokyo, Japan 153-0051  
**Phone:** 81-3-5773-3850

**ON Semiconductor Website:** <http://onsemi.com>

**Order Literature:** <http://www.onsemi.com/litorder>

For additional information, please contact your local Sales Representative.