

# NB7L216

## 2.5V/3.3V, 12Gb/s Multi Level Clock/Data Input to RSECL, High Gain Receiver/Buffer/Translator with Internal Termination

### Description

The NB7L216 is a differential receiver/driver with high gain output targeted for high frequency applications. The device is functionally equivalent to the NBSG16 but with much higher gain output. This highly versatile device provides 35 dB of gain up to 7 GHz.

Inputs incorporate internal 50 Ω termination resistors and accept Negative ECL (NECL), Positive ECL (PECL), LVTTTL, LVCMOS, CML, or LVDS. Outputs are Reduced Swing ECL (RSECL), 400 mV.

The  $V_{BB}$  pin is an internally generated voltage supply available to this device only.  $V_{BB}$  is used as a reference voltage for single-ended NECL or PECL inputs. For all single-ended input conditions, the unused complementary differential input should be connected to  $V_{BB}$  as a switching reference voltage.  $V_{BB}$  may also rebias AC coupled inputs. When used, decouple  $V_{BB}$  via a 0.01 μF capacitor and limit current sourcing or sinking to 0.5 mA. When not used,  $V_{BB}$  output should be left open.

Application notes, models and support documentation are available at [www.onsemi.com](http://www.onsemi.com).

### Features

- High Gain of 35 dB from DC to 7 GHz Typical
- High IIP3: 0 dBm Typical
- 20 mV Minimum Input Voltage Swing
- Maximum Input Clock Frequency up to 8.5 GHz
- Maximum Input Data Rate up to 12 Gb/s Typical
- <0.5 ps of RMS Clock Jitter
- <9 ps of Data Dependent Jitter
- 120 ps Typical Propagation Delay
- 30 ps Typical Rise and Fall Times
- RSPECL Output with Operating Range:  $V_{CC} = 2.375$  V to 3.465 V with  $V_{EE} = 0$  V
- RSNECL Output with RSNECL or NECL Inputs with Operating Range:  $V_{CC} = 0$  V with  $V_{EE} = -2.375$  V to  $-3.465$  V
- RSECL Output Level (400 mV Peak-to-Peak Output),
- 50 Ω Internal Input Termination Resistors (Temperature-Coefficient of < 6.38 mΩ/°C)
- $V_{BB}$  – ECL Reference Voltage Output
- Pb-Free Packages are Available



ON Semiconductor®

<http://onsemi.com>

### MARKING DIAGRAM\*



QFN-16  
MN SUFFIX  
CASE 485G

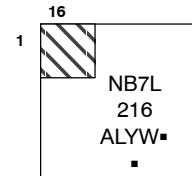

A = Assembly Location  
L = Wafer Lot  
Y = Year  
W = Work Week  
▪ = Pb-Free Package

(Note: Microdot may be in either location)

\*For additional marking information, refer to Application Note AND8002/D.

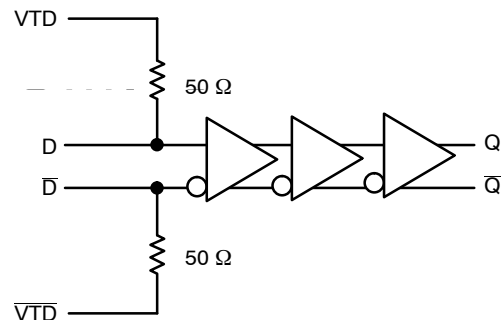

Figure 1. Functional Block Diagram

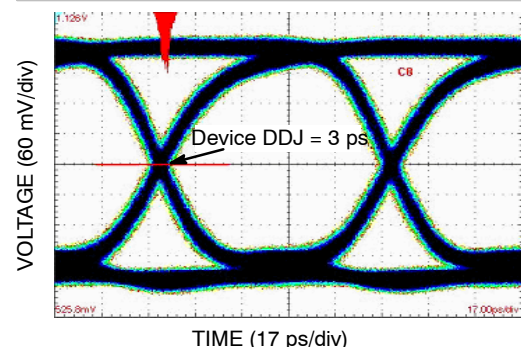

Figure 2. Typical Output Waveform at 12 Gb/s with PRBS 223-1 ( $V_{INPP} = 400$  mV, Input Signal DDJ = 12 ps)

### ORDERING INFORMATION

See detailed ordering and shipping information in the package dimensions section on page 11 of this data sheet.

# NB7L216

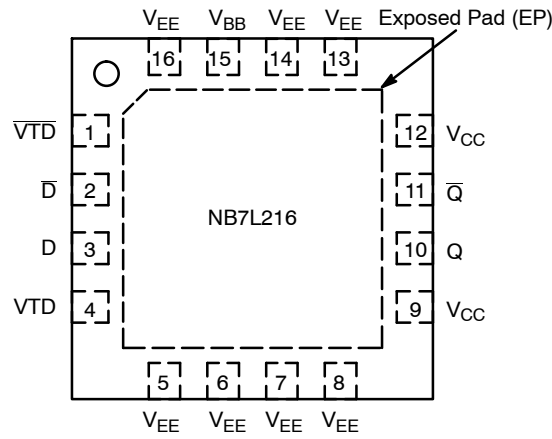

Figure 3. QFN-16 Pinout (Top View)

Table 1. PIN DESCRIPTION

Pin	Name	I/O	Description
1	$\overline{VTD}$	-	Internal 50 $\Omega$ termination pin. See Table 7. Note 1
2	$\overline{D}$	LVPECL, CML, LVCMOS, LVDS, LVTTTL Input	Inverted differential input. Note 1.
3	D	LVPECL, CML, LVCMOS, LVDS, LVTTTL Input	Noninverted differential input. Note 1.
4	VTD	-	Internal 50 $\Omega$ termination pin. See Table 7. Note 1.
15	$V_{BB}$	- - - - -	Internally generated ECL reference voltage supply.
5, 6, 7, 8, 13, 14, 16	$V_{EE}$	-	Negative supply voltage. All $V_{EE}$ pins must be externally connected to power supply to guarantee proper operation.
9, 12	$V_{CC}$	-	Positive supply voltage. All $V_{CC}$ pins must be externally connected to power supply to guarantee proper operation
10	Q	RSECL Output	Noninverted differential output. Typically receiver terminated with 50 $\Omega$ resistor to $V_{TT} = V_{CC} - 2.0$ V.
11	$\overline{Q}$	RSECL Output	Inverted differential output. Typically receiver terminated with 50 $\Omega$ resistor to $V_{TT} = V_{CC} - 2.0$ V.
-	EP	-	Exposed pad (EP). Thermally exposed pad on the package bottom must be attached to a heat sinking conduit. It is recommended to connect the EP to the lower potential, $V_{EE}$ .

1. In the differential configuration when the input termination pins ( $\overline{VTD}$ , VTD) are connected to a common termination voltage and if no signal is applied on D/ $\overline{D}$  input then the device will be susceptible to self-oscillation.

# NB7L216

**Table 2. ATTRIBUTES**

Characteristics		Value	
ESD Protection	Human Body Model	> 500 V	
	Machine Model	> 10 V	
	Charged Device Model	> 4 kV	
Moisture Sensitivity (Note 2)		Pb Pkg	Pb-Free Pkg
QFN-16		Level 1	Level 1
Flammability Rating	Oxygen Index: 28 to 34	UL 94 V-0 @ 0.125 in	
Transistor Count		164	
Meets or exceeds JEDEC Spec EIA/JESD78 IC Latchup Test.			

2. For additional information, see Application Note AND8003/D.

**Table 3. MAXIMUM RATINGS** (Note 3)

Symbol	Parameter	Condition 1	Condition 2	Rating	Unit
V <sub>CC</sub>	Positive Power Supply	V <sub>EE</sub> = 0 V		3.6	V
V <sub>EE</sub>	Negative Power Supply	V <sub>CC</sub> = 0 V		-3.6	V
V <sub>I</sub>	Positive Input Negative Input	V <sub>EE</sub> = 0 V V <sub>CC</sub> = 0 V	V <sub>I</sub> = V <sub>CC</sub> V <sub>I</sub> = V <sub>EE</sub>	3.6 -3.6	V V
V <sub>INPP</sub>	Differential Input Voltage	D - $\bar{D}$		2.8	V
I <sub>IN</sub>	Input Current Through R <sub>T</sub> (50 Ω Resistor)	Static Surge		45 80	mA mA
I <sub>OUT</sub>	Output Current	Continuous Surge		25 50	mA mA
I <sub>BB</sub>	V <sub>BB</sub> Sink/Source			± 0.5	mA
T <sub>A</sub>	Operating Temperature Range			-40 to +85	°C
T <sub>stg</sub>	Storage Temperature Range			-65 to +150	°C
θ <sub>JA</sub>	Thermal Resistance (Junction-to-Ambient) (Note 4)	0 lfpm 500 lfpm	QFN-16 QFN-16	42 35	°C/W °C/W
θ <sub>JC</sub>	Thermal Resistance (Junction-to-Case)	1S2P (Note 4)	QFN-16	4	°C/W
T <sub>sol</sub>	Wave Solder	Pb Pb-Free		265 265	°C

Stresses exceeding Maximum Ratings may damage the device. Maximum Ratings are stress ratings only. Functional operation above the Recommended Operating Conditions is not implied. Extended exposure to stresses above the Recommended Operating Conditions may affect device reliability.

- Maximum ratings applied to the device are individual stress limit values (not normal operating conditions) and are not valid simultaneously. If stress limits are exceeded device functional operation is not implied, damage may occur and reliability may be affected.
- JEDEC standard multilayer board – 1S2P (1 signal, 2 power) with 8 filled thermal vias under exposed pad.

# NB7L216

**Table 4. DC CHARACTERISTICS, CLOCK INPUTS, RSECL OUTPUTS**  $V_{CC} = 2.375\text{ V to }3.465\text{ V}$ ,  $V_{EE} = 0\text{ V}$

Symbol	Characteristic	-40 °C			25 °C			85 °C			Unit
		Min	Typ	Max	Min	Typ	Max	Min	Typ	Max	
$I_{EE}$	Power Supply Current (VTD/VTD open)		27	35		27	35		27	35	mA
$V_{OH}$	Output HIGH Voltage (Note 5 and 6)	$V_{CC} - 1040$	$V_{CC} - 980$	$V_{CC} - 940$	$V_{CC} - 1000$	$V_{CC} - 950$	$V_{CC} - 900$	$V_{CC} - 950$	$V_{CC} - 900$	$V_{CC} - 850$	mV
$V_{OL}$	Output LOW Voltage (Note 5 and 6)	$V_{CC} - 1520$	$V_{CC} - 1430$	$V_{CC} - 1320$	$V_{CC} - 1470$	$V_{CC} - 1370$	$V_{CC} - 1270$	$V_{CC} - 1440$	$V_{CC} - 1340$	$V_{CC} - 1240$	mV

**DIFFERENTIAL INPUT DRIVEN SINGLE-ENDED** (see Figures 14 and 16)

$V_{TH}$	Input Threshold Reference Voltage Range (Note 7 and 8)	1100		$V_{CC} - 10$	1100		$V_{CC} - 10$	1100		$V_{CC} - 10$	mV
$V_{IH}$	Single-ended Input HIGH Voltage (Note 8)	$V_{th} + 10$		$V_{CC}$	$V_{th} + 10$		$V_{CC}$	$V_{th} + 10$		$V_{CC}$	mV
$V_{IL}$	Single-ended Input LOW Voltage (Note 8)	$V_{EE}$		$V_{th} - 10$	$V_{EE}$		$V_{th} - 10$	$V_{EE}$		$V_{th} - 10$	mV

**DIFFERENTIAL INPUTS DRIVEN DIFFERENTIALLY** (see Figures 15 and 17)

$V_{IHD}$	Differential Input HIGH Voltage (Note 9)	1105		$V_{CC}$	1105		$V_{CC}$	1105		$V_{CC}$	mV
$V_{ILD}$	Differential Input LOW Voltage (Note 9)	$V_{EE}$		$V_{CC} - 10$	$V_{EE}$		$V_{CC} - 10$	$V_{EE}$		$V_{CC} - 10$	mV
$V_{CMR}$	Input Common Mode Range (Differential Configuration, Note 9 and 10)	1100		$V_{CC} - 5$	1100		$V_{CC} - 5$	1100		$V_{CC} - 5$	mV
$V_{ID}$	Differential Input Voltage ( $V_{IHD} - V_{ILD}$ )	10		2500	10		2500	10		2500	mV
$V_{IO}$	Input Offset Voltage (Note 11)	-5	0	+5	-5	0	+5	-5	0	+5	mV
$V_{BB}$	Internally Generated Reference Voltage Supply (Only 3 V - 3.6 V Supply Load with -100 $\mu$ A)	$V_{CC} - 1425$	$V_{CC} - 1345$	$V_{CC} - 1265$	$V_{CC} - 1425$	$V_{CC} - 1345$	$V_{CC} - 1265$	$V_{CC} - 1425$	$V_{CC} - 1345$	$V_{CC} - 1265$	mV
$I_{IH}$	Input HIGH Current D/Db (VTD/VTD Open)	0	20	100	0	20	100	0	20	100	$\mu$ A
$I_{IL}$	Input LOW Current D/Db (VTD/VTD Open)	-25	10	75	-25	10	75	-25	10	75	$\mu$ A
$R_{TIN}$	Internal Input Termination Resistor	45	50	55	45	50	55	45	50	55	$\Omega$
$R_{T\_Coef}$	Internal Input Termination Resistor Temperature Coefficient		6.38			6.38			6.38		m $\Omega$ /°C

NOTE: Device will meet the specifications after thermal equilibrium has been established when mounted in a test socket or printed circuit board with maintained airflow greater than 500 lfm. Electrical parameters are guaranteed only over the declared operating temperature range. Functional operation of the device exceeding these conditions is not implied. Device specification limit values are applied individually under normal operating conditions and not valid simultaneously.

5. Outputs evaluated with 50  $\Omega$  resistors to  $V_{TT} = V_{CC} - 2.0\text{ V}$  for proper operation.
6. Input and output parameters vary 1:1 with  $V_{CC}$ .
7.  $V_{TH}$  is applied to the complementary input when operating in single-ended mode.
8.  $V_{IH}$ ,  $V_{IL}$  and  $V_{TH}$  parameters must be complied simultaneously.
9.  $V_{IHD}$ ,  $V_{ILD}$  and  $V_{CMR}$  parameters must be complied simultaneously.
10.  $V_{CMR}$  min varies 1:1 with  $V_{EE}$ ,  $V_{CMR}$  max varies 1:1 with  $V_{CC}$ .
11. Typical standard deviation of input offset voltage is 1.76 mV.

# NB7L216

**Table 5. AC CHARACTERISTICS**  $V_{CC} = 2.375\text{ V to }3.465\text{ V}$ ,  $V_{EE} = 0\text{ V}$ ; (Note 12)

Symbol	Characteristic	-40°C			25°C			85°C			Unit
		Min	Typ	Max	Min	Typ	Max	Min	Typ	Max	
$V_{OUTPP}$	Output Voltage Amplitude (@ $V_{INPPmin}$ ) $f_{in} \leq 7.0\text{ GHz}$ (See Figure 4) $f_{in} \leq 8.5\text{ GHz}$	275 100	380 250		275 100	380 250		275 100	380 250		mV
$f_{DATA}$	Maximum Operating Data Rate	10	12		10	12		10	12		Gb/s
S21	Power Gain DC to 7 GHz		35			35			35		dB
S11	Input Return Loss @ 7 GHz		-10			-10			-10		dB
S22	Output Return Loss @ 7 GHz		-5			-5			-5		dB
S12	Reverse Isolation (Differential Configuration)		-25			-25			-25		dB
IIP3	Input Third Order Intercept		0			0			0		dBm
$t_{PLH}$ , $t_{PHL}$	Propagation Delay to Output Differential @ 1 GHz	60	120	180	60	120	180	60	120	180	ps
$t_{SKEW}$	Duty Cycle Skew (Note 12) Device to Device Skew (Note 17)		2 5	10 20		2 5	10 20		2 5	10 20	ps
$t_{JITTER}$	RMS Random Clock Jitter $f_{in} \leq 8.5\text{ GHz}$ (Note 15) Peak-to-Peak Data Dependent Jitter (Note 16) $f_{DATA} = 3.5\text{ Gb/s}$ $f_{DATA} = 5.0\text{ Gb/s}$ $f_{DATA} = 10\text{ Gb/s}$ $f_{DATA} = 12\text{ Gb/s}$		0.1 1 3 4 4	0.5 7 9 9 9		0.1 1 3 4 4	0.5 7 9 9 9		0.1 1 3 4 4	0.5 7 9 9 9	ps
$V_{INPP}$	Input Voltage Swing/Sensitivity (Differential Configuration) (Note 14 and Figure 12)	20		2500	20		2500	20		2500	mV
$t_r$ , $t_f$	Output Rise/Fall Times @ 0.5 GHz $Q, \bar{Q}$ (20% – 80%)		30	45		30	45		30	45	ps

NOTE: Device will meet the specifications after thermal equilibrium has been established when mounted in a test socket or printed circuit board with maintained airflow greater than 500 lfm. Electrical parameters are guaranteed only over the declared operating temperature range. Functional operation of the device exceeding these conditions is not implied. Device specification limit values are applied individually under normal operating conditions and not valid simultaneously.

12. Measured by forcing  $V_{INPPmin}$  from a 50% duty cycle clock source. All loading with an external  $R_L = 50\ \Omega$  to  $V_{TT} = V_{CC} - 2.0\text{ V}$ . Input edge rates 40 ps (20% – 80%).

13. Duty cycle skew is measured between differential outputs using the deviations of the sum of  $T_{pw-}$  and  $T_{pw+}$  @ 1 GHz.

14.  $V_{INPP}$  (MAX) cannot exceed  $V_{CC} - V_{EE}$ . Input voltage swing is a single-ended measurement operating in differential mode.

15. Additive RMS jitter with 50% duty cycle clock signal.

16. Additive peak-to-peak data dependent jitter with input NRZ data at PRBS  $2^{23}-1$ .

17. Device to device skew is measured between outputs under identical transition @ 1 GHz.

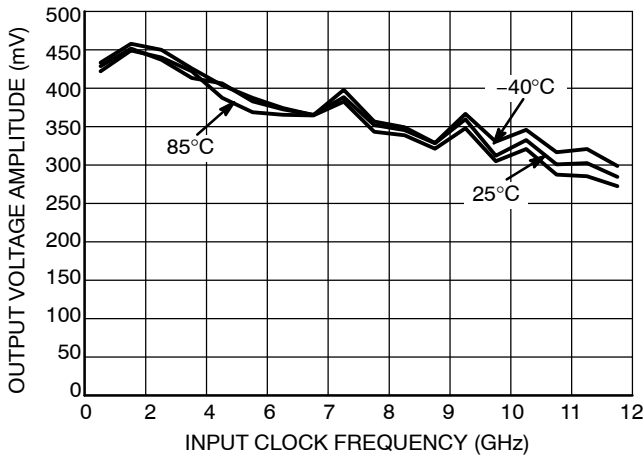

**Figure 4. Output Voltage Amplitude ( $V_{OUTPP}$ ) versus Input Clock Frequency ( $f_{IN}$ ) and Temperature ( $V_{INPP} = 400\text{ mV}$ ,  $V_{CC} = 3.3\text{ V}$  and  $V_{EE} = 0\text{ V}$ )**

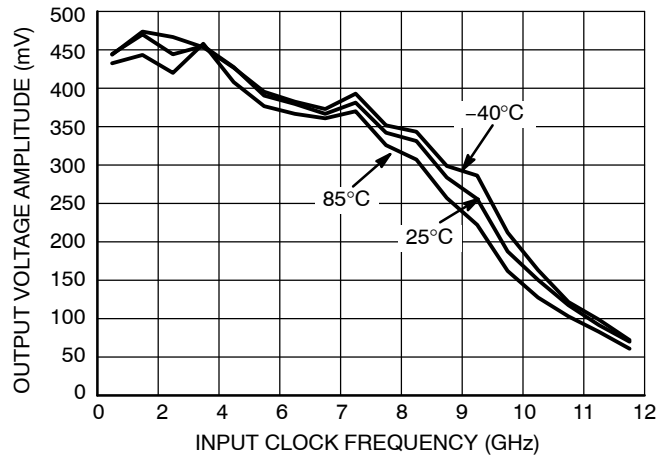

**Figure 5. Output Voltage Amplitude ( $V_{OUTPP}$ ) versus Input Clock Frequency ( $f_{IN}$ ) and Temperature ( $V_{INPP} = 20\text{ mV}$ ,  $V_{CC} = 3.3\text{ V}$  and  $V_{EE} = 0\text{ V}$ )**

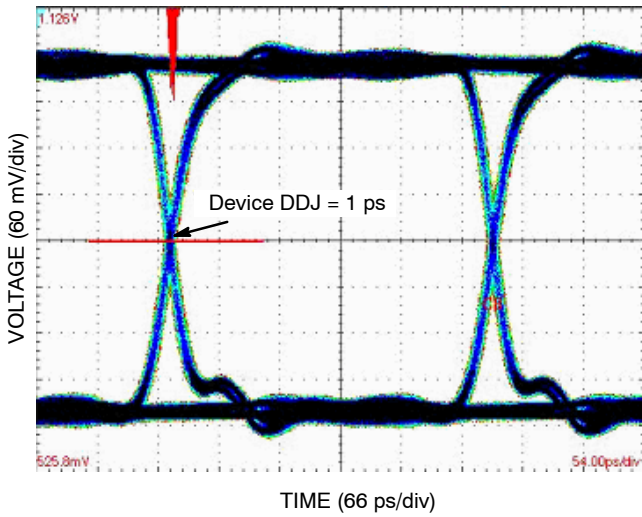

Figure 6. Typical Output Waveform at 2.488 Gb/s with PRBS  $2^{23}-1$  ( $V_{INPP} = 400$  mV, Input Signal DDJ = 12 ps)

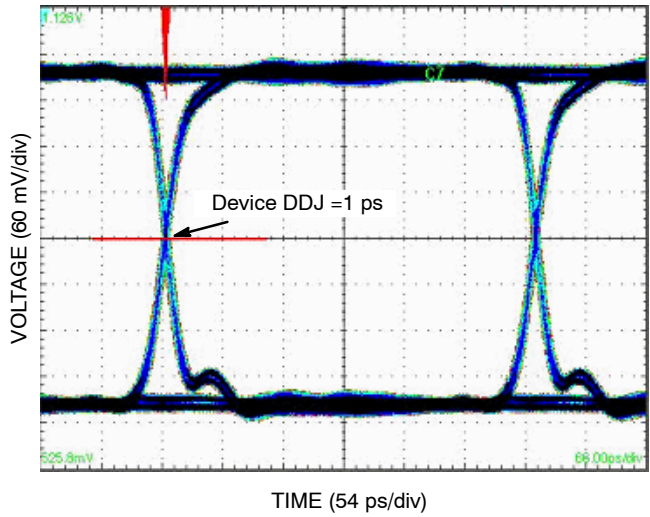

Figure 7. Typical Output Waveform at 3.5 Gb/s with PRBS  $2^{23}-1$  ( $V_{INPP} = 400$  mV, Input Signal DDJ = 12 ps)

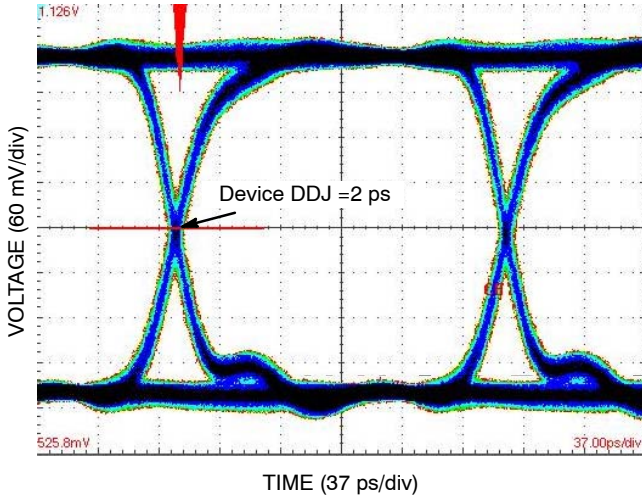

Figure 8. Typical Output Waveform at 5 Gb/s with PRBS  $2^{23}-1$  ( $V_{INPP} = 400$  mV, Input Signal DDJ = 12 ps)

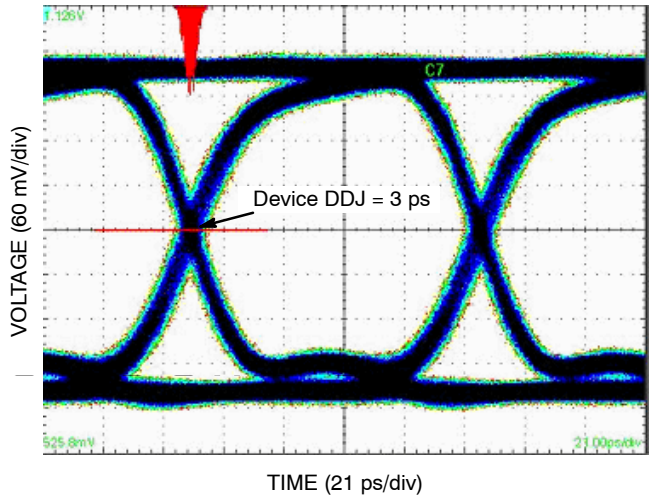

Figure 9. Typical Output Waveform at 10 Gb/s with PRBS  $2^{23}-1$  ( $V_{INPP} = 400$  mV, Input Signal DDJ = 12 ps)

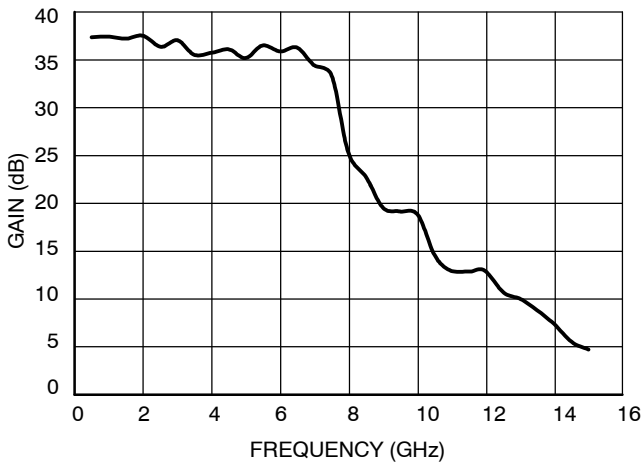

Figure 10. Small Signal Gain – S21 Magnitude\*

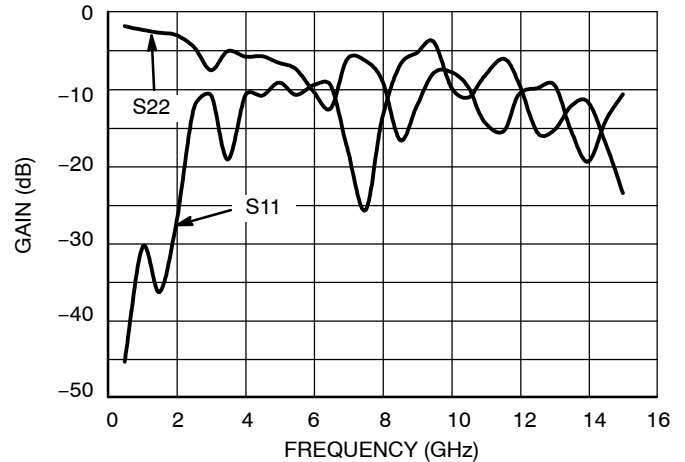

Figure 11. Input and Output Reflection – S11 and S22 Magnitude\*

\* $T_A = +25^\circ\text{C}$ ,  $V_{CC} = 3.3$  V,  $V_{EE} = 0$  V,  $P_{IN} = -44$  dBm,  $Z_S = Z_L = 50$   $\Omega$ , input and output matching network is not included.

# NB7L216

**Table 6. TYPICAL DEVICE S-PARAMETERS**

Frequency (Hz)	S11			S21			S12			S22		
	dbS11	S11	∠S11	dbS21	S21	∠S21	dbS12	S12	∠S12	dbS22	S22	∠S22
4.97E+08	-45.2	0.005	-88.5	37.2	72.799	-33.2	-72.3	0.001	-139.1	-2.5	0.749	157.4
1.02E+09	-30.4	0.030	-134.7	37.3	73.145	-68.4	-45.8	0.005	129.8	-2.9	0.714	154.3
1.51E+09	-36.2	0.015	-146.5	37.1	71.433	-105.4	-43.3	0.007	98.5	-2.9	0.717	132.8
2.00E+09	-27.4	0.042	25.7	37.4	74.061	-139.0	-37.1	0.014	91.8	-3.5	0.666	107.1
2.52E+09	-12.3	0.244	-27.7	36.2	64.810	-179.5	-29.9	0.032	54.4	-4.4	0.599	92.1
3.01E+09	-10.6	0.295	-83.8	36.9	70.102	144.5	-26.1	0.050	9.4	-6.3	0.485	77.3
3.50E+09	-19.0	0.112	-22.1	35.4	58.933	99.9	-28.3	0.038	25.9	-5.0	0.566	67.9
4.02E+09	-10.6	0.294	-120.3	35.6	60.437	73.8	-24.8	0.058	-32.6	-7.6	0.417	54.2
4.51E+09	-10.7	0.291	167.4	36.0	62.843	41.1	-22.5	0.075	-68.3	-13.9	0.201	70.2
4.99E+09	-9.0	0.354	87.1	35.1	56.576	14.2	-25.2	0.055	-107.2	-8.7	0.367	81.2
5.48E+09	-10.6	0.294	62.7	36.4	65.812	-16.1	-24.3	0.061	-121.4	-8.0	0.398	50.4
6.01E+09	-9.3	0.341	108.2	35.8	61.327	-72.8	-24.5	0.060	-125.7	-8.0	0.397	-0.9
6.49E+09	-9.4	0.340	59.4	36.2	64.212	-119.4	-21.9	0.080	-152.4	-12.5	0.237	-27.2
6.98E+09	-17.5	0.133	25.5	34.3	52.039	-141.5	-22.7	0.073	177.5	-7.4	0.428	-32.2
7.51E+09	-25.6	0.053	107.9	33.2	45.861	164.6	-24.4	0.060	165.7	-7.0	0.445	-37.9
7.99E+09	-13.7	0.206	146.5	25.2	18.093	133.6	-21.5	0.084	152.8	-7.6	0.416	-54.7
8.52E+09	-6.7	0.462	117.9	22.6	13.434	116.2	-19.4	0.107	120.7	-12.1	0.249	-73.7
9.00E+09	-5.2	0.552	106.2	19.4	9.336	102.0	-19.0	0.112	109.9	-12.2	0.246	-62.5
9.49E+09	-3.7	0.652	71.1	19.0	8.937	61.1	-19.4	0.107	62.0	-11.5	0.267	-100.2
1.00E+10	-9.7	0.326	46.2	18.7	8.595	18.6	-24.0	0.063	50.6	-10.4	0.301	-117.0
1.05E+10	-11.0	0.283	35.8	14.5	5.298	-13.3	-25.9	0.051	12.9	-10.8	0.288	-172.0
1.10E+10	-8.3	0.384	7.2	12.9	4.408	-9.6	-29.4	0.034	21.1	-13.4	0.213	74.0
1.15E+10	-5.9	0.506	-0.4	12.7	4.339	-33.7	-21.4	0.085	36.3	-21.4	0.085	-148.6
1.20E+10	-9.0	0.356	-23.8	12.9	4.395	-63.4	-19.4	0.107	-9.5	-13.4	0.214	159.5
1.25E+10	-15.6	0.166	-46.9	10.5	3.360	-97.8	-21.0	0.089	-39.0	-12.4	0.239	169.2
1.30E+10	-15.1	0.175	-83.0	9.9	3.121	-119.7	-24.0	0.063	-39.9	-11.3	0.272	171.6
1.35E+10	-12.0	0.250	-96.5	8.7	2.728	-148.9	-22.0	0.079	-39.1	-14.9	0.181	177.8
1.40E+10	-11.5	0.265	-105.9	7.3	2.314	-167.1	-18.6	0.118	-74.2	-18.4	0.120	140.3
1.45E+10	-17.0	0.140	-97.8	5.4	1.856	167.6	-20.1	0.099	-107.0	-15.7	0.163	98.2
1.50E+10	-23.4	0.068	-108.9	4.6	1.695	145.0	-20.2	0.098	-128.1	-11.2	0.274	96.1

NOTE:  $T_A = +25^\circ\text{C}$ ,  $V_{CC}=3.3\text{V}$ ,  $V_{EE} = 0\text{V}$ ,  $P_{IN} = -44\text{ dBm}$ ,  $Z_S = Z_L = 50\ \Omega$ , input and output matching network is not included.

# NB7L216

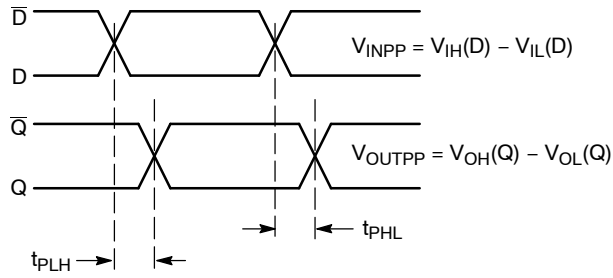

Figure 12. AC Reference Measurement

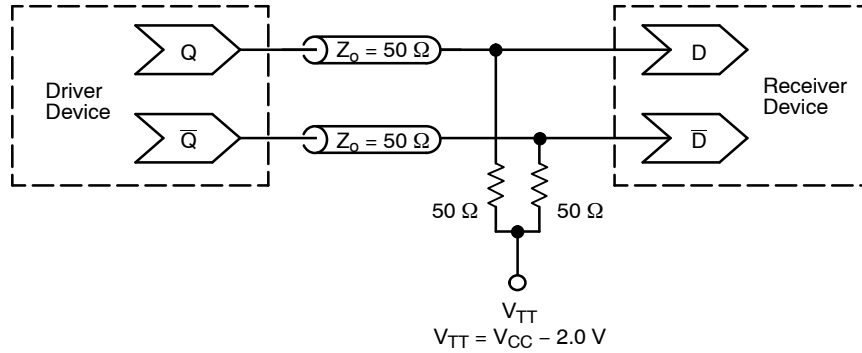

Figure 13. Typical Termination for Output Driver and Device Evaluation (See Application Note AND8020/D – Termination of ECL Logic Devices.)

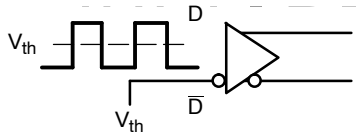

Figure 14. Differential Input Driven Single-Ended

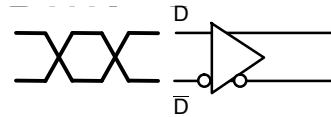

Figure 15. Differential Inputs Driven Differentially

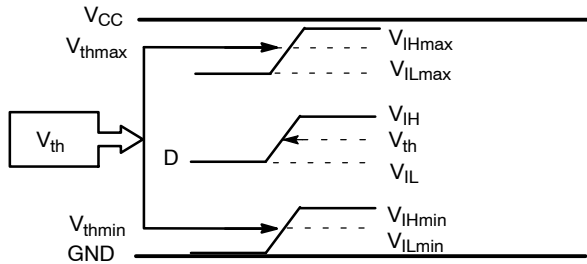

Figure 16.  $V_{th}$  Diagram

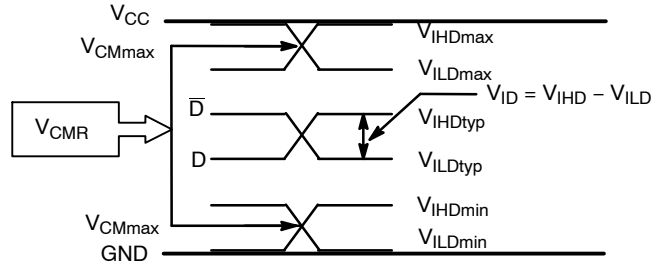

Figure 17.  $V_{CMR}$  Diagram

NOTE:  $V_{EE} \leq V_{IN} \leq V_{CC}$ ;  $V_{IH} > V_{IL}$



# NB7L216

## APPLICATION INFORMATION

All NB7L216 inputs can accept PECL, CML, LVTTTL, LVCMOS and LVDS signal levels. The limitations for differential input signal (LVDS, PECL, or CML) are minimum input swing of 75 mV and the maximum input swing of 2500 mV. Within these conditions, the input voltage can range from  $V_{CC}$  to 1.2 V. Examples interfaces are illustrated below in a 50  $\Omega$  environment ( $Z = 50 \Omega$ ). For output termination and interface, refer to application note AND8020/D.

**Table 7. INTERFACING OPTIONS**

Interfacing Options	Connections
CML	Connect VTD and $\overline{VTD}$ to $V_{CC}$ (See Figure 18)
LVDS	Connect VTD and $\overline{VTD}$ Together (See Figure 20)
AC-COUPLED	Bias VTD and $\overline{VTD}$ Inputs within Common Mode Range ( $V_{CMR}$ ) (See Figure 19)
RSECL, PECL, NECL	Standard ECL Termination Techniques (See Figure 13)
LVTTTL, LVCMOS	An External Voltage ( $V_{THR}$ ) should be Applied to the Unused Complementary Differential Input. Nominal $V_{THR}$ is 1.5 V for LVTTTL and $V_{CC} / 2$ for LVCMOS Inputs. This Voltage must be within the $V_{THR}$ Specification. (See Figure 21)

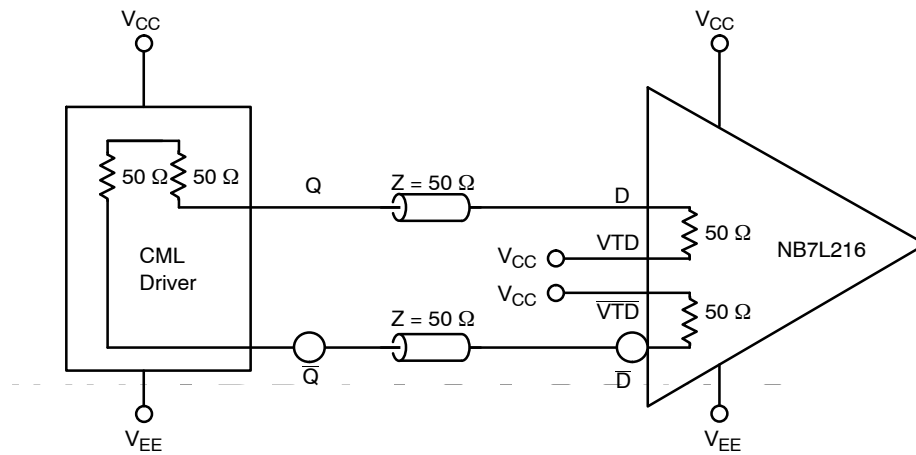

**Figure 18. CML to NB7L216 Interface**

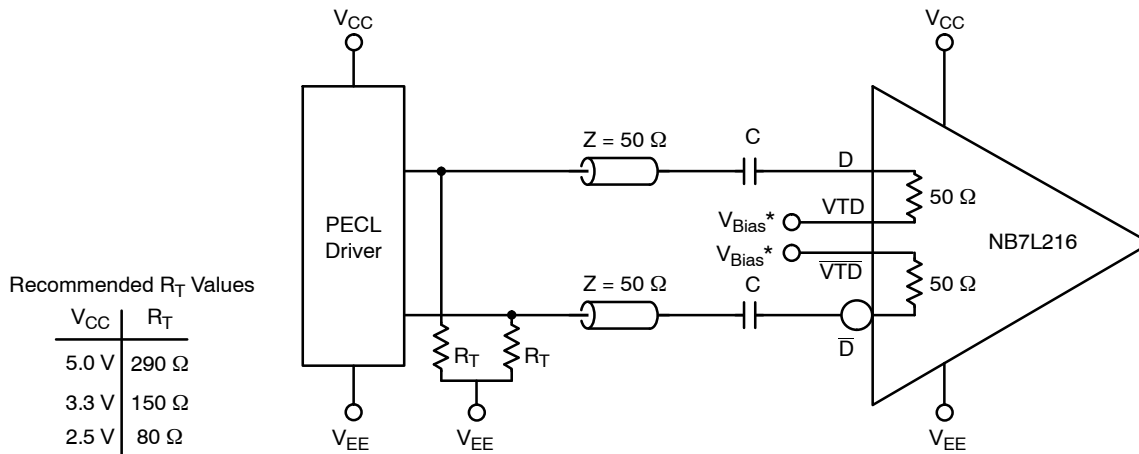

Recommended  $R_T$  Values

$V_{CC}$	$R_T$
5.0 V	290 $\Omega$
3.3 V	150 $\Omega$
2.5 V	80 $\Omega$

\* $V_{Bias}$  must be within common mode range limits ( $V_{CMR}$ )

**Figure 19. PECL to NB7L216 Interface**

# NB7L216

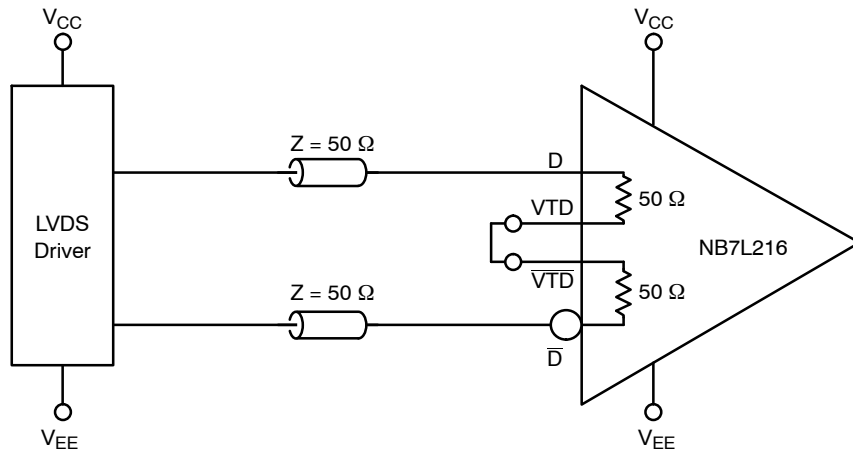

Figure 20. LVDS to NB7L216 Interface

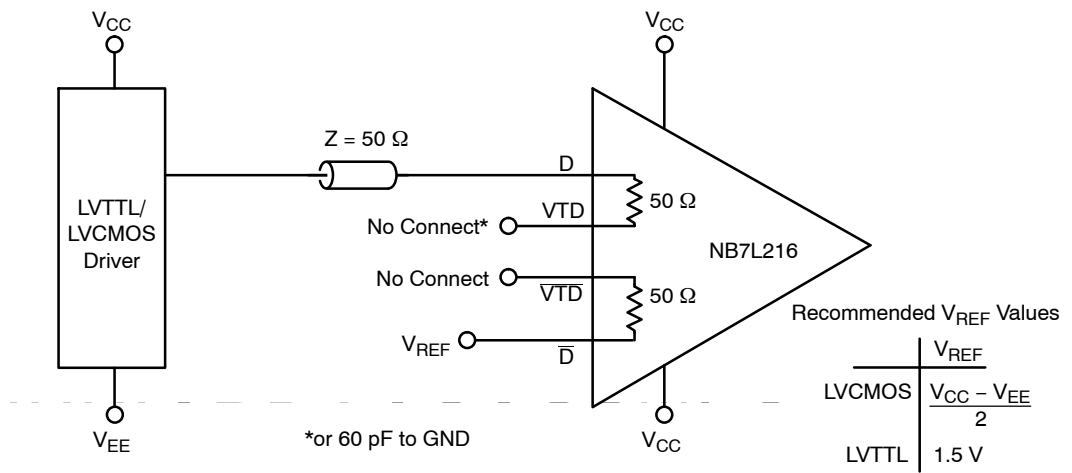

Figure 21. LVCMOS/LVTTL to NB7L216 Interface

# NB7L216

## ORDERING INFORMATION

Device	Package	Shipping†
NB7L216MN	QFN-16	123 Units / Rail
NB7L216MNG	QFN-16 (Pb-Free)	123 Units / Rail
NB7L216MNR2	QFN-16	3000 / Tape & Reel
NB7L216MNR2G	QFN-16 (Pb-Free)	3000 / Tape & Reel

†For information on tape and reel specifications, including part orientation and tape sizes, please refer to our Tape and Reel Packaging Specifications Brochure, BRD8011/D.

# NB7L216

## PACKAGE DIMENSIONS

16 PIN QFN  
CASE 485G-01  
ISSUE C

DATE 02 MAR 2006

SCALE 2:1

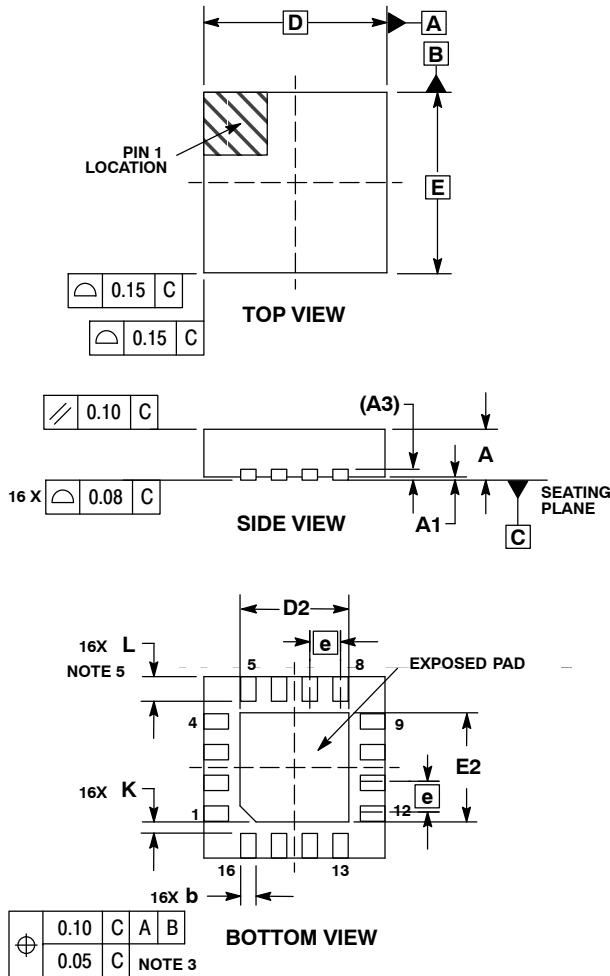

**NOTES:**

1. DIMENSIONING AND TOLERANCING PER ASME Y14.5M, 1994.
2. CONTROLLING DIMENSION: MILLIMETERS.
3. DIMENSION b APPLIES TO PLATED TERMINAL AND IS MEASURED BETWEEN 0.25 AND 0.30 MM FROM TERMINAL.
4. COPLANARITY APPLIES TO THE EXPOSED PAD AS WELL AS THE TERMINALS.
5.  $L_{max}$  CONDITION CAN NOT VIOLATE 0.2 MM MINIMUM SPACING BETWEEN LEAD TIP AND FLAG

MILLIMETERS		
DIM	MIN	MAX
A	0.80	1.00
A1	0.00	0.05
A3	0.20 REF	
b	0.18	0.30
D	3.00 BSC	
D2	1.65	1.85
E	3.00 BSC	
E2	1.65	1.85
e	0.50 BSC	
K	0.18 TYP	
L	0.30	0.50

**SOLDERING FOOTPRINT\***

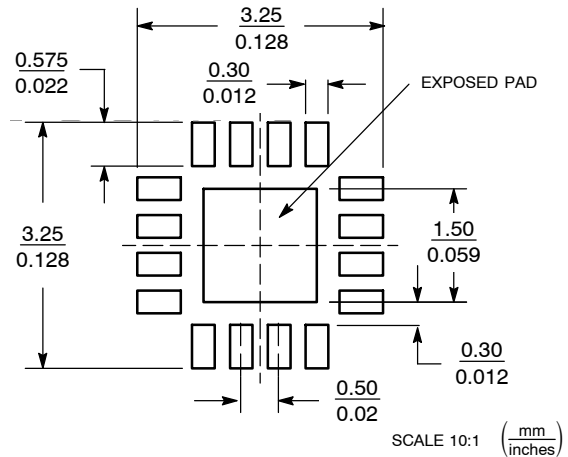

\*For additional information on our Pb-Free strategy and soldering details, please download the ON Semiconductor Soldering and Mounting Techniques Reference Manual, SOLDERRM/D.

ON Semiconductor and are registered trademarks of Semiconductor Components Industries, LLC (SCILLC). SCILLC reserves the right to make changes without further notice to any products herein. SCILLC makes no warranty, representation or guarantee regarding the suitability of its products for any particular purpose, nor does SCILLC assume any liability arising out of the application or use of any product or circuit, and specifically disclaims any and all liability, including without limitation special, consequential or incidental damages. "Typical" parameters which may be provided in SCILLC data sheets and/or specifications can and do vary in different applications and actual performance may vary over time. All operating parameters, including "Typicals" must be validated for each customer application by customer's technical experts. SCILLC does not convey any license under its patent rights nor the rights of others. SCILLC products are not designed, intended, or authorized for use as components in systems intended for surgical implant into the body, or other applications intended to support or sustain life, or for any other application in which the failure of the SCILLC product could create a situation where personal injury or death may occur. Should Buyer purchase or use SCILLC products for any such unintended or unauthorized application, Buyer shall indemnify and hold SCILLC and its officers, employees, subsidiaries, affiliates, and distributors harmless against all claims, costs, damages, and expenses, and reasonable attorney fees arising out of, directly or indirectly, any claim of personal injury or death associated with such unintended or unauthorized use, even if such claim alleges that SCILLC was negligent regarding the design or manufacture of the part. SCILLC is an Equal Opportunity/Affirmative Action Employer. This literature is subject to all applicable copyright laws and is not for resale in any manner.

**PUBLICATION ORDERING INFORMATION**

**LITERATURE FULFILLMENT:**  
Literature Distribution Center for ON Semiconductor  
P.O. Box 5163, Denver, Colorado 80217 USA  
**Phone:** 303-675-2175 or 800-344-3860 Toll Free USA/Canada  
**Fax:** 303-675-2176 or 800-344-3867 Toll Free USA/Canada  
**Email:** orderlit@onsemi.com

**N. American Technical Support:** 800-282-9855 Toll Free USA/Canada  
**Europe, Middle East and Africa Technical Support:**  
Phone: 421 33 790 2910  
**Japan Customer Focus Center**  
Phone: 81-3-5773-3850

**ON Semiconductor Website:** [www.onsemi.com](http://www.onsemi.com)  
**Order Literature:** <http://www.onsemi.com/orderlit>  
For additional information, please contact your local Sales Representative