

NB7L572

2.5V / 3.3V Differential 4:1 Mux Input to 1:2 LVPECL Clock/Data Fanout / Translator

Multi-Level Inputs w/ Internal Termination

The NB7L572 is a high performance differential 4:1 Clock/Data input multiplexer and a 1:2 LVPECL Clock/Data fanout buffer. The IN_x/\overline{IN}_x inputs includes internal $50\ \Omega$ termination resistors and will accept differential LVPECL, CML, or LVDS logic levels. The NB7L572 incorporates a pair of Select pins that will choose one of four differential inputs and will produce two identical LVPECL output copies of Clock or Data operating up to 7 GHz or 10 Gb/s, respectively. As such, NB7L572 is ideal for SONET, GigE, Fiber Channel, Backplane and other Clock/Data distribution applications.

The NB7L572 IN_x/\overline{IN}_x inputs, outputs and core logic are powered by a $2.5\ V \pm 5\%$ V or $3.3\ V \pm 10\%$ power supply. The two differential LVPECL outputs will swing 750 mV when externally terminated with a $50\ \Omega$ resistor to $V_{CC} - 2\ V$, and are optimized for low skew and minimal jitter.

The NB7L572 is offered in a low profile 5x5 mm 32-pin QFN Pb-free package. Application notes, models and support documentation are available at www.onsemi.com.

The NB7L572 is a member of the GigCom™ family of high performance clock products.

Features

- Input Data Rate > 10.7 Gb/s Typical
- Data Dependent Jitter < 15 ps
- Maximum Input Clock Frequency > 7 GHz Typical
- Random Clock Jitter < 0.8 ps RMS
- Low Skew 1:2 LVPECL Outputs, < 15 ps max
- 4:1 Multi-Level Mux Inputs, Accepts LVPECL, CML LVDS
- 150 ps Typical Propagation Delay
- 60 ps Typical Rise and Fall Times
- Differential LVPECL Outputs, 750 mV Peak-to-Peak, Typical
- Operating Range: $V_{CC} = 2.375\ V$ to $3.6\ V$
- Internal $50\ \Omega$ Input Termination Resistors
- V_{REFAC} Reference Output
- $-40^\circ C$ to $+85^\circ C$ Ambient Operating Temperature
- These are Pb-Free Devices



ON Semiconductor®

<http://onsemi.com>

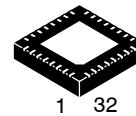

**QFN32
MN SUFFIX
CASE 488AM**

MARKING DIAGRAM*

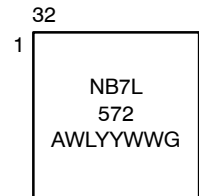

A = Assembly Site
WL = Wafer Lot
YY = Year
WW = Work Week
G = Pb-Free Package

*For additional marking information, refer to

Application Note AND8002/D.

www.BDTIC.com/ON

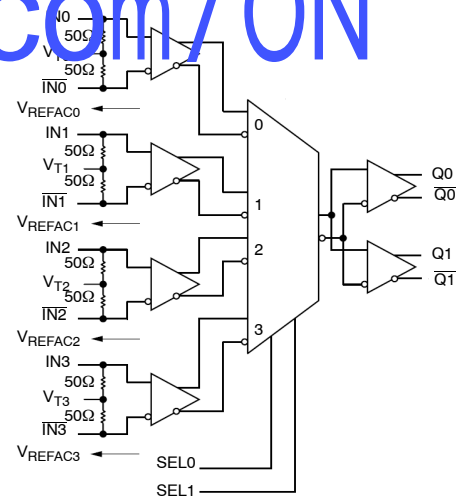

ORDERING INFORMATION

See detailed ordering and shipping information in the package dimensions section on page 8 of this data sheet.

NB7L572

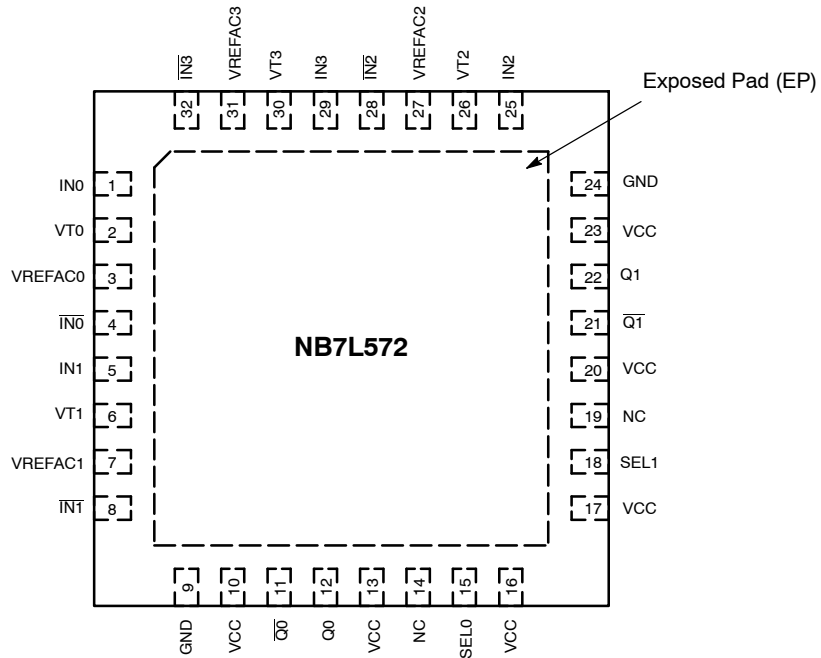

Figure 1. Pinout Configuration (Top View)

Table 1. INPUT SELECT FUNCTION TABLE

SEL1*	SEL0*	Clock / Data Input Selected
0	0	IN0 Input Selected
0	1	IN1 Input Selected
1	0	IN2 Input Selected
1	1	IN3 Input Selected

*Defaults HIGH when left open.

NB7L572

Table 2. PIN DESCRIPTION

Pin	Name	I/O	Description
1, 4 5, 8 25, 28 29, 32	IN0, $\overline{IN0}$ IN1, $\overline{IN1}$ IN2, $\overline{IN2}$ IN3, $\overline{IN3}$	LVPECL, CML, LVDS Input	Non-inverted, Inverted, Differential Clock or Data Inputs.
2, 6 26, 30	VT0, VT1 VT2, VT3		Internal 100 Ω Center-tapped Termination Pin for INx / \overline{INx}
15 18	SEL0 SEL1	LVTTTL/LVCMOS Input	Input Select pins, default HIGH when left open through a 28k- Ω pull-up resistor. Input logic threshold is $V_{CC}/2$. See Select Function, Table 1.
14, 19	NC	-	No Connect
10, 13, 16 17, 20, 23	VCC	-	Positive Supply Voltage. All VCC pins must be connected to the positive power supply for correct DC and AC operation.
11, 12 21, 22	$\overline{Q0}$, Q0 $\overline{Q1}$, Q1	LVPECL Output	Inverted, Non-inverted Differential Outputs.
9, 24	GND		Negative Supply Voltage, connected to Ground
3 7 27 31	VREFAC0 VREFAC1 VREFAC2 VREFAC3	-	Output Voltage Reference for Capacitor-Coupled Inputs
-	EP	-	The Exposed Pad (EP) on the QFN-32 package bottom is thermally connected to the die for improved heat transfer out of package. The exposed pad must be attached to a heat-sinking conduit. The pad is electrically connected to the die, and must be electrically connected to GND.

1. In the differential configuration when the input termination pins (VT0, VT1, VT2, VT3) are connected to a common termination voltage or left open, and if no signal is applied on INx / \overline{INx} input, then the device will be susceptible to self-oscillation.
2. All VCC, and GND pins must be externally connected to a power supply for proper operation.

www.BDTIC.com/ON

NB7L572

Table 3. ATTRIBUTES

Characteristic	Value
ESD Protection Human Body Model Machine Model	> 4 kV > 150 V
Input Pullup Resistor (R _{PU})	28 kΩ
Moisture Sensitivity (Note 3)	QFN32 Level 1
Flammability Rating Oxygen Index: 28 to 34	UL 94 V-0 @ 0.125 in
Transistor Count	205
Meets or exceeds JEDEC Spec EIA/JESD78 IC Latchup Test	

3. For additional information, see Application Note AND8003/D.

Table 4. MAXIMUM RATINGS

Symbol	Parameter	Condition 1	Condition 2	Rating	Unit
V _{CC}	Positive Power Supply	GND = 0 V		-0.5 to +4.0	V
V _{IN}	Positive Input Voltage	GND = 0 V		-0.5 to V _{CC} +0.5	V
V _{INPP}	Differential Input Voltage I _N - I _N			1.89	V
I _{out}	LVPECL Output Current	Continuous Surge		50 100	mA mA
I _{IN}	Input Current Through RT (50 Ω Resistor)			± 40	mA
T _A	Operating Temperature Range			-40 to +85	°C
T _{stg}	Storage Temperature Range			-65 to +150	°C
θ _{JA}	Thermal Resistance (Junction-to-Ambient) (Note 4)	0 lfpm 500 lfpm	QFN-32 QFN-32	31 27	°C/W °C/W
θ _{JC}	Thermal Resistance (Junction-to-Case) (Note 4)		QFN-32	12	°C/W
T _{sol}	Wave Solder	≤ 20 sec		265	°C

Stresses exceeding Maximum Ratings may damage the device. Maximum Ratings are stress ratings only. Functional operation above the Recommended Operating Conditions is not implied. Extended exposure to stresses above the Recommended Operating Conditions may affect device reliability.

4. JEDEC standard multilayer board – 2S2P (2 signal, 2 power) with 8 filled thermal vias under exposed pad.

NB7L572

Table 5. DC CHARACTERISTICS POSITIVE LVPECL OUTPUT $V_{CC} = 2.375\text{ V to }3.6\text{ V}$, $GND = 0\text{ V}$, $T_A = -40^\circ\text{C to }+85^\circ\text{C}$
(Note 6)

Symbol	Characteristic	Min	Typ	Max	Unit
--------	----------------	-----	-----	-----	------

POWER SUPPLY

V_{CC}	Power Supply Voltage	$V_{CC} = 2.5\text{ V}$ $V_{CC} = 3.3\text{ V}$	2.375 3.0	2.5 3.3	2.625 3.6	V
I_{CC}	Power Supply Current for V_{CC} (Inputs and Outputs Open)			90	110	mA

LVPECL OUTPUTS

V_{OH}	Output HIGH Voltage (Note 6)	$V_{CC} = 2.5\text{ V}$ $V_{CC} = 3.3\text{ V}$	$V_{CC} - 1145$ 1355 2155		$V_{CC} - 825$ 1675 2475	mV
V_{OL}	Output LOW Voltage (Note 6)	$V_{CC} = 2.5\text{ V}$ $V_{CC} = 3.3\text{ V}$	$V_{CC} - 2000$ 500 1300		$V_{CC} - 1500$ 1000 1800	mV

DIFFERENTIAL CLOCK INPUTS DRIVEN SINGLE-ENDED (Figures 4 & 6) (Note 7)

V_{IH}	Single-Ended Input HIGH Voltage		$V_{th} + 100$		V_{CC}	mV
V_{IL}	Single-Ended Input LOW Voltage		GND		$V_{th} - 100$	mV
V_{th}	Input Threshold Reference Voltage Range (Note 8)		1100		$V_{CC} - 100$	mV
V_{ISE}	Single-Ended Input Voltage ($V_{IH} - V_{IL}$)		200		1200	mV

VREFAC

V_{REF-AC}	Output Reference Voltage (100 μA Load)		$V_{CC} - 1500$		$V_{CC} - 1000$	mV
--------------	---	--	-----------------	--	-----------------	----

DIFFERENTIAL INPUTS DRIVEN DIFFERENTIALLY (Figures 5 & 7) (Note 9)

V_{IHD}	Differential Input HIGH Voltage (I_N, \bar{I}_N)		1200		V_{CC}	mV
V_{ILD}	Differential Input LOW Voltage (I_N, \bar{I}_N)		0		$V_{IHD} - 100$	mV
V_{ID}	Differential Input Voltage (I_N, \bar{I}_N) ($V_{IHD} - V_{ILD}$)		1000		1100	mV
V_{CMR}	Input Common Mode Range (Differential Configuration, Note 9) (Figure 8)		150		$V_{CC} - 50$	mV
I_{IH}	Input HIGH Current I_N/\bar{I}_N (V_T IN/ V_T \bar{I}_N Open)		-150		150	μA
I_{IL}	Input LOW Current I_N/\bar{I}_N (V_T IN/ V_T \bar{I}_N Open)		-150		150	μA

CONTROL INPUT (SELx Pin)

V_{IH}	Input HIGH Voltage for Control Pin		2.0		V_{CC}	V
V_{IL}	Input LOW Voltage for Control Pin		GND		0.8	V
I_{IH}	Input HIGH Current				40	μA
I_{IL}	Input LOW Current		-215		0	μA

TERMINATION RESISTORS

R_{TIN}	Internal Input Termination Resistor (Measured from I_N x to V_T x)		40	50	60	Ω
-----------	--	--	----	----	----	----------

NOTE: Device will meet the specifications after thermal equilibrium has been established when mounted in a test socket or printed circuit board with maintained transverse airflow greater than 500 lfm. Electrical parameters are guaranteed only over the declared operating temperature range. Functional operation of the device exceeding these conditions is not implied. Device specification limit values are applied individually under normal operating conditions and not valid simultaneously.

- Input and Output parameters vary 1:1 with V_{CC} .
- LVPECL outputs loaded with 50 Ω to $V_{CC} - 2\text{ V}$ for proper operation.
- V_{th} , V_{IH} , V_{IL} , and V_{ISE} parameters must be complied with simultaneously.
- V_{th} is applied to the complementary input when operating in single-ended mode.
- V_{IHD} , V_{ILD} , V_{ID} and V_{CMR} parameters must be complied with simultaneously.
- V_{CMR} min varies 1:1 with GND, V_{CMR} max varies 1:1 with V_{CC} . The V_{CMR} range is referenced to the most positive side of the differential input signal.

NB7L572

Table 6. AC CHARACTERISTICS $V_{CC} = 2.375\text{ V to }3.6\text{ V}$, $GND = 0\text{ V}$, $T_A = -40^\circ\text{C to }+85^\circ\text{C}$ (Note 11)

Symbol	Characteristic	Min	Typ	Max	Unit	
f_{MAX}	Maximum Input Clock Frequency $V_{OUT} \geq 400\text{ mV}$	7			GHz	
$f_{DATAMAX}$	Maximum Operating Data Rate NRZ, (PRBS23)	10.7			Gbps	
V_{OUTPP}	Output Voltage Amplitude (@ $V_{INPPmin}$) (Figure 2 & 9) (Note 12)		750		mV	
t_{PLH} , t_{PHL}	Propagation Delay to Differential Outputs Measured at Differential Cross-Point	@ 1 GHz INx/\bar{INx} to Qx/\bar{Qx} (Figure 9) @ 50 MHz $SELx$ to Qx (Figure 10)	215 100		390 500	ps
$t_{PD\ Tempco}$	Differential Propagation Delay Temperature Coefficient		115		fs/ $^\circ\text{C}$	
t_{skew}	Output – Output skew (within device) (Note 13) Device – Device skew (tpd max – tpd min)		0	15 100	ps	
t_{DC}	Output Clock Duty Cycle (Reference Duty Cycle = 50%)	45	50	55	%	
t_{JITTER}	Additive Random Clock Jitter, RJ(RMS) (Note 14) Data Dependent Jitter, DDJ (Note 15)	$f_{in} = 5.0\text{ GHz}$ $f_{in} = 7.0\text{ GHz}$ 6.5 Gbps 10 Gbps	0.5 0.5	0.8 0.8 15 15	ps rms ps pk-pk	
V_{INPP}	Input Voltage Swing (Differential Configuration) (Note 16)	100		1200	mV	
t_r, t_f	Output Rise/Fall Times @ 1 GHz; (20% – 80%), $V_{IN} = 800\text{ mV } Q, \bar{Q}$	35	60	110	ps	

NOTE: Device will meet the specifications after thermal equilibrium has been established when mounted in a test socket or printed circuit board with maintained transverse airflow greater than 500 lfm. Electrical parameters are guaranteed only over the declared operating temperature range. Functional operation of the device exceeding these conditions is not implied. Device specification limit values are applied individually under normal operating conditions and not valid simultaneously.

11. Measured using a 100 mVpk-pk source, 50% duty cycle clock source. All output loading with external $50\ \Omega$ to $V_{CC} - 2\text{ V}$. Input edge rates 40 ps (20% – 80%).
12. Output voltage swing is a single-ended measurement operating in differential mode.
13. Skew is measured between outputs under identical transitions and conditions. Duty cycle skew is defined only for differential operation when the delays are measured from cross-point of the inputs to the cross-point of the outputs.
14. Additive RMS jitter with 50% duty cycle clock signal.
15. Additive Peak-to-Peak data dependent jitter with input NRZ data at K28.5.
16. Input voltage swing is a single-ended measurement operating in differential mode.

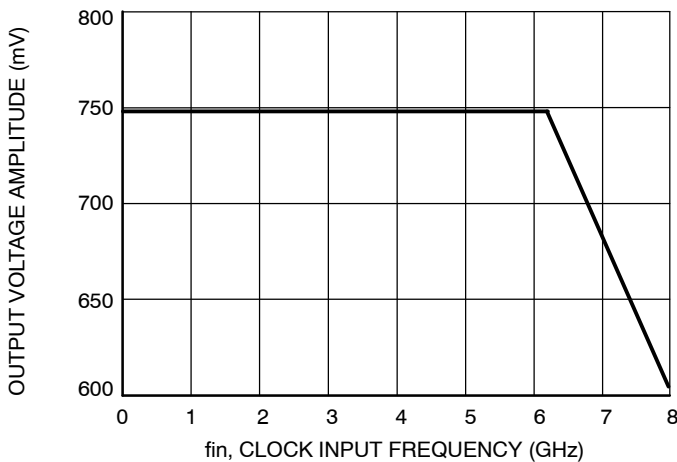

Figure 2. CLOCK Output Voltage Amplitude (V_{OUTPP}) / RMS Jitter vs. Input Frequency (f_{in}) at Ambient Temperature (typical)

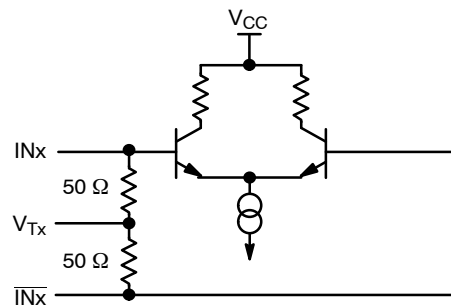

Figure 3. Input Structure

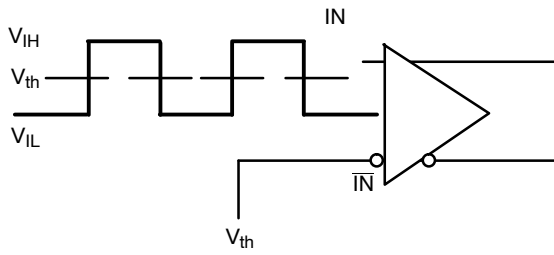

Figure 4. Differential Input Driven Single-Ended

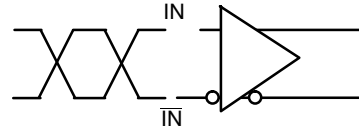

Figure 5. Differential Inputs Driven Differentially

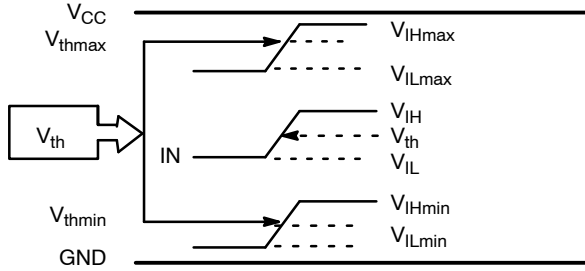

Figure 6. V_{th} Diagram

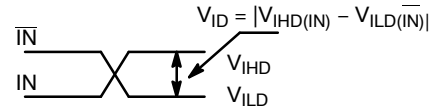

Figure 7. Differential Inputs Driven Differentially

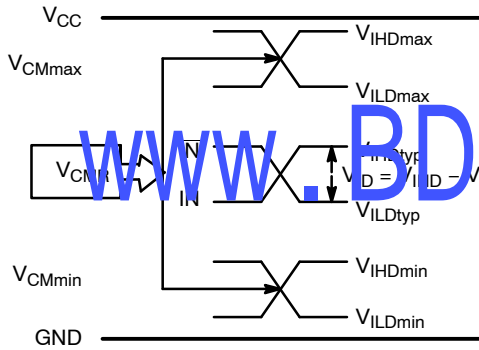

Figure 8. V_{CMR} Diagram

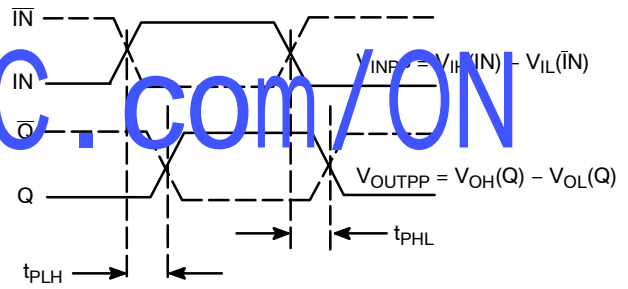

Figure 9. AC Reference Measurement

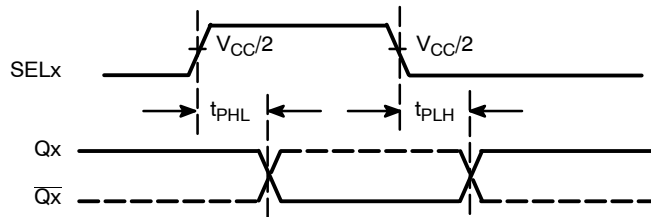

Figure 10. SELx to Qx Timing Diagram

NB7L572

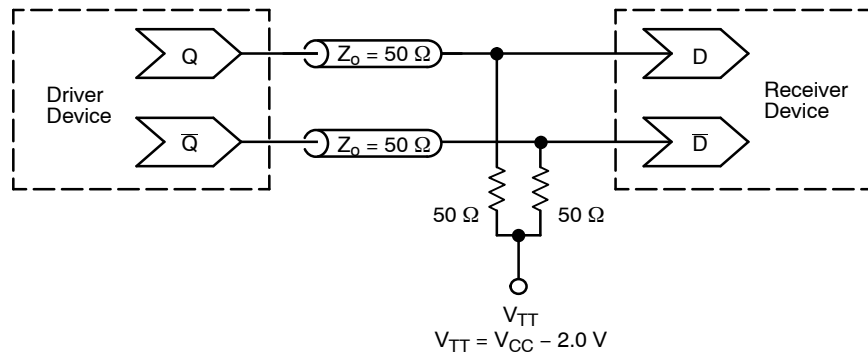

Figure 11. Typical Termination for Output Driver and Device Evaluation
(See Application Note AND8020/D – Termination of ECL Logic Devices.)

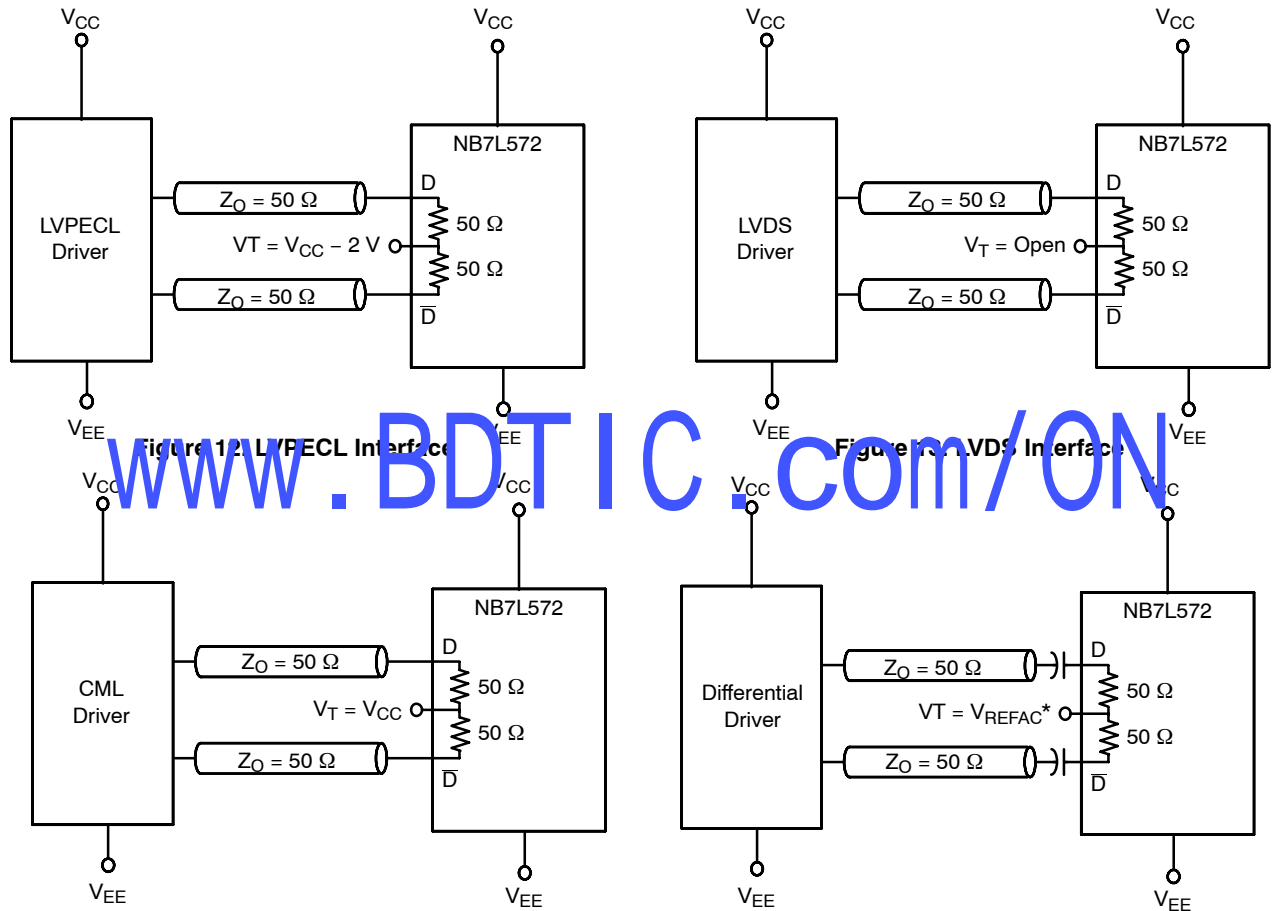

Figure 14. Standard 50 Ω Load CML Interface

Figure 15. Capacitor-Coupled Differential Interface
(VT Connected to V_{REFAC})

* V_{REFAC} bypassed to ground with a 0.01 μF capacitor

ORDERING INFORMATION

Device	Package	Shipping†
NB7L572MNG	QFN32 (Pb-Free)	79 Units / Rail
NB7L572MNR4G	QFN32 (Pb-Free)	1000 / Tape & Reel

†For information on tape and reel specifications, including part orientation and tape sizes, please refer to our Tape and Reel Packaging Specifications Brochure, BRD8011/D.

NB7L572

PACKAGE DIMENSIONS

QFN32 5x5, 0.5P
CASE 488AM-01
ISSUE 0

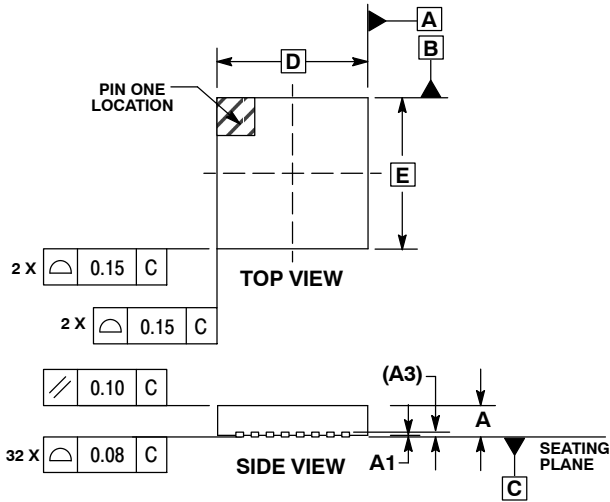

NOTES:

1. DIMENSIONS AND TOLERANCING PER ASME Y14.5M, 1994.
2. CONTROLLING DIMENSION: MILLIMETERS.
3. DIMENSION b APPLIES TO PLATED TERMINAL AND IS MEASURED BETWEEN 0.25 AND 0.30 MM TERMINAL
4. COPLANARITY APPLIES TO THE EXPOSED PAD AS WELL AS THE TERMINALS.

DIM	MILLIMETERS		
	MIN	NOM	MAX
A	0.800	0.900	1.000
A1	0.000	0.025	0.050
A3	0.200 REF		
b	0.180	0.250	0.300
D	5.00 BSC		
D2	2.950	3.100	3.250
E	5.00 BSC		
E2	2.950	3.100	3.250
e	0.500 BSC		
K	0.200	---	---
L	0.300	0.400	0.500

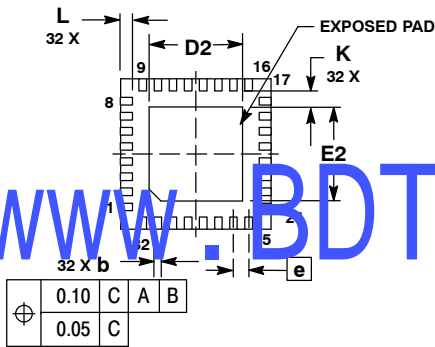

BOTTOM VIEW

SOLDERING FOOTPRINT*

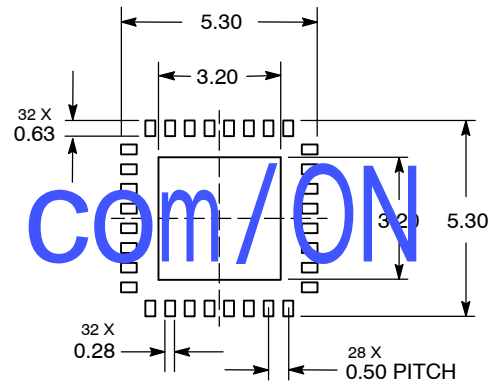

*For additional information on our Pb-Free strategy and soldering details, please download the ON Semiconductor Soldering and Mounting Techniques Reference Manual, SOLDERRM/D.

ON Semiconductor and are registered trademarks of Semiconductor Components Industries, LLC (SCILLC). SCILLC reserves the right to make changes without further notice to any products herein. SCILLC makes no warranty, representation or guarantee regarding the suitability of its products for any particular purpose, nor does SCILLC assume any liability arising out of the application or use of any product or circuit, and specifically disclaims any and all liability, including without limitation special, consequential or incidental damages. "Typical" parameters which may be provided in SCILLC data sheets and/or specifications can and do vary in different applications and actual performance may vary over time. All operating parameters, including "Typicals" must be validated for each customer application by customer's technical experts. SCILLC does not convey any license under its patent rights nor the rights of others. SCILLC products are not designed, intended, or authorized for use as components in systems intended for surgical implant into the body, or other applications intended to support or sustain life, or for any other application in which the failure of the SCILLC product could create a situation where personal injury or death may occur. Should Buyer purchase or use SCILLC products for any such unintended or unauthorized application, Buyer shall indemnify and hold SCILLC and its officers, employees, subsidiaries, affiliates, and distributors harmless against all claims, costs, damages, and expenses, and reasonable attorney fees arising out of, directly or indirectly, any claim of personal injury or death associated with such unintended or unauthorized use, even if such claim alleges that SCILLC was negligent regarding the design or manufacture of the part. SCILLC is an Equal Opportunity/Affirmative Action Employer. This literature is subject to all applicable copyright laws and is not for resale in any manner.

PUBLICATION ORDERING INFORMATION

LITERATURE FULFILLMENT:
Literature Distribution Center for ON Semiconductor
P.O. Box 5163, Denver, Colorado 80217 USA
Phone: 303-675-2175 or 800-344-3860 Toll Free USA/Canada
Fax: 303-675-2176 or 800-344-3867 Toll Free USA/Canada
Email: orderlit@onsemi.com

N. American Technical Support: 800-282-9855 Toll Free USA/Canada
Europe, Middle East and Africa Technical Support:
Phone: 421 33 790 2910
Japan Customer Focus Center
Phone: 81-3-5773-3850

ON Semiconductor Website: www.onsemi.com
Order Literature: <http://www.onsemi.com/orderlit>

For additional information, please contact your local Sales Representative