



**Product Description**

The D8740200GTH is a Hybrid Power Doubler amplifier module. The part employs GaAS die and is operated from 40MHz to 870MHz. It provides excellent linearity and superior return loss performance with low noise and optimal reliability.

**Features**

- Excellent Linearity
- Superior Return Loss Performance
- Extremely Low Distortion
- Optimal Reliability
- Low Noise
- Unconditionally Stable Under All Terminations
- 20.5 dB Min. Gain at 870 MHz
- 440 mA Max. at 24 VDC

**Applications**

- 40 MHz to 870 MHz CATV Amplifier Systems

**Optimum Technology Matching® Applied**

- GaAs HBT
- GaAs MESFET
- InGaP HBT
- SiGe BiCMOS
- Si BiCMOS
- SiGe HBT
- GaAs pHEMT
- Si CMOS
- Si BJT
- GaN HEMT
- RF MEMS

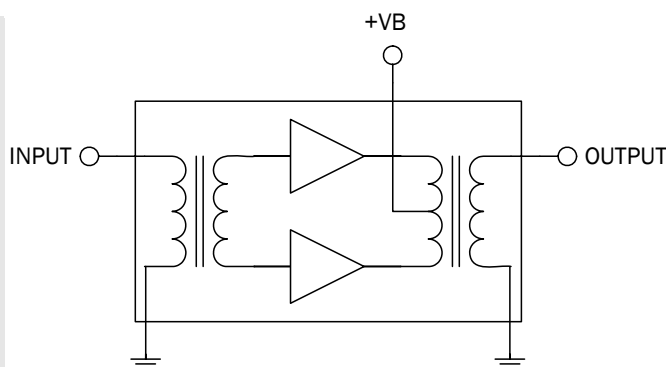

Parameter	Specification			Unit	Condition
	Min.	Typ.	Max.		
<b>Overall</b>					$V_B = 24V; T_{MB} = 30^\circ C; Z_S = Z_L = 75\Omega$
Power Gain	19.5	20.0	20.5	dB	f=50 MHz
	20.5	21.0	21.5	dB	f=870 MHz
Slope [1]	0.6	1.0	1.4	dB	f=40 MHz to 870 MHz
Flatness of Frequency Response			0.6	dB	f=40 MHz to 870 MHz (Peak to Valley)
Input Return Loss	20.0			dB	f=40 MHz to 320 MHz
	19.0			dB	f=320 MHz to 640 MHz
	17.0			dB	f=640 MHz to 870 MHz
Output Return Loss	20.0			dB	f=40 MHz to 320 MHz
	19.0			dB	f=320 MHz to 640 MHz
	18.0			dB	f=640 MHz to 870 MHz
Noise Figure		5.5	6.5	dB	f=50 MHz to 870 MHz
Total Current Consumption (DC)		420.0	440.0	mA	

1. The slope is defined as the difference between the gain at the start frequency and the gain at the stop frequency.

## Absolute Maximum Ratings

Parameter	Rating	Unit
RF Input Voltage (single tone)	75	dBmV
DC Supply Over-Voltage (5 minutes)	30	V
Storage Temperature	-40 to +100	°C
Operating Mounting Base Temperature	-30 to +100	°C



**Caution!** ESD sensitive device.

Exceeding any one or a combination of the Absolute Maximum Rating conditions may cause permanent damage to the device. Extended application of Absolute Maximum Rating conditions to the device may reduce device reliability. Specified typical performance or functional operation of the device under Absolute Maximum Rating conditions is not implied.

RoHS status based on EU Directive 2002/95/EC (at time of this document revision).

The information in this publication is believed to be accurate and reliable. However, no responsibility is assumed by RF Micro Devices, Inc. ("RFMD") for its use, nor for any infringement of patents, or other rights of third parties, resulting from its use. No license is granted by implication or otherwise under any patent or patent rights of RFMD. RFMD reserves the right to change component circuitry, recommended application circuitry and specifications at any time without prior notice.

Parameter	Specification			Unit	Condition
	Min.	Typ.	Max.		
<b>Distortion data 40MHz to 870MHz</b>					$V_B = 24V; T_{MB} = 30^\circ C; Z_S = Z_L = 75\Omega$
CTB		-68	-66	dBc	79 ch. flat; $V_O = 48\text{dBmV}^{[2]}$
		-62	-60	dBc	112 ch. flat; $V_O = 48\text{dBmV}^{[3]}$
		-58	-56	dBc	132 ch. flat; $V_O = 48\text{dBmV}^{[4]}$
		-66	-64	dBc	79 ch. 7 dB tilted; $V_O = 53\text{dBmV}$ at 550MHz <sup>[5]</sup>
		-60	-58	dBc	112 ch. 10dB tilted; $V_O = 54\text{dBmV}$ at 750MHz <sup>[6]</sup>
XMOD		-62	-60	dBc	79 ch. flat; $V_O = 48\text{dBmV}^{[2]}$
		-59	-57	dBc	112 ch. flat; $V_O = 48\text{dBmV}^{[3]}$
		-57	-55	dBc	132 ch. flat; $V_O = 48\text{dBmV}^{[4]}$
		-60	-58	dBc	79 ch. 7 dB tilted; $V_O = 53\text{dBmV}$ at 550MHz <sup>[5]</sup>
		-53	-51	dBc	112 ch. 10dB tilted; $V_O = 54\text{dBmV}$ at 750MHz <sup>[6]</sup>
CSO		-70	-68	dBc	79 ch. flat; $V_O = 48\text{dBmV}^{[2]}$
		-66	-64	dBc	112 ch. flat; $V_O = 48\text{dBmV}^{[3]}$
		-64	-62	dBc	132 ch. flat; $V_O = 48\text{dBmV}^{[4]}$
		-69	-67	dBc	79 ch. 7 dB tilted; $V_O = 53\text{dBmV}$ at 550MHz <sup>[5]</sup>
		-65	-63	dBc	112 ch. 10dB tilted; $V_O = 54\text{dBmV}$ at 750MHz <sup>[6]</sup>

2. 79 channels, NTSC frequency raster; 55.25MHz to 547.25MHz, +48dBmV flat output level.

3. 112 channels, NTSC frequency raster; 55.25MHz to 745.25MHz, +48dBmV flat output level.

4. 132 channels, NTSC frequency raster; 55.25MHz to 865.25MHz, +48dBmV flat output level.

5. 79 channels, NTSC frequency raster; 55.25MHz to 547.25MHz, +46dBmV to +53dBmV tilted output level.

6. 112 channels, NTSC frequency raster; 55.25MHz to 745.25MHz, +44dBmV to +54dBmV tilted output level.

Composite Second Order (CSO) - The CSO parameter (both sum and difference products) is defined by the NCTA.

Composite Triple Beat (CTB) - The CTB parameter is defined by the NCTA.

Cross Modulation (XMOD) - Cross modulation (XMOD) is measured at baseband (selective voltmeter method), referenced to 100% modulation of the carrier being tested.

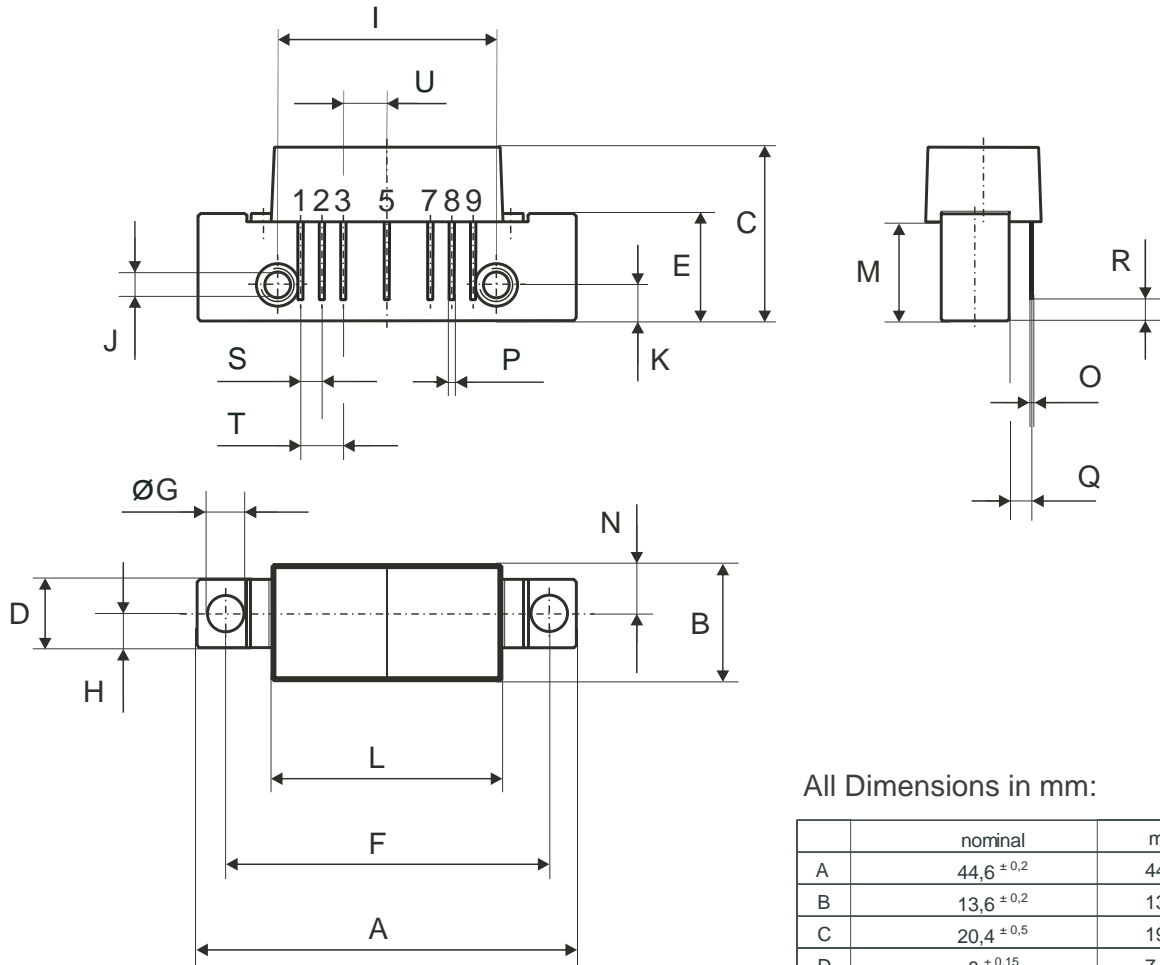

All Dimensions in mm:

	nominal	min	max
A	44,6 ± 0,2	44,4	44,8
B	13,6 ± 0,2	13,4	13,8
C	20,4 ± 0,5	19,9	20,9
D	8 ± 0,15	7,85	8,15
E	12,6 ± 0,15	12,45	12,75
F	38,1 ± 0,2	37,9	38,3
G	4 +0,2 / -0,05	3,95	4,2
H	4 ± 0,2	3,8	4,2
I	25,4 ± 0,2	25,2	25,6
J	UNC 6-32	-	-
K	4,2 ± 0,2	4,0	4,4
L	27,2 ± 0,2	27,0	27,4
M	11,6 ± 0,5	11,1	12,1
N	5,8 ± 0,4	5,4	6,2
O	0,25 ± 0,02	0,23	0,27
P	0,45 ± 0,03	0,42	0,48
Q	2,54 ± 0,3	2,24	2,84
R	2,54 ± 0,5	2,04	3,04
S	2,54 ± 0,25	2,29	2,79
T	5,08 ± 0,25	4,83	5,33
U	5,08 ± 0,25	4,83	5,33

Pinning:

	1	2	3	4	5	6	7	8	9
	INPUT	GND	GND		+VB		GND	GND	OUTPUT

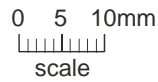

Notes:

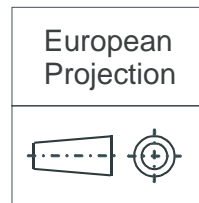

# D8740200GTH



rfmd.com