



Features

- Broadband Performance
Low Frequency to 3.5GHz
- Very Low Insertion Loss
0.25dB Typ at 0.90GHz
0.45dB Typ at 1.90GHz
- Excellent Linearity Performance
IIP2 Typ 109dBm at 0.90GHz
IIP2 Typ 105dBm at 1.90GHz
- 1.6V Capable for Low Power Applications
- Lead Free and RoHS Compliant

Applications

- Cellular Handset Applications
- IEEE 802.11b/g WLAN Applications
- Multi-mode GSM, WCDMA Applications
- WLAN Applications
- SAW Filter Switching

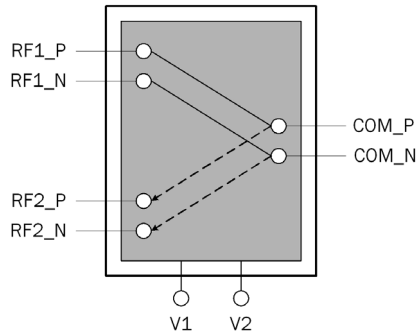

Functional Block Diagram

Product Description

The RF1226 is a single-pole double-throw (SPDT) differential switch designed for general purpose switching applications which require very low insertion loss and low power signal routing applications. Excellent performance matching between the two SPDT devices makes the RF1226 particularly suited to differential SAW filter switching. The RF1226 features low insertion loss, high linearity, and very good harmonic characteristics. The switch is operable from 1.6V to 3.6V control voltage. It is fabricated with 0.5um GaAs pHEMT process and is packaged in a very compact 2mmx2mm 12-pin leadless QFN package.

Ordering Information

RF1226 Broadband Medium Power Differential SPDT Switch
 RF1226PCBA-410 Fully Assembled Evaluation Board

Optimum Technology Matching® Applied

- | | | | |
|--------------------------------------|--------------------------------------|--|-----------------------------------|
| <input type="checkbox"/> GaAs HBT | <input type="checkbox"/> SiGe BiCMOS | <input checked="" type="checkbox"/> GaAs pHEMT | <input type="checkbox"/> GaN HEMT |
| <input type="checkbox"/> GaAs MESFET | <input type="checkbox"/> Si BiCMOS | <input type="checkbox"/> Si CMOS | <input type="checkbox"/> RF MEMS |
| <input type="checkbox"/> InGaP HBT | <input type="checkbox"/> SiGe HBT | <input type="checkbox"/> Si BJT | <input type="checkbox"/> LDMOS |

RF MICRO DEVICES®, RFMD®, Optimum Technology Matching®, Enabling Wireless Connectivity™, PowerStar®, POLARIS™, TOTAL RADIO™ and UltimateBlue™ are trademarks of RFMD, LLC. BLUETOOTH is a trademark owned by Bluetooth SIG, Inc., U.S.A. and licensed for use by RFMD. All other trade names, trademarks and registered trademarks are the property of their respective owners. ©2006, RF Micro Devices, Inc.

Absolute Maximum Ratings

Parameter	Rating	Unit
Voltage	6.0	V
Maximum Input Power (0.6GHz to 2.5GHz), RF1, RF2	+28	dBm
Operating Temperature	-30 to +85	°C
Storage Temperature	-65 to +100	°C



Caution! ESD sensitive device.

Exceeding any one or a combination of the Absolute Maximum Rating conditions may cause permanent damage to the device. Extended application of Absolute Maximum Rating conditions to the device may reduce device reliability. Specified typical performance or functional operation of the device under Absolute Maximum Rating conditions is not implied.

RoHS status based on EU Directive 2002/95/EC (at time of this document revision).

The information in this publication is believed to be accurate and reliable. However, no responsibility is assumed by RF Micro Devices, Inc. ("RFMD") for its use, nor for any infringement of patents, or other rights of third parties, resulting from its use. No license is granted by implication or otherwise under any patent or patent rights of RFMD. RFMD reserves the right to change component circuitry, recommended application circuitry and specifications at any time without prior notice.

Parameter	Specification			Unit	Condition
	Min.	Typ.	Max.		
Overall - $V_{\text{control_high}} = 2.6\text{V}$					$V_{\text{RF1}}, V_{\text{RF2}} = \text{High} = 2.6\text{V}$, $V_{\text{RF1}} = V_{\text{RF2}} = \text{Low} = 0\text{V}$, Temp = 25 °C
Operating Frequency	600		2500	MHz	
Insertion Loss					
RF1_P, RF2_P - COM_P RF1_N, RF2_N - COM_N		0.25	0.45	dB	824MHz to 960MHz
		0.45	0.65	dB	1850MHz to 1990MHz
		0.45		dB	2170MHz to 2500MHz
		0.45		dB	2500MHz to 3500MHz
Isolation					
RF1_P, RF2_P - COM_P RF1_N, RF2_N - COM_N	24	27		dB	824MHz to 960MHz
	18	21		dB	1850MHz to 1990MHz
	16	19		dB	2170MHz to 2500MHz
	14	17		dB	2500MHz to 3500MHz
RF1_N - RF2_N RF1PN - RF2_P	24	27		dB	824MHz to 960MHz
	18	21		dB	1850MHz to 1990MHz
	16	19		dB	2170MHz to 2500MHz
	14	17		dB	2500MHz to 3500MHz
RF Port Return Loss		1.5:1			500MHz to 3000MHz
Second Harmonics	62	96		dBc	$P_{\text{IN}} = +16\text{dBm}$, 880MHz
	62	93		dBc	$P_{\text{IN}} = +16\text{dBm}$, 1880MHz
	62	90		dBc	$P_{\text{IN}} = +16\text{dBm}$, 2500MHz
Third Harmonics	62	98		dBc	$P_{\text{IN}} = +16\text{dBm}$, 880MHz
	62	98		dBc	$P_{\text{IN}} = +16\text{dBm}$, 1880MHz
	62	95		dBc	$P_{\text{IN}} = +16\text{dBm}$, 2500MHz

Parameter	Specification			Unit	Condition
	Min.	Typ.	Max.		
Overall - $V_{\text{control_high}} = 2.6\text{V}$ (continued)					$V_{\text{RF1}}, V_{\text{RF2}} = \text{High} = 2.6\text{V}$, $V_{\text{RF1}} = V_{\text{RF2}} = \text{Low} = 0\text{V}$, Temp = 25 °C
IIP2					
RF1, RF2 - COM (Cell)	105	109		dBm	Tone 1: 836.5MHz @ 16dBm, Tone 2: 791.5MHz @ -20dBm RX Freq: 881.5MHz
RF1, RF2 - COM (IMT)	102	106		dBm	Tone 1: 1950MHz @ 16dBm, Tone 2: 1760MHz @ -20dBm RX Freq: 2140MHz
RF1, RF2 - COM (AWS)	101	106		dBm	Tone 1: 1710MHz @ 16dBm, Tone 2: 3820MHz @ -20dBm RX Freq: 2110MHz
RF1, RF2 - COM (PCS)	102	107		dBm	Tone 1: 1910MHz @ 16dBm, Tone 2: 3900MHz @ -20dBm RX Freq: 1990MHz
Triple Beat Ratio (TBR)		100		dBc	VSWR=2:1, TX1=TX2=11.5dBm Cell/AWS/PCS
0.1dB Compression (PO.1dB)		26		dBm	500MHz to 3000MHz
Switching Speed		400		ns	50% control to 10% RF OFF
		260		ns	50% control to 90% RF ON

Parameter	Specification			Unit	Condition
	Min.	Typ.	Max.		
Overall - $V_{\text{control_high}} = 1.8\text{V}$					$V_1, V_2 = \text{High} = 1.8\text{V}$, $V_1 = V_2 = \text{Low} = 0\text{V}$, Temp = 25 °C
Operating Frequency	600		3500	MHz	
Insertion Loss					
RF1_P, RF2_P - COM_P		0.25	0.45	dB	824MHz to 960MHz
RF1_N, RF2_N - COM_N		0.40	0.65	dB	1850MHz to 1990MHz
		0.45		dB	2170MHz to 2500MHz
		0.45		dB	2500MHz to 3500MHz
Isolation					
RF1_P, RF2_P - COM_P	24	26		dB	824MHz to 960MHz
RF1_N, RF2_N - COM_N	18	20		dB	1850MHz to 1990MHz
	16	18		dB	2170MHz to 2500MHz
	14	17		dB	2500MHz to 3500MHz
RF1_N - RF2_N	24	27		dB	824MHz to 960MHz
RF1PN - RF2_P	18	20		dB	1850MHz to 1990MHz
	16	19		dB	2170MHz to 2500MHz
	14	17		dB	2500MHz to 3500MHz
Return Loss		1.5:1			500MHz to 3000MHz
P0.1dB Compression		20		dBm	500MHz to 3000MHz
Switching Speed		1.25		μs	50% control to 10% RF OFF
		0.66		μs	50% control to 90% RF ON
DC Characteristics					
DC Supply	1.6	2.6	3.6	V	VRF1, VRF2 (H)
	0		0.4	V	VRF1, VRF2 (L)
Control Current		0.4	1.0	μA	$P_{IN} = 15\text{dBm}$

Control Logic

	Control Signals		Signal Paths	
	V1	V2	RF1_P - COM_P, RF1_N - COM_N	RF2_P - COM_P, RF2_N - COM_N
Valid States	1	0	ON	OFF
	0	1	OFF	ON
Invalid States	0	0	Indeterminate State*	
	1	1	Indeterminate State*	

0: Logic level low, 0V~0.4V

1: Logic level high, 1.6V~3.6V

Note: In indeterminate states, both signal paths are ON with degraded performance.

Pin	Function	Description
1	RF1_P	Positive RF Port 1.
2	RF1_N	Negative RF Port 1.
3	V1	Voltage Control 1.
4	NC	Not connected.
5	NC	Not connected.
6	NC	Not connected.
7	V2	Voltage Control 2.
8	RF2_N	Negative RF Port 2.
9	RF2_P	Positive RF Port 2.
10	COM_P	Positive Common Port.
11	GND	Ground.
12	COM_N	Negative Common Port.

Package Drawing

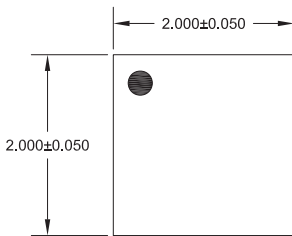

TOP VIEW

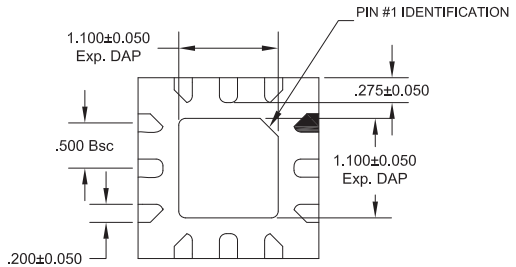

BOTTOM VIEW

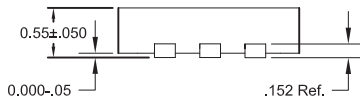

SIDE VIEW

Notes:

1) Pin 1 Shaded Area

Evaluation Board Schematic

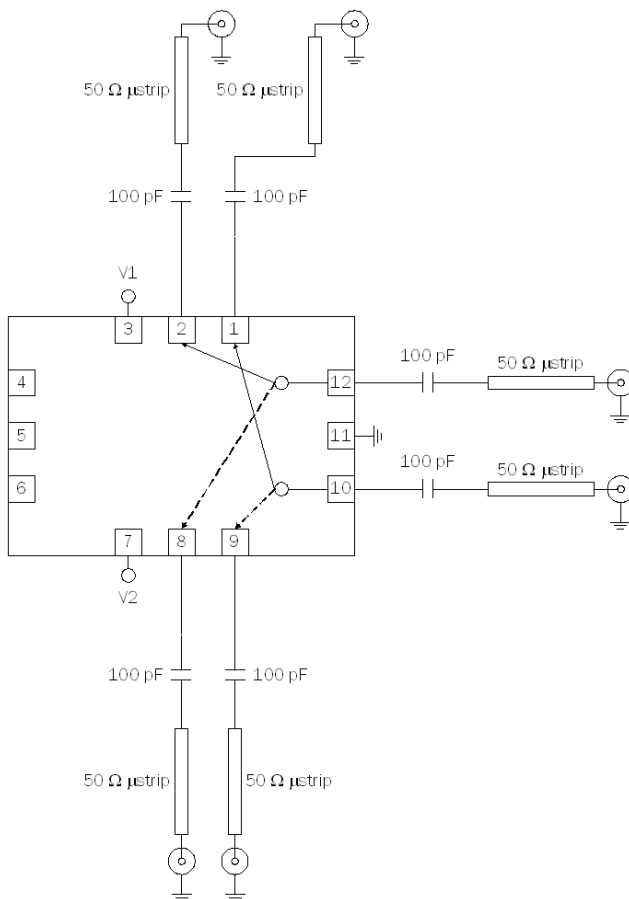

Typical Performance

Max Insertion Loss
(Temp=25°C, VRF=1.8V)

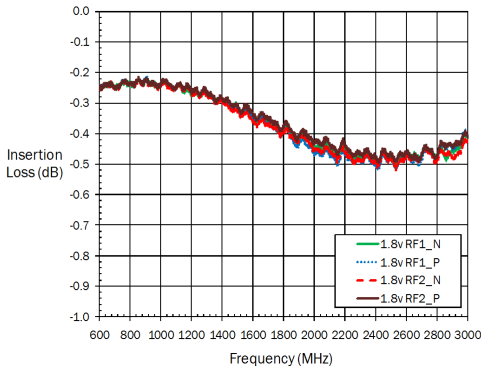

RF1226 Max Insertion Loss
(Temp = 25°C, VRF=2.6V)

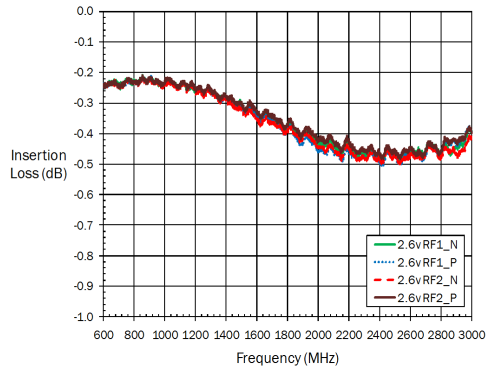

Isolation
(Temp=25°C, VRF=1.8V)

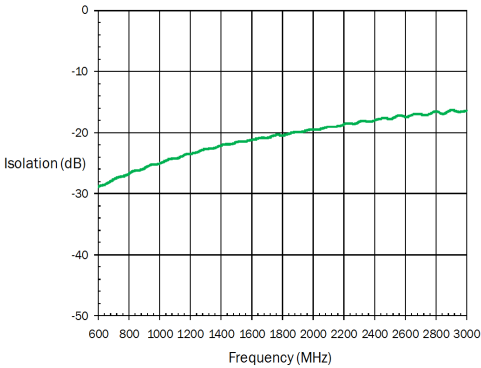

Isolation
(Temp=25°C, VRF=2.6V)

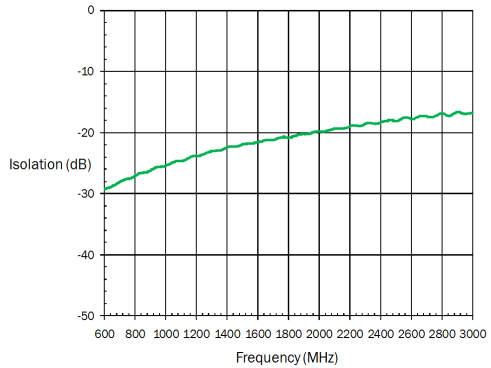

Max Ant Port Return Loss
(Temp=25°C, VRF=1.8V)

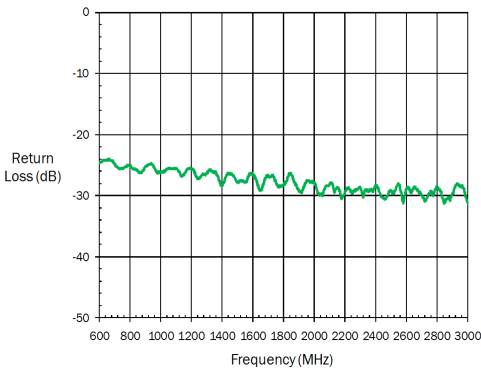

Max Ant Port Return Loss
(Temp=25°C, VRF=2.6V)

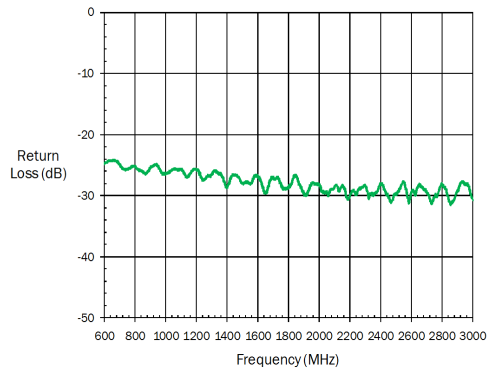

Typical Performance

Harmonics
(Temp=25°C, Fo=1880MHz, VRF=1.8V)

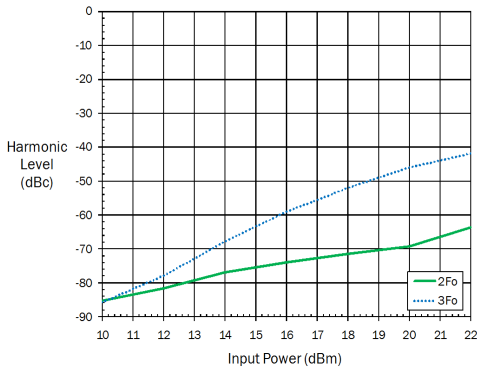

Harmonics
(Temp=25°C, Fo=1880MHz, VRF=2.6V)

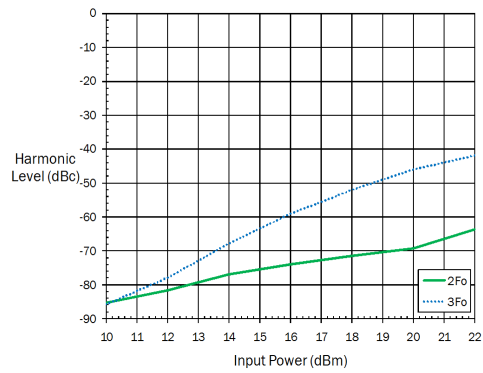

Output Power versus Input Power
(Temperature=25°C, VRF=1.8V)

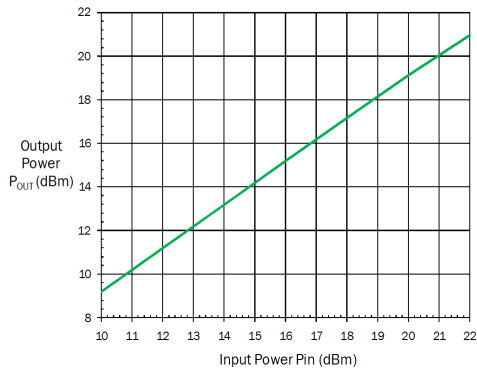

Output Power versus Input Power
(Temperature=25°C, VRF=2.6V)

