

4M x 16bit CMOS Dynamic RAM with Fast Page Mode

DESCRIPTION

This is a family of 4,194,304 x 16 bit Fast Page Mode CMOS DRAMs. Fast Page Mode offers high speed random access of memory cells within the same row. Refresh cycle(4K Ref. or 8K Ref.), access time (-45, -50 or -60), power consumption(Normal or Low power) are optional features of this family. All of this family have $\overline{\text{CAS}}$ -before- $\overline{\text{RAS}}$ refresh, $\overline{\text{RAS}}$ -only refresh and Hidden refresh capabilities. Furthermore, Self-refresh operation is available in L-version. This 4Mx16 Fast Page Mode DRAM family is fabricated using Samsung's advanced CMOS process to realize high band-width, low power consumption and high reliability.

FEATURES

• **Part Identification**

- K4F661612C-TC/L(3.3V, 8K Ref.)
- K4F641612C-TC/L(3.3V, 4K Ref.)

• **Active Power Dissipation**

Unit : mW

Speed	8K	4K
-45	324	468
-50	288	432
-60	252	396

• **Refresh Cycles**

Part NO.	Refresh cycle	Refresh time	
		Normal	L-ver
K4F661612C*	8K	64ms	128ms
K4F641612C	4K		

* Access mode & $\overline{\text{RAS}}$ only refresh mode : 8K cycle/64ms(Normal), 8K cycle/128ms(L-ver.)
 $\overline{\text{CAS}}$ -before- $\overline{\text{RAS}}$ & Hidden refresh mode : 4K cycle/64ms(Normal), 4K cycle/128ms(L-ver.)

• **Performance Range**

Speed	t _{TRC}	t _{CAC}	t _{RC}	t _{PC}
-45	45ns	12ns	80ns	31ns
-50	50ns	13ns	90ns	35ns
-60	60ns	15ns	110ns	40ns

- Fast Page Mode operation
- $\overline{2\text{CAS}}$ Byte/Word Read/Write operation
- $\overline{\text{CAS}}$ -before- $\overline{\text{RAS}}$ refresh capability
- $\overline{\text{RAS}}$ -only and Hidden refresh capability
- Self-refresh capability (L-ver only)
- Fast parallel test mode capability
- LVTTTL(3.3V) compatible inputs and outputs
- Early Write or output enable controlled write
- JEDEC Standard pinout
- Available in Plastic TSOP(II) packages
- +3.3V±0.3V power supply

FUNCTIONAL BLOCK DIAGRAM

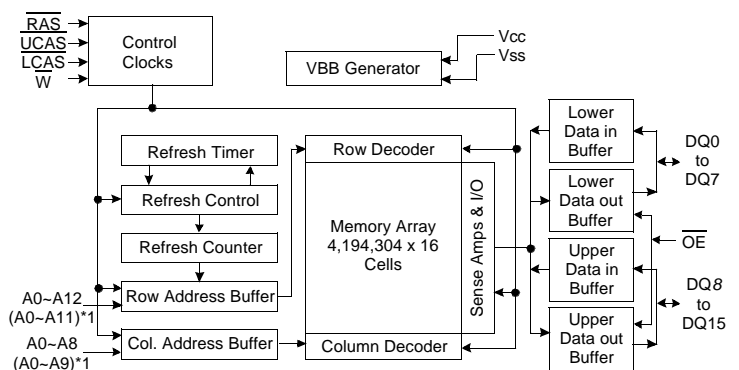

Note) *1 : 4K Refresh

SAMSUNG ELECTRONICS CO., LTD. reserves the right to change products and specifications without notice.



PIN CONFIGURATION (Top Views)

- K4F661612C-T
- K4F641612C-T

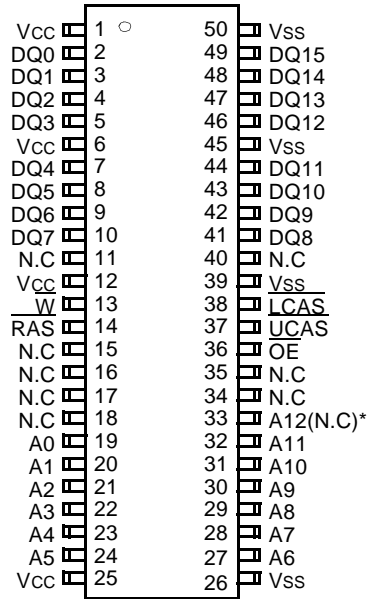

(400mil TSOP(II))

*(N.C) : N.C for 4K Refresh Product

Pin Name	Pin function
A0 - A12	Address Inputs(8K Product)
A0 - A11	Address Inputs(4K Product)
DQ0 - 15	Data In/Out
Vss	Ground
\overline{RAS}	Row Address Strobe
\overline{UCAS}	Upper Column Address Strobe
\overline{LCAS}	Lower Column Address Strobe
\overline{W}	Read/Write Input
OE	Data Output Enable
Vcc	Power(+3.3V)
N.C	No Connection

ABSOLUTE MAXIMUM RATINGS

Parameter	Symbol	Rating	Units
Voltage on any pin relative to Vss	V _{IN} , V _{OUT}	-0.5 to +4.6	V
Voltage on Vcc supply relative to Vss	V _{CC}	-0.5 to +4.6	V
Storage Temperature	T _{stg}	-55 to +150	°C
Power Dissipation	P _D	1	W
Short Circuit Output Current	I _{os} Address	50	mA

* Permanent device damage may occur if "ABSOLUTE MAXIMUM RATINGS" are exceeded. Functional operation should be restricted to the conditions as detailed in the operational sections of this data sheet. Exposure to absolute maximum rating conditions for extended periods may affect device reliability.

RECOMMENDED OPERATING CONDITIONS (Voltage referenced to Vss, T_A= 0 to 70°C)

Parameter	Symbol	Min	Typ	Max	Units
Supply Voltage	V _{CC}	3.0	3.3	3.6	V
Ground	V _{SS}	0	0	0	V
Input High Voltage	V _{IH}	2.0	-	V _{CC} +0.3 ^{*1}	V
Input Low Voltage	V _{IL}	-0.3 ^{*2}	-	0.8	V

*1 : V_{CC}+1.3V at pulse width ≤15ns which is measured at V_{CC}

*2 : -1.3 at pulse width ≤15ns which is measured at V_{SS}

DC AND OPERATING CHARACTERISTICS (Recommended operating conditions unless otherwise noted.)

Parameter	Symbol	Min	Max	Units
Input Leakage Current (Any input 0≤V _{IN} ≤V _{CC} +0.3V, all other pins not under test=0 Volt)	I _{I(L)}	-5	5	uA
Output Leakage Current (Data out is disabled, 0V≤V _{OUT} ≤V _{CC})	I _{O(L)}	-5	5	uA
Output High Voltage Level(I _{OH} =-2mA)	V _{OH}	2.4	-	V
Output Low Voltage Level(I _{OL} =2mA)	V _{OL}	-	0.4	V

DC AND OPERATING CHARACTERISTICS (Continued)

Symbol	Power	Speed	Max		Units
			K4F661612C	K4F641612C	
I _{CC1}	Don't care	-45	90	130	mA
		-50	80	120	mA
		-60	70	110	mA
I _{CC2}	Normal L	Don't care	1	1	mA
			1	1	mA
I _{CC3}	Don't care	-45	90	130	mA
		-50	80	120	mA
		-60	70	110	mA
I _{CC4}	Don't care	-45	70	70	mA
		-50	60	60	mA
		-60	50	50	mA
I _{CC5}	Normal L	Don't care	0.5	0.5	mA
			200	200	uA
I _{CC6}	Don't care	-45	130	130	mA
		-50	120	120	mA
		-60	110	110	mA
I _{CC7}	L	Don't care	350	350	uA
I _{CCS}	L	Don't care	350	350	uA

I_{CC1}* : Operating Current (\overline{RAS} and \overline{UCAS} , \overline{LCAS} , Address cycling @trc=min.)

I_{CC2} : Standby Current ($\overline{RAS}=\overline{UCAS}=\overline{LCAS}=\overline{W}=V_{IH}$)

I_{CC3}* : \overline{RAS} -only Refresh Current ($\overline{UCAS}=\overline{LCAS}=V_{IH}$, \overline{RAS} , Address cycling @trc=min.)

I_{CC4}* : Fast Page Mode Current ($\overline{RAS}=V_{IL}$, \overline{UCAS} or \overline{LCAS} , Address cycling @tpc=min.)

I_{CC5} : Standby Current ($\overline{RAS}=\overline{UCAS}=\overline{LCAS}=\overline{W}=V_{CC}-0.2V$)

I_{CC6}* : \overline{CAS} -Before- \overline{RAS} Refresh Current (\overline{RAS} and \overline{UCAS} or \overline{LCAS} cycling @trc=min)

I_{CC7} : Battery back-up current, Average power supply current, Battery back-up mode

Input high voltage(V_{IH})= $V_{CC}-0.2V$, Input low voltage(V_{IL})= $0.2V$, \overline{UCAS} , $\overline{LCAS}=\overline{CAS}$ -before- \overline{RAS} cycling or $0.2V$,
 \overline{W} , $\overline{OE}=V_{IH}$, Address=Don't care, DQ=Open, TRC=31.25us

I_{CCS} : Self Refresh Current

$\overline{RAS}=\overline{UCAS}=\overline{LCAS}=0.2V$, $\overline{W}=\overline{OE}=A_0 \sim A_{12}(A_{11})=V_{CC}-0.2V$ or $0.2V$, DQ0 ~ DQ15= $V_{CC}-0.2V$, $0.2V$ or Open

***Note :** I_{CC1}, I_{CC3}, I_{CC4} and I_{CC6} are dependent on output loading and cycle rates. Specified values are obtained with the output open. I_{CC} is specified as an average current. In I_{CC1}, I_{CC3} and I_{CC6}, address can be changed maximum once while $\overline{RAS}=V_{IL}$. In I_{CC4}, address can be changed maximum once within one fast page mode cycle time, tpc.



K4F661612C, K4F641612C

CMOS DRAM

CAPACITANCE (TA=25°C, VCC=3.3V, f=1MHz)

Parameter	Symbol	Min	Max	Units
Input capacitance [A0 ~ A12]	CIN1	-	5	pF
Input capacitance [$\overline{\text{RAS}}$, $\overline{\text{UCAS}}$, $\overline{\text{LCAS}}$, $\overline{\text{W}}$, $\overline{\text{OE}}$]	CIN2	-	7	pF
Output capacitance [DQ0 - DQ15]	CDQ	-	7	pF

AC CHARACTERISTICS (0°C ≤ TA ≤ 70°C, See note 2)

Test condition : VCC=3.3V±0.3V, Vih/Vil=2.2/0.7V, Voh/Vol=2.0/0.8V

Parameter	Symbol	-45		-50		-60		Units	Note
		Min	Max	Min	Max	Min	Max		
Random read or write cycle time	tRC	80		90		110		ns	
Read-modify-write cycle time	tRWC	115		133		153		ns	
Access time from $\overline{\text{RAS}}$	tRAC		45		50		60	ns	3,4,10
Access time from $\overline{\text{CAS}}$	tCAC		12		13		15	ns	3,4,5
Access time from column address	tAA		23		25		30	ns	3,10
$\overline{\text{CAS}}$ to output in Low-Z	tCLZ	0		0		0		ns	3
Output buffer turn-off delay	tOFF	0	13	0	13	0	13	ns	6
Transition time (rise and fall)	tT	1	50	1	50	1	50	ns	2
$\overline{\text{RAS}}$ precharge time	tRP	25		30		40		ns	
$\overline{\text{RAS}}$ pulse width	tRAS	45	10K	50	10K	60	10K	ns	
$\overline{\text{RAS}}$ hold time	tRSH	12		13		15		ns	
$\overline{\text{CAS}}$ hold time	tCSH	45		50		60		ns	
$\overline{\text{CAS}}$ pulse width	tCAS	12	10K	13	10K	15	10K	ns	
$\overline{\text{RAS}}$ to $\overline{\text{CAS}}$ delay time	tRCD	18	33	20	37	20	45	ns	4
$\overline{\text{RAS}}$ to column address delay time	tRAD	13	22	15	25	15	30	ns	10
$\overline{\text{CAS}}$ to $\overline{\text{RAS}}$ precharge time	tCRP	5		5		5		ns	
Row address set-up time	tASR	0		0		0		ns	
Row address hold time	tRAH	8		10		10		ns	
Column address set-up time	tASC	0		0		0		ns	13
Column address hold time	tCAH	8		10		10		ns	13
Column address to $\overline{\text{RAS}}$ lead time	tRAL	23		25		30		ns	
Read command set-up time	tRCS	0		0		0		ns	
Read command hold time referenced to $\overline{\text{CAS}}$	tRCH	0		0		0		ns	8
Read command hold time referenced to $\overline{\text{RAS}}$	tRRH	0		0		0		ns	8
Write command hold time	tWCH	8		10		10		ns	
Write command pulse width	tWP	8		10		10		ns	
Write command to $\overline{\text{RAS}}$ lead time	tRWL	13		15		15		ns	
Write command to $\overline{\text{CAS}}$ lead time	tCWL	12		13		15		ns	16
Data set-up time	tDS	0		0		0		ns	9,19
Data hold time	tDH	10		10		10		ns	9,19



AC CHARACTERISTICS (Continued)

Parameter	Symbol	-45		-50		-60		Units	Note
		Min	Max	Min	Max	Min	Max		
Refresh period (Normal)	tREF		64		64		64	ms	
Refresh period (L-ver)	tREF		128		128		128	ms	
Write command set-up time	tWCS	0		0		0		ns	7
$\overline{\text{CAS}}$ to $\overline{\text{W}}$ delay time	tCWD	32		36		38		ns	7,15
$\overline{\text{RAS}}$ to $\overline{\text{W}}$ delay time	tRWD	67		73		83		ns	7
Column address to $\overline{\text{W}}$ delay time	tAWD	43		48		53		ns	7
$\overline{\text{CAS}}$ precharge $\overline{\text{W}}$ delay time	tCPWD	48		53		60		ns	
$\overline{\text{CAS}}$ set-up time ($\overline{\text{CAS}}$ -before- $\overline{\text{RAS}}$ refresh)	tCSR	5		5		5		ns	17
$\overline{\text{CAS}}$ hold time ($\overline{\text{CAS}}$ -before- $\overline{\text{RAS}}$ refresh)	tCHR	10		10		10		ns	18
$\overline{\text{RAS}}$ to $\overline{\text{CAS}}$ precharge time	tRPC	5		5		5		ns	
Access time from $\overline{\text{CAS}}$ precharge	tCPA		26		30		35	ns	3
Fast Page mode cycle time	tPC	31		35		40		ns	
Fast Page mode read-modify-write cycle time	tPRWC	70		76		85		ns	
$\overline{\text{CAS}}$ precharge time (Fast page cycle)	tCP	9		10		10		ns	14
$\overline{\text{RAS}}$ pulse width (Fast page cycle)	tRASP	45	200K	50	200	60	200	ns	
$\overline{\text{RAS}}$ hold time from $\overline{\text{CAS}}$ precharge	tRHCP	28		30		35		ns	
$\overline{\text{OE}}$ access time	tOEA		12		13		15	ns	3
$\overline{\text{OE}}$ to data delay	tOED	12		13		13		ns	
Output buffer turn off delay time from $\overline{\text{OE}}$	tOEZ	0	13	0	13	0	13	ns	6
$\overline{\text{OE}}$ command hold time	tOEH	12		13		15		ns	
Write command set-up time (Test mode in)	tWTS	10		10		10		ns	11
Write command hold time (Test mode in)	tWTH	15		15		15		ns	11
$\overline{\text{W}}$ to $\overline{\text{RAS}}$ precharge time (C-B-R refresh)	tWRP	10		10		10		ns	
$\overline{\text{W}}$ to $\overline{\text{RAS}}$ hold time (C-B-R refresh)	tWRH	10		10		10		ns	
$\overline{\text{RAS}}$ pulse width (C-B-R self refresh)	tRASS	100		100		100		us	20,21,22
$\overline{\text{RAS}}$ precharge time (C-B-R self refresh)	tRPS	80		90		110		ns	20,21,22
$\overline{\text{CAS}}$ hold time (C-B-R self refresh)	tCHS	-50		-50		-50		ns	20,21,22

TEST MODE CYCLE

(Note 11)

Parameter	Symbol	-45		-50		-60		Units	Note
		Min	Max	Min	Max	Min	Max		
Random read or write cycle time	t _{RC}	85		95		115		ns	
Read-modify-write cycle time	t _{RWC}	120		138		160		ns	
Access time from $\overline{\text{RAS}}$	t _{RAC}		50		55		65	ns	3,4,10,12
Access time from $\overline{\text{CAS}}$	t _{CAC}		17		18		20	ns	3,4,5,12
Access time from column address	t _{AA}		28		30		35	ns	3,10,12
$\overline{\text{RAS}}$ pulse width	t _{RAS}	50	10K	55	10K	65	10K	ns	
$\overline{\text{CAS}}$ pulse width	t _{CAS}	17	10K	18	10K	20	10K	ns	
$\overline{\text{RAS}}$ hold time	t _{RSH}	17		18		20		ns	
$\overline{\text{CAS}}$ hold time	t _{CSH}	50		55		65		ns	
Column Address to $\overline{\text{RAS}}$ lead time	t _{RAL}	28		30		35		ns	
$\overline{\text{CAS}}$ to $\overline{\text{W}}$ delay time	t _{CWD}	37		41		43		ns	7
$\overline{\text{RAS}}$ to $\overline{\text{W}}$ delay time	t _{RWD}	72		78		88		ns	7
Column Address to $\overline{\text{W}}$ delay time	t _{AWD}	48		53		58		ns	7
Fast Page mode cycle time	t _{PC}	36		40		45		ns	
Fast Page mode read-modify-write cycle time	t _{PRWC}	75		81		90		ns	
$\overline{\text{RAS}}$ pulse width (Fast page cycle)	t _{RASP}	50	200K	55	200K	65	200K	ns	
Access time from $\overline{\text{CAS}}$ precharge	t _{CPA}		31		35		40	ns	3
$\overline{\text{OE}}$ access time	t _{OEA}		17		18		20	ns	
$\overline{\text{OE}}$ to data delay	t _{OED}	17		18		18		ns	
$\overline{\text{OE}}$ command hold time	t _{OEH}	17		18		20		ns	



ELECTRONICS

NOTES

1. An initial pause of 200 μ s is required after power-up followed by any 8 ROR or CBR cycles before proper device operation is achieved.
2. $V_{IH}(\min)$ and $V_{IL}(\max)$ are reference levels for measuring timing of input signals. Transition times are measured between $V_{IH}(\min)$ and $V_{IL}(\max)$ and are assumed to be 5ns for all inputs.
3. Measured with a load equivalent to 1 TTL load and 100pF.
4. Operation within the $t_{RCD}(\max)$ limit insures that $t_{RAC}(\max)$ can be met. $t_{RCD}(\max)$ is specified as a reference point only. If t_{RCD} is greater than the specified $t_{RCD}(\max)$ limit, then access time is controlled exclusively by t_{CAC} .
5. Assumes that $t_{RCD} \geq t_{RCD}(\max)$.
6. $t_{OFF}(\min)$ and $t_{OEZ}(\max)$ define the time at which the output achieves the open circuit condition and are not referenced V_{oh} or V_{ol} .
7. t_{WCS} , t_{RWD} , t_{CWD} and t_{AWD} are non restrictive operating parameters. They are included in the data sheet as electric characteristics only. If $t_{WCS} \geq t_{WCS}(\min)$, the cycles is an early write cycle and the data output will remain high impedance for the duration of the cycle. If $t_{CWD} \geq t_{CWD}(\min)$, $t_{RWD} \geq t_{RWD}(\min)$ and $t_{AWD} \geq t_{AWD}(\min)$, then the cycle is a read-modify-write cycle and the data output will contain the data read from the selected address. If neither of the above conditions is satisfied, the condition of the data out is indeterminate.
8. Either t_{RCH} or t_{RRH} must be satisfied for a read cycle.
9. These parameters are referenced to the \overline{CAS} leading edge in early write cycles and to the \overline{W} falling edge in read-modify-write cycles.
10. Operation within the $t_{RAD}(\max)$ limit insures that $t_{RAC}(\max)$ can be met. $t_{RAD}(\max)$ is specified as a reference point only. If t_{RAD} is greater than the specified $t_{RAD}(\max)$ limit, then access time is controlled by t_{AA} .
11. These specifications are applied in the test mode.
12. In test mode read cycle, the value of t_{RAC} , t_{AA} , t_{CAC} is delayed by 2ns to 5ns for the specified values. These parameters should be specified in test mode cycles by adding the above value to the specified value in this data sheet.

K4F64(6)1612C Truth Table

RAS	LCAS	UCAS	W	OE	DQ0 - DQ7	DQ8-DQ15	STATE
H	X	X	X	X	Hi-Z	Hi-Z	Standby
L	H	H	X	X	Hi-Z	Hi-Z	Refresh
L	L	H	H	L	DQ-OUT	Hi-Z	Byte Read
L	H	L	H	L	Hi-Z	DQ-OUT	Byte Read
L	L	L	H	L	DQ-OUT	DQ-OUT	Word Read
L	L	H	L	H	DQ-IN	-	Byte Write
L	H	L	L	H	-	DQ-IN	Byte Write
L	L	L	L	H	DQ-IN	DQ-IN	Word Write
L	L	L	H	H	Hi-Z	Hi-Z	-



- 13. tASC, tCAH are referenced to the earlier $\overline{\text{CAS}}$ falling edge.
- 14. tCP is specified from the last $\overline{\text{CAS}}$ rising edge in the previous cycle to the first $\overline{\text{CAS}}$ falling edge in the next cycle.
- 15. tCWD is referenced to the later $\overline{\text{CAS}}$ falling edge at word read-modify-write cycle.
- 16. tCWL is specified from $\overline{\text{W}}$ falling edge to the earlier $\overline{\text{CAS}}$ rising edge.
- 17. tCSR is referenced to earlier $\overline{\text{CAS}}$ falling before $\overline{\text{RAS}}$ transition low.
- 18. tCHR is referenced to the later $\overline{\text{CAS}}$ rising high after $\overline{\text{RAS}}$ transition low.

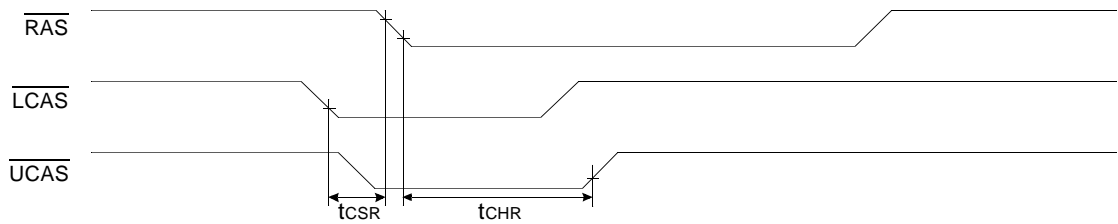

- 19. tDS is specified for the earlier $\overline{\text{CAS}}$ falling edge and tDH is specified by the later $\overline{\text{CAS}}$ falling edge.

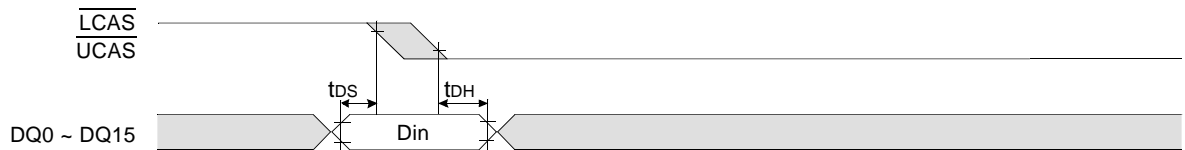

- 20. If $t_{\text{RASS}} \geq 100\mu\text{s}$, then $\overline{\text{RAS}}$ precharge time must use t_{RPS} instead of t_{RP} .
- 21. For $\overline{\text{RAS}}$ -only-Refresh and Burst $\overline{\text{CAS}}$ -before- $\overline{\text{RAS}}$ refresh mode, 4096 cycles(4K/8K) of burst refresh must be executed within 64ms before and after self refresh, in order to meet refresh specification.
- 22. For distributed $\overline{\text{CAS}}$ -before- $\overline{\text{RAS}}$ with 15.6us interval, CBR refresh should be executed with in 15.6us immediately before and after self refresh in order to meet refresh specification.

WORD READ CYCLE

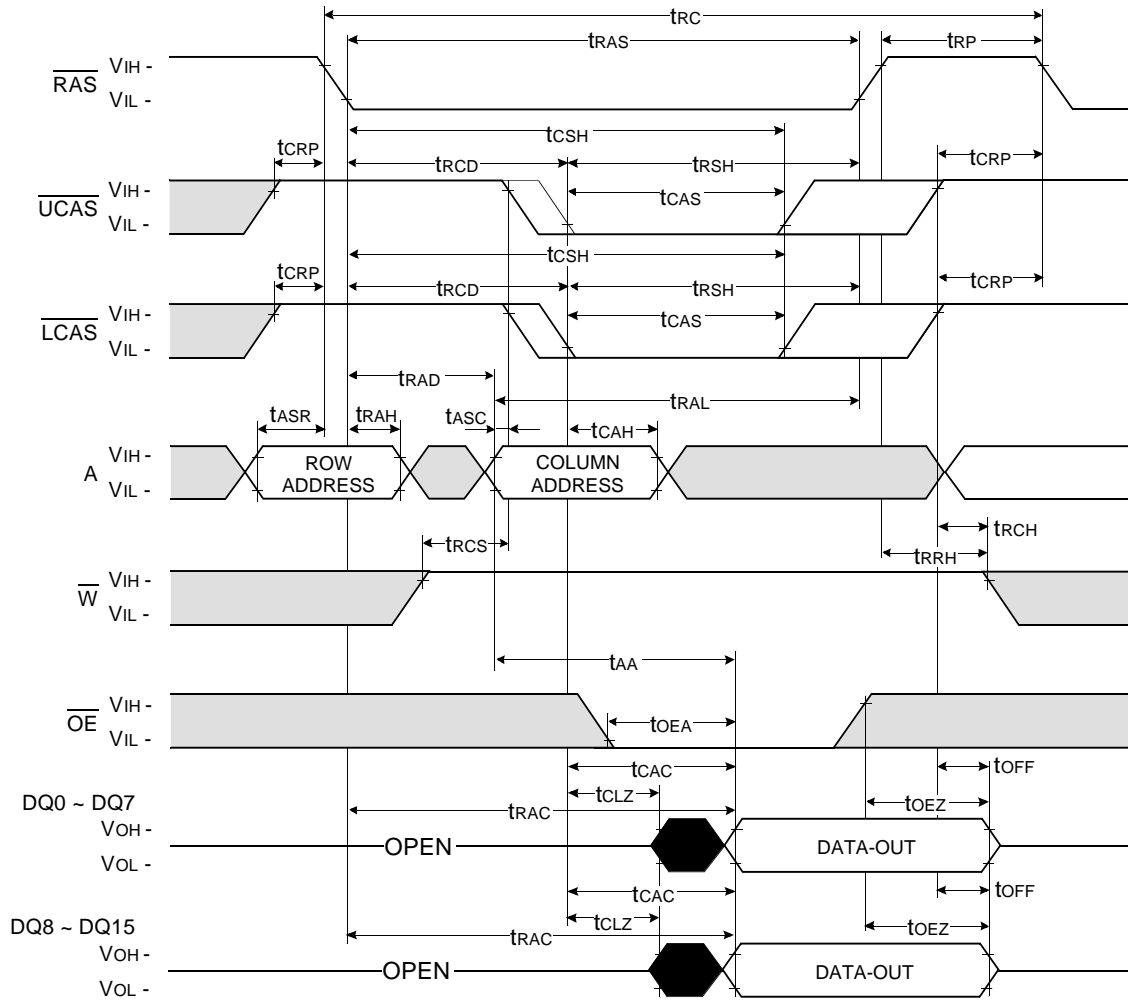

Don't care
 Undefined

LOWER BYTE READ CYCLE

NOTE : DIN = OPEN

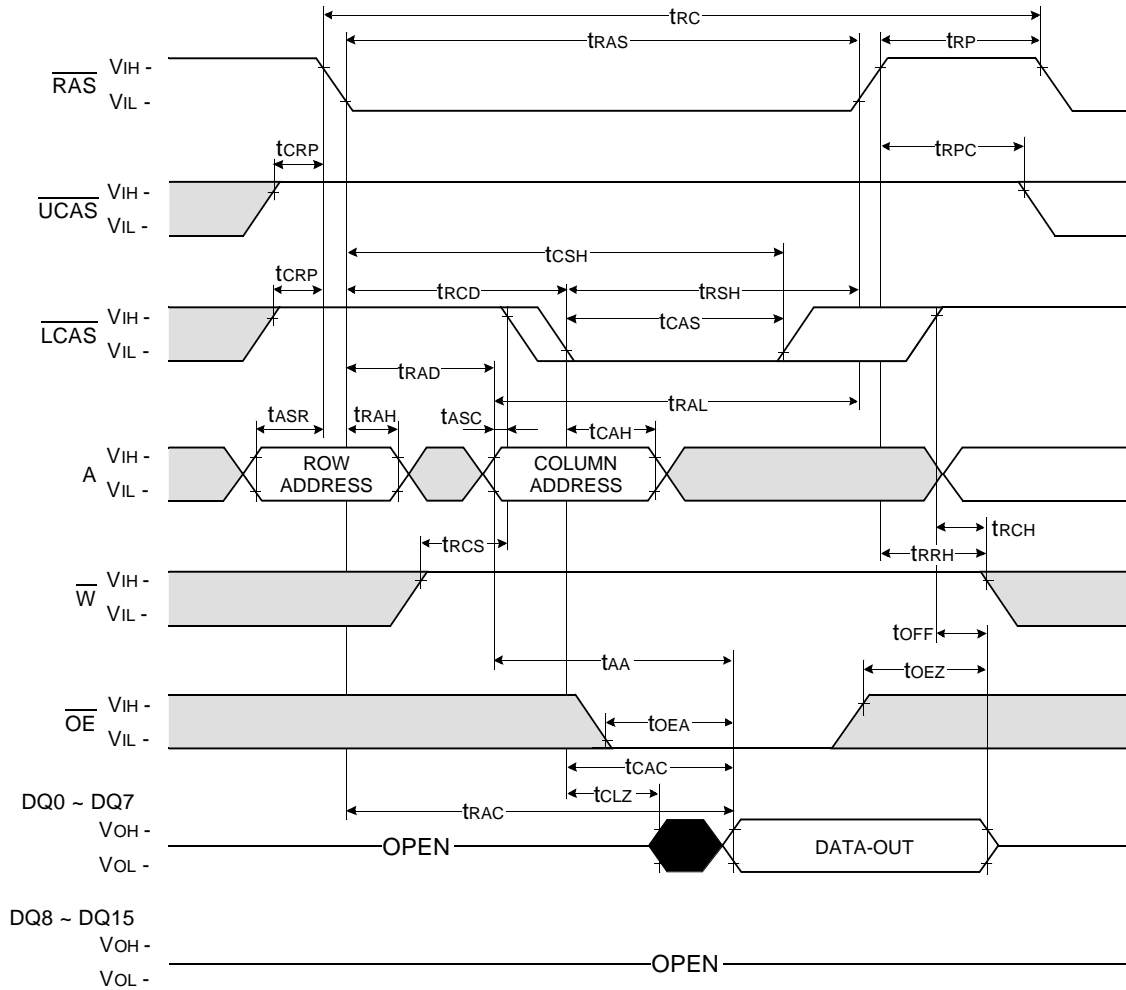

Don't care
 Undefined

UPPER BYTE READ CYCLE

NOTE : DIN = OPEN

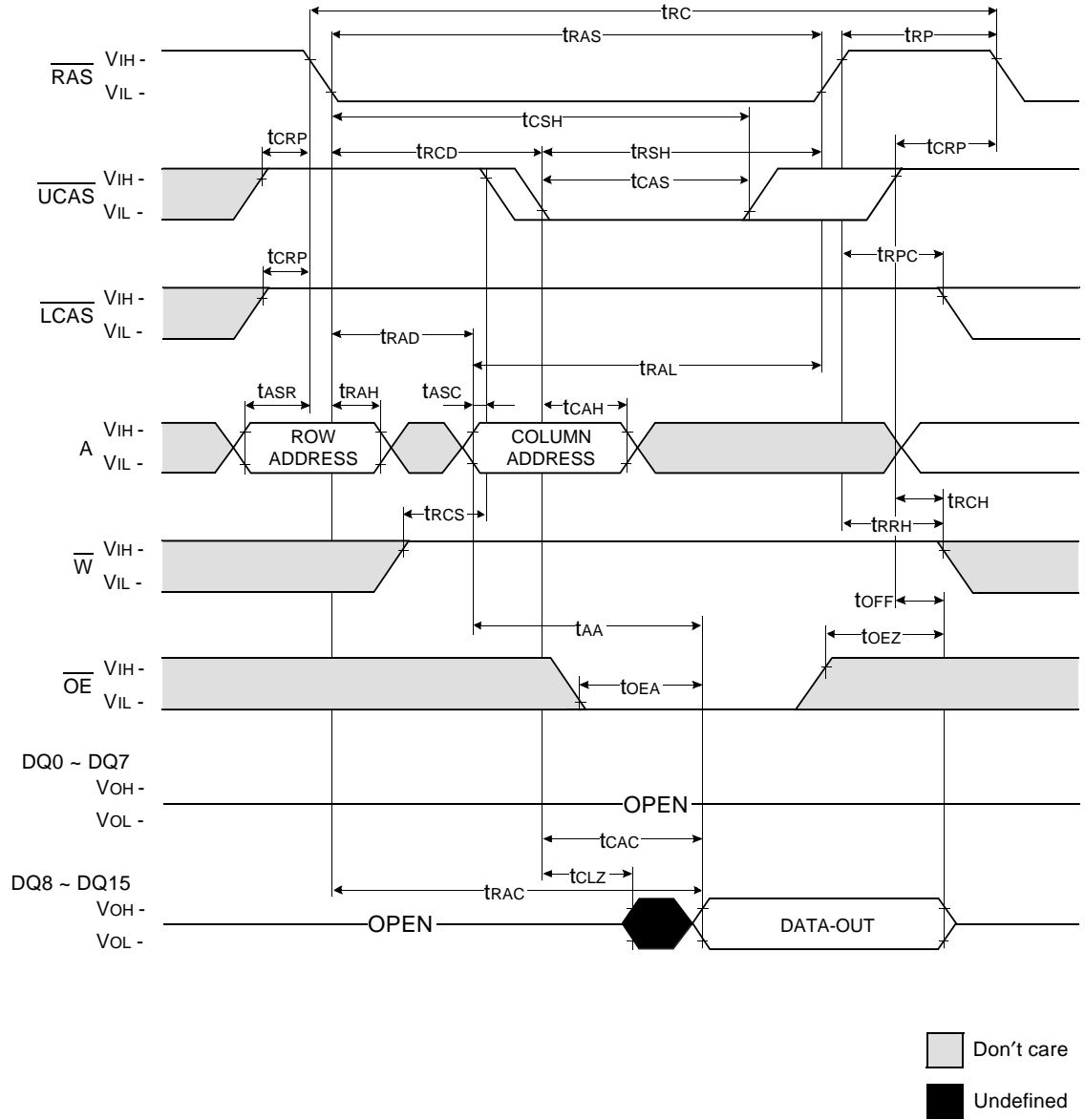

WORD WRITE CYCLE (EARLY WRITE)

NOTE : DOUT = OPEN

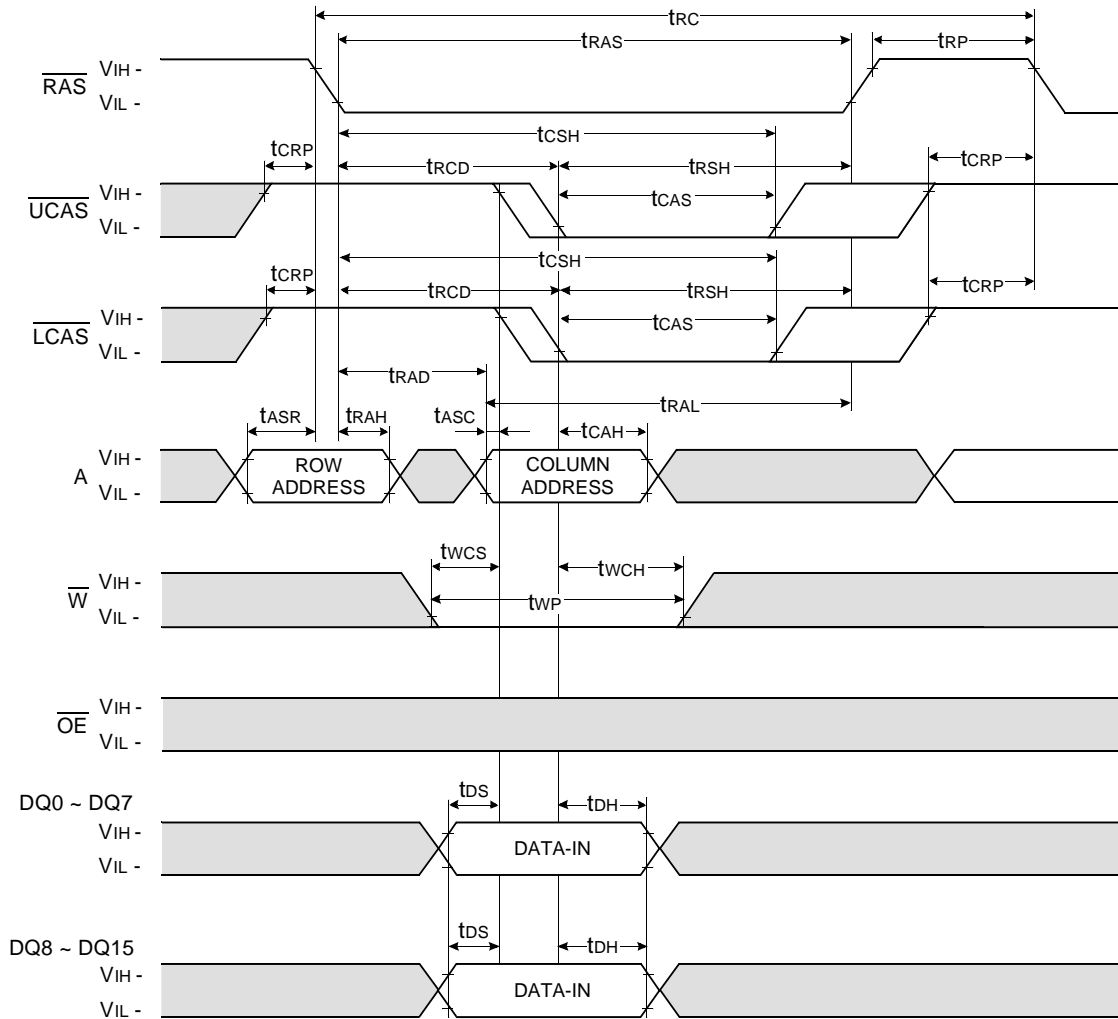

Don't care
 Undefined

LOWER BYTE WRITE CYCLE (EARLY WRITE)

NOTE : DOUT = OPEN

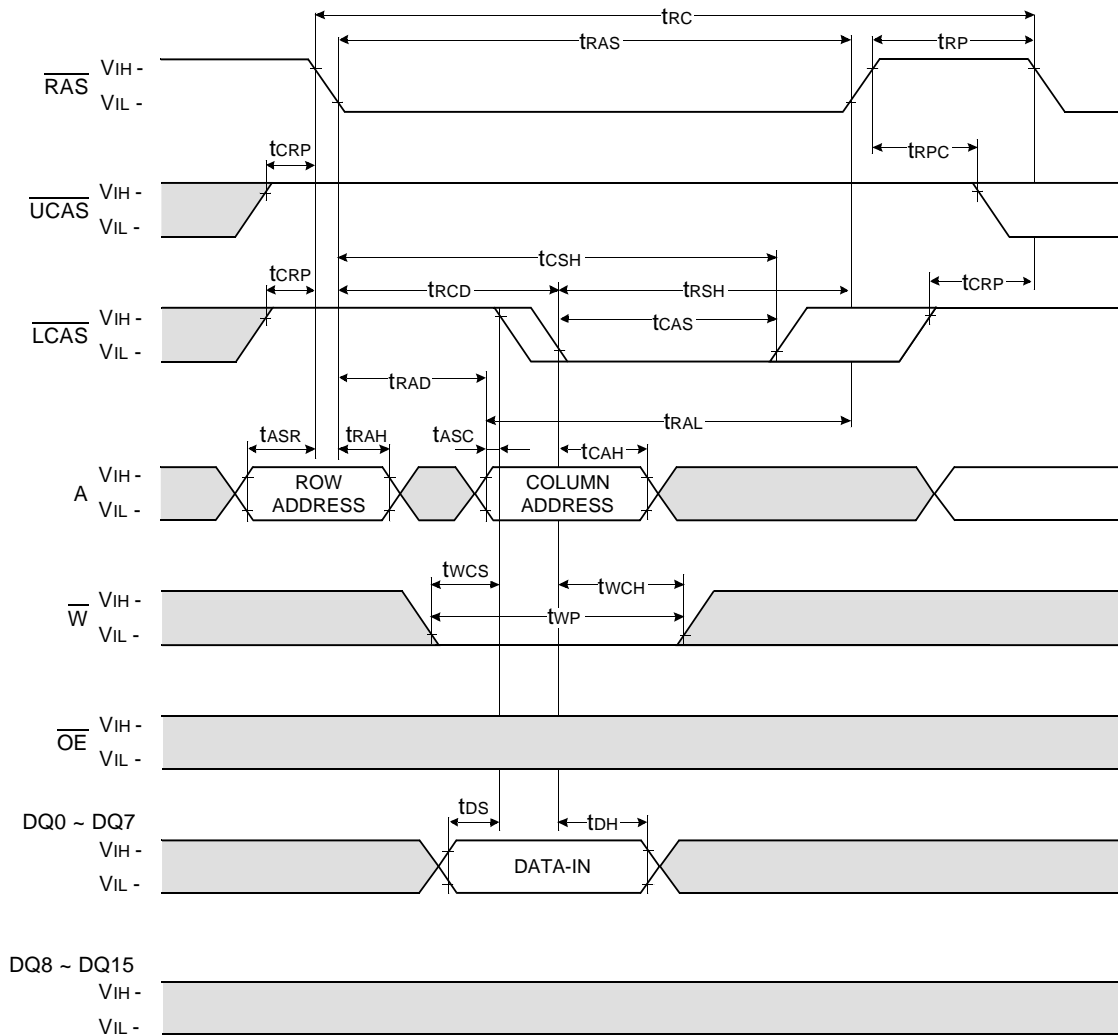

Don't care
 Undefined

UPPER BYTE WRITE CYCLE (EARLY WRITE)

NOTE : DOUT = OPEN

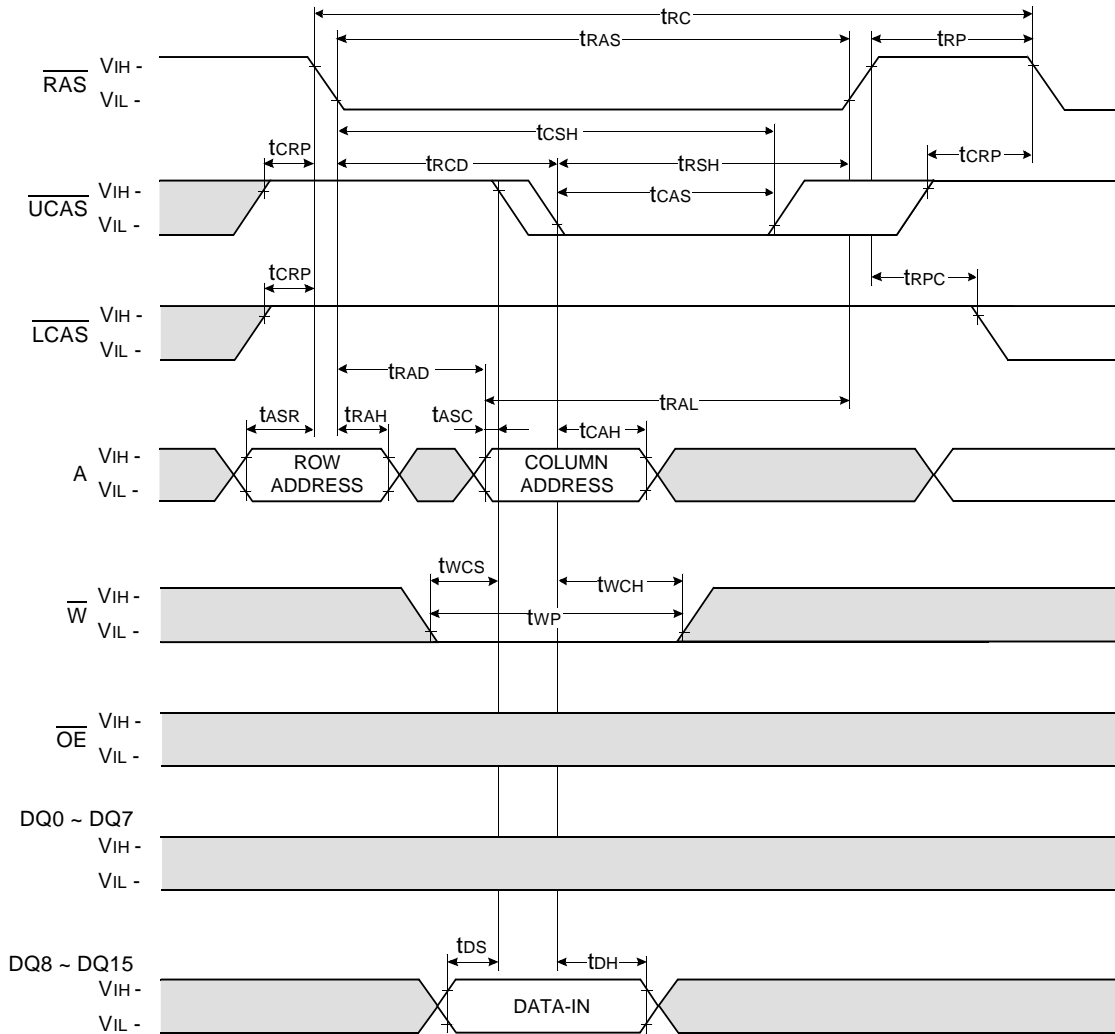

Don't care
 Undefined

WORD WRITE CYCLE (\overline{OE} CONTROLLED WRITE)

NOTE : DOUT = OPEN

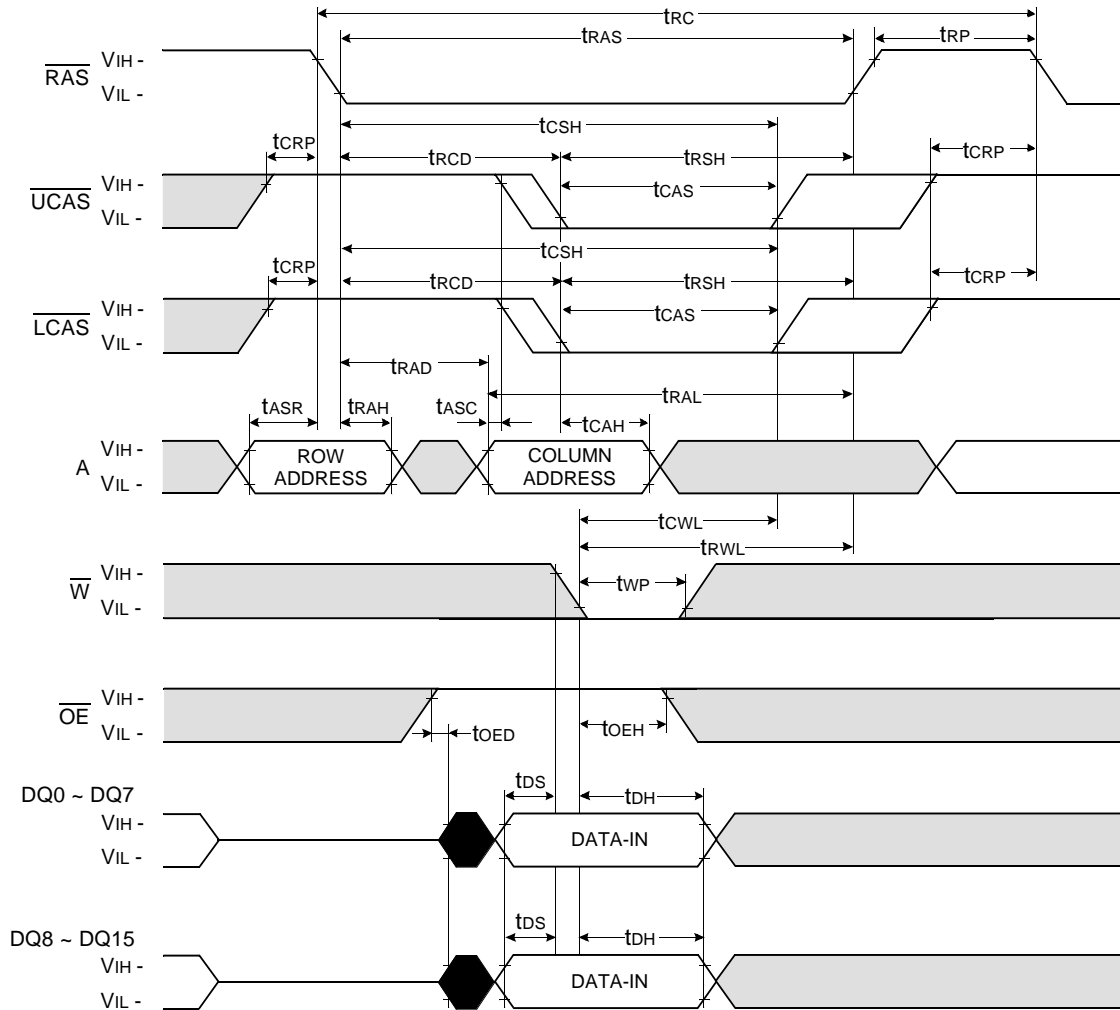

Don't care
 Undefined

LOWER BYTE WRITE CYCLE (\overline{OE} CONTROLLED WRITE)

NOTE : DOUT = OPEN

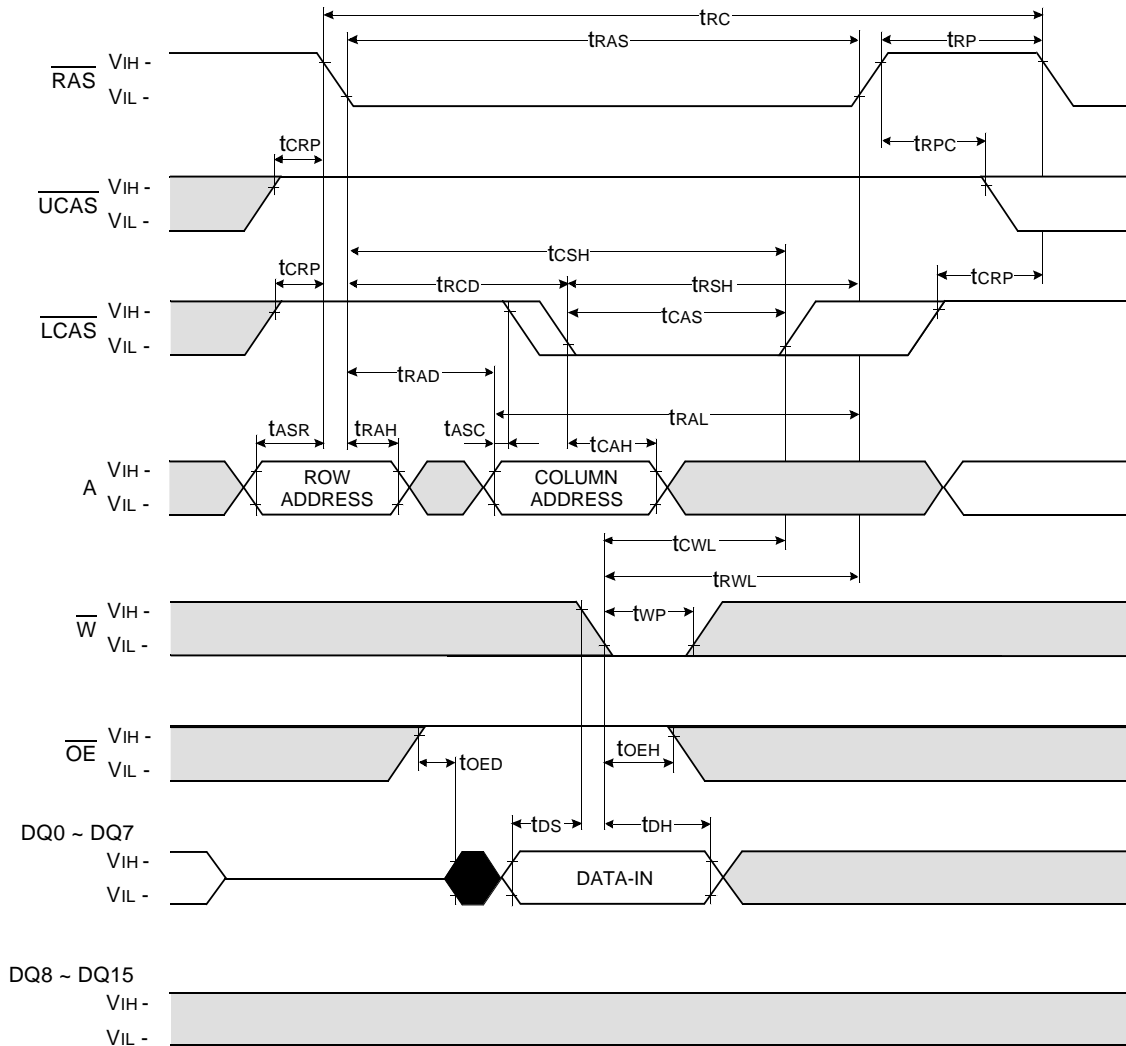

Don't care
 Undefined

UPPER BYTE WRITE CYCLE (\overline{OE} CONTROLLED WRITE)

NOTE : DOUT = OPEN

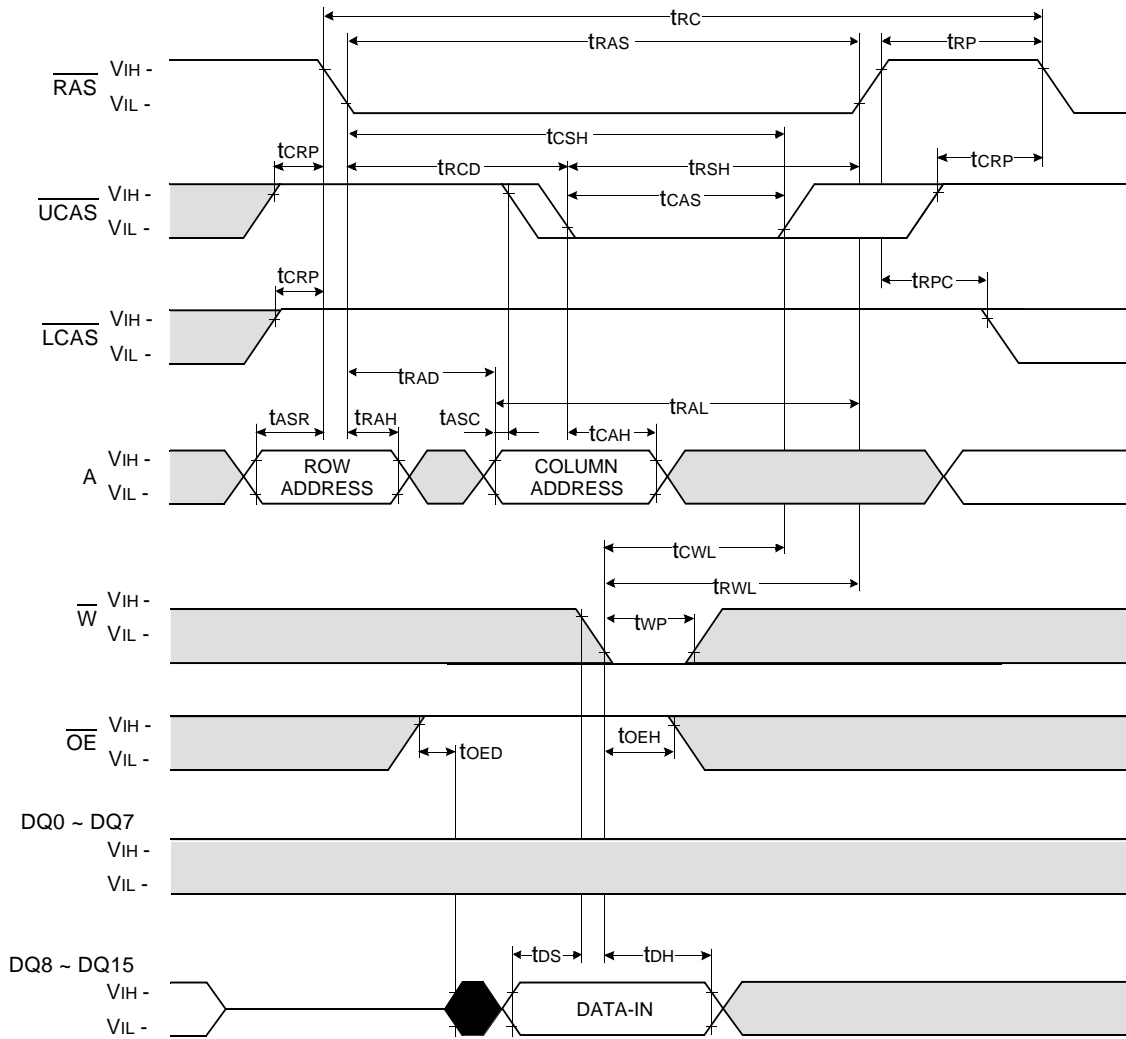

Don't care
 Undefined

WORD READ - MODIFY - WRITE CYCLE

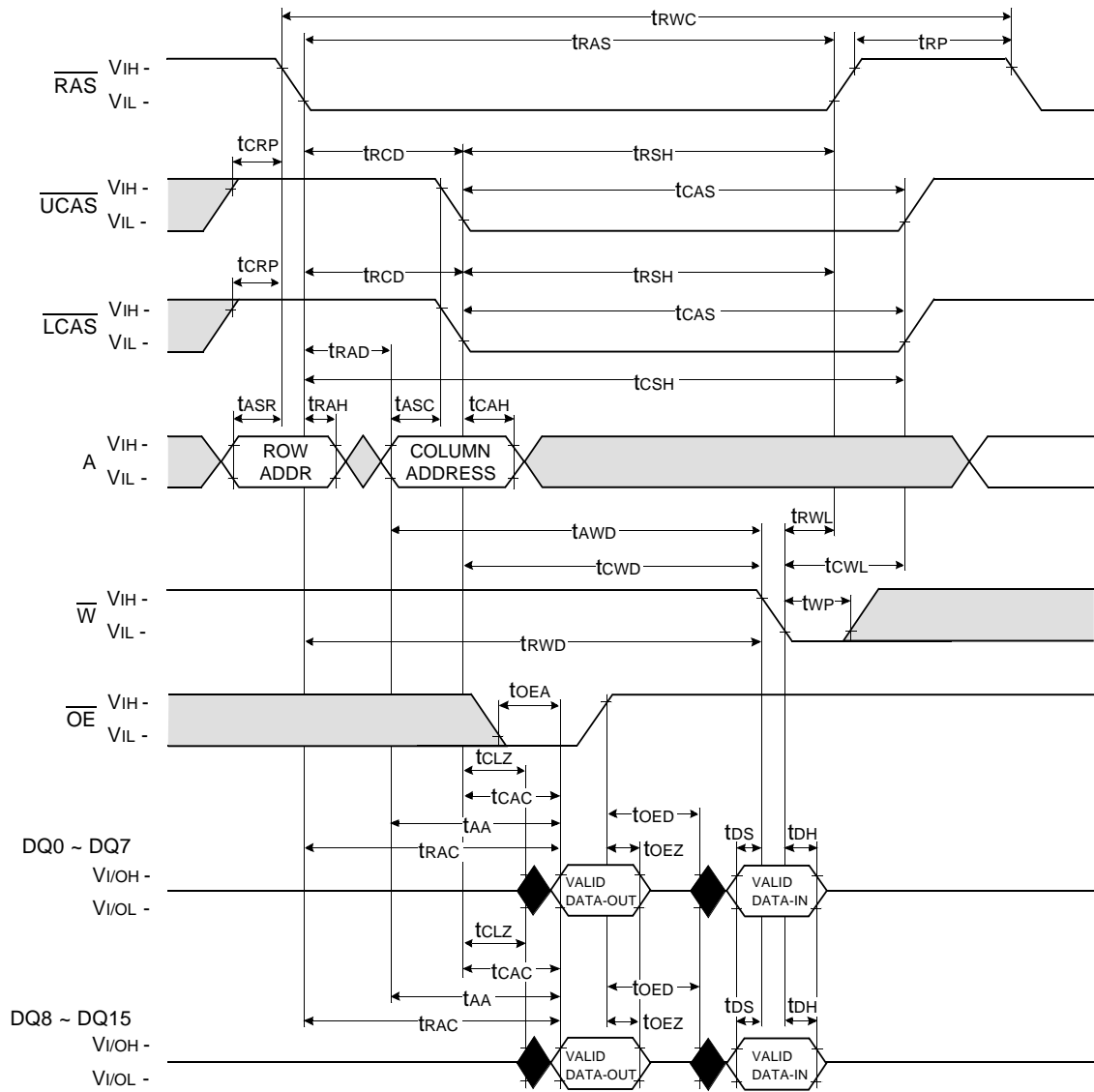

Don't care
 Undefined

LOWER-BYTE READ - MODIFY - WRITE CYCLE

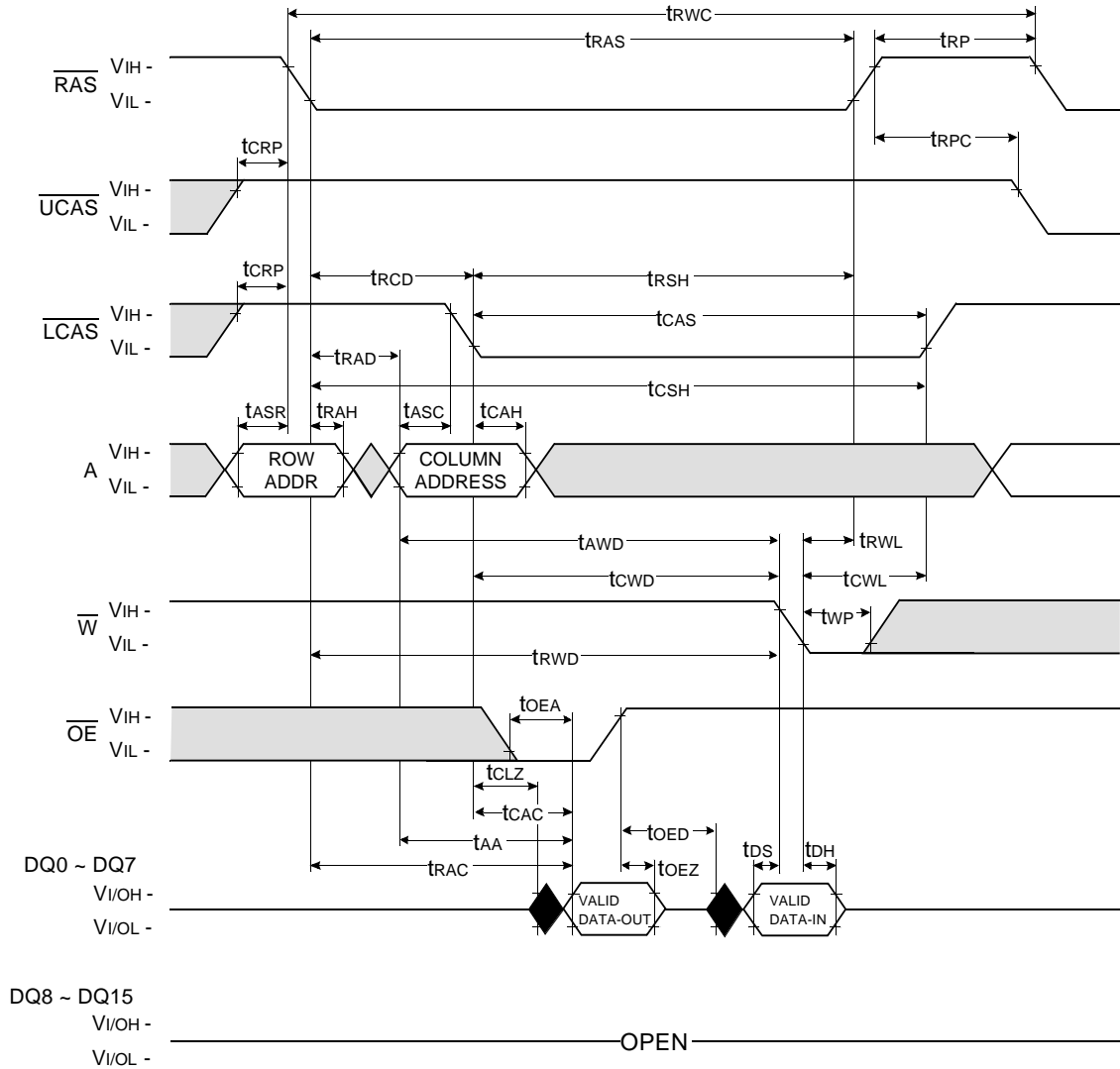

UPPER-BYTE READ - MODIFY - WRITE CYCLE

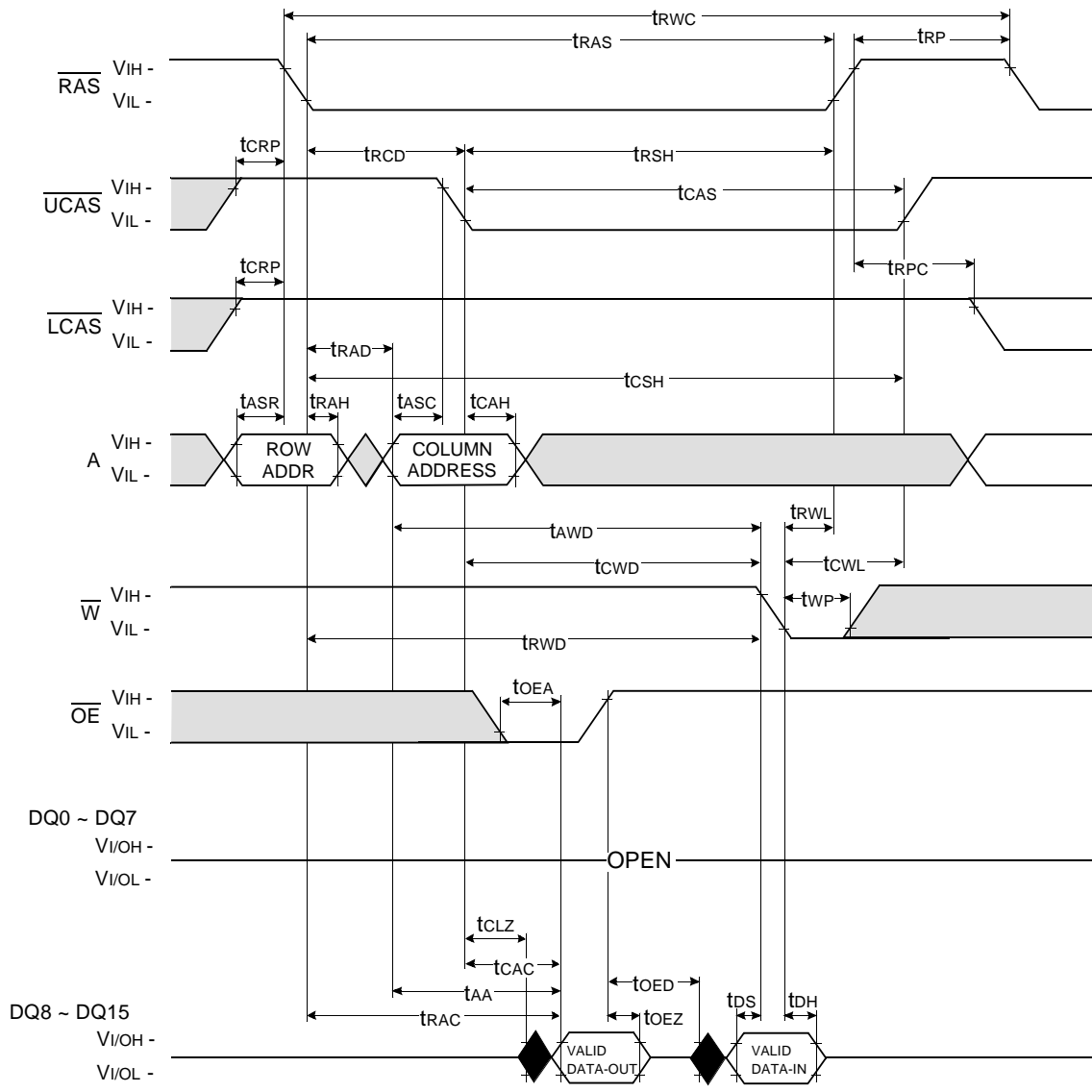

Don't care
 Undefined



FAST PAGE MODE WORD READ CYCLE

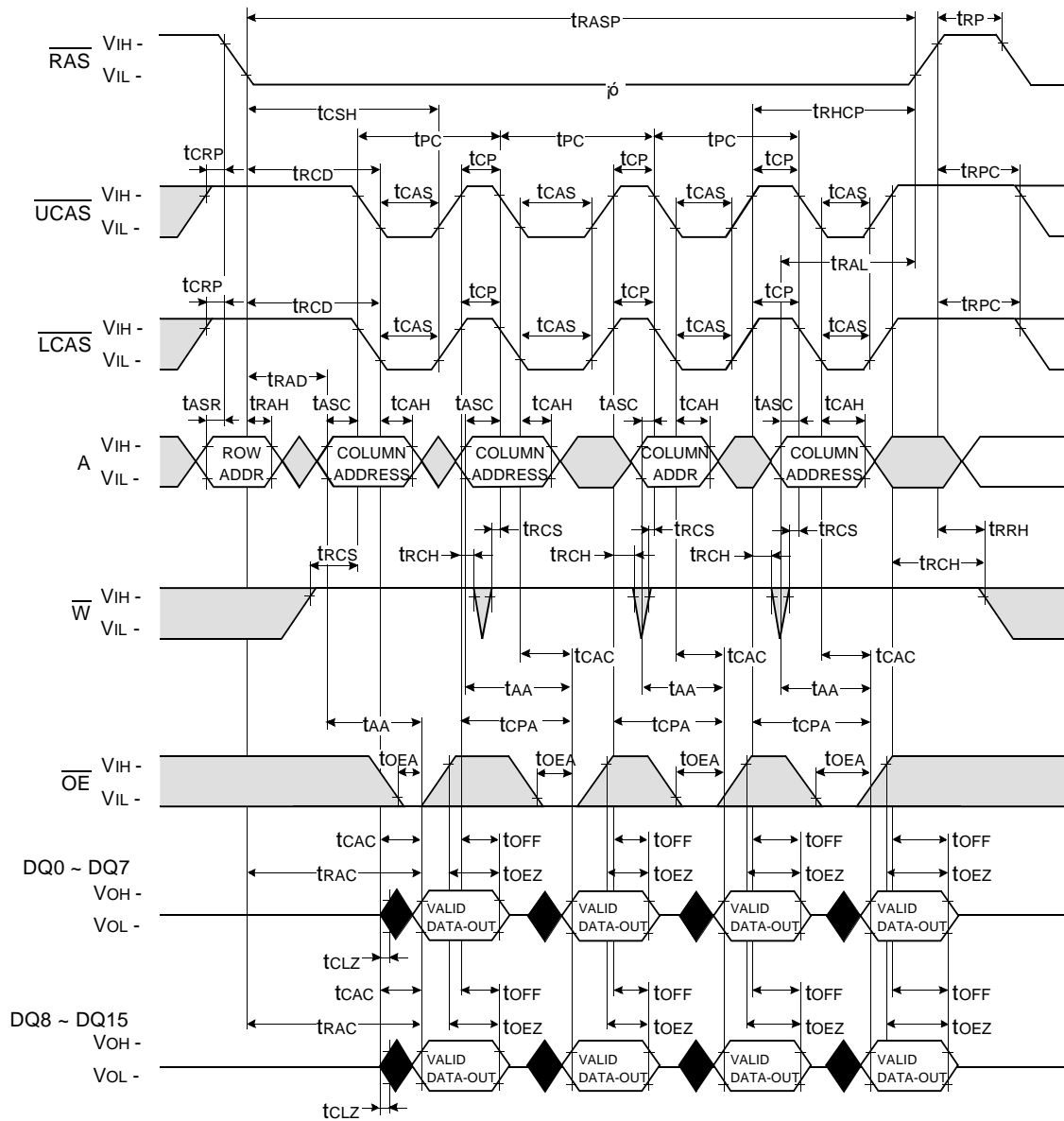

Don't care
 Undefined

FAST PAGE MODE LOWER BYTE READ CYCLE

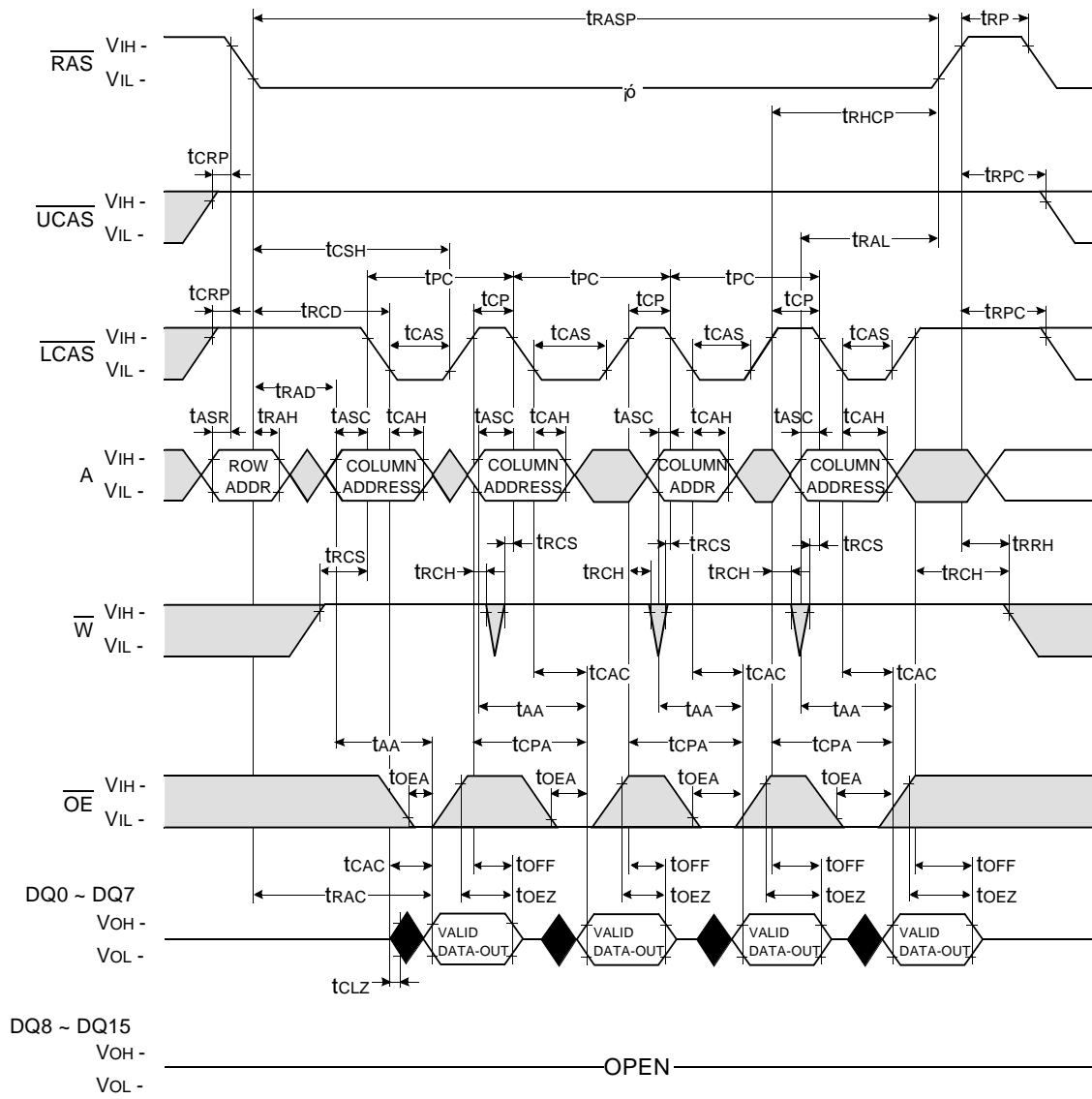

Don't care
 Undefined

FAST PAGE MODE UPPER BYTE READ CYCLE

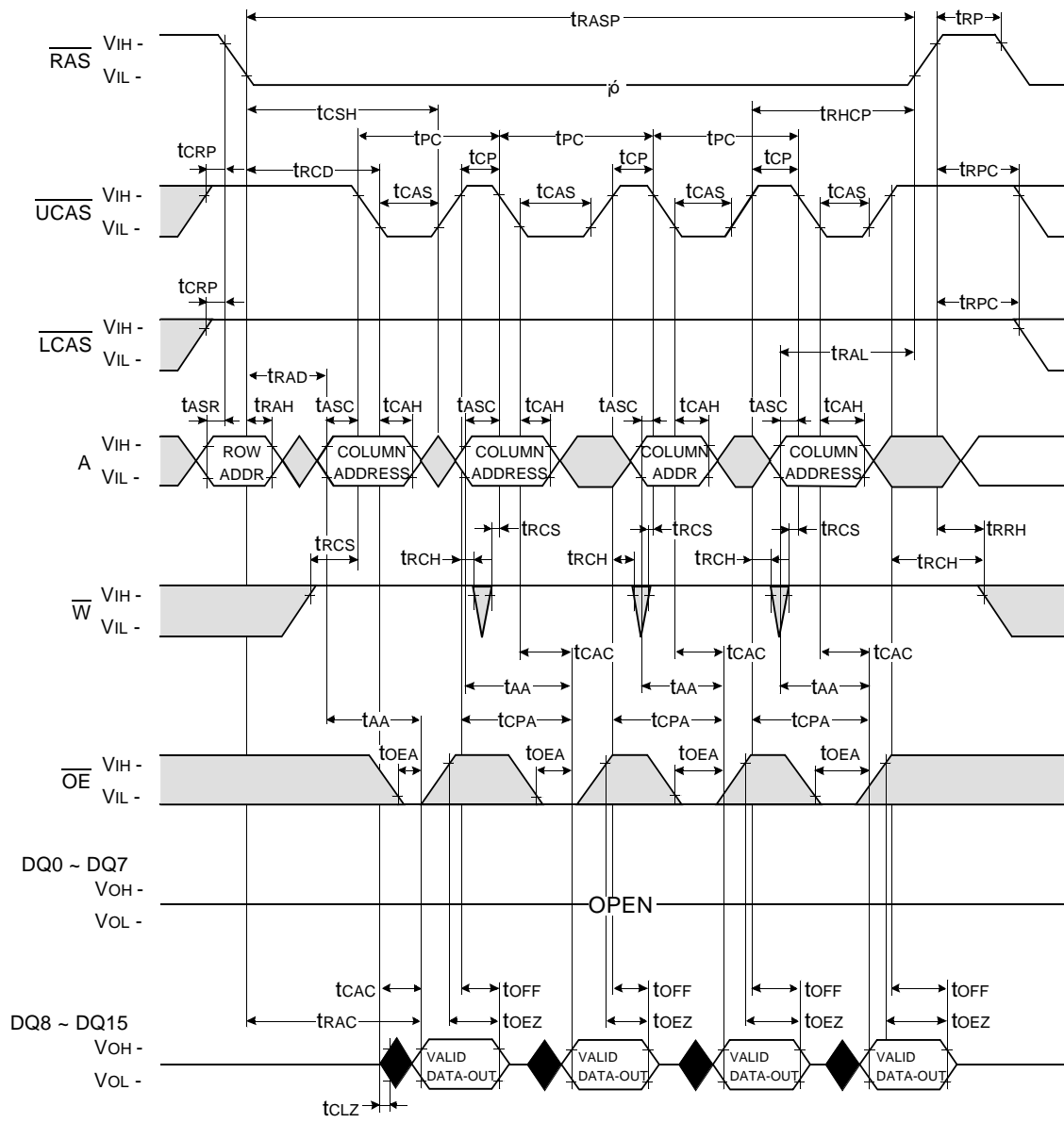

Don't care
 Undefined



FAST PAGE MODE WORD WRITE CYCLE (EARLY WRITE)

NOTE : DOUT = OPEN

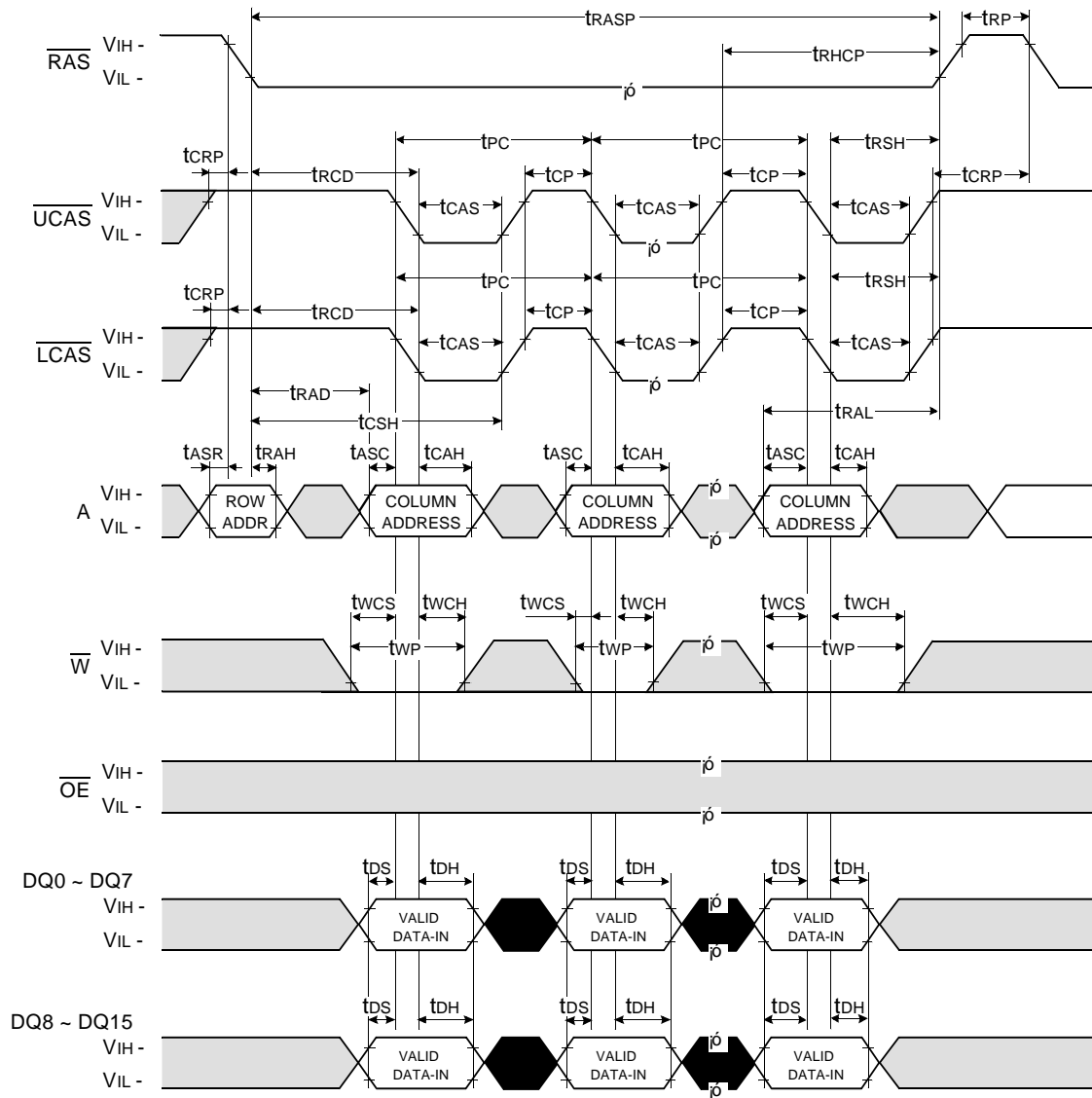

Don't care
 Undefined

FAST PAGE MODE LOWER BYTE WRITE CYCLE (EARLY WRITE)

NOTE : DOUT = OPEN

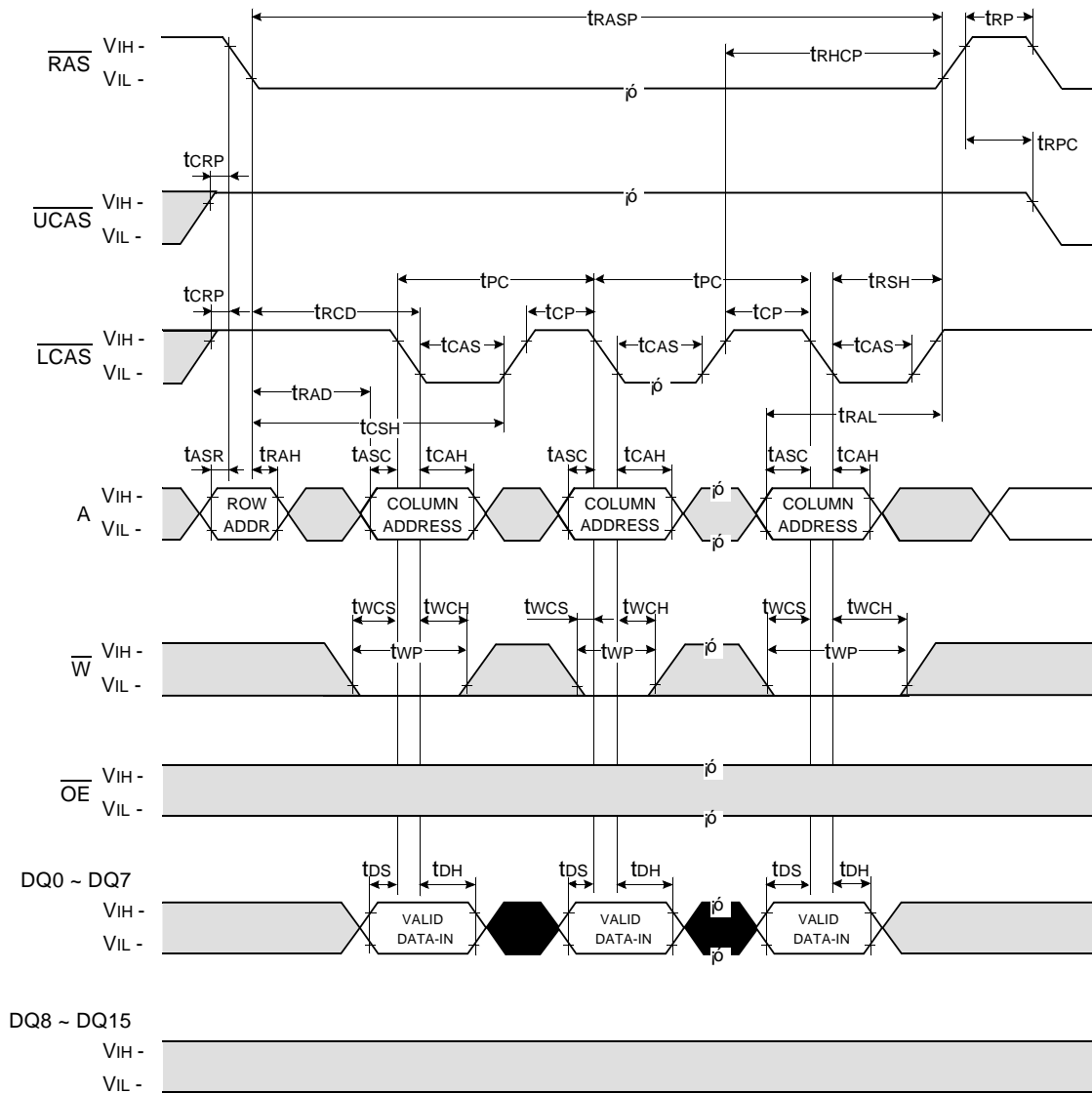

□ Don't care
 ■ Undefined

FAST PAGE MODE UPPER BYTE WRITE CYCLE (EARLY WRITE)

NOTE : DOUT = OPEN

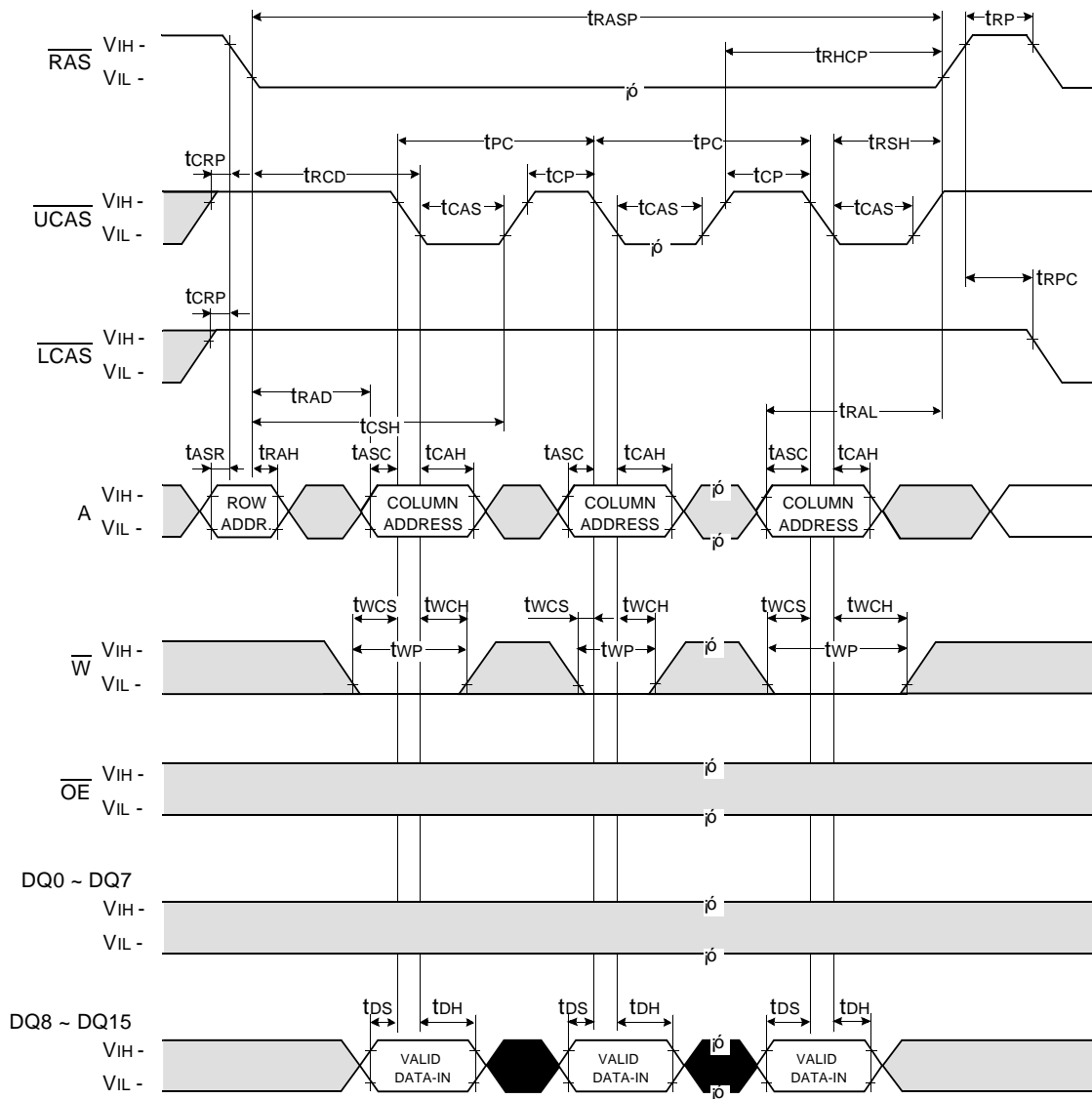

Don't care
 Undefined

FAST PAGE MODE WORD READ-MODIFY-WRITE CYCLE

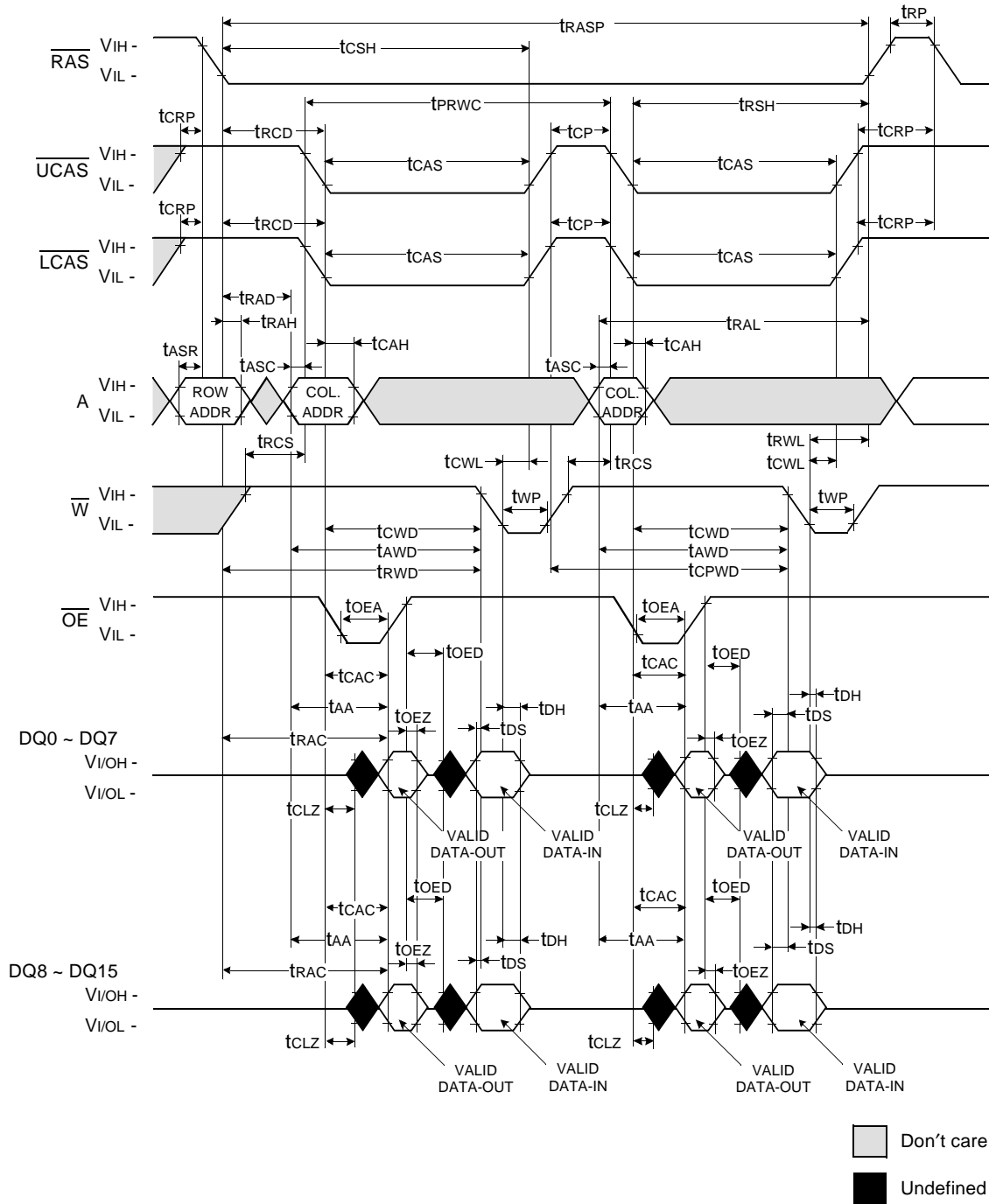

FAST PAGE MODE LOWER BYTE READ - MODIFY - WRITE CYCLE

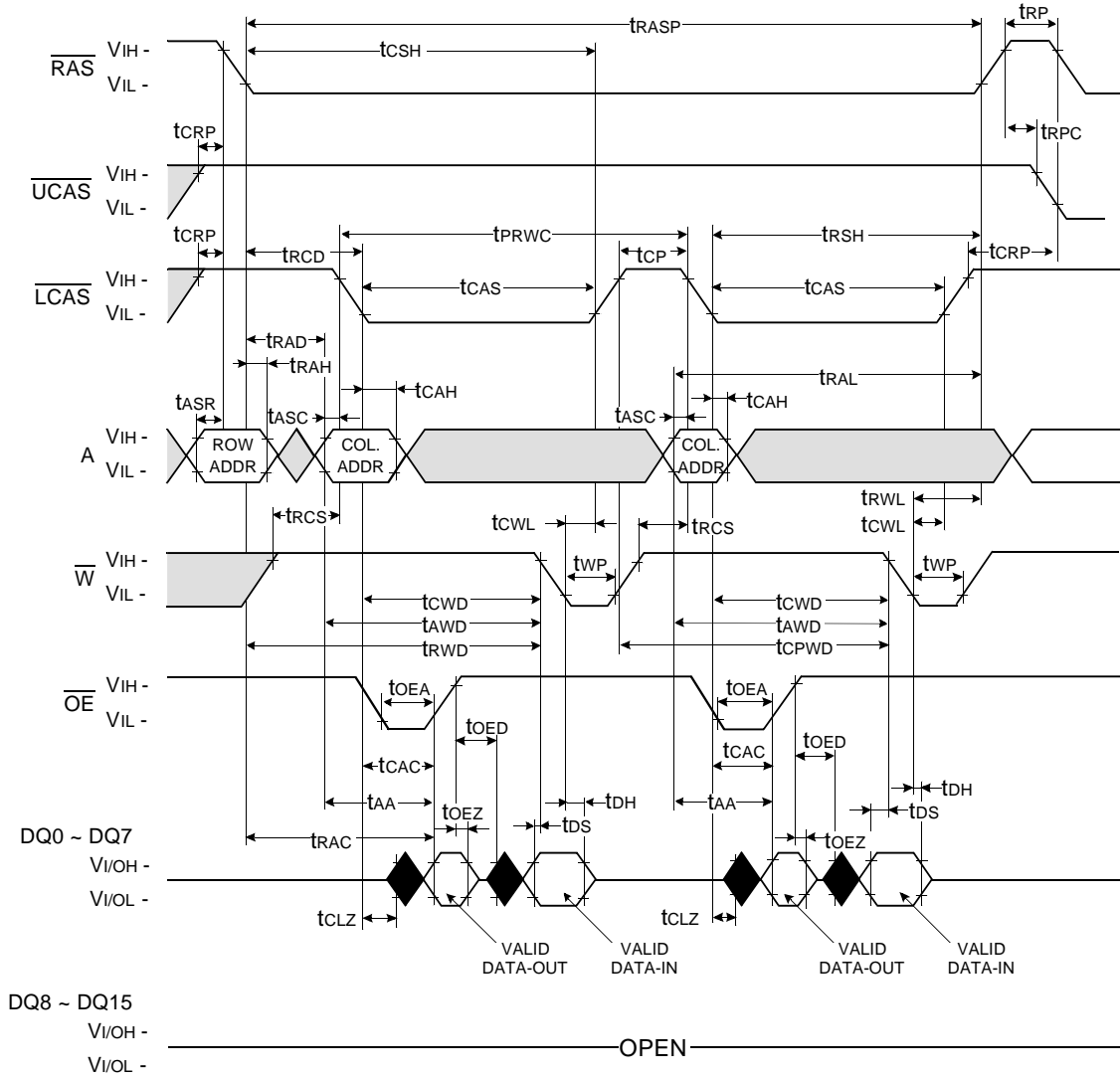

- Don't care
- Undefined



FAST PAGE MODE UPPER BYTE READ - MODIFY - WRITE CYCLE

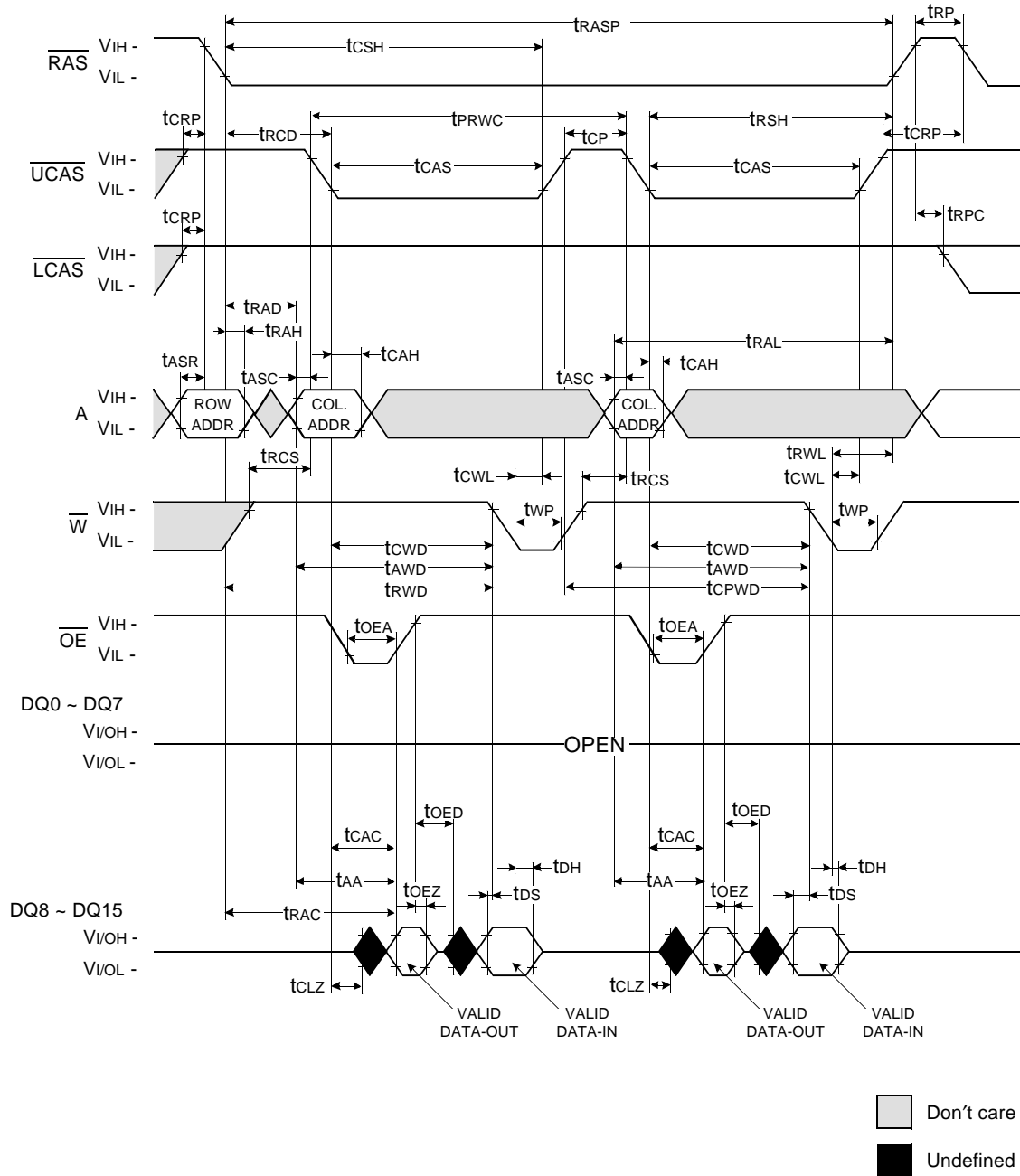

RAS - ONLY REFRESH CYCLE

NOTE : \overline{W} , \overline{OE} , D_{IN} = Don't care

DOUT = OPEN

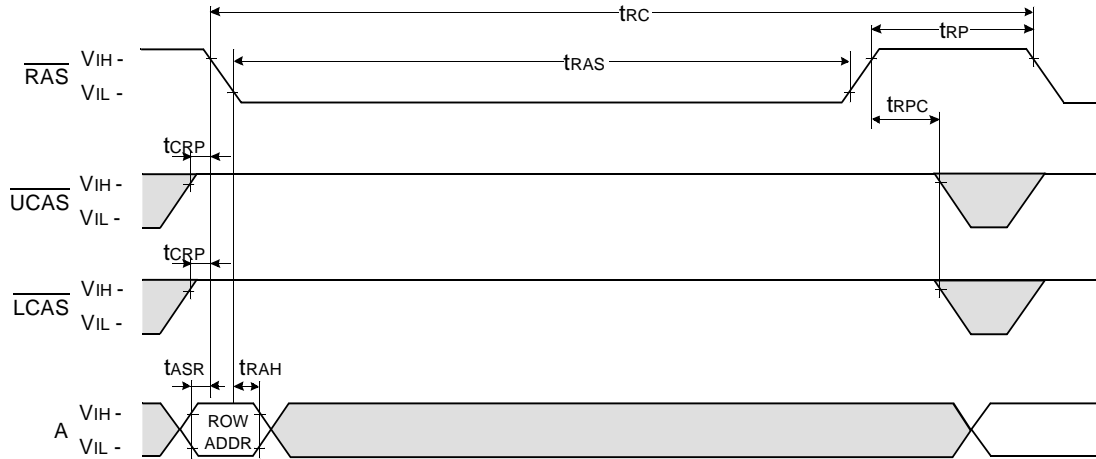

CAS - BEFORE - RAS REFRESH CYCLE

NOTE : \overline{OE} , A = Don't care

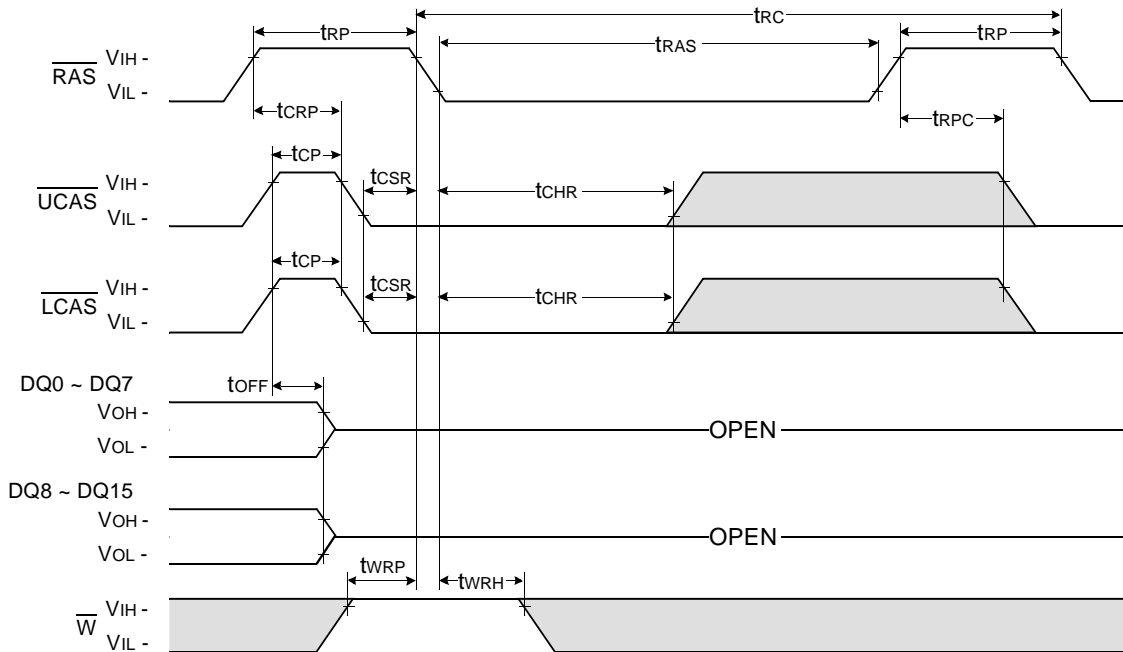

Don't care
 Undefined

HIDDEN REFRESH CYCLE (READ)

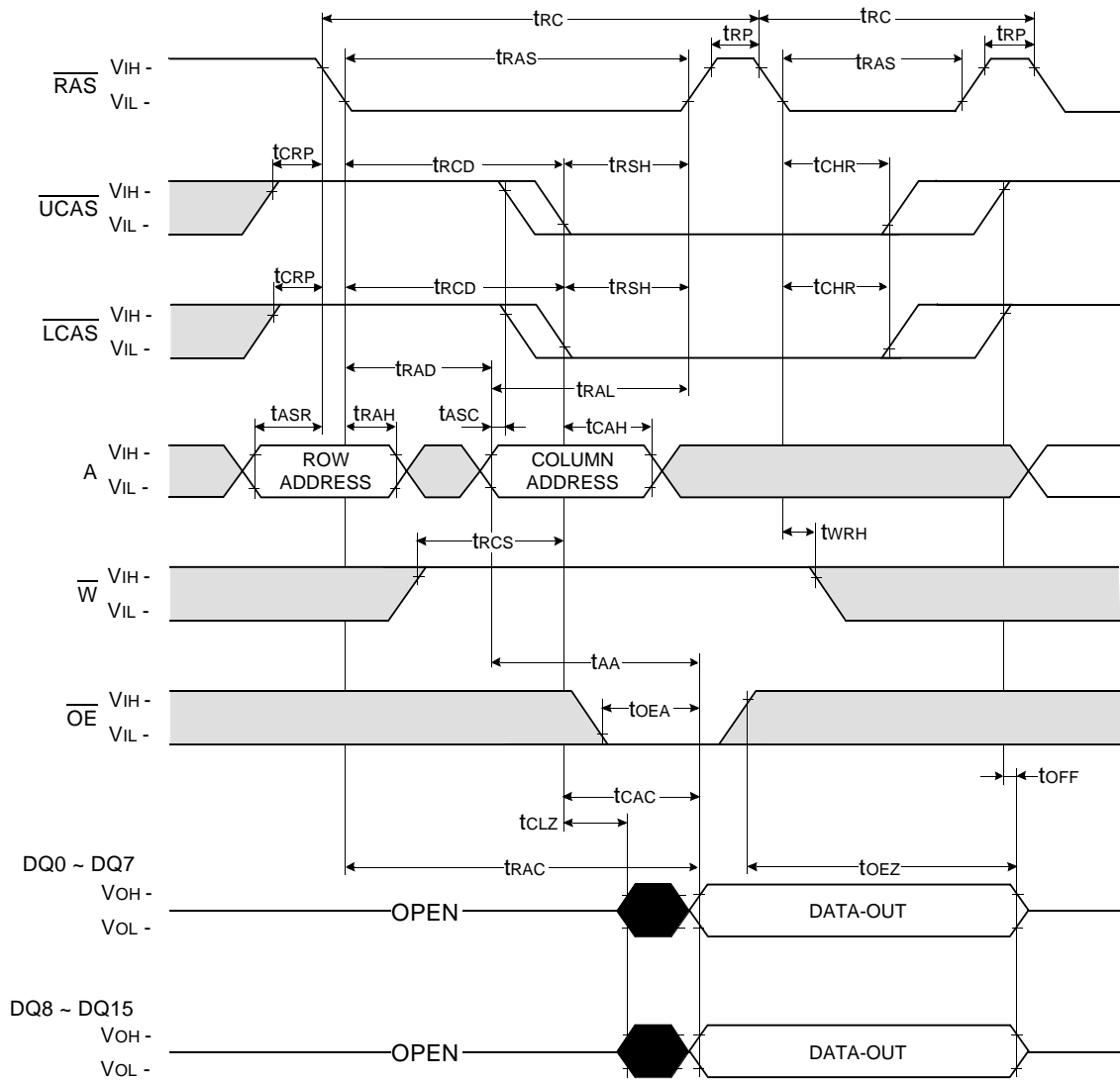

Don't care
 Undefined

HIDDEN REFRESH CYCLE (WRITE)

NOTE : DOUT = OPEN

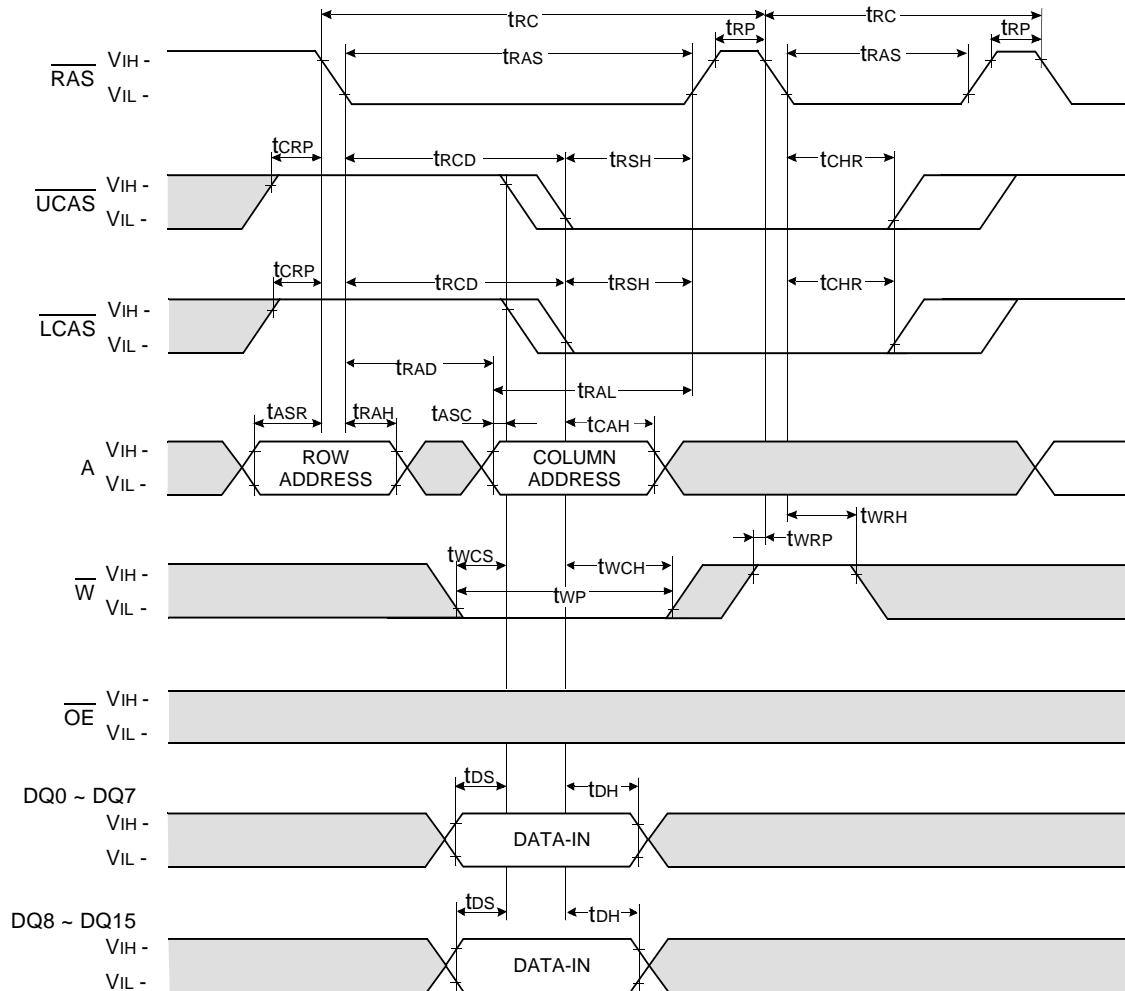

Don't care
 Undefined

CAS - BEFORE - RAS SELF REFRESH CYCLE

NOTE : \overline{OE} , A = Don't care

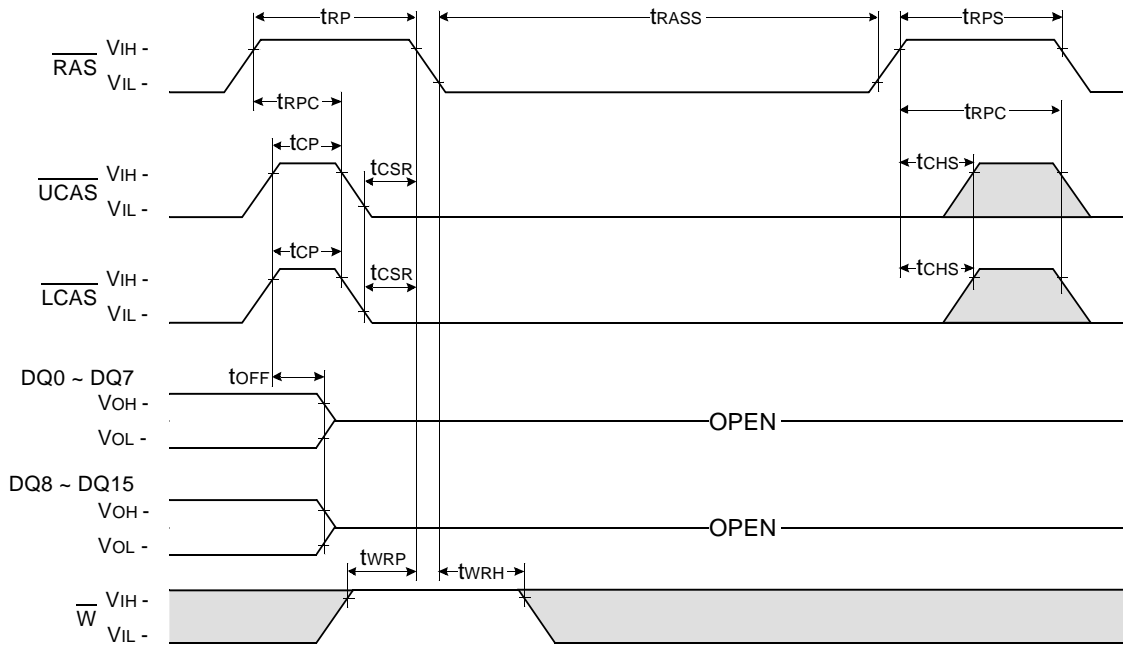

TEST MODE IN CYCLE

NOTE : \overline{OE} , A = Don't care

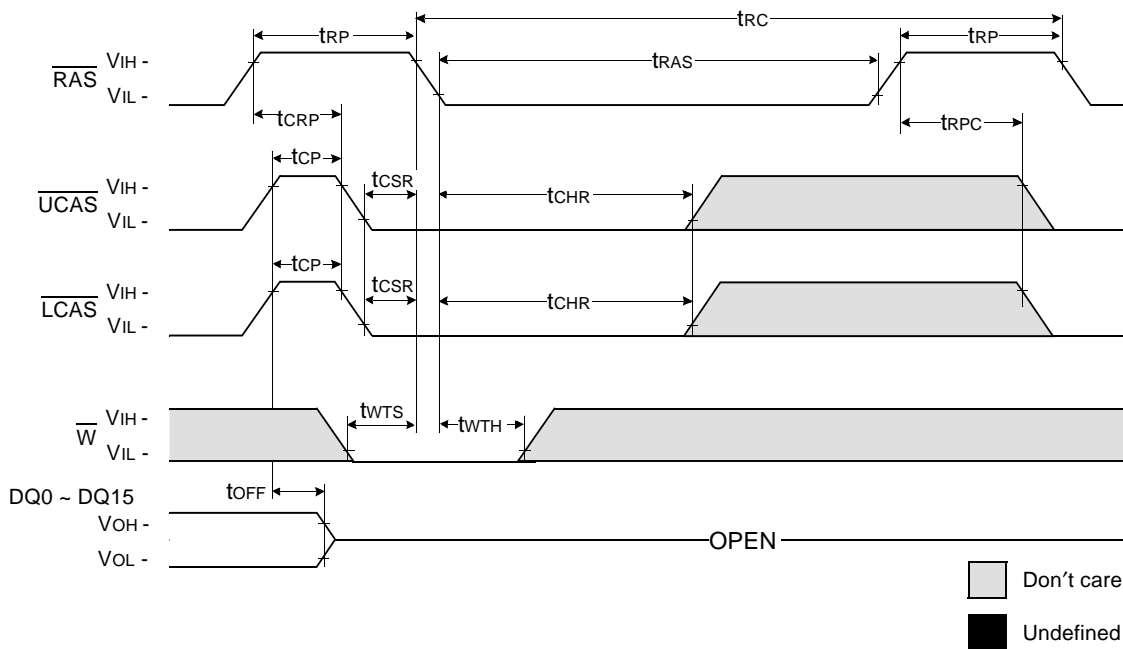

PACKAGE DIMENSION

