

DDR2 Registered SDRAM MODULE

240pin Registered Module based on 512Mb G-die
72-bit ECC

60FBGA with Lead-Free and Halogen-Free
(RoHS compliant)

INFORMATION IN THIS DOCUMENT IS PROVIDED IN RELATION TO SAMSUNG PRODUCTS, AND IS SUBJECT TO CHANGE WITHOUT NOTICE. NOTHING IN THIS DOCUMENT SHALL BE CONSTRUED AS GRANTING ANY LICENSE, EXPRESS OR IMPLIED, BY ESTOPPEL OR OTHERWISE, TO ANY INTELLECTUAL PROPERTY RIGHTS IN SAMSUNG PRODUCTS OR TECHNOLOGY. ALL INFORMATION IN THIS DOCUMENT IS PROVIDED ON AS "AS IS" BASIS WITHOUT GUARANTEE OR WARRANTY OF ANY KIND.

1. For updates or additional information about Samsung products, contact your nearest Samsung office.
2. Samsung products are not intended for use in life support, critical care, medical, safety equipment, or similar applications where Product failure could result in loss of life or personal or physical harm, or any military or defense application, or any governmental procurement to which special terms or provisions may apply.

* Samsung Electronics reserves the right to change products or specification without notice.

Table of Contents

1.0 DDR2 Registered DIMM Ordering Information	4
2.0 Features	4
3.0 Address Configuration	4
4.0 Pin Configurations (Front side/Back side)	5
5.0 Pin Description	5
6.0 Input/Output Functional Description	6
7.0 Functional Block Diagram	7
7.1 512MB, 64Mx72 Module - M393T6553GZ3/M393T6553GZA	7
7.2 1GB, 128Mx72 Module - M393T2953GZ3/M393T2953GZA	8
7.3 1GB, 128Mx72 Module - M393T2950GZ3/M393T2950GZA	9
7.4 2GB, 256Mx72 Module - M393T5750GZ3/M393T5750GZA	10
8.0 Absolute Maximum DC Ratings	11
9.0 AC & DC Operating Conditions	11
9.1 Recommended DC Operating Conditions (SSTL - 1.8)	11
9.2 Operating Temperature Condition	12
9.3 Input DC Logic Level	12
9.4 Input AC Logic Level	12
9.5 AC Input Test Conditions	12
10.0 IDD Specification Parameters Definition	13
11.0 Operating Current Table :	14
11.1 M393T6553GZ3 / M393T6553GZA : 512MB(64Mx8 *9) Module	14
11.2 M393T6553GZ3 / M393T6553GZA : 512MB(64Mx8 *9) Module	14
11.3 M393T2953GZ3 / M393T2953GZA : 1GB(64Mx8 *18) Module	15
11.4 M393T2953GZ3 / M393T2953GZA : 1GB(64Mx8 *18) Module	15
11.5 M393T2950GZ3 / M393T2950GZA : 1GB(128Mx4 *18) Module	16
11.6 M393T2950GZ3 / M393T2950GZA : 1GB(128Mx4 *18) Module	16
11.7 M393T5750GZ3 / M393T5750GZA : 2GB(128Mx4 *36) Module	17
11.8 M393T5750GZ3 / M393T5750GZA : 2GB(128Mx4 *36) Module	17
12.0 Input/Output Capacitance	18
13.0 Electrical Characteristics & AC Timing for DDR2-800/667/533/400	18
13.1 Refresh Parameters by Device Density	18
13.2 Speed Bins and CL, tRCD, tRP, tRC and tRAS for Corresponding Bin	18
13.3 Timing parameters by speed grade (DDR2-800 and DDR2-667).....	19
13.4 Timing parameters by speed grade (DDR2-533 and DDR2-400).....	21
14.0 Physical Dimensions	23
14.1 64Mbx8 based 64Mx72 Module (1 Rank)	23
14.2 64Mbx8/128Mbx4 based 128Mx72 Module (2/1 Ranks)	24
14.3 128Mbx4 based 256Mx72 Module (2 Ranks)	25
15.0 240 Pin DDR2 Registered DIMM Clock Topology	26

Revision History

Revision	Month	Year	History
1.0	July	2008	- Initial Release

1.0 DDR2 Registered DIMM Ordering Information

Part Number	Density	Organization	Component Composition	Number of Rank	Parity Register	Height
M393T6553GZ3-CD5/CC	512MB	64Mx72	64Mx8(K4T51083QG)*9EA	1	X	30.00mm
M393T6553GZA-CF7/E6	512MB	64Mx72	64Mx8(K4T51083QG)*9EA	1	O	30.00mm
M393T2953GZ3-CD5/CC	1GB	128Mx72	64Mx8(K4T51083QG)*18EA	2	X	30.00mm
M393T2953GZA-CF7/E6	1GB	128Mx72	64Mx8(K4T51083QG)*18EA	2	O	30.00mm
M393T2950GZ3-CD5/CC	1GB	128Mx72	128Mx4(K4T51043QG)*18EA	1	X	30.00mm
M393T2950GZA-CF7/E6	1GB	128Mx72	128Mx4(K4T51043QG)*18EA	1	O	30.00mm
M393T5750GZ3-CD5/CC	2GB	256Mx72	128Mx4(K4T51043QG)*36EA	2	X	30.00mm
M393T5750GZA-CF7/E6	2GB	256Mx72	128Mx4(K4T51043QG)*36EA	2	O	30.00mm

Note :

1. "Z" of Part number(11th digit) stands for Lead-Free and RoHS compliant products.
2. "3" of Part number(12th digit) stands for Dummy Pad PCB products.
3. "A" of Part number(12th digit) stands for Parity Register products.

2.0 Features

- Performance range

	F7(DDR2-800)	E6(DDR2-667)	D5(DDR2-533)	CC(DDR2-400)	Unit
Speed@CL3	-	400	400	400	Mbps
Speed@CL4	533	533	533	400	Mbps
Speed@CL5	667	667	533	-	Mbps
Speed@CL6	800	-	-	-	Mbps
CL-tRCD-tRP	6-6-6	5-5-5	4-4-4	3-3-3	CK

- JEDEC standard $V_{DD} = 1.8V \pm 0.1V$ Power Supply
- $V_{DDQ} = 1.8V \pm 0.1V$
- 200 MHz f_{CK} for 400Mb/sec/pin, 267MHz f_{CK} for 533Mb/sec/pin, 333MHz f_{CK} for 667Mb/sec/pin, 400MHz f_{CK} for 800Mb/sec/pin
- 4 Banks
- Posted \overline{CAS}
- Programmable \overline{CAS} Latency: 3, 4, 5, 6
- Programmable Additive Latency: 0, 1, 2, 3, 4 and 5
- Write Latency(WL) = Read Latency(RL) -1
- Burst Length: 4, 8(Interleave/Nibble sequential)
- Programmable Sequential / Interleave Burst Mode
- Bi-directional Differential Data-Strobe (Single-ended data-strobe is an optional feature)
- Off-Chip Driver(OCD) Impedance Adjustment
- On Die Termination with selectable values(50/75/150 ohms or disable)
- Average Refresh Period 7.8us at lower than a $T_{CASE} 85^{\circ}C$, 3.9us at $85^{\circ}C < T_{CASE} \leq 95^{\circ}C$
- Support High Temperature Self-Refresh rate enable feature
- Serial presence detect with EEPROM
- DDR2 SDRAM Package: 60ball FBGA - 128Mx4/64Mx8
- All of base components are Lead-Free, Halogen-Free, and RoHS compliant

Note: For detailed DDR2 SDRAM operation, please refer to Samsung's Device operation & Timing diagram.

3.0 Address Configuration

Organization	Row Address	Column Address	Bank Address	Auto Precharge
128Mx4(512Mb) based Module	A0-A13	A0-A9,A11	BA0-BA1	A10
64Mx8(512Mb) based Module	A0-A13	A0-A9	BA0-BA1	A10

4.0 Pin Configurations (Front side/Back side)

Pin	Front	Pin	Back	Pin	Front	Pin	Back	Pin	Front	Pin	Back	Pin	Front	Pin	Back
1	V _{REF}	121	V _{SS}	31	DQ19	151	V _{SS}	61	A4	181	V _{DDQ}	91	V _{SS}	211	DM5/DQS14
2	V _{SS}	122	DQ4	32	V _{SS}	152	DQ28	62	V _{DDQ}	182	A3	92	DQS5	212	NC/DQS14
3	DQ0	123	DQ5	33	DQ24	153	DQ29	63	A2	183	A1	93	DQS5	213	V _{SS}
4	DQ1	124	V _{SS}	34	DQ25	154	V _{SS}	64	V _{DD}	184	V _{DD}	94	V _{SS}	214	DQ46
5	V _{SS}	125	DM0/DQS9	35	V _{SS}	155	DM3/DQS12	KEY				95	DQ42	215	DQ47
6	DQS0	126	NC/DQS9	36	DQS3	156	NC/DQS12	65	V _{SS}	185	CK0	96	DQ43	216	V _{SS}
7	DQS0	127	V _{SS}	37	DQS3	157	V _{SS}	66	V _{SS}	186	CK0	97	V _{SS}	217	DQ52
8	V _{SS}	128	DQ6	38	V _{SS}	158	DQ30	67	V _{DD}	187	V _{DD}	98	DQ48	218	DQ53
9	DQ2	129	DQ7	39	DQ26	159	DQ31	68	NC/Par_In	188	A0	99	DQ49	219	V _{SS}
10	DQ3	130	V _{SS}	40	DQ27	160	V _{SS}	69	V _{DD}	189	V _{DD}	100	V _{SS}	220	RFU
11	V _{SS}	131	DQ12	41	V _{SS}	161	CB4	70	A10/AP	190	BA1	101	SA2	221	RFU
12	DQ8	132	DQ13	42	CB0	162	CB5	71	BA0	191	V _{DDQ}	102	NC(TEST)	222	V _{SS}
13	DQ9	133	V _{SS}	43	CB1	163	V _{SS}	72	V _{DDQ}	192	RAS	103	V _{SS}	223	DM6/DQS15
14	V _{SS}	134	DM1/DQS10	44	V _{SS}	164	DM8/DQS17	73	WE	193	S0	104	DQS6	224	NC/DQS15
15	DQS1	135	NC/DQS10	45	DQS8	165	NC/DQS17	74	CAS	194	V _{DDQ}	105	DQS6	225	V _{SS}
16	DQS1	136	V _{SS}	46	DQS8	166	V _{SS}	75	V _{DDQ}	195	ODT0	106	V _{SS}	226	DQ54
17	V _{SS}	137	RFU	47	V _{SS}	167	CB6	76	S1 ⁴	196	A13	107	DQ50	227	DQ55
18	RESET	138	RFU	48	CB2	168	CB7	77	ODT1	197	V _{DD}	108	DQ51	228	V _{SS}
19	NC	139	V _{SS}	49	CB3	169	V _{SS}	78	V _{DDQ}	198	V _{SS}	109	V _{SS}	229	DQ60
20	V _{SS}	140	DQ14	50	V _{SS}	170	V _{DDQ}	79	V _{SS}	199	DQ36	110	DQ56	230	DQ61
21	DQ10	141	DQ15	51	V _{DDQ}	171	CKE1 ⁴	80	DQ32	200	DQ37	111	DQ57	231	V _{SS}
22	DQ11	142	V _{SS}	52	CKE0	172	V _{DD}	81	DQ33	201	V _{SS}	112	V _{SS}	232	DM7/DQS16
23	V _{SS}	143	DQ20	53	V _{DD}	173	NC	82	V _{SS}	202	DM4/DQS13	113	DQS7	233	NC/DQS16
24	DQ16	144	DQ21	54	NC	174	NC	83	DQS4	203	NC/DQS13	114	DQS7	234	V _{SS}
25	DQ17	145	V _{SS}	55	NC/Err_Out	175	V _{DDQ}	84	DQS4	204	V _{SS}	115	V _{SS}	235	DQ62
26	V _{SS}	146	DM2/DQS11	56	V _{DDQ}	176	A12	85	V _{SS}	205	DQ38	116	DQ58	236	DQ63
27	DQS2	147	NC/DQS11	57	A11	177	A9	86	DQ34	206	DQ39	117	DQ59	237	V _{SS}
28	DQS2	148	V _{SS}	58	A7	178	V _{DD}	87	DQ35	207	V _{SS}	118	V _{SS}	238	V _{DDSPD}
29	V _{SS}	149	DQ22	59	V _{DD}	179	A8	88	V _{SS}	208	DQ44	119	SDA	239	SA0
30	DQ18	150	DQ23	60	A5	180	A6	89	DQ40	209	DQ45	120	SCL	240	SA1
								90	DQ41	210	V _{SS}				

NC = No Connect, RFU = Reserved for Future Use

1. RESET (Pin 18) is connected to both OE of PLL and Reset of register.
2. The Test pin (Pin 102) is reserved for bus analysis probes and is not connected on normal memory modules (DIMMs)
3. NC/Err_Out (Pin 55) and NC/Par_In (Pin 68) are for optional function to check address and command parity.
4. CKE1,S1 Pin is used for double side Registered DIMM.

5.0 Pin Description

Pin Name	Description	Pin Name	Description
CK0	Clock Inputs, positive line	ODT0~ODT1	On die termination
CK0	Clock inputs, negative line	DQ0~DQ63	Data Input/Output
CKE0, CKE1	Clock Enables	CB0~CB7	Data check bits Input/Output
RAS	Row Address Strobe	DQS0~DQS8	Data strobes
CAS	Column Address Strobe	DQS0~DQS8	Data strobes, negative line
WE	Write Enable	DM(0~8),DQS(9~17)	Data Masks / Data strobes (Read)
S0, S1	Chip Selects	DQS9~DQS17	Data strobes (Read), negative line
A0~A9, A11~A13	Address Inputs	RFU	Reserved for Future Use
A10/AP	Address Input/Autoprecharge	NC	No Connect
BA0, BA1	DDR2 SDRAM Bank Address	TEST	Memory bus test tool (Not Connect and Not Useable on DIMMs)
SCL	Serial Presence Detect (SPD) Clock Input	V _{DD}	Core Power
SDA	SPD Data Input/Output	V _{DDQ}	I/O Power
SA0~SA2	SPD address	V _{SS}	Ground
Par_In	Parity bit for the Address and Control bus	V _{REF}	Input/Output Reference
Err_Out	Parity error found in the Address and Control bus	V _{DDSPD}	SPD Power
RESET	Register and PLL control pin		

*The V_{DD} and V_{DDQ} pins are tied to the single power-plane on PCB.

6.0 Input/Output Functional Description

Symbol	Type	Function
CK0	Input	Positive line of the differential pair of system clock inputs that drives input to the on-DIMM PLL.
$\overline{\text{CK0}}$	Input	Negative line of the differential pair of system clock inputs that drives the input to the on-DIMM PLL.
CKE0~CKE1	Input	Activates the SDRAM CK signal when high and deactivates the CK signal when low. By deactivating the clocks, CKE low initiates the Power Down mode, or the Self Refresh mode.
$\overline{\text{S0}}\sim\overline{\text{S1}}$	Input	Enables the associated SDRAM command decoder when low and disables decoder when high. When decoder is disabled, new commands are ignored but previous operations continue. These input signals also disable all outputs (except CKE and ODT) of the register(s) on the DIMM when both inputs are high.
ODT0~ODT1	Input	I/O bus impedance control signals.
$\overline{\text{RAS}}$, $\overline{\text{CAS}}$, $\overline{\text{WE}}$	Input	When sampled at the positive rising edge of the clock, $\overline{\text{CAS}}$, $\overline{\text{RAS}}$, and $\overline{\text{WE}}$ define the operation to be executed by the SDRAM.
V _{REF}	Supply	Reference voltage for SSTL_18 inputs
V _{DDQ}	Supply	Isolated power supply for the DDR SDRAM output buffers to provide improved noise immunity
BA0~BA1	Input	Selects which SDRAM bank of four is activated.
A0~A9,A10/AP A11~A13	Input	During a Bank Activate command cycle, Address defines the row address. During a Read or Write command cycle, Address defines the column address. In addition to the column address, AP is used to invoke autoprecharge operation at the end of the burst read or write cycle. If AP is high, autoprecharge is selected and BA0, BA1 defines the bank to be precharged. If AP is low, autoprecharge is disabled. During a Precharge command cycle, AP is used in conjunction with BA0, BA1 to control which bank(s) to precharge. If AP is high, all banks will be precharged regardless of the state of BA0 or BA1. If AP is low, BA0 and BA1 are used to define which bank to precharge.
DQ0~63, CB0~CB7	In/Out	Data and Check Bit Input/Output pins
DM0~DM8	Input	Masks write data when high, issued concurrently with input data. Both DM and DQ have a write latency of one clock once the write command is registered into the SDRAM.
V _{DD} , V _{SS}	Supply	Power and ground for the DDR SDRAM input buffers and core logic
DQS0~DQS17	In/Out	Positive line of the differential data strobe for input and output data.
$\overline{\text{DQS0}}\sim\overline{\text{DQS17}}$	In/Out	Negative line of the differential data strobe for input and output data.
SA0~SA2	Input	These signals are tied at the system planar to either V _{SS} or V _{DDSPD} to configure the serial SPD EEPROM address range.
SDA	In/Out	This bidirectional pin is used to transfer data into or out of the SPD EEPROM. A resistor must be connected from the SDA bus line to V _{DDSPD} to act as a pullup.
SCL	Input	This signal is used to clock data into and out of the SPD EEPROM. A resistor may be connected from the SCL bus time to V _{DDSPD} to act as a pullup.
V _{DDSPD}	Supply	Serial EEPROM positive power supply (wired to a separate power pin at the connector which supports from 1.7 Volt to 3.6 Volt operation).
$\overline{\text{RESET}}$	Input	The $\overline{\text{RESET}}$ pin is connected to the RST pin on the register and to the OE pin on the PLL. When low, all register outputs will be driven low and the PLL clocks to the DRAMs and register(s) will be set to low level (The PLL will remain synchronized with the input clock)
Par_In	Input	Parity bit for the Address and Control bus. ("1 " : Odd, "0 " : Even)
$\overline{\text{Err_Out}}$	Input	Parity error found in the Address and Control bus
TEST	In/Out	Used by memory bus analysis tools (unused on memory DIMMs)

7.0 Functional Block Diagram

7.1 512MB, 64Mx72 Module - M393T6553GZ3/M393T6553GZA

(populated as 1 rank of x8 DDR2 SDRAMs)

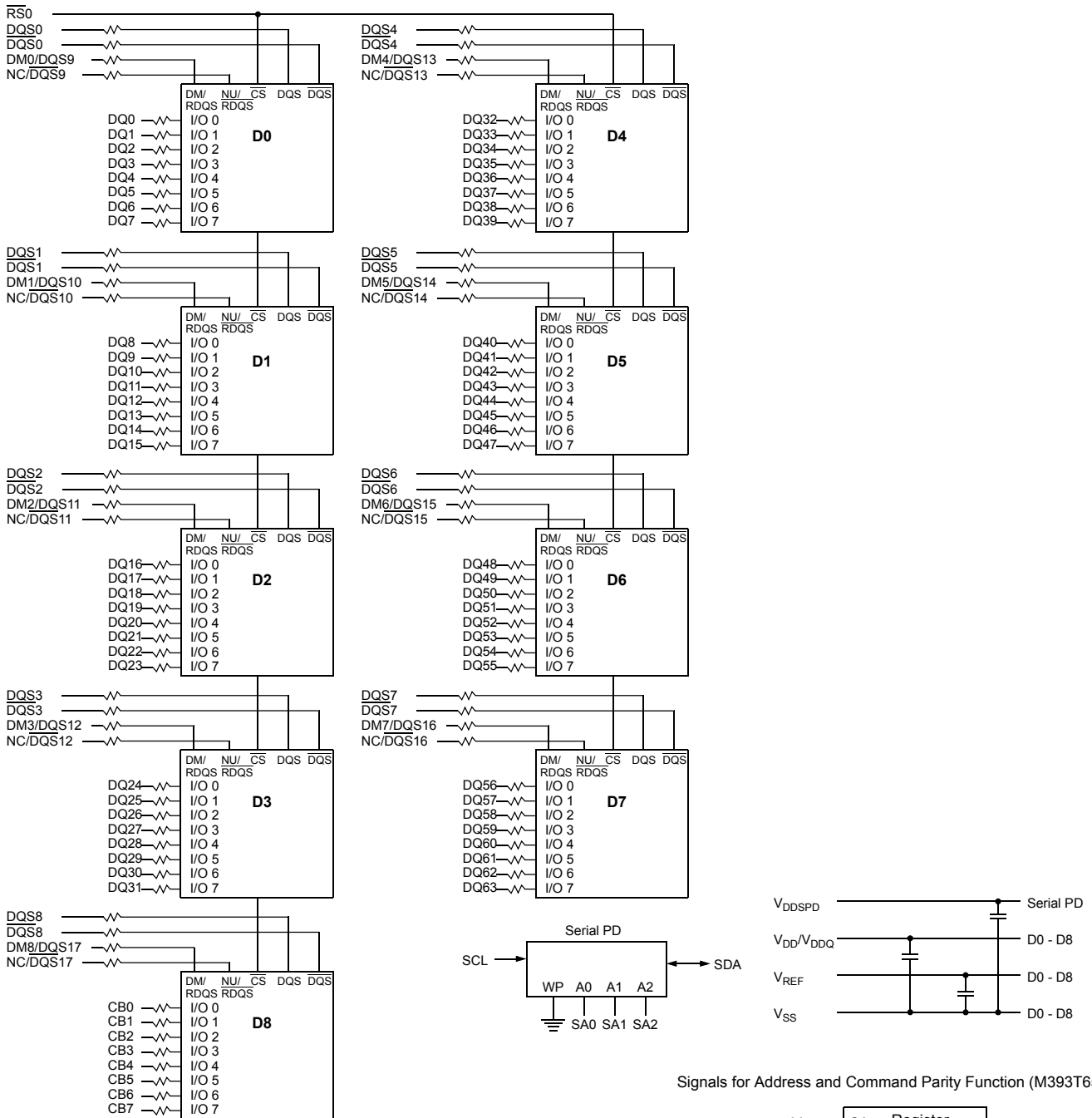

Signals for Address and Command Parity Function (M393T6553GZA)

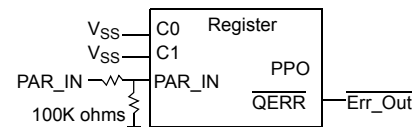

The resistors on Par_In, A13, A14, A15, BA2 and the signal line of Err_Out refer to the section: "Register Options for Unused Address inputs"

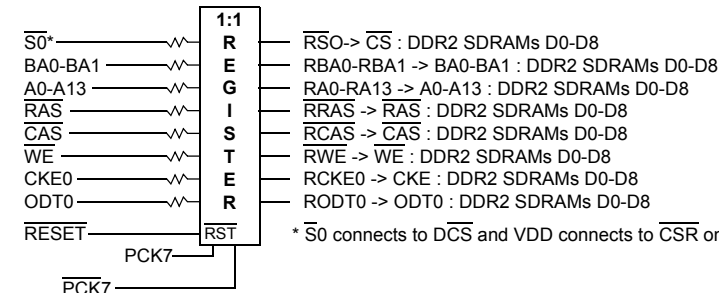

Note :
 1. DQ-to-I/O wiring may be changed within a byte.
 2. DQ/DQS/DM/CKE/S relationships must be maintained as shown.
 3. Unless otherwise noted, resistor values are 22 Ohms ± 5%

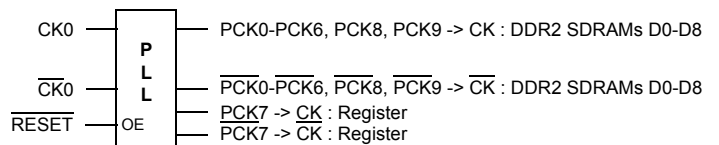

7.2 1GB, 128Mx72 Module - M393T2953GZ3 / M393T2953GZA

(populated as 2 rank of x8 DDR2 SDRAMs)

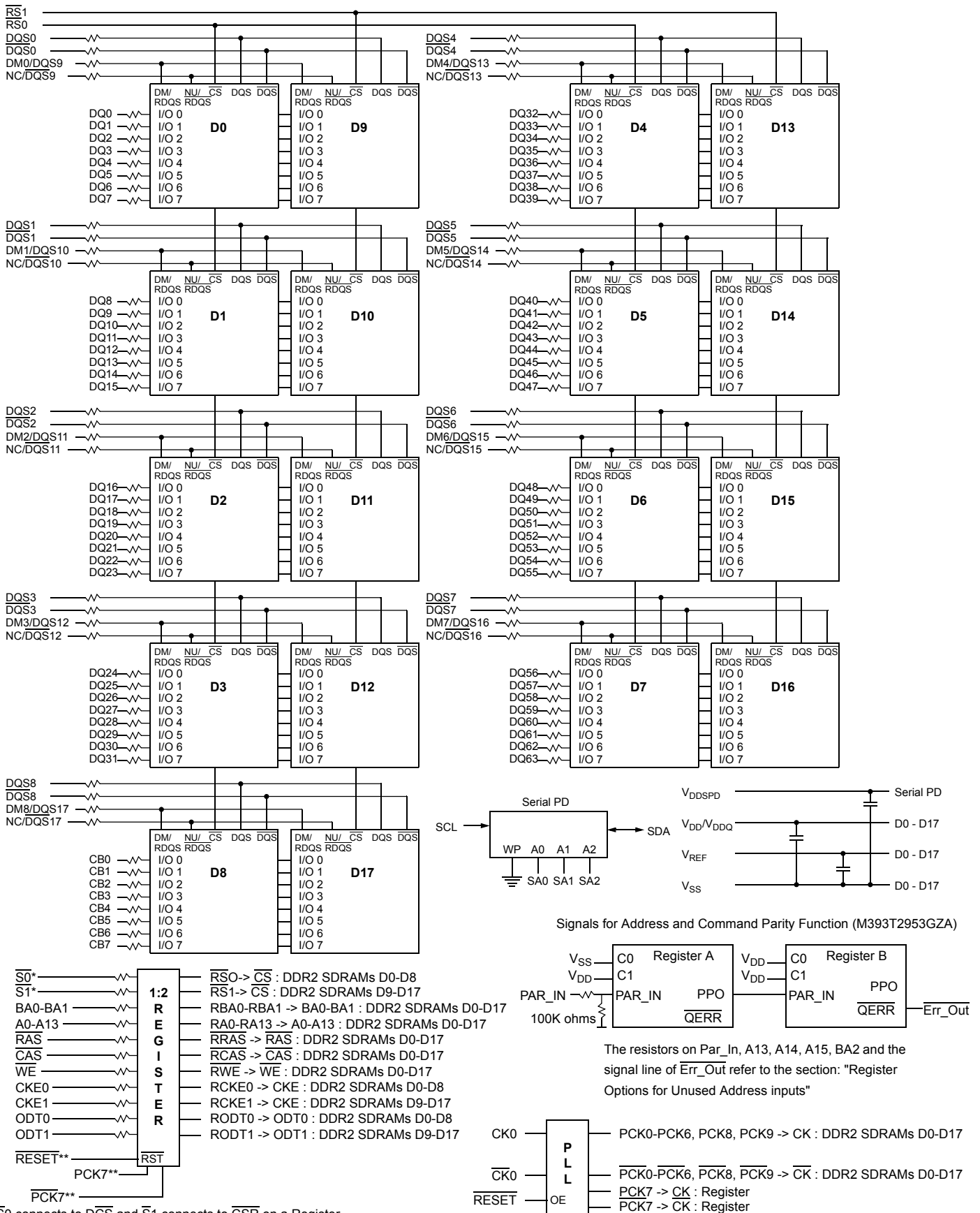

* $\overline{S0}$ connects to \overline{DCS} and $\overline{S1}$ connects to \overline{CSR} on a Register, $\overline{S1}$ connects to \overline{DCS} and $\overline{S0}$ connects to \overline{CSR} on another Register.

** \overline{RESET} , $\overline{PCK7}$ and $\overline{PCK7}$ connects to both Registers. Other signals connect to one of two Registers.

Note :

1. DQ-to-I/O wiring may be changed per nibble.
2. Unless otherwise noted, resistor values are 22 Ohms \pm 5%
3. RS0 and RS1 alternate between the back and front sides of the DIMM

7.3 1GB, 128Mx72 Module - M393T2950GZ3/M393T2950GZA

(populated as 1 rank of x4 DDR2 SDRAMs)

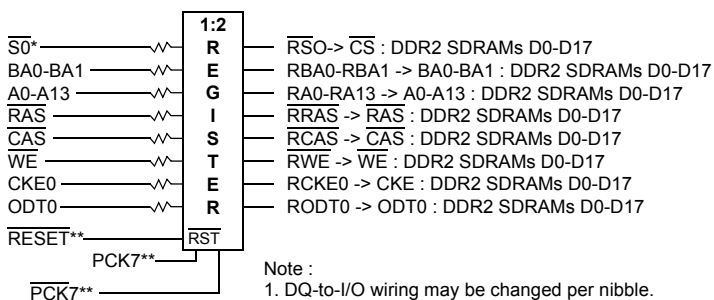
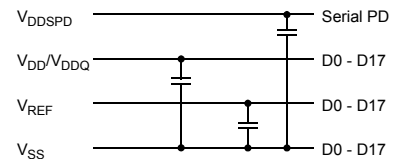
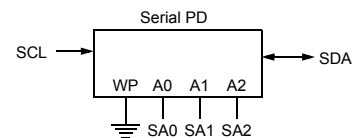
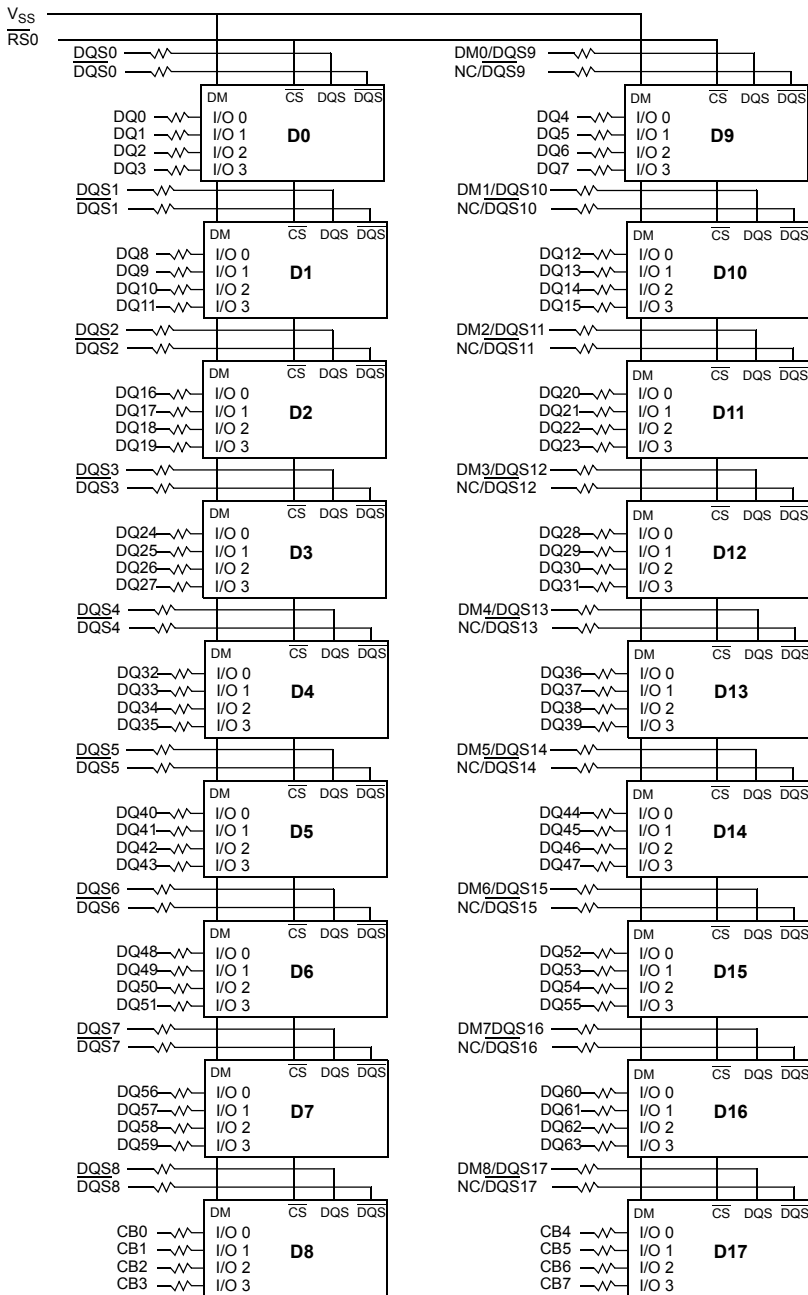

Note :
1. DQ-to-I/O wiring may be changed per nibble.
2. Unless otherwise noted, resistor values are 22 Ohms ± 5%

Signals for Address and Command Parity Function (M393T2950GZA)

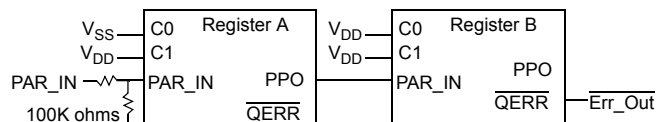

The resistors on Par_In, A13, A14, A15, BA2 and the signal line of Err_Out refer to the section: "Register Options for Unused Address inputs"

* S0 connects to DCS of Register1 and CSR of Register2. CSR of register 1 and DCS of register 2 connects to VDD.

** RESET, PCK7 and PCK7 connects to both Registers. Other signals connect to one of two Registers. S1, CKE1 and ODT1 are NC.

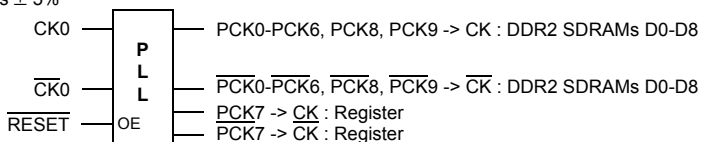

7.4 2GB, 256Mx72 Module - M393T5750GZ3/M393T5750GZA

(populated as 2 rank of x4 DDR2 SDRAMs)

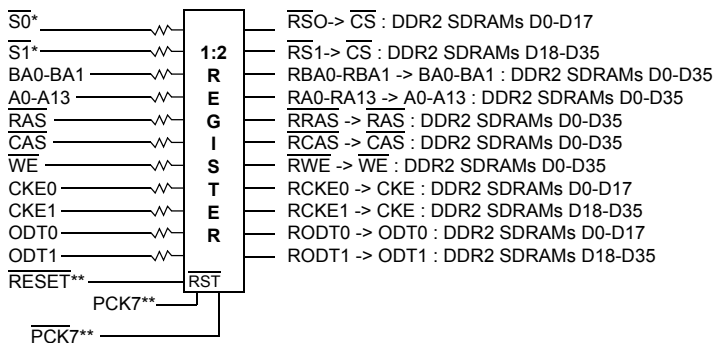
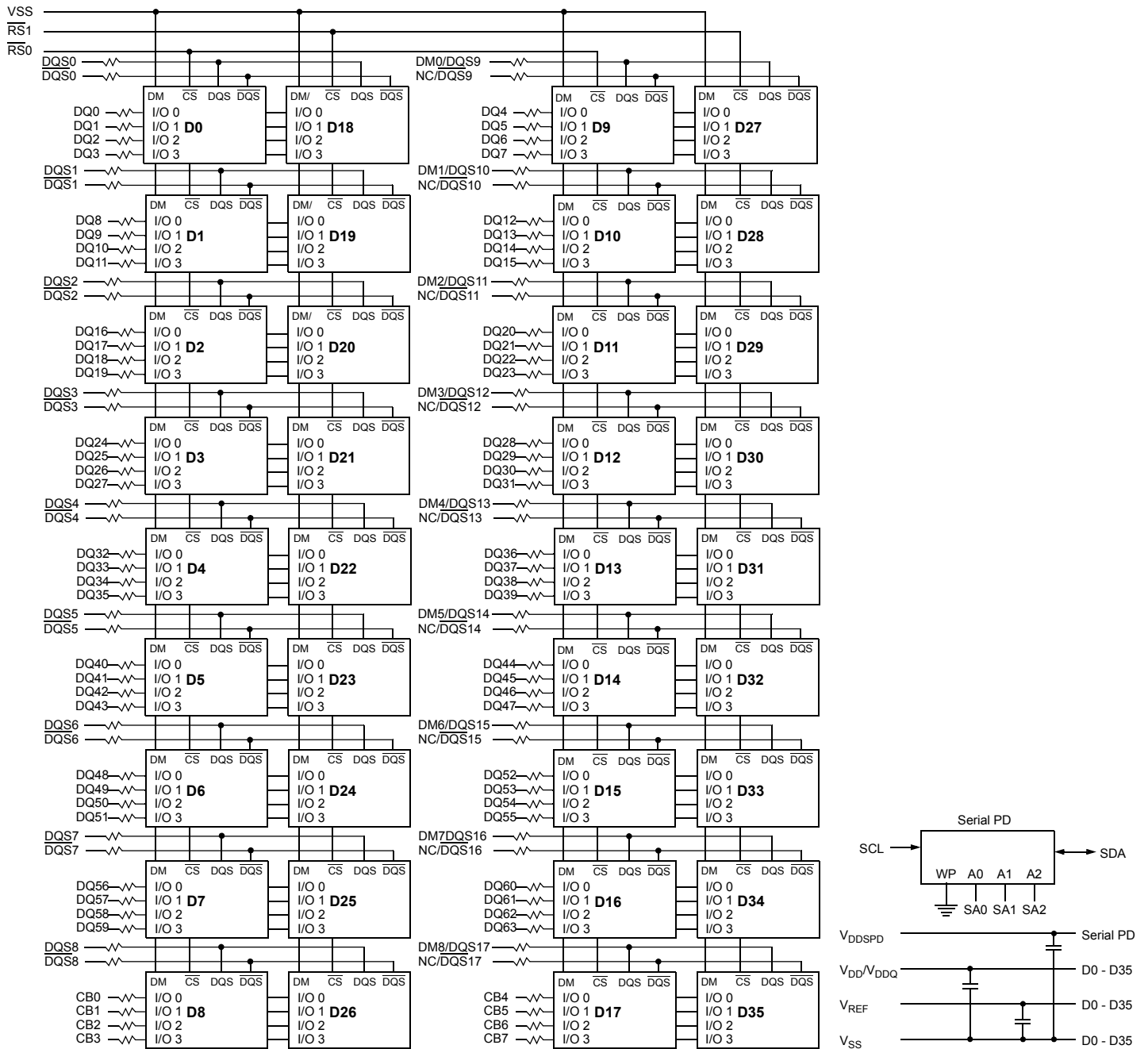

Signals for Address and Command Parity Function (M393T5750GZA)

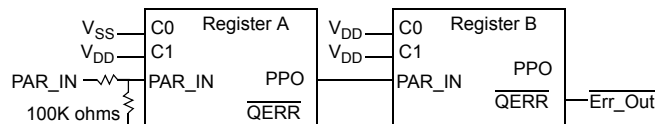

The resistors on Par_In, A13, A14, A15, BA2 and the signal line of Err_Out refer to the section: "Register Options for Unused Address inputs"

* S0 connects to DCS and S1 connects to CSR on a pair of Registers, S1 connects to DCS and S0 connects to CSR on another pair of Registers.

** RESET, PCK7 and PCK7 connects to all Registers. Other signals connect to one pair of four Registers.

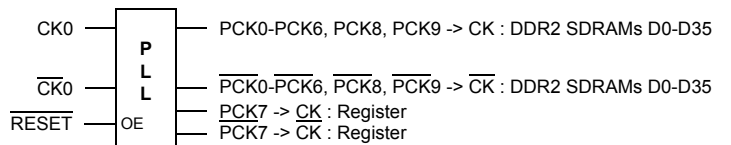

8.0 Absolute Maximum DC Ratings

Symbol	Parameter	Rating	Units	Notes
V _{DD}	Voltage on V _{DD} pin relative to V _{SS}	- 1.0 V ~ 2.3 V	V	1
V _{DDQ}	Voltage on V _{DDQ} pin relative to V _{SS}	- 0.5 V ~ 2.3 V	V	1
V _{DDL}	Voltage on V _{DDL} pin relative to V _{SS}	- 0.5 V ~ 2.3 V	V	1
V _{IN} , V _{OUT}	Voltage on any pin relative to V _{SS}	- 0.5 V ~ 2.3 V	V	1
T _{STG}	Storage Temperature	-55 to +100	°C	1, 2

Note :

1. Stresses greater than those listed under “Absolute Maximum Ratings” may cause permanent damage to the device. This is a stress rating only and functional operation of the device at these or any other conditions above those indicated in the operational sections of this specification is not implied. Exposure to absolute maximum rating conditions for extended periods may affect reliability.
2. Storage Temperature is the case surface temperature on the center/top side of the DRAM. For the measurement conditions, please refer to JESD51-2 standard.

9.0 AC & DC Operating Conditions

9.1 Recommended DC Operating Conditions (SSTL - 1.8)

Symbol	Parameter	Rating			Units	Notes
		Min.	Typ.	Max.		
V _{DD}	Supply Voltage	1.7	1.8	1.9	V	
V _{DDL}	Supply Voltage for DLL	1.7	1.8	1.9	V	4
V _{DDQ}	Supply Voltage for Output	1.7	1.8	1.9	V	4
V _{REF}	Input Reference Voltage	0.49*V _{DDQ}	0.50*V _{DDQ}	0.51*V _{DDQ}	mV	1,2
V _{TT}	Termination Voltage	V _{REF} -0.04	V _{REF}	V _{REF} +0.04	V	3

Note : There is no specific device V_{DD} supply voltage requirement for SSTL-1.8 compliance. However under all conditions V_{DDQ} must be less than or equal to V_{DD}.

1. The value of V_{REF} may be selected by the user to provide optimum noise margin in the system. Typically the value of V_{REF} is expected to be about 0.5 x V_{DDQ} of the transmitting device and V_{REF} is expected to track variations in V_{DDQ}.
2. Peak to peak AC noise on V_{REF} may not exceed +/-2% V_{REF}(DC).
3. V_{TT} of transmitting device must track V_{REF} of receiving device.
4. AC parameters are measured with V_{DD}, V_{DDQ} and V_{DDL} tied together.

9.2 Operating Temperature Condition

Symbol	Parameter	Rating	Units	Notes
T _{OPER}	Operating Temperature	0 to 95	°C	1, 2

Note :

1. Operating Temperature is the case surface temperature on the center/top side of the DRAM. For the measurement conditions, please refer to JESD51.2 standard.
2. At 85 - 95 °C operation temperature range, doubling refresh commands in frequency to a 32ms period (tREFI=3.9 us) is required, and to enter to self refresh mode at this temperature range, an EMRS command is required to change internal refresh rate.

9.3 Input DC Logic Level

Symbol	Parameter	Min.	Max.	Units	Notes
V _{IH(DC)}	DC input logic high	V _{REF} + 0.125	V _{DDQ} + 0.3	V	
V _{IL(DC)}	DC input logic low	- 0.3	V _{REF} - 0.125	V	

9.4 Input AC Logic Level

Symbol	Parameter	DDR2-400, DDR2-533		DDR2-667, DDR2-800		Units
		Min.	Max.	Min.	Max.	
V _{IH(AC)}	AC input logic high	V _{REF} + 0.250	-	V _{REF} + 0.200		V
V _{IL(AC)}	AC input logic low	-	V _{REF} - 0.250		V _{REF} - 0.200	V

9.5 AC Input Test Conditions

Symbol	Condition	Value	Units	Notes
V _{REF}	Input reference voltage	0.5 * V _{DDQ}	V	1
V _{SWING(MAX)}	Input signal maximum peak to peak swing	1.0	V	1
SLEW	Input signal minimum slew rate	1.0	V/ns	2, 3

Note :

1. Input waveform timing is referenced to the input signal crossing through the V_{IH/IL(AC)} level applied to the device under test.
2. The input signal minimum slew rate is to be maintained over the range from V_{REF} to V_{IH(AC)} min for rising edges and the range from V_{REF} to V_{IL(AC)} max for falling edges as shown in the below figure.
3. AC timings are referenced with input waveforms switching from V_{IL(AC)} to V_{IH(AC)} on the positive transitions and V_{IH(AC)} to V_{IL(AC)} on the negative transitions.

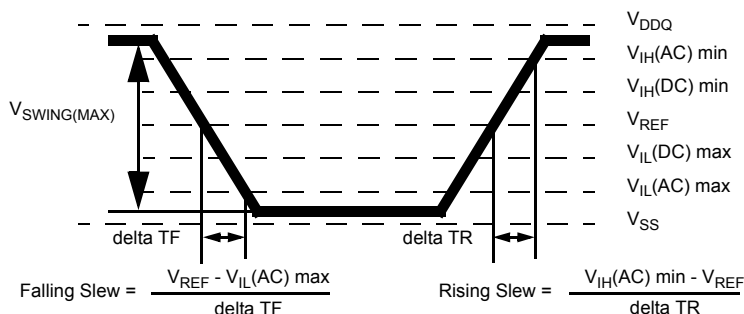

< AC Input Test Signal Waveform >

10.0 IDD Specification Parameters Definition

(IDD values are for full operating range of Voltage and Temperature)

Symbol	Proposed Conditions	Units	Note
IDD0	Operating one bank active-precharge current; tCK = tCK(IDD), tRC = tRC(IDD), tRAS = tRASmin(IDD); CKE is HIGH, \overline{CS} is HIGH between valid commands; Address bus inputs are SWITCHING; Data bus inputs are SWITCHING	mA	
IDD1	Operating one bank active-read-precharge current; IOUT = 0mA; BL = 4, CL = CL(IDD), AL = 0; tCK = tCK(IDD), tRC = tRC(IDD), tRAS = tRASmin(IDD), tRCD = tRCD(IDD); CKE is HIGH, \overline{CS} is HIGH between valid commands; Address bus inputs are SWITCHING; Data pattern is same as IDD4W	mA	
IDD2P	Precharge power-down current; All banks idle; tCK = tCK(IDD); CKE is LOW; Other control and address bus inputs are STABLE; Data bus inputs are FLOATING	mA	
IDD2Q	Precharge quiet standby current; All banks idle; tCK = tCK(IDD); CKE is HIGH, \overline{CS} is HIGH; Other control and address bus inputs are STABLE; Data bus inputs are FLOATING	mA	
IDD2N	Precharge standby current; All banks idle; tCK = tCK(IDD); CKE is HIGH, \overline{CS} is HIGH; Other control and address bus inputs are SWITCHING; Data bus inputs are SWITCHING	mA	
IDD3P	Active power-down current; All banks open; tCK = tCK(IDD); CKE is LOW; Other control and address bus inputs are STABLE; Data bus inputs are FLOATING	Fast PDN Exit MRS(12) = 0mA	mA
		Slow PDN Exit MRS(12) = 1mA	mA
IDD3N	Active standby current; All banks open; tCK = tCK(IDD), tRAS = tRASmax(IDD), tRP = tRP(IDD); CKE is HIGH, \overline{CS} is HIGH between valid commands; Other control and address bus inputs are SWITCHING; Data bus inputs are SWITCHING	mA	
IDD4W	Operating burst write current; All banks open, Continuous burst writes; BL = 4, CL = CL(IDD), AL = 0; tCK = tCK(IDD), tRAS = tRASmax(IDD), tRP = tRP(IDD); CKE is HIGH, \overline{CS} is HIGH between valid commands; Address bus inputs are SWITCHING; Data bus inputs are SWITCHING	mA	
IDD4R	Operating burst read current; All banks open, Continuous burst reads, IOUT = 0mA; BL = 4, CL = CL(IDD), AL = 0; tCK = tCK(IDD), tRAS = tRASmax(IDD), tRP = tRP(IDD); CKE is HIGH, \overline{CS} is HIGH between valid commands; Address bus inputs are SWITCHING; Data pattern is same as IDD4W	mA	
IDD5B	Burst auto refresh current; tCK = tCK(IDD); Refresh command at every tRFC(IDD) interval; CKE is HIGH, \overline{CS} is HIGH between valid commands; Other control and address bus inputs are SWITCHING; Data bus inputs are SWITCHING	mA	
IDD6	Self refresh current; CK and \overline{CK} at 0V; CKE \leq 0.2V; Other control and address bus inputs are FLOATING; Data bus inputs are FLOATING	Normal	mA
		Low Power	mA
IDD7	Operating bank interleave read current; All bank interleaving reads, IOUT = 0mA; BL = 4, CL = CL(IDD), AL = tRCD(IDD)-1*tCK(IDD); tCK = tCK(IDD), tRC = tRC(IDD), tRRD = tRRD(IDD), tFAW = tFAW(IDD), tRCD = 1*tCK(IDD); CKE is HIGH, \overline{CS} is HIGH between valid commands; Address bus inputs are STABLE during DESELECTs; Data pattern is same as IDD4R; Refer to the following page for detailed timing conditions	mA	

11.0 Operating Current Table :

11.1 M393T6553GZ3 / M393T6553GZA : 512MB(64Mx8 *9) Module

(TA=0°C, V_{DD}= 1.9V)

Symbol	F7(800@CL=6)	E6(667@CL=5)	D5(533@CL=4)	CC(400@CL=3)	Units	Notes
IDD0	765	675	675	630	mA	
IDD1	855	810	765	765	mA	
IDD2P	72	72	72	72	mA	
IDD2Q	315	315	270	270	mA	
IDD2N	360	360	315	315	mA	
IDD3P-F	270	270	270	270	mA	
IDD3P-S	108	108	108	108	mA	
IDD3N	540	495	450	450	mA	
IDD4W	990	900	765	720	mA	
IDD4R	1260	1170	945	855	mA	
IDD5B	990	945	945	900	mA	
IDD6*	72	72	72	72	mA	
IDD7	1890	1575	1575	1575	mA	

* Module IDD was calculated on the basis of component IDD and can be differently measured according to DQ loading cap.

11.2 M393T6553GZ3 / M393T6553GZA : 512MB(64Mx8 *9) Module

- considering Register and PLL current value

(TA=0°C, V_{DD}= 1.9V)

Symbol	F7(800@CL=6)	E6(667@CL=5)	D5(533@CL=4)	CC(400@CL=3)	Units	Notes
IDD0	1355	1175	1085	950	mA	
IDD1	1495	1360	1225	1135	mA	
IDD2P	552	512	472	432	mA	
IDD2Q	845	775	660	590	mA	
IDD2N	840	780	675	615	mA	
IDD3P-F	820	740	660	580	mA	
IDD3P-S	658	578	498	418	mA	
IDD3N	1080	965	850	780	mA	
IDD4W	1510	1350	1145	1030	mA	
IDD4R	1850	1680	1375	1205	mA	
IDD5B	1660	1495	1375	1210	mA	
IDD6*	72	72	72	72	mA	
IDD7	2580	2155	2045	1935	mA	

* IDD6 = DRAM current + standby current of PLL and Register

** Module IDD was calculated on the basis of component IDD and can be differently measured according to DQ loading cap.

11.3 M393T2953GZ3 / M393T2953GZA : 1GB(64Mx8 *18) Module

(TA=0°C, V_{DD}= 1.9V)

Symbol	F7(800@CL=6)	E6(667@CL=5)	D5(533@CL=4)	CC(400@CL=3)	Units	Notes
IDD0	1125	1035	990	945	mA	
IDD1	1215	1170	1080	1080	mA	
IDD2P	144	144	144	144	mA	
IDD2Q	630	630	540	540	mA	
IDD2N	720	720	630	630	mA	
IDD3P-F	540	540	540	540	mA	
IDD3P-S	216	216	216	216	mA	
IDD3N	900	855	765	765	mA	
IDD4W	1350	1260	1080	1035	mA	
IDD4R	1620	1530	1260	1170	mA	
IDD5B	1350	1305	1260	1215	mA	
IDD6*	144	144	144	144	mA	
IDD7	2250	1935	1890	1890	mA	

* Module IDD was calculated on the basis of component IDD and can be differently measured according to DQ loading cap.

11.4 M393T2953GZ3 / M393T2953GZA : 1GB(64Mx8 *18) Module

- considering Register and PLL current value

(TA=0°C, V_{DD}= 1.9V)

Symbol	F7(800@CL=6)	E6(667@CL=5)	D5(533@CL=4)	CC(400@CL=3)	Units	Notes
IDD0	1815	1625	1480	1335	mA	
IDD1	1985	1830	1630	1520	mA	
IDD2P	784	724	664	604	mA	
IDD2Q	1340	1250	1070	980	mA	
IDD2N	1290	1220	1060	990	mA	
IDD3P-F	1270	1170	1070	970	mA	
IDD3P-S	946	846	746	646	mA	
IDD3N	1460	1345	1185	1115	mA	
IDD4W	2000	1820	1550	1415	mA	
IDD4R	2410	2210	1830	1630	mA	
IDD5B	2180	1985	1790	1595	mA	
IDD6*	144	144	144	144	mA	
IDD7	3280	2805	2600	2440	mA	

* IDD6 = DRAM current + standby current of PLL and Register

** Module IDD was calculated on the basis of component IDD and can be differently measured according to DQ loading cap.

11.5 M393T2950GZ3 / M393T2950GZA : 1GB(128Mx4 *18) Module

(TA=0°C, V_{DD}= 1.9V)

Symbol	F7(800@CL=6)	E6(667@CL=5)	D5(533@CL=4)	CC(400@CL=3)	Units	Notes
IDD0	1440	1350	1350	1350	mA	
IDD1	1620	1530	1530	1530	mA	
IDD2P	144	144	144	144	mA	
IDD2Q	630	630	540	540	mA	
IDD2N	720	720	630	630	mA	
IDD3P-F	540	540	540	540	mA	
IDD3P-S	216	216	216	216	mA	
IDD3N	990	990	900	900	mA	
IDD4W	2070	1800	1350	1350	mA	
IDD4R	2250	1980	1530	1530	mA	
IDD5B	2070	1980	1890	1890	mA	
IDD6*	144	144	144	144	mA	
IDD7	3780	3150	3150	3150	mA	

* Module IDD was calculated on the basis of component IDD and can be differently measured according to DQ loading cap.

11.6 M393T2950GZ3 / M393T2950GZA : 1GB(128Mx4 *18) Module

- considering Register and PLL current value

(TA=0°C, V_{DD}= 1.9V)

Symbol	F7(800@CL=6)	E6(667@CL=5)	D5(533@CL=4)	CC(400@CL=3)	Units	Notes
IDD0	2130	1940	1840	1740	mA	
IDD1	2390	2190	2080	1970	mA	
IDD2P	784	724	664	604	mA	
IDD2Q	1340	1250	1070	980	mA	
IDD2N	1290	1220	1060	990	mA	
IDD3P-F	1270	1170	1070	970	mA	
IDD3P-S	946	846	746	646	mA	
IDD3N	1550	1480	1320	1250	mA	
IDD4W	2720	2360	1820	1730	mA	
IDD4R	3040	2660	2100	1990	mA	
IDD5B	2900	2660	2420	2270	mA	
IDD6*	144	144	144	144	mA	
IDD7	4810	4020	3860	3700	mA	

* IDD6 = DRAM current + standby current of PLL and Register

** Module IDD was calculated on the basis of component IDD and can be differently measured according to DQ loading cap.

11.7 M393T5750GZ3 / M393T5750GZA : 2GB(128Mx4 *36) Module

(TA=0°C, V_{DD}= 1.9V)

Symbol	F7(800@CL=6)	E6(667@CL=5)	D5(533@CL=4)	CC(400@CL=3)	Units	Notes
IDD0	2160	2070	1980	1980	mA	
IDD1	2340	2250	2160	2160	mA	
IDD2P	288	288	288	288	mA	
IDD2Q	1260	1260	1080	1080	mA	
IDD2N	1440	1440	1260	1260	mA	
IDD3P-F	1080	1080	1080	1080	mA	
IDD3P-S	432	432	432	432	mA	
IDD3N	1710	1710	1530	1530	mA	
IDD4W	2790	2520	1980	1980	mA	
IDD4R	2970	2700	2160	2160	mA	
IDD5B	2790	2700	2520	2520	mA	
IDD6*	288	288	288	288	mA	
IDD7	4500	3870	3780	3780	mA	

* Module IDD was calculated on the basis of component IDD and can be differently measured according to DQ loading cap.

11.8 M393T5750GZ3 / M393T5750GZA : 2GB(128Mx4 *36) Module

- considering Register and PLL current value

(TA=0°C, V_{DD}= 1.9V)

Symbol	F7(800@CL=6)	E6(667@CL=5)	D5(533@CL=4)	CC(400@CL=3)	Units	Notes
IDD0	3180	2940	2700	2550	mA	
IDD1	3500	3250	3000	2840	mA	
IDD2P	1238	1148	1058	968	mA	
IDD2Q	2320	2180	1860	1720	mA	
IDD2N	2240	2140	1860	1760	mA	
IDD3P-F	2170	2020	1870	1720	mA	
IDD3P-S	1522	1372	1222	1072	mA	
IDD3N	2500	2400	2120	2020	mA	
IDD4W	3780	3370	2690	2550	mA	
IDD4R	4060	3640	2950	2800	mA	
IDD5B	4010	3700	3300	3080	mA	
IDD6*	288	288	288	288	mA	
IDD7	6210	5320	4970	4710	mA	

* IDD6 = DRAM current + standby current of PLL and Register

** Module IDD was calculated on the basis of component IDD and can be differently measured according to DQ loading cap.

12.0 Input/Output Capacitance

(V_{DD}=1.8V, V_{DDQ}=1.8V, TA=25°C)

Parameter	Symbol	Min	Max	Min	Max	Min	Max	Min	Max	Units
Part-Number		M393T6553GZ3 M393T6553GZA		M393T2953GZ3 M393T2953GZA		M393T2950GZ3 M393T2950GZA		M393T5750GZ3 M393T5750GZA		
Input capacitance, CK and \overline{CK}	CCK	-	11	-	11	-	11	-	11	pF
Input capacitance, CKE and \overline{CS}	CI1	-	12	-	12	-	12	-	12	
Input capacitance, Address, \overline{RAS} , \overline{CAS} , \overline{WE}	CI2	-	12	-	12	-	12	-	12	
Input/output capacitance, DQ, DM, DQS, \overline{DQS}	CIO	-	10	-	10	-	10	-	10	

* DM is internally loaded to match DQ and DQS identically.

13.0 Electrical Characteristics & AC Timing for DDR2-800/667/533/400

(0 °C ≤ T_{OPER} ≤ 95 °C; V_{DDQ} = 1.8V ± 0.1V; V_{DD} = 1.8V ± 0.1V)

13.1 Refresh Parameters by Device Density

Parameter	Symbol	256Mb	512Mb	1Gb	2Gb	4Gb	Units	
Refresh to active/Refresh command time	tRFC	75	105	127.5	195	327.5	ns	
Average periodic refresh interval	tREFI	0 °C ≤ T _{CASE} ≤ 85°C	7.8	7.8	7.8	7.8	7.8	μs
		85 °C < T _{CASE} ≤ 95°C	3.9	3.9	3.9	3.9	3.9	μs

13.2 Speed Bins and CL, tRCD, tRP, tRC and tRAS for Corresponding Bin

Speed	DDR2-800(F7)		DDR2-667(E6)		DDR2-533(D5)		DDR2-400(CC)		Units
Bin(CL - tRCD - tRP)	6 - 6 - 6		5 - 5 - 5		4 - 4 - 4		3 - 3 - 3		
Parameter	min	max	min	max	min	max	min	max	
tCK, CL=3	-	-	5	8	5	8	5	8	ns
tCK, CL=4	3.75	8	3.75	8	3.75	8	5	8	ns
tCK, CL=5	3	8	3	8	3.75	8	-	-	ns
tCK, CL=6	2.5	8	-	-	-	-	-	-	ns
tRCD	15	-	15	-	15	-	15	-	ns
tRP	15	-	15	-	15	-	15	-	ns
tRC	60	-	60	-	60	-	55	-	ns
tRAS	45	70000	45	70000	45	70000	40	70000	ns

13.3 Timing parameters by speed grade (DDR2-800 and DDR2-667)

(Refer to notes for informations related to this table at the component datasheet)

Parameter	Symbol	DDR2-800		DDR2-667		Units	Notes
		min	max	min	max		
DQ output access time from CK/ $\overline{\text{CK}}$	tAC	-400	400	-450	450	ps	40
DQS output access time from CK/ $\overline{\text{CK}}$	tDQSCK	-350	350	-400	400	ps	40
Average clock HIGH pulse width	tCH(avg)	0.48	0.52	0.48	0.52	tCK(avg)	35,36
Average clock LOW pulse width	tCL(avg)	0.48	0.52	0.48	0.52	tCK(avg)	35,36
CK half pulse period	tHP	Min(tCL(abs), tCH(abs))	x	Min(tCL(abs), tCH(abs))	x	ps	37
Average clock period	tCK(avg)	2500	8000	3000	8000	ps	35,36
DQ and DM input hold time	tDH(base)	125	x	175	x	ps	6,7,8,21,28,31
DQ and DM input setup time	tDS(base)	50	x	100	x	ps	6,7,8,20,28,31
Control & Address input pulse width for each input	tIPW	0.6	x	0.6	x	tCK(avg)	
DQ and DM input pulse width for each input	tDIPW	0.35	x	0.35	x	tCK(avg)	
Data-out high-impedance time from CK/ $\overline{\text{CK}}$	tHZ	x	tAC(max)	x	tAC(max)	ps	18,40
DQS/ $\overline{\text{DQS}}$ low-impedance time from CK/ $\overline{\text{CK}}$	tLZ(DQS)	tAC(min)	tAC(max)	tAC(min)	tAC(max)	ps	18,40
DQ low-impedance time from CK/ $\overline{\text{CK}}$	tLZ(DQ)	2* tAC(min)	tAC(max)	2* tAC(min)	tAC(max)	ps	18,40
DQS-DQ skew for DQS and associated DQ signals	tDQSQ	x	200	x	240	ps	13
DQ hold skew factor	tQHS	x	300	x	340	ps	38
DQ/DQS output hold time from DQS	tQH	tHP - tQHS	x	tHP - tQHS	x	ps	39
DQS latching rising transitions to associated clock edges	tDQSS	- 0.25	0.25	-0.25	0.25	tCK(avg)	30
DQS input HIGH pulse width	tDQSH	0.35	x	0.35	x	tCK(avg)	
DQS input LOW pulse width	tDQSL	0.35	x	0.35	x	tCK(avg)	
DQS falling edge to CK setup time	tDSS	0.2	x	0.2	x	tCK(avg)	30
DQS falling edge hold time from CK	tDSH	0.2	x	0.2	x	tCK(avg)	30
Mode register set command cycle time	tMRD	2	x	2	x	nCK	
MRS command to ODT update delay	tMOD	0	12	0	12	ns	32
Write postamble	tWPST	0.4	0.6	0.4	0.6	tCK(avg)	10
Write preamble	tWPRE	0.35	x	0.35	x	tCK(avg)	
Address and control input hold time	tIH(base)	250	x	275	x	ps	5,7,9,23,29
Address and control input setup time	tIS(base)	175	x	200	x	ps	5,7,9,22,29
Read preamble	tRPRE	0.9	1.1	0.9	1.1	tCK(avg)	19,41
Read postamble	tRPST	0.4	0.6	0.4	0.6	tCK(avg)	19,42
Activate to activate command period for 1KB page size products	tRRD	7.5	x	7.5	x	ns	4,32
Activate to activate command period for 2KB page size products	tRRD	10	x	10	x	ns	4,32

Parameter	Symbol	DDR2-800		DDR2-667		Units	Notes
		min	max	min	max		
Four Activate Window for 1KB page size products	tFAW	35	x	37.5	x	ns	32
Four Activate Window for 2KB page size products	tFAW	45	x	50	x	ns	32
CAS to CAS command delay	tCCD	2	x	2	x	nCK	
Write recovery time	tWR	15	x	15	x	ns	32
Auto precharge write recovery + precharge time	tDAL	WR + tnRP	x	WR + tnRP	x	nCK	33
Internal write to read command delay	tWTR	7.5	x	7.5	x	ns	24,32
Internal read to precharge command delay	tRTP	7.5	x	7.5	x	ns	3,32
Exit self refresh to a non-read command	tXSNR	tRFC + 10	x	tRFC + 10	x	ns	32
Exit self refresh to a read command	tXSRD	200	x	200	x	nCK	
Exit precharge power down to any command	tXP	2	x	2	x	nCK	
Exit active power down to read command	tXARD	2	x	2	x	nCK	1
Exit active power down to read command (slow exit, lower power)	tXARDS	8 - AL	x	7 - AL	x	nCK	1,2
CKE minimum pulse width (HIGH and LOW pulse width)	tCKE	3	x	3	x	nCK	27
ODT turn-on delay	tAOND	2	2	2	2	nCK	16
ODT turn-on	tAON	tAC(min)	tAC(max)+0.7	tAC(min)	tAC(max)+0.7	ns	6,16,40
ODT turn-on (Power-Down mode)	tAONPD	tAC(min)+2	2*tCK(avg)+tAC(max)+1	tAC(min)+2	2*tCK(avg)+tAC(max)+1	ns	
ODT turn-off delay	tAOFD	2.5	2.5	2.5	2.5	nCK	17,45
ODT turn-off	tAOF	tAC(min)	tAC(max)+0.6	tAC(min)	tAC(max)+0.6	ns	17,43,45
ODT turn-off (Power-Down mode)	tAOFPD	tAC(min)+2	2.5*tCK(avg)+tAC(max)+1	tAC(min)+2	2.5*tCK(avg)+tAC(max)+1	ns	
ODT to power down entry latency	tANPD	3	x	3	x	nCK	
ODT power down exit latency	tAXPD	8	x	8	x	nCK	
OCD drive mode output delay	tOIT	0	12	0	12	ns	32
Minimum time clocks remains ON after CKE asynchronously drops LOW	tDelay	tIS+tCK(avg)+tIH	x	tIS+tCK(avg)+tIH	x	ns	15

13.4 Timing parameters by speed grade (DDR2-533 and DDR2-400)

(Refer to notes for informations related to this table at the component datasheet)

Parameter	Symbol	DDR2-533		DDR2-400		Units	Notes
		min	max	min	max		
DQ output access time from CK/ $\overline{\text{CK}}$	tAC	-500	500	-600	600	ps	
DQS output access time from CK/ $\overline{\text{CK}}$	tDQSCK	-450	450	-500	500	ps	
CK HIGH pulse width	tCH	0.45	0.55	0.45	0.55	tCK	
CK LOW pulse width	tCL	0.45	0.55	0.45	0.55	tCK	
CK half pulse period	tHP	Min(tCL, tCH)	x	Min(tCL, tCH)	x	ps	11,12
Clock cycle time, CL=x	tCK	3750	8000	5000	8000	ps	15
DQ and DM input hold time (differential strobe)	tDH(base)	225	x	275	x	ps	6,7,8,21,28
DQ and DM input setup time (differential strobe)	tDS(base)	100	x	150	x	ps	6,7,8,20,28
DQ and DM input hold time (single-ended strobe)	tDH1(base)	-25	x	25	x	ps	6,7,8,26
DQ and DM input setup time (single-ended strobe)	tDS1(base)	-25	x	25	x	ps	6,7,8,25
Control & Address input pulse width for each input	tIPW	0.6	x	0.6	x	tCK	
DQ and DM input pulse width for each input	tDIPW	0.35	x	0.35	x	tCK	
Data-out high-impedance time from CK/ $\overline{\text{CK}}$	tHZ	x	tAC(max)	x14	tAC(max)	ps	18
DQS($\overline{\text{DQS}}$) low-impedance time from CK/ $\overline{\text{CK}}$	tLZ(DQS)	tAC(min)	tAC(max)	tAC(min)	tAC(max)	ps	18
DQ low-impedance time from CK/ $\overline{\text{CK}}$	tLZ(DQ)	2* tAC(min)	tAC(max)	2* tAC(min)	tAC(max)	ps	18
DQS-DQ skew for DQS and associated DQ signals	tDQSQ	x	300	x	350	ps	13
DQ hold skew factor	tQHS	x	400	x	450	ps	12
DQ/DQS output hold time from DQS	tQH	tHP - tQHS	x	tHP - tQHS	x	ps	
DQS latching rising transitions to associated clock edges	tDQSS	-0.25	0.25	-0.25	0.25	tCK	
DQS input HIGH pulse width	tDQSH	0.35	x	0.35	x	tCK	
DQS input LOW pulse width	tDQSL	0.35	x	0.35	x	tCK	
DQS falling edge to CK setup time	tDSS	0.2	x	0.2	x	tCK	
DQS falling edge hold time from CK	tDSH	0.2	x	0.2	x	tCK	
Mode register set command cycle time	tMRD	2	x	2	x	tCK	
MRS command to ODT update delay	tMOD	0	12	0	12	ns	
Write postamble	tWPST	0.4	0.6	0.4	0.6	tCK	10
Write preamble	tWPRE	0.35	x	0.35	x	tCK	
Address and control input hold time	tIH(base)	375	x	475	x	ps	5,7,9,23
Address and control input setup time	tIS(base)	250	x	350	x	ps	5,7,9,22
Read preamble	tRPRE	0.9	1.1	0.9	1.1	tCK	19
Read postamble	tRPST	0.4	0.6	0.4	0.6	tCK	19
Active to active command period for 1KB page size products	tRRD	7.5	x	7.5	x	ns	4
Active to active command period for 2KB page size products	tRRD	10	x	10	x	ns	4

Parameter	Symbol	DDR2-533		DDR2-400		Units	Notes
		min	max	min	max		
Four Activate Window for 1KB page size products	tFAW	37.5	x	37.5	x	ns	
Four Activate Window for 2KB page size products	tFAW	50	x	50	x	ns	
CAS to CAS command delay	tCCD	2	x	2	x	tCK	
Write recovery time	tWR	15	x	15	x	ns	
Auto precharge write recovery + precharge time	tDAL	WR+tRP	x	WR+tRP	x	tCK	14
Internal write to read command delay	tWTR	7.5	x	10	x	ns	24
Internal read to precharge command delay	tRTP	7.5	x	7.5	x	ns	3
Exit self refresh to a non-read command	tXSNR	tRFC + 10	x	tRFC + 10	x	ns	
Exit self refresh to a read command	tXSRD	200	x	200	x	tCK	
Exit precharge power down to any non-read command	tXP	2	x	2	x	tCK	
Exit active power down to read command	tXARD	2	x	2	x	tCK	1
Exit active power down to read command (slow exit, lower power)	tXARDS	6 - AL	x	6 - AL	x	tCK	1,2
CKE minimum pulse width (HIGH and LOW pulse width)	tCKE	3	x	3	x	tCK	27
ODT turn-on delay	tAOND	2	2	2	2	tCK	16
ODT turn-on	tAON	tAC(min)	tAC(max)+1	tAC(min)	tAC(max)+1	ns	16
ODT turn-on (Power-Down mode)	tAONPD	tAC(min)+2	2tCK+ tAC(max)+1	tAC(min)+2	2tCK+ tAC(max)+1	ns	
ODT turn-off delay	tAOFD	2.5	2.5	2.5	2.5	tCK	17,44
ODT turn-off	tAOF	tAC(min)	tAC(max) + 0.6	tAC(min)	tAC(max) + 0.6	ns	17,44
ODT turn-off (Power-Down mode)	tAOFPD	tAC(min)+2	2.5tCK+ tAC(max)+1	tAC(min)+2	2.5tCK+ tAC(max)+1	ns	
ODT to power down entry latency	tANPD	3	x	3	x	tCK	
ODT power down exit latency	tAXPD	8	x	8	x	tCK	
OCD drive mode output delay	tOIT	0	12	0	12	ns	32
Minimum time clocks remains ON after CKE asynchronously drops LOW	tDelay	tIS+tCK+tIH	x	tIS+tCK+tIH	x	ns	15

14.0 Physical Dimensions

14.1 64Mbx8 based 64Mx72 Module (1 Rank)

- M393T6553GZ3 / M393T6553GZA

Units : Millimeters

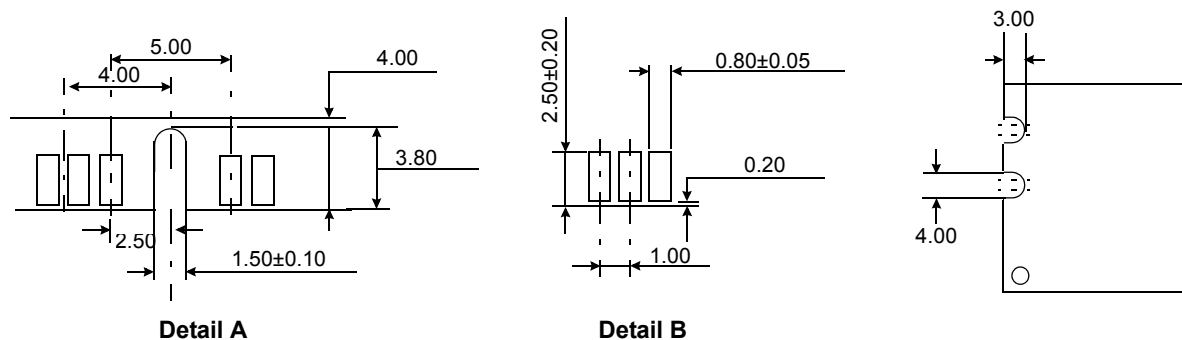
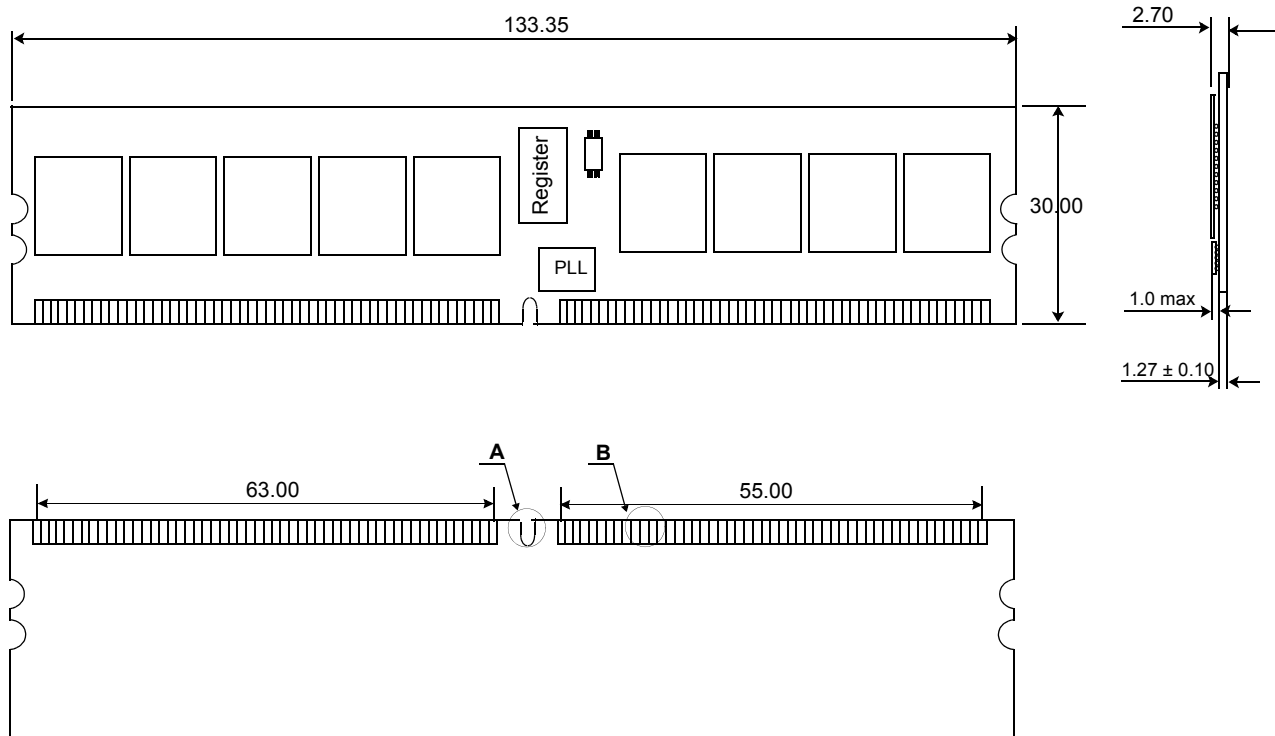

The used device is 64M x8 DDR2 SDRAM, FBGA.
DDR2 SDRAM Part NO : K4T51083QG

14.2 64Mbx8/128Mbx4 based 128Mx72 Module (2/1 Ranks)

- M393T2953GZ3 / M393T2953GZA / M393T2950GZ3 / M393T2950GZA

Units : Millimeters

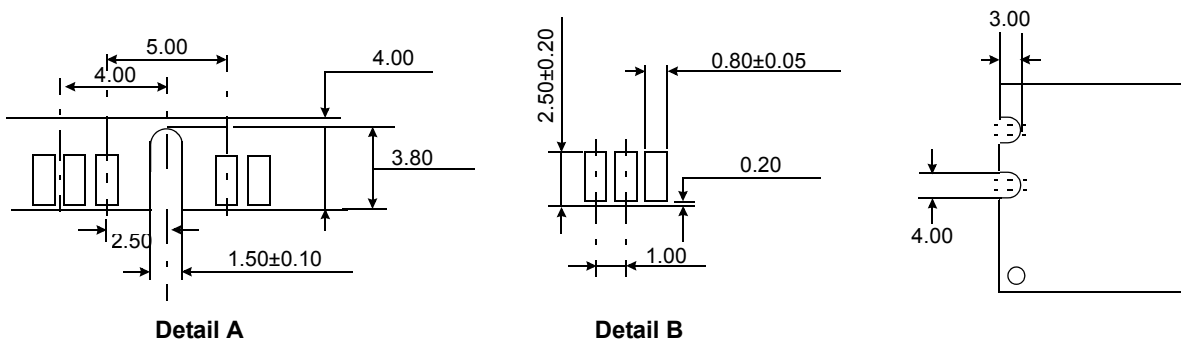
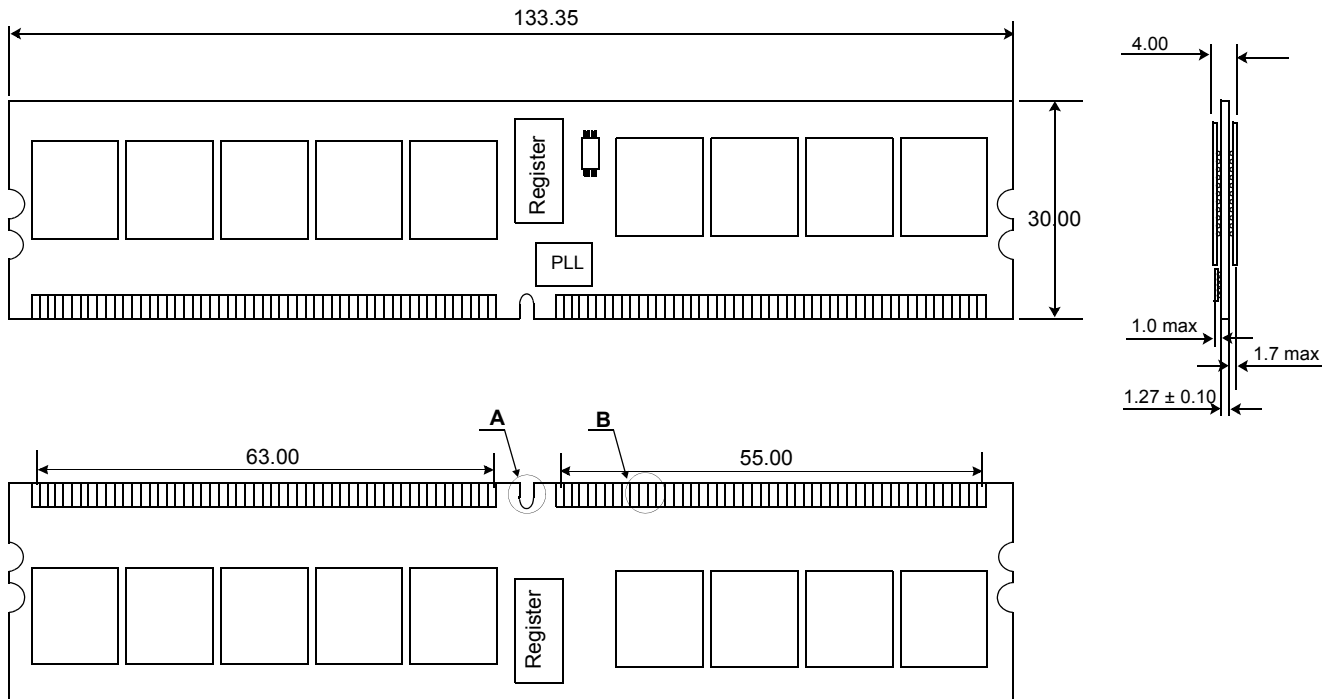

The used device is 64M x8 / 128M x4 DDR2 SDRAM, FBGA.
DDR2 SDRAM Part NO : K4T51083QG / K4T51043QG

14.3 128Mbx4 based 256Mx72 Module (2 Ranks)

- M393T5750GZ3/M393T5750GZA

Units : Millimeters

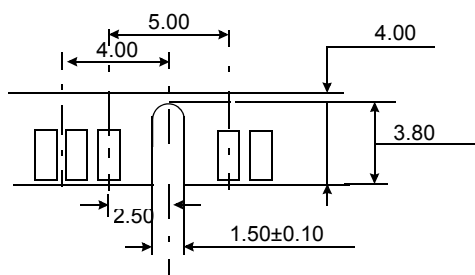
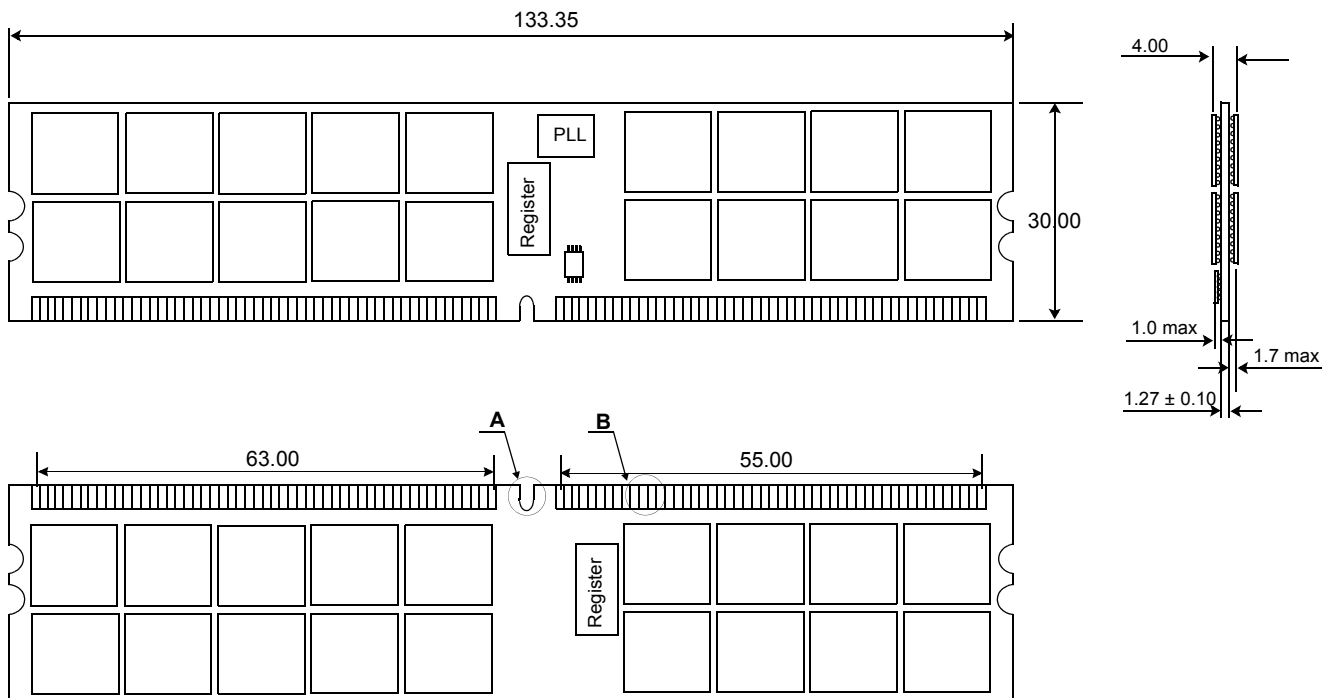

Detail A

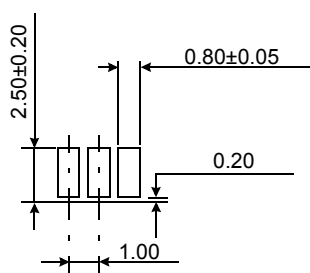

Detail B

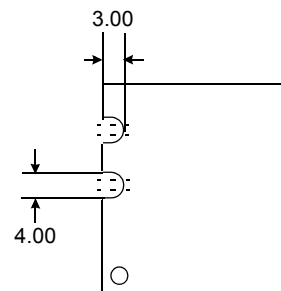

The used device is 128M x4 DDR2 SDRAM, FBGA.
DDR2 SDRAM Part NO : K4T51043QG

15.0 240 Pin DDR2 Registered DIMM Clock Topology

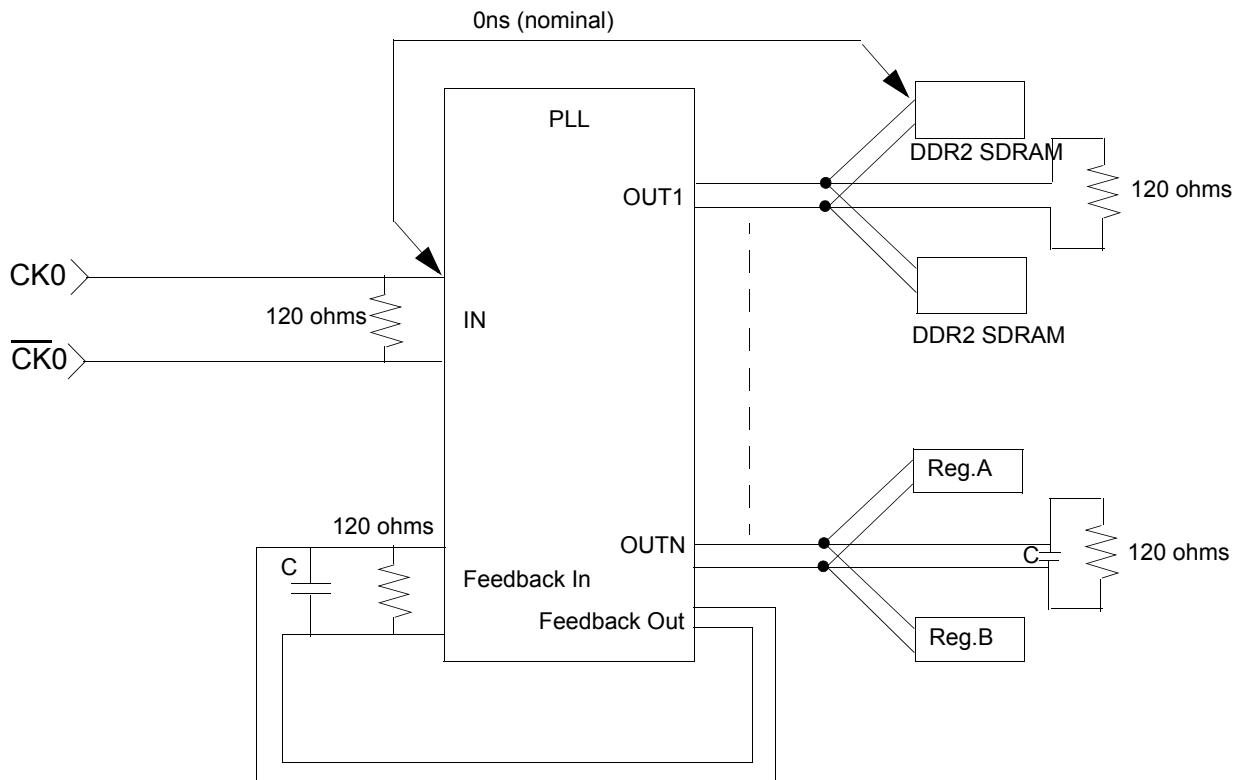

Note:

- 1. The clock delay from the input of the PLL clock to the input of any DDR2 SDRAM or register will be set to 0ns (nominal).
- 2. Input, output, and feedback clock lines are terminated from line to line as shown, and not from line to ground.
- 3. Only one PLL output is shown per output type. Any additional PLL outputs will be wired in a similar manner.
- 4. Termination resistors for the PLL feedback path clocks are located as close to the input pin of the PLL as possible.