



AXIOM
MICRODEVICES INC.



AX508

GSM/GPRS Quad Band Power Amplifier

PRODUCT DESCRIPTION

The AX508 device integrates a full quad band GSM/GPRS power amplifier function on a single Integrated Circuit (IC) using advanced 0.13 μm silicon CMOS process technology. Key benefits of the AX508 include improved performance, relative to its AX502 product, equating to a longer talk time. With the AX508, Axiom Microdevices also offers a smaller footprint by housing the PA in an ultra-low profile micro lead frame package measuring 5x3.5x0.9 millimeters (mm).

Axiom Microdevices' CMOS power amplifiers were developed using the company's patented Distributed Active Transformer (DAT) technology, which has made it possible to use 0.13-micrometer silicon CMOS process technology to integrate all of the functions between transmitter output and transmit/receive switch. Leveraging DAT technology, Axiom Microdevices realizes power gain stages, small signal control circuitry and 50-ohm input and output matching circuitry on a single die, enables direct connection to the transceiver output and the transmit/receive switch input without the use of the external matching components, helping designers to achieve what was previously only viable with devices manufactured in proprietary gallium arsenide (GaAs) process technology and assembled in complex multi-chip module packaging.

APPLICATIONS

- ▶ GSM/GPRS Dual, Triple, Quad-Band Mobile Terminal and Data Applications

FEATURES

- ▶ GSM/GPRS Class 12 operation
- ▶ Power supply range of 2.9-5.5
- ▶ Temperature -20°C to +85 °C
- ▶ RF input range: -2 to 8dBm
- ▶ Fully integrated on chip 50-ohm matching circuits
- ▶ Fully integrated closed-loop power control
- ▶ Dual, Voltage and Load Current, Sense Architecture for Robust Power Control
- ▶ Current Limiting Circuitry for Load Mismatch (VSWR) Events
- ▶ <100 dB/V Power Control Slope
- ▶ Improved Power Added Efficiency
- ▶ Extended Range for Low Power Mode Operation

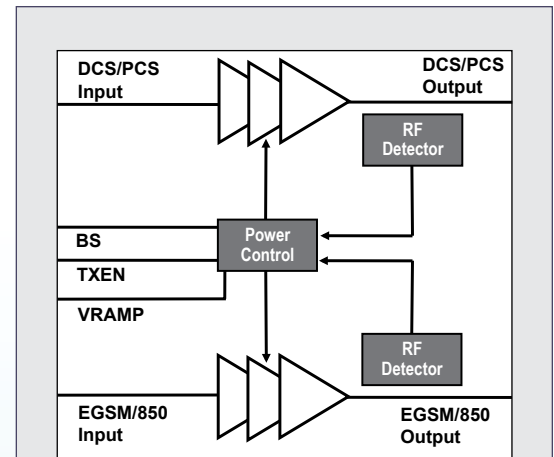

TECHNOLOGY

- ▶ 0.13 μm CMOS Technology
- ▶ Patented Distributed Active Transformer (DAT) Technology
- ▶ Low Profile MicroLeadFrame Package (5x3.5x0.9 mm)



powering wireless innovation

www.axiom-micro.com