

**DATA SHEET**

# SKY12338-337LF: 0.35-4.0 GHz Two-Bit Digital Attenuator

**Applications**

- Cellular infrastructure
- Wireless receivers

**Features**

- Positive voltage operation: 2.65 to 5 V per bit
- Broadband operation: 0.35 to 4.0 GHz
- Attenuation: 18 dB with 6 dB LSB
- Low insertion loss: 0.75 dB @ 2 GHz
- Absorptive in 50 Ω systems
- Small, QFN (12-pin, 3 x 3 mm) package (MSL1, 260 °C per JEDEC J-STD-020)

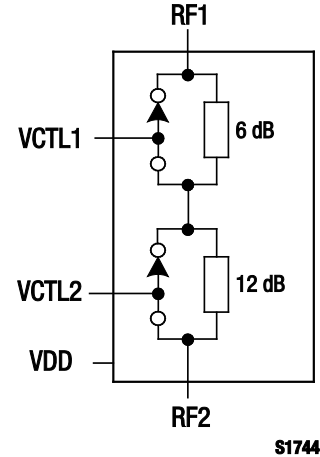

**Figure 1. SKY12338-337LF Block Diagram**



Skyworks Green™ products are RoHS (Restriction of Hazardous Substances)-compliant, conform to the EIA/EICTA/JEITA Joint Industry Guide (JIG) Level A guidelines, are halogen free according to IEC-61249-2-21, and contain <1,000 ppm antimony trioxide in polymeric materials.

**Description**

The SKY12338-337LF is a GaAs pHEMT two-bit digital attenuator I/C. The device is provided in a 3 x 3 mm, 12-pin Quad Flat No-Lead (QFN) package.

The SKY12338-337LF is particularly suited for low-cost commercial applications for which high attenuation accuracy, low insertion loss, and low intermodulation products are required.

A functional block diagram is shown in Figure 1. The pin configuration and package are shown in Figure 2. Signal pin assignments and functional pin descriptions are provided in Table 1.

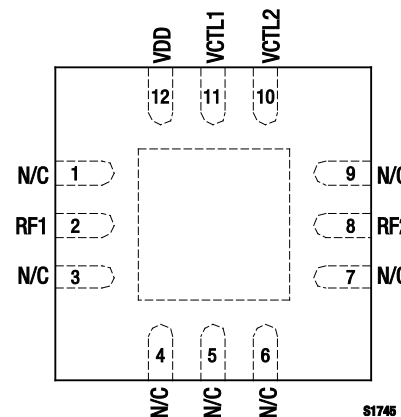

**Figure 2. SKY12338-337LF Pinout – 12-Pin QFN (Top View)**

**Table 1. SKY12338-337LF Signal Descriptions**

Pin #	Name	Description	Pin #	Name	Description
1	N/C	No connection required. May be connected to ground with no change in performance.	7	N/C	No connection.
2	RF1	RF port. Must be DC blocked.	8	RF2	RF port. Must be DC blocked.
3	N/C	No connection required. May be connected to ground with no change in performance.	9	N/C	No connection required. May be connected to ground with no change in performance.
4	N/C	No connection required. May be connected to ground with no change in performance.	10	VCTL2	DC control voltage. Controls 12 dB attenuation state. Refer to Table 4.
5	N/C	No connection required. May be connected to ground with no change in performance.	11	VCTL1	DC control voltage. Controls 6 dB attenuation state. Refer to Table 4.
6	N/C	No connection required. May be connected to ground with no change in performance.	12	VDD	DC power supply.

**Note:** Exposed pad must be grounded.

**Table 2. SKY12338-337LF Absolute Maximum Ratings**

Parameter	Symbol	Minimum	Typical	Maximum	Units
Supply voltage	V <sub>DD</sub>			5.5	V
Control voltage	VCTL1, VCTL2			V <sub>DD</sub> + 0.1	V
RF input power @ 3 V	P <sub>IN</sub>			+27	dBm
Operating temperature	T <sub>OP</sub>	-40		+85	°C
Storage temperature	T <sub>STG</sub>	-65		+150	°C

**Note:** Exposure to maximum rating conditions for extended periods may reduce device reliability. There is no damage to device with only one parameter set at the limit and all other parameters set at or below their nominal value. Exceeding any of the limits listed here may result in permanent damage to the device.

**CAUTION:** Although this device is designed to be as robust as possible, Electrostatic Discharge (ESD) can damage this device. This device must be protected at all times from ESD. Static charges may easily produce potentials of several kilovolts on the human body or equipment, which can discharge without detection. Industry-standard ESD precautions should be used at all times.

## Functional Description

This attenuator has a least significant bit (LSB) of 6 dB and a most significant bit (MSB) of 12 dB for a total of 18 dB available attenuation. Pins 10 and 11 (VCTL2 and VCTL1) control the state of the 6 dB and 12 dB attenuation bits, respectively. For each bit, a logic low enables the attenuation state while a logic high enables a low insertion loss state.

## Electrical and Mechanical Specifications

The absolute maximum ratings of the SKY12338-337LF are provided in Table 2. Electrical specifications are provided in Table 3.

The state of the SKY12338-337LF is determined by the logic provided in Table 4. The VCTL1 and VCTL2 signals control the 6 dB and 12 dB attenuation bits, respectively. For each bit, a logic low enables the attenuation state, while a logic high enables the insertion loss state.

Typical performance characteristics are illustrated in Figure 3 to Figure 6.

**Table 3. SKY12338-337LF Electrical Specifications (Note 1)**

**(V<sub>DD</sub> = 3 V, V<sub>CTL</sub> = 0 to 3 V, T<sub>OP</sub> = +25 °C, P<sub>IN</sub> = 0 dBm, Characteristic Impedance [Z<sub>0</sub>] = 50 Ω, C1 & C2 = 1000 pF, Unless Otherwise Noted)**

Parameter	Symbol	Test Condition	Min	Typical	Max	Units
Insertion loss	IL	350 to 500 MHz		0.55	0.80	dB
		500 MHz to 2 GHz		0.75	1.00	dB
		2 GHz to 3 GHz		1.00	1.20	dB
		3 GHz to 4 GHz		1.30	1.50	dB
Attenuation accuracy	Att	350 to 500 MHz	±(0.5 + 2% of attenuation setting)			dB
		500 MHz to 2 GHz	±(0.2 + 3% of attenuation setting)			dB
		2 GHz to 3 GHz	±(0.3 + 3% of attenuation setting)			dB
		3 GHz to 4 GHz	±(0.4 + 3% of attenuation setting)			dB
Return loss	IS11l	350 to 500 MHz	10	12		dB
		500 MHz to 2 GHz	13	15		dB
		2 GHz to 4 GHz	12	15		dB
Switching characteristics: Rise/fall time		50% V <sub>CTL</sub> to 90% RF or 10 to 90% RF		100		ns
			On/off time		100	
Attenuation phase settling (Note 2)		Phase change from 500 ns to 5 ms	-2		+2	deg
Attenuation settling amplitude	AT <sub>SET</sub>	Amplitude change from 500 ns to 5 ms			0.25	dB
1 dB Input Compression Point	IP1dB	V <sub>CTL</sub> = 2.65 V, 350 to 500 MHz, insertion state		+30		dBm
		V <sub>CTL</sub> = 3 V, 500 MHz to 4 GHz, insertion state		+27		dBm
0.1 dB Input Compression Point	IPO.1dB	V <sub>CTL</sub> = 2.65 V, 350 to 500 MHz, all states		+20		dBm
		V <sub>CTL</sub> = 3 V, 500 MHz to 4 GHz, all states		+20		dBm
3 <sup>rd</sup> Order Input Intercept Point	IIP3	V <sub>CTL</sub> = 2.65 V, 350 to 500 MHz, insertion state		+45		dBm
		V <sub>CTL</sub> = 2.65 V, 350 to 500 MHz, all states		+44		dBm
		V <sub>CTL</sub> = 3 V, 500 MHz to 4 GHz, insertion state		+45		dBm
		V <sub>CTL</sub> = 3 V, 500 MHz to 4 GHz, all states		+45		dBm
Supply voltage	V <sub>DD</sub>		2.65		5.00	V
Supply current	I <sub>DD</sub>			380	450	μA
Control voltage		V <sub>DD</sub>	2.65		5.00	V
		V <sub>CTL</sub> = low	0		0.2	V
		V <sub>CTL</sub> = high	V <sub>DD</sub> - 0.2		V <sub>DD</sub> + 0.1	V
Control current		V <sub>CTL</sub> = low		10		μA
		V <sub>CTL</sub> = high		250		μA

**Note 1:** Performance is guaranteed only under the conditions listed in this Table.

**Note 2:** Not measured. Performance guaranteed by design.

Table 4. SKY12338-337LF Truth Table

State	VDD	VCTL1	VCTL2
Insertion loss	high	high	high
6 dB	high	low	high
12 dB	high	high	low
18 dB	high	low	low

Note: high = +2.65 to 5 V  
 low = 0 to 0.2 V  
 Any state other than described in this Table places the attenuator into an undefined state.

**Typical Performance Characteristics**

(V<sub>DD</sub> = 3 V, V<sub>CTL</sub> = 0 to 3 V, T<sub>OP</sub> = +25 °C, P<sub>IN</sub> = 0 dBm, Characteristic Impedance [Z<sub>0</sub>] = 50 Ω, C1 & C2 = 1000 pF, Unless Otherwise Noted)

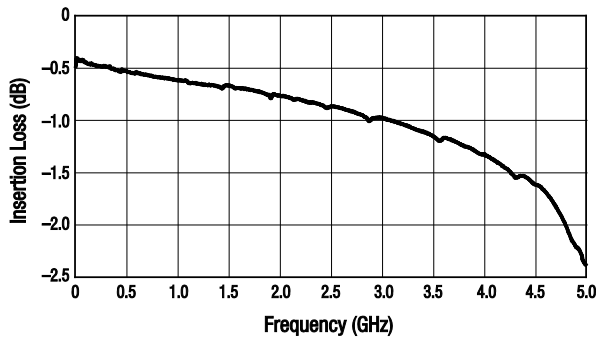

Figure 3. Insertion Loss vs Frequency

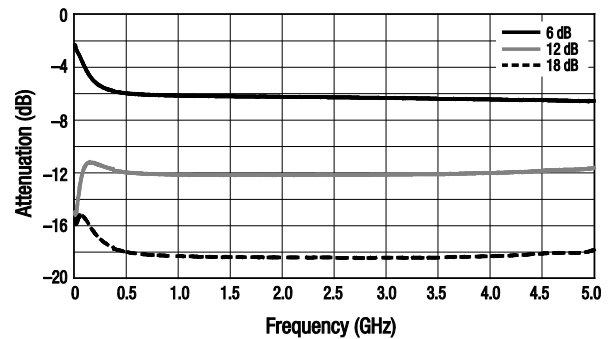

Figure 4. Attenuation vs Frequency (Normalized to Insertion Loss)

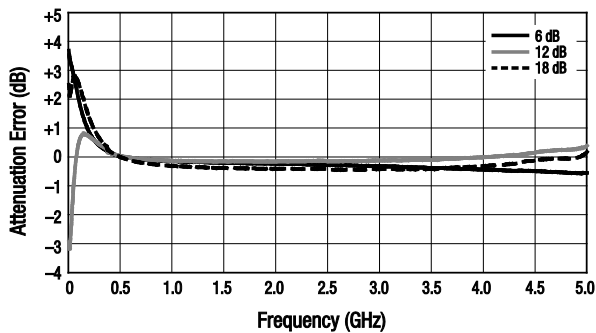

Figure 5. Attenuation Error vs Frequency (Normalized to Insertion Loss)

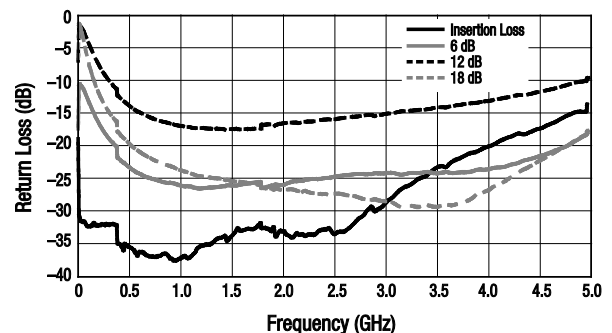

Figure 6. Return Loss vs Frequency

### Evaluation Board Description

The SKY12338-337LF Evaluation Board is used to test the performance of the SKY12338-337LF digital attenuator. An Evaluation Board schematic diagram is shown in Figure 7. Table 5 provides the Bill of Materials (BOM) list for Evaluation Board components. An assembly drawing for the Evaluation Board is shown in Figure 8.

### Package Dimensions

The PCB layout footprint for the SKY12338-337LF is shown in Figure 9. Typical case markings are noted in Figure 10. Package dimensions for the 12-pin QFN are shown in Figure 11, and tape and reel dimensions are provided in Figure 12.

### Package and Handling Information

Instructions on the shipping container label regarding exposure to moisture after the container seal is broken must be followed. Otherwise, problems related to moisture absorption may occur when the part is subjected to high temperature during solder assembly.

The SKY12338-337LF is rated to Moisture Sensitivity Level 1 (MSL1) at 260 °C. It can be used for lead or lead-free soldering. For additional information, refer to the Skyworks Application Note, *Solder Reflow Information*, document number 200164.

Care must be taken when attaching this product, whether it is done manually or in a production solder reflow environment. Production quantities of this product are shipped in a standard tape and reel format.

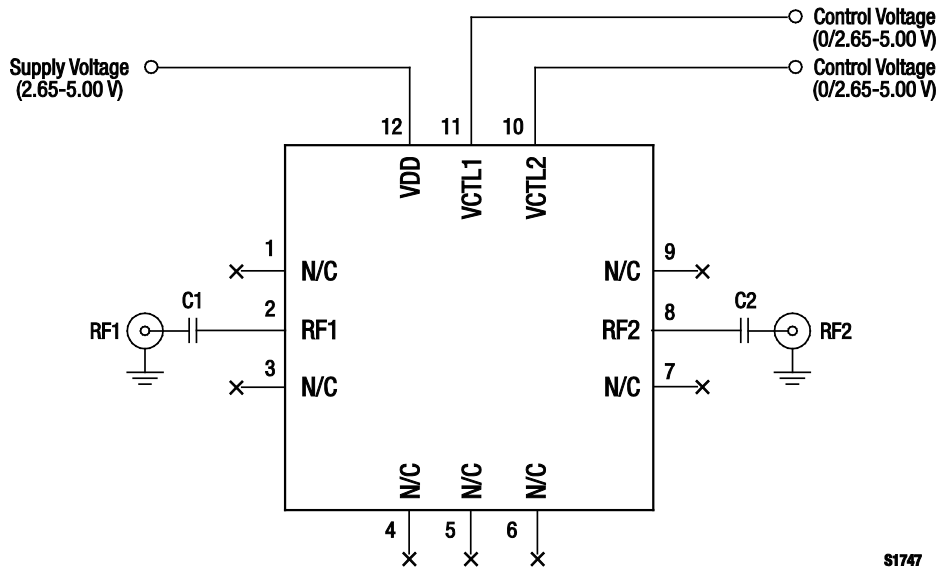
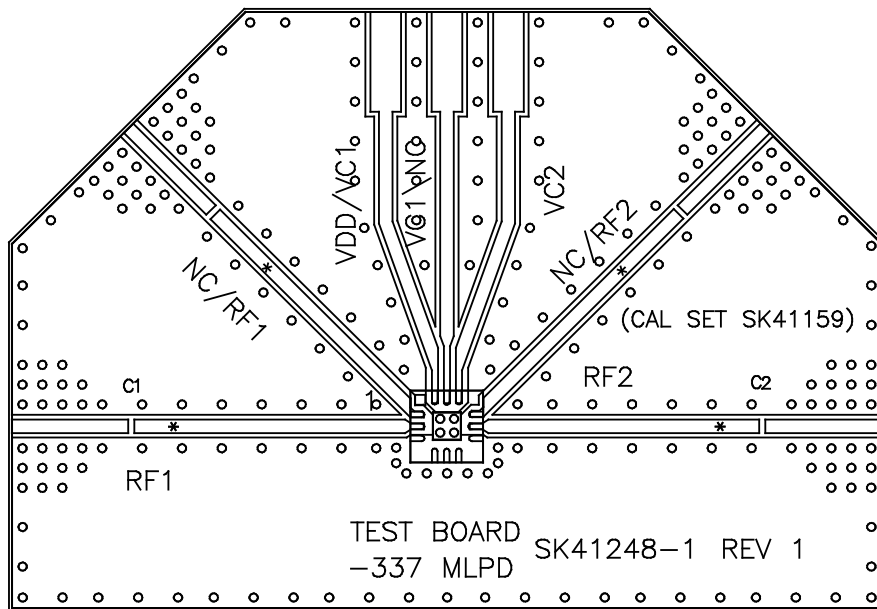

Figure 7. SKY12338-337LF Evaluation Board Schematic Diagram

Table 5. SKY12338-337LF Evaluation Board Bill of Materials

Component	Value	Size	Manufacturer/Part Series
C1, C2	1000 pF	0402	Murata GRM Series

Note: Blocking capacitors are required on both RF ports for proper functionality. Value of DC blocking capacitor determines lower frequency operation.



S1746

Figure 8. SKY12338-337LF Evaluation Board Assembly Diagram

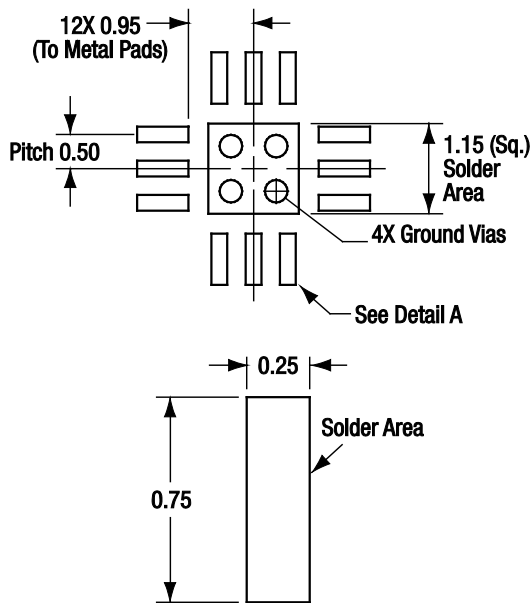

All measurements in millimeters

Detail A 12X  
Scale = 48X

S1855

Figure 9. SKY12338-337LF PCB Layout Footprint

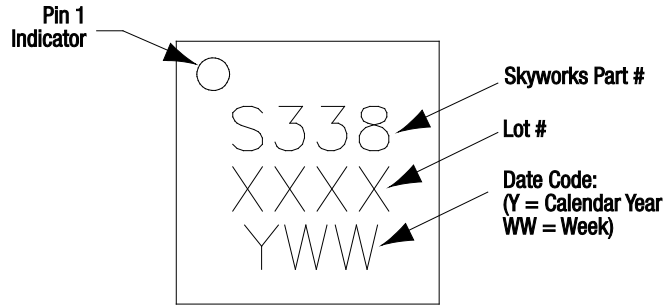
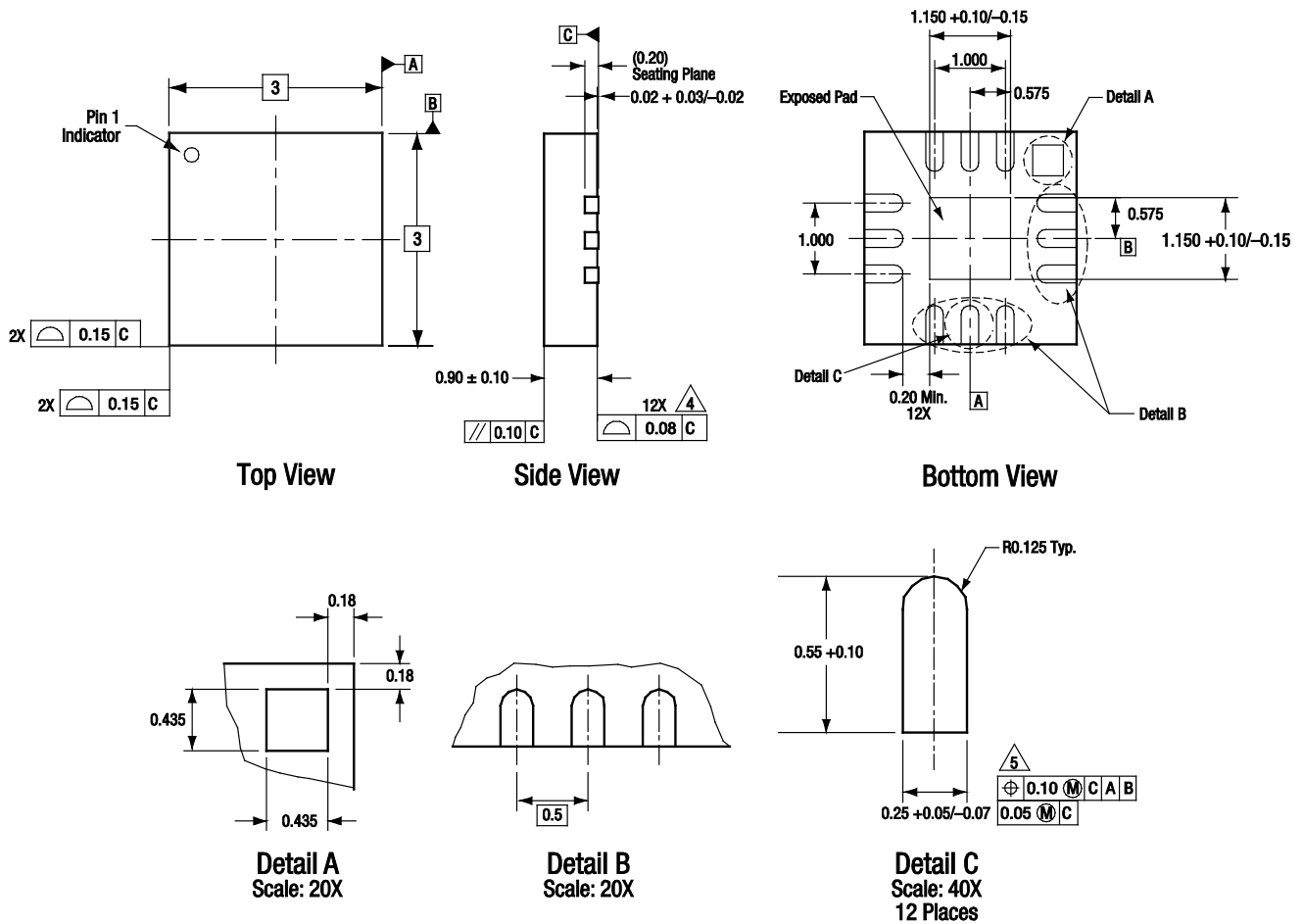

Figure 10. Typical Part Markings



All measurements are in millimeters.  
 Dimensioning and tolerancing according to ASME Y14.5M-1994.  
 Unilateral coplanarity applies to the exposed heat sink slug as well as the terminals.  
 Plating requirement per source control drawing (SCD) 2504.  
 Dimension applies to metallized terminal and is measured between 0.15 and 0.30 mm from the terminal tip. Do not measure at radius area.

S1866

Figure 11. SKY12338-337LF 12-Pin QFN Package Dimensions

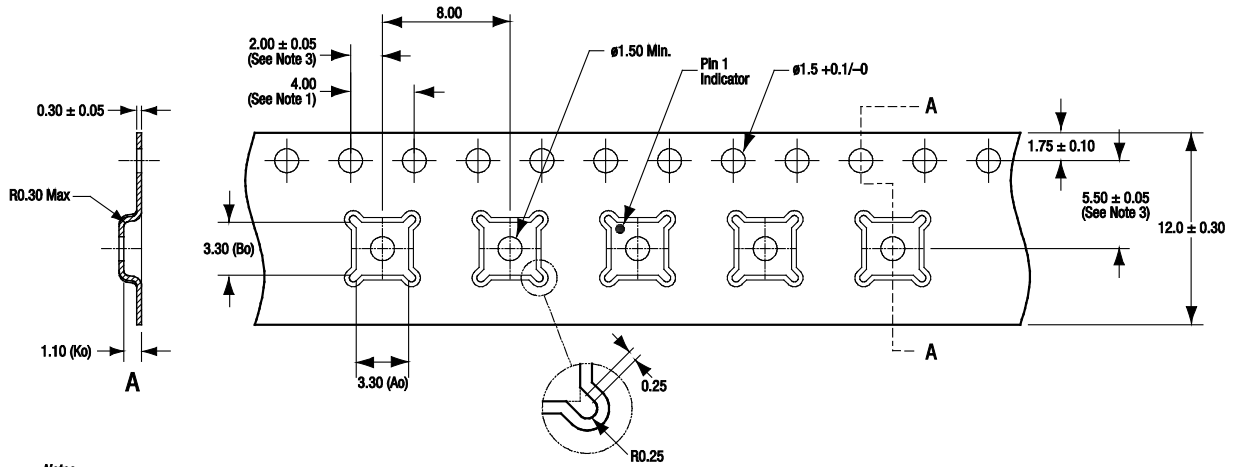

Notes:

1. Sprocket hole pitch cumulative tolerance:  $\pm 0.2$ .
2. Carrier tape: black conductive polystyrene.
3. Pocket position relative to sprocket hole, measure as true position of pocket, not pocket hole.
4. Cover tape material: transparent conductive PSA, 9.30 mm wide.
5. All dimensions are in millimeters.

S2892

Figure 12. SKY12338-337LF Tape and Reel Dimensions



**Ordering Information**

Model Name	Manufacturing Part Number	Evaluation Board Part Numbers
SKY12338-337LF Digital Attenuator	SKY12338-337LF	SKY12338-337LF-EVB

Copyright © 2009, 2011, 2012 Skyworks Solutions, Inc. All Rights Reserved.

Information in this document is provided in connection with Skyworks Solutions, Inc. ("Skyworks") products or services. These materials, including the information contained herein, are provided by Skyworks as a service to its customers and may be used for informational purposes only by the customer. Skyworks assumes no responsibility for errors or omissions in these materials or the information contained herein. Skyworks may change its documentation, products, services, specifications or product descriptions at any time, without notice. Skyworks makes no commitment to update the materials or information and shall have no responsibility whatsoever for conflicts, incompatibilities, or other difficulties arising from any future changes.

No license, whether express, implied, by estoppel or otherwise, is granted to any intellectual property rights by this document. Skyworks assumes no liability for any materials, products or information provided hereunder, including the sale, distribution, reproduction or use of Skyworks products, information or materials, except as may be provided in Skyworks Terms and Conditions of Sale.

THE MATERIALS, PRODUCTS AND INFORMATION ARE PROVIDED "AS IS" WITHOUT WARRANTY OF ANY KIND, WHETHER EXPRESS, IMPLIED, STATUTORY, OR OTHERWISE, INCLUDING FITNESS FOR A PARTICULAR PURPOSE OR USE, MERCHANTABILITY, PERFORMANCE, QUALITY OR NON-INFRINGEMENT OF ANY INTELLECTUAL PROPERTY RIGHT; ALL SUCH WARRANTIES ARE HEREBY EXPRESSLY DISCLAIMED. SKYWORKS DOES NOT WARRANT THE ACCURACY OR COMPLETENESS OF THE INFORMATION, TEXT, GRAPHICS OR OTHER ITEMS CONTAINED WITHIN THESE MATERIALS. SKYWORKS SHALL NOT BE LIABLE FOR ANY DAMAGES, INCLUDING BUT NOT LIMITED TO ANY SPECIAL, INDIRECT, INCIDENTAL, STATUTORY, OR CONSEQUENTIAL DAMAGES, INCLUDING WITHOUT LIMITATION, LOST REVENUES OR LOST PROFITS THAT MAY RESULT FROM THE USE OF THE MATERIALS OR INFORMATION, WHETHER OR NOT THE RECIPIENT OF MATERIALS HAS BEEN ADVISED OF THE POSSIBILITY OF SUCH DAMAGE.

Skyworks products are not intended for use in medical, lifesaving or life-sustaining applications, or other equipment in which the failure of the Skyworks products could lead to personal injury, death, physical or environmental damage. Skyworks customers using or selling Skyworks products for use in such applications do so at their own risk and agree to fully indemnify Skyworks for any damages resulting from such improper use or sale.

Customers are responsible for their products and applications using Skyworks products, which may deviate from published specifications as a result of design defects, errors, or operation of products outside of published parameters or design specifications. Customers should include design and operating safeguards to minimize these and other risks. Skyworks assumes no liability for applications assistance, customer product design, or damage to any equipment resulting from the use of Skyworks products outside of stated published specifications or parameters.

Skyworks, the Skyworks symbol, and "Breakthrough Simplicity" are trademarks or registered trademarks of Skyworks Solutions, Inc., in the United States and other countries. Third-party brands and names are for identification purposes only, and are the property of their respective owners. Additional information, including relevant terms and conditions, posted at [www.skyworksinc.com](http://www.skyworksinc.com), are incorporated by reference.