

SKY65206-13 WLAN 802.11b/g Intera™ Front-End Module

Applications

- Portable/mobile IEEE 802.11 b/g products:
 - PC cards
 - PCMCIA cards
 - MiniCards/half miniCards

Features

- 2.4 to 2.5 GHz operation
- 27 dB small signal gain
- 802.11g linear power @ 3% EVM, +16 dBm
- 802.11b mask compliant power, +20 dBm
- Temperature-compensated directional RF power detector
- GaAs FET four-control transfer switch
- MCM (24-pin, 7 x 8 mm) Pb-free package (MSL3, 240 °C per JEDEC J-STD-020) package

Description

The SKY65206-13 is an integrated Intera™ Front-End Module (FEM) for 802.11b/g WLAN applications. A single supply voltage and a positive supply switch control simplify bias requirements. The device is manufactured using Skyworks InGaP Heterojunction Bipolar Transistor (HBT) process.

Modules are 100 percent tested before shipment for guaranteed performance. The SKY65206-13 is targeted for high-volume 802.11b/g WLAN access point, PCMCIA, and PC card applications.

The SKY65206-13 is packaged in a lead (Pb)-free, RoHS-compliant Multi-Chip Module (MCM). A functional block diagram is shown in Figure 1. The pin configuration and package are shown in Figure 2. Signal pin assignments and functional pin descriptions are provided Table 1.

NEW Skyworks offers lead (Pb)-free, RoHS (Restriction of Hazardous Substances) compliant packaging.

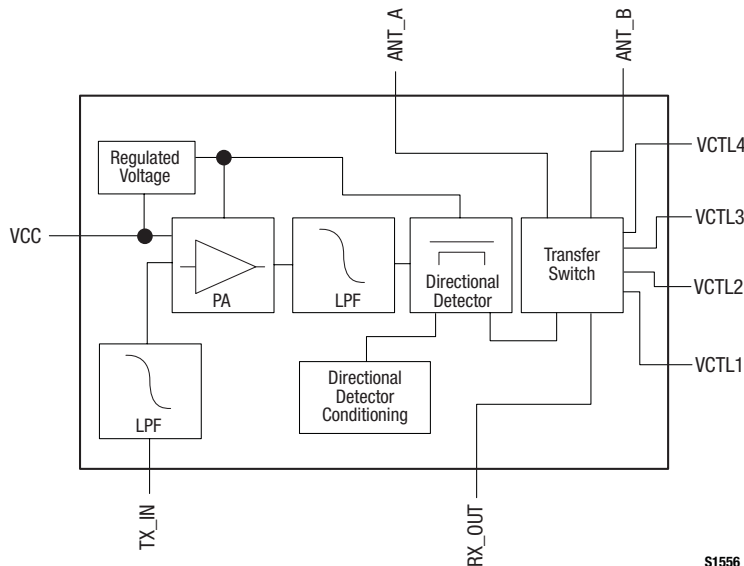

Figure 1. SKY65206-13 Block Diagram

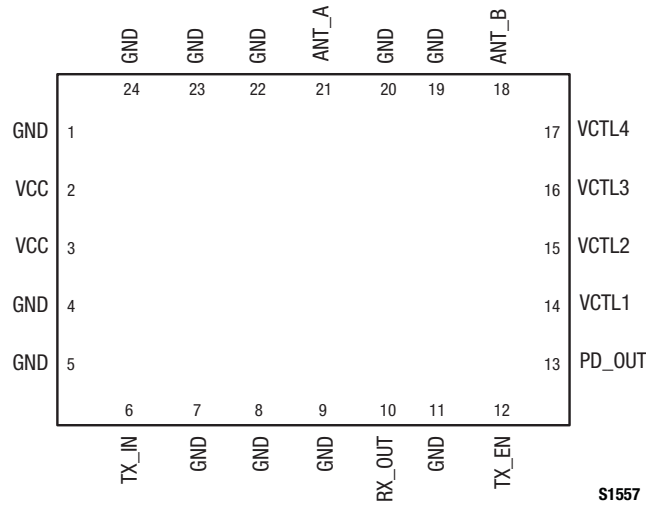

Figure 2. SKY65206-13 Pinout – 24-Pin MCM (Top View)

Table 1. SKY65206-13 Signal Descriptions

Pin #	Name	Description	Pin #	Name	Description
1	GND	Ground	13	PD_OUT	Detected output voltage from directional detector.
2	VCC	DC power supply voltage input to PA and to the internal voltage regulator that biases the internal directional detector. Pin 2 and 3 are connected for current sharing.	14	VCTL1	High impedance DC control voltage input 1 for transfer switch.
3	VCC	DC power supply voltage input to PA and to the internal voltage regulator that biases the internal directional detector. Pin 2 and 3 are connected for current sharing.	15	VCTL2	High impedance DC control voltage input 2 for transfer switch.
4	GND	Ground	16	VCTL3	High impedance DC control voltage input 3 for transfer switch.
5	GND	Ground	17	VCTL4	High impedance DC control voltage input 4 for transfer switch.
6	TX_IN	Transmitter RF input. Nominal input impedance = 50 Ω.	18	ANT_B	RF antenna I/O port B. Nominal input impedance = 50 Ω.
7	GND	Ground	19	GND	Ground
8	GND	Ground	20	GND	Ground
9	GND	Ground	21	ANT_A	RF antenna I/O port A. Nominal input impedance = 50 Ω.
10	RX_OUT	Receiver RF output. Nominal input impedance = 50 Ω.	22	GND	Ground
11	GND	Ground	23	GND	Ground
12	TX_EN	High impedance DC control voltage input to enable/disable the PA.	24	GND	Ground

Electrical and Mechanical Specifications

The absolute maximum ratings of the SKY65206-13 are provided in Table 2. The recommended operating conditions are specified in Table 3. Electrical specifications are provided in Table 4. Table 5 provides the transmit/receive switch control logic.

Typical performance characteristics of the SKY65206-13 are illustrated in Figures 3 through 10.

Table 2. SKY65206-13 Absolute Maximum Ratings

Parameter	Symbol	Minimum	Maximum	Units
RF input power	P_{IN}		+20	dBm
Supply voltage	VCC		4	V
Supply current			600	mA
Operating temperature	T_A	-40	+85	°C
Storage temperature	T_{STG}	-65	+85	°C
Thermal resistance	Θ_{JC}		55	°C/W

Note: Exposure to maximum rating conditions for extended periods may reduce device reliability. There is no damage to device with only one parameter set at the limit and all other parameters set at or below their nominal value.

CAUTION: Although this device is designed to be as robust as possible, Electrostatic Discharge (ESD) can damage this device. This device must be protected at all times from ESD. Static charges may easily produce potentials of several kilovolts on the human body or equipment, which can discharge without detection. Industry-standard ESD precautions should be used at all times.

Table 3. SKY65206-13 Recommended Operating Conditions

Parameter	Symbol	Minimum	Typical	Maximum	Units
Supply voltage	VCC	3.0	3.3	3.6	V
Control voltage	TxE _n	2.8	3.0	3.3	V
Operating temperature	T_A	0	+25	+85	°C

Table 4. SKY65206-13 Electrical Specifications (Note 1) (1 of 2)
($T_A = +25$ °C, Characteristic Impedance [Z_0] = 50 Ω , Unless Otherwise Noted)

Parameter	Symbol	Test Condition	Min	Typical	Max	Units
General RF Receive						
Frequency range	f		2400		2500	MHz
Insertion loss	S ₂₁	Small signal		1		dB
In-band ripple	Δ S ₂₁	Small signal		0.1		dB
Input return loss	S ₁₁	Small signal		19		dB
Output return loss	S ₂₂	Small signal		17		dB
General RF Transmit						
Frequency range	f	VCC = 3.3 V	2400		2500	MHz
Gain	S ₂₁	VCC = 3.3 V, small signal	25	27	31	dB
Gain variation over frequency	Δ S ₂₁	VCC = 3.3 V, small signal		1.4		dB
Quiescent current	I _{CO}	VCC = 3.3 V, no RF signal		0.12		A

Table 4. SKY65206-13 Electrical Specifications (Note 1) (2 of 2)
(T_A = +25 °C, Characteristic Impedance [Z₀] = 50 Ω, Unless Otherwise Noted)

Parameter	Symbol	Test Condition	Min	Typical	Max	Units
General RF Transmit (continued)						
Current consumption	I _{CC}	VCC = 3.3 V, CW at P _{OUT} = +16 dBm		0.17	0.19	A
Input return loss	S ₁₁	VCC = 3.3 V, small signal		11		dB
Output return loss	S ₂₂	VCC = 3.3 V, small signal		19		dB
1 dB output compression point	OP1dB	VCC = 3.3 V, CW		+23		dBm
Detector voltage	P _{DOUT}	VCC = 3.3 V CW at P _{OUT} = +4 dBm CW at P _{OUT} = +12 dBm CW at P _{OUT} = +21 dBm	0.400	0.930 0.826 0.486	0.550	V V V
802.11g OFDM Modulation						
Linear power @ 2.442 GHz	P _{OUT}	VCC = 3.3 V, 54 Mbps @ 3% EVM		+16.4		dBm
Current consumption	I _{CC}	VCC = 3.3 V, 54 Mbps @ linear power		0.17		A
802.11b CCK Modulation (Note 2)						
Linear power @ 2.442 GHz	P _{OUT}	VCC = 3.3 V, 11 Mbps		+20		dBm
Current consumption	I _{CC}	VCC = 3.3 V, 11 Mbps @ compliant power		0.23		A

Note 1: Performance is guaranteed only under the conditions listed in this Table and is not guaranteed over the full operating or storage temperature ranges. Exceeding any of the conditions listed here may result in permanent damage to the device. Operation at elevated temperatures may reduce reliability of the device.

Note 2: 802.11b data is taken with a raised cosine filter and an alpha factor of 0.7.

Table 5. Transmit/Receive Mode Switch Control Logic

Mode	VCTL1 (V)	VCTL2 (V)	VCTL3 (V)	VCTL4 (V)	VCC (V)	TX_EN (V)
Receive (ANT_A)	0	3.3	0	0	3.3	0
Receive (ANT_B)	0	0	3.3	0	3.3	0
Transmit (ANT_A)	3.3	0	0	0	3.3	3.0
Transmit (ANT_B)	0	0	0	3.3	3.3	3.0

Note: All other conditions are not recommended.

Typical Performance Characteristics

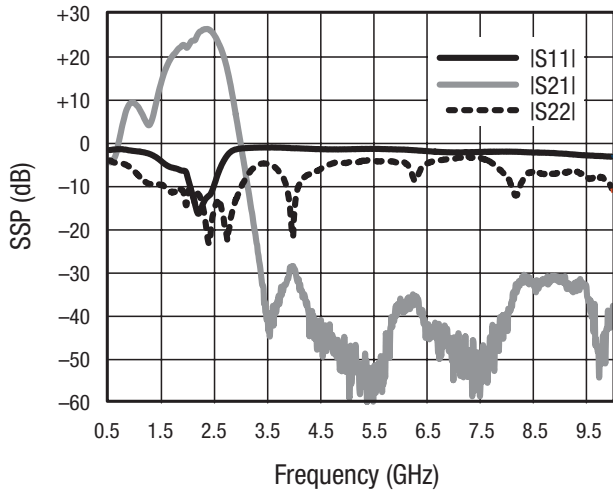

Figure 3. Small Signal Transmit Parameters (Broadband)
(VCC = 3.3 V, TA = 25 °C)

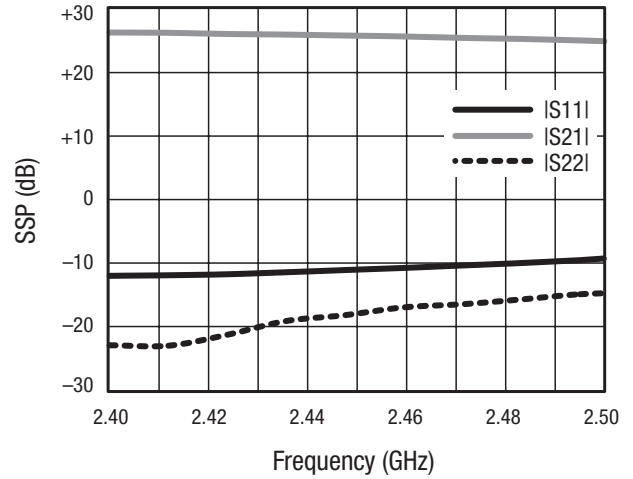

Figure 4. Small Signal Transmit Parameters (Narrowband)
(VCC = 3.3 V, TA = 25 °C)

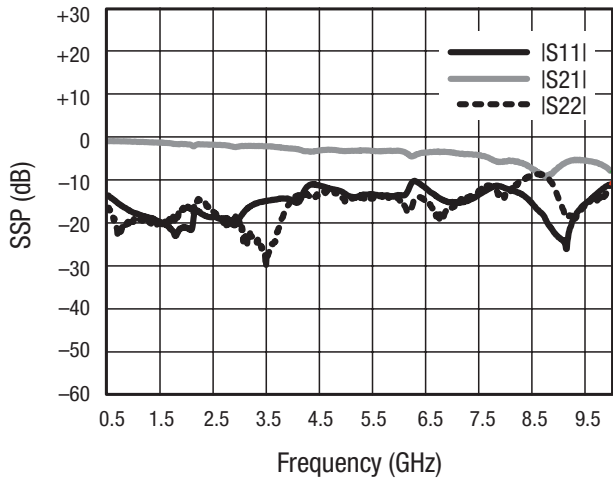

Figure 5. Small Signal Receive Parameters (Broadband)
(TA = 25 °C)

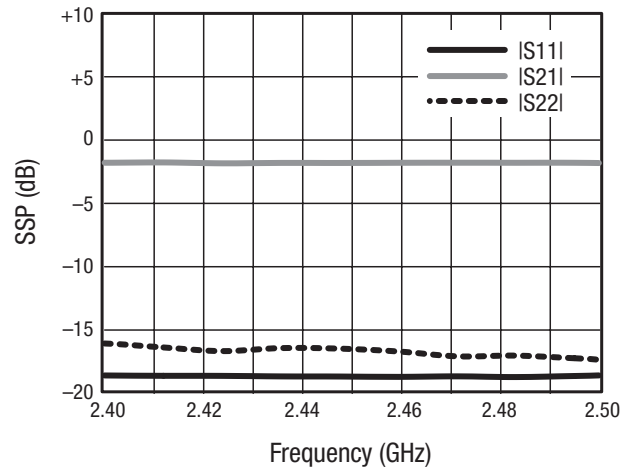

Figure 6. Small Signal Receive Parameters (Narrowband)
(TA = 25 °C)

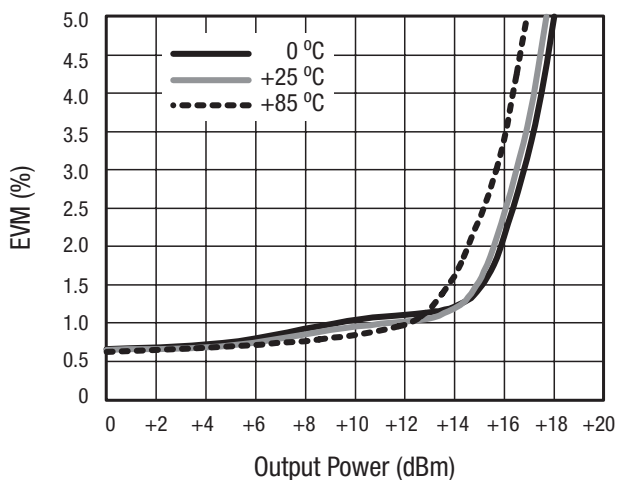

Figure 7. EVM vs Output Power
(VCC = 3.3 V, f = 2.450 GHz, OFDM = 54 Mbps)

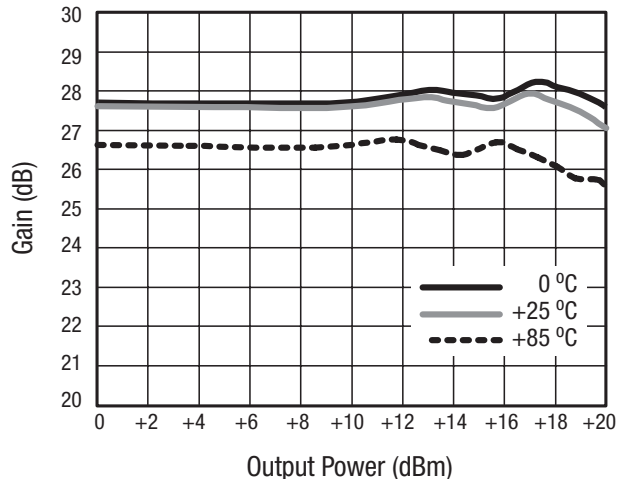

Figure 8. Gain vs Output Power
(VCC = 3.3 V, f = 2.442 GHz, OFDM = 54 Mbps)

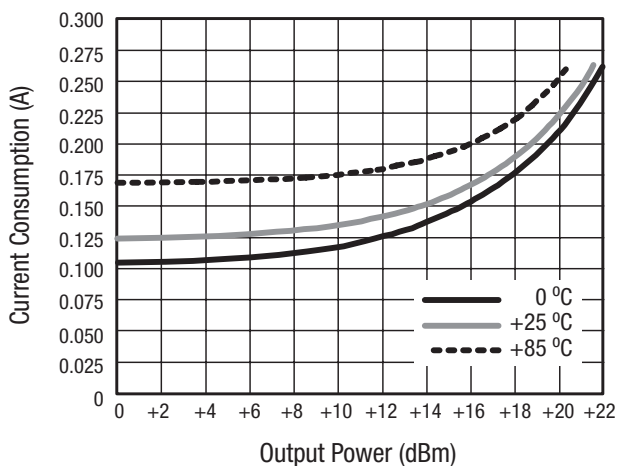

Figure 9. Current Consumption vs Output Power
(VCC = 3.3 V, f = 2.450 GHz, OFDM = 54 Mbps)

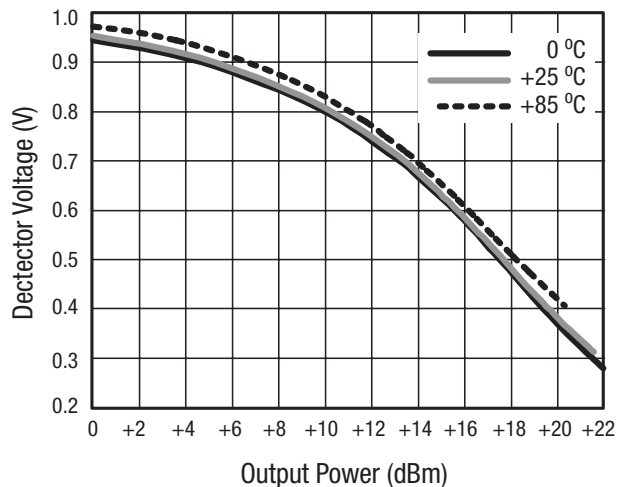

Figure 10. Detector Voltage vs Output Power
(VCC = 3.3 V, f = 2.450 GHz, OFDM = 54 Mbps)

Evaluation Board Description

The SKY65206 Evaluation Board is used to test the performance of the SKY65206-13 FEM. An assembly drawing for the Evaluation Board is shown in Figure 11. A schematic diagram of the SKY65206 Evaluation Board is shown in Figure 12.

Circuit Design Configurations

The following design considerations are general in nature and must be followed regardless of final use or configuration:

1. Paths to ground should be made as short as possible.
2. The ground pads of the SKY65206-13 have special electrical and thermal grounding requirements. These pads are the main thermal conduit for heat dissipation. Since the circuit board acts as the heat sink, it must shunt as much heat as possible from the device. Therefore, design the connection to the ground pads to dissipate the maximum wattage produced by the circuit board.
3. Skyworks recommends including external bypass capacitors on the VCC voltage inputs of the device.

Evaluation Board Test Procedure

- Step 1: Connect a 3.3 V supply to VCC (see Figure 11). If available, enable the current limiting function of the power supply to 600 mA.
- Step 2: Connect a 3.3 V supply to VCTL1, 2, 3, and 4 (these are ports C1, 2, 3, and 4, respectively, on the Evaluation Board). Any unused VCTL pins must be grounded or set to 0 V. Do not float the connections.
- Step 3: Connect a 3.0 V supply to TX_EN (see Figure 11).
- Step 4: Connect a digital volt meter to PD_OUT (see Figure 11).
- Step 5: Connect a signal generator to the RF signal input port. Set it to the desired RF frequency at a power level of -15 dBm or less to the Evaluation Board but DO NOT enable the RF signal.
- Step 6: Connect a spectrum analyzer to the RF signal output port.

CAUTION: Terminate all unused ports in 50Ω .

Step 7: Enable the power supplies.

Step 8: Enable the RF signal.

Step 9: Take measurements.

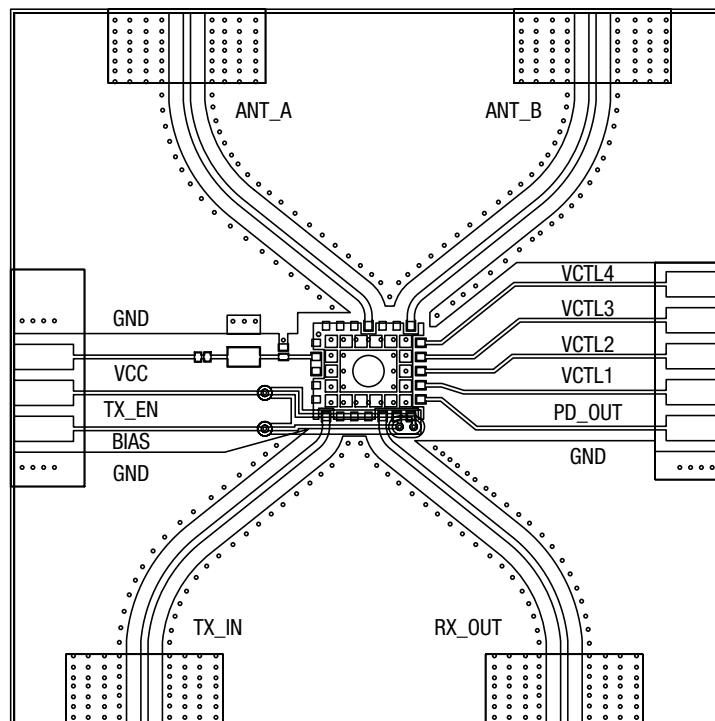

S1558

Figure 11. SKY65206-13 Evaluation Board Assembly Drawing

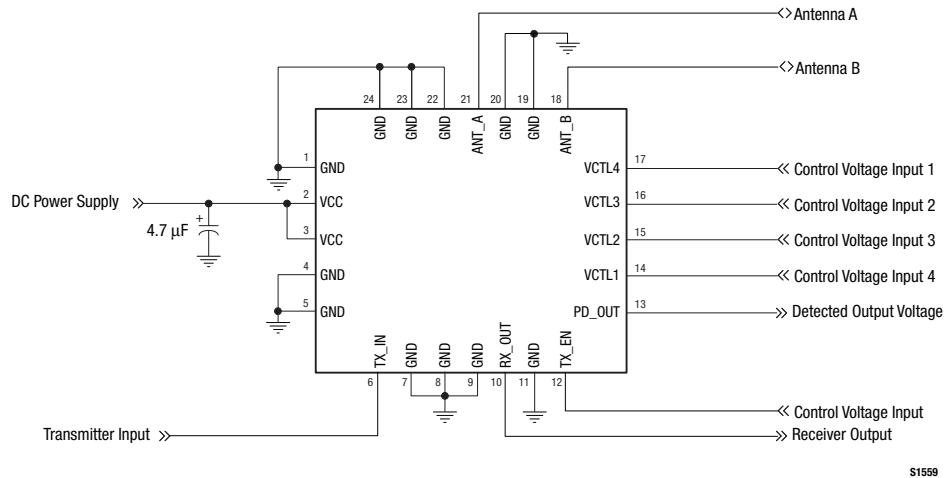

Figure 12. SKY65206-13 Application Circuit

Package Dimensions

The PCB layout footprint for the SKY65206-13 is provided in Figure 13. Typical case markings are shown in Figure 14. Figure 15 provides the package dimensions for the 24-pin MCM and tape and reel dimensions are provided in Figure 16.

Package and Handling Information

Since the device package is sensitive to moisture absorption, it is baked and vacuum packed before shipping. Instructions on the shipping container label regarding exposure to moisture after the container seal is broken must be followed. Otherwise, problems related to moisture absorption may occur when the part is subjected to high temperature during solder assembly.

The SKY65206-13 is rated to Moisture Sensitivity Level 3 (MSL3) at 240 °C. It can be used for lead or lead-free soldering. For

additional information, refer to the Skyworks Application Note, *PCB Design & SMT Assembly/Rework Guidelines for MCM-L Packages*, document number 101752.

Care must be taken when attaching this product, whether it is done manually or in a production solder reflow environment. Production quantities of this product are shipped in a standard tape and reel format. For packaging details, refer to the Skyworks Application Note, *Tape and Reel*, document number 101568.

Electrostatic Discharge (ESD) Sensitivity

The SKY65206-13 is a static-sensitive electronic device. Do not operate or store near strong electrostatic fields. Take proper ESD precautions.

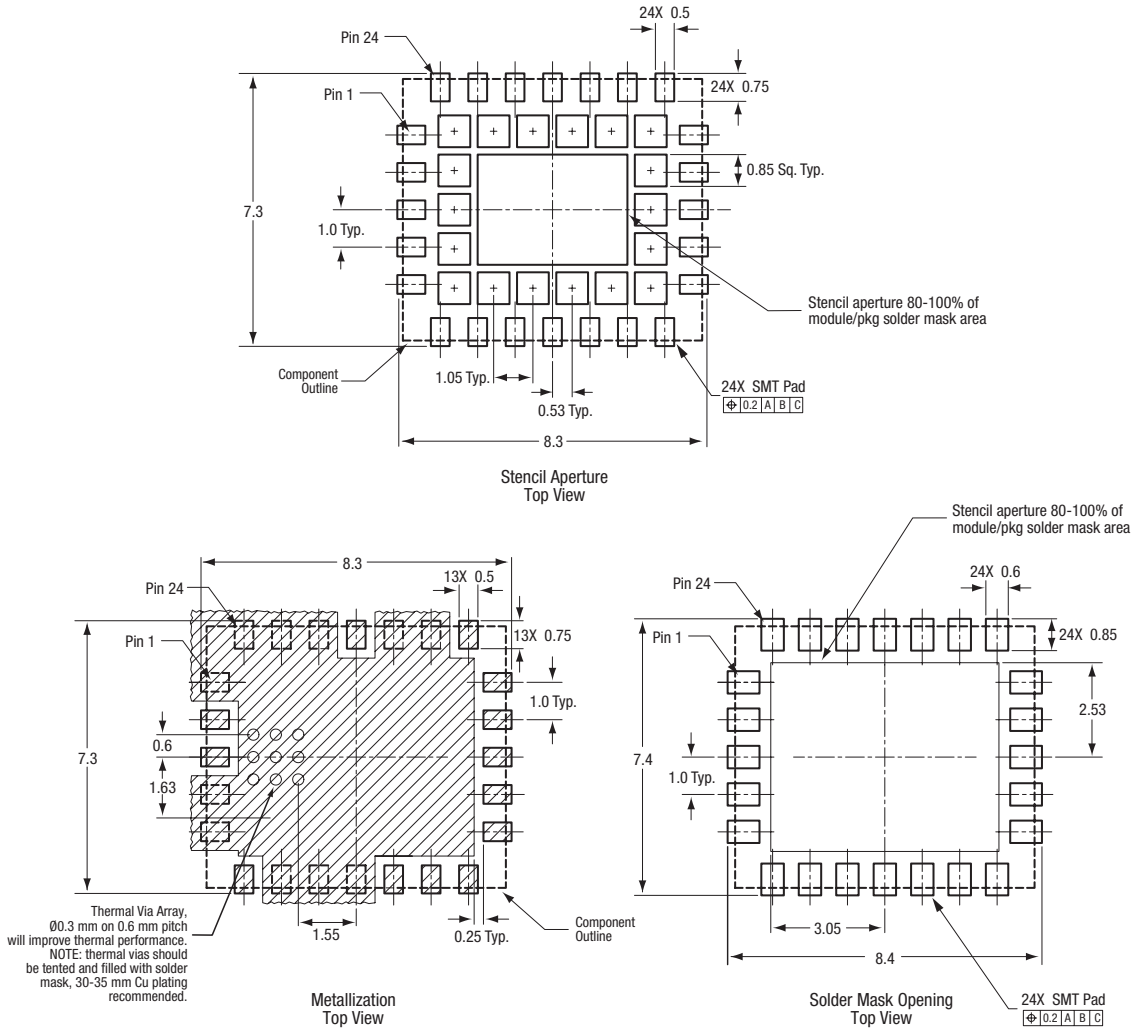

All dimensions are in millimeters

S1573

Figure 13. Board Layout Footprint for the SKY65206-13 4 x 4 mm MCM

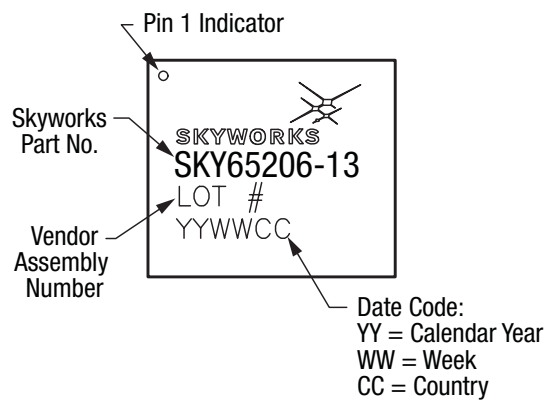
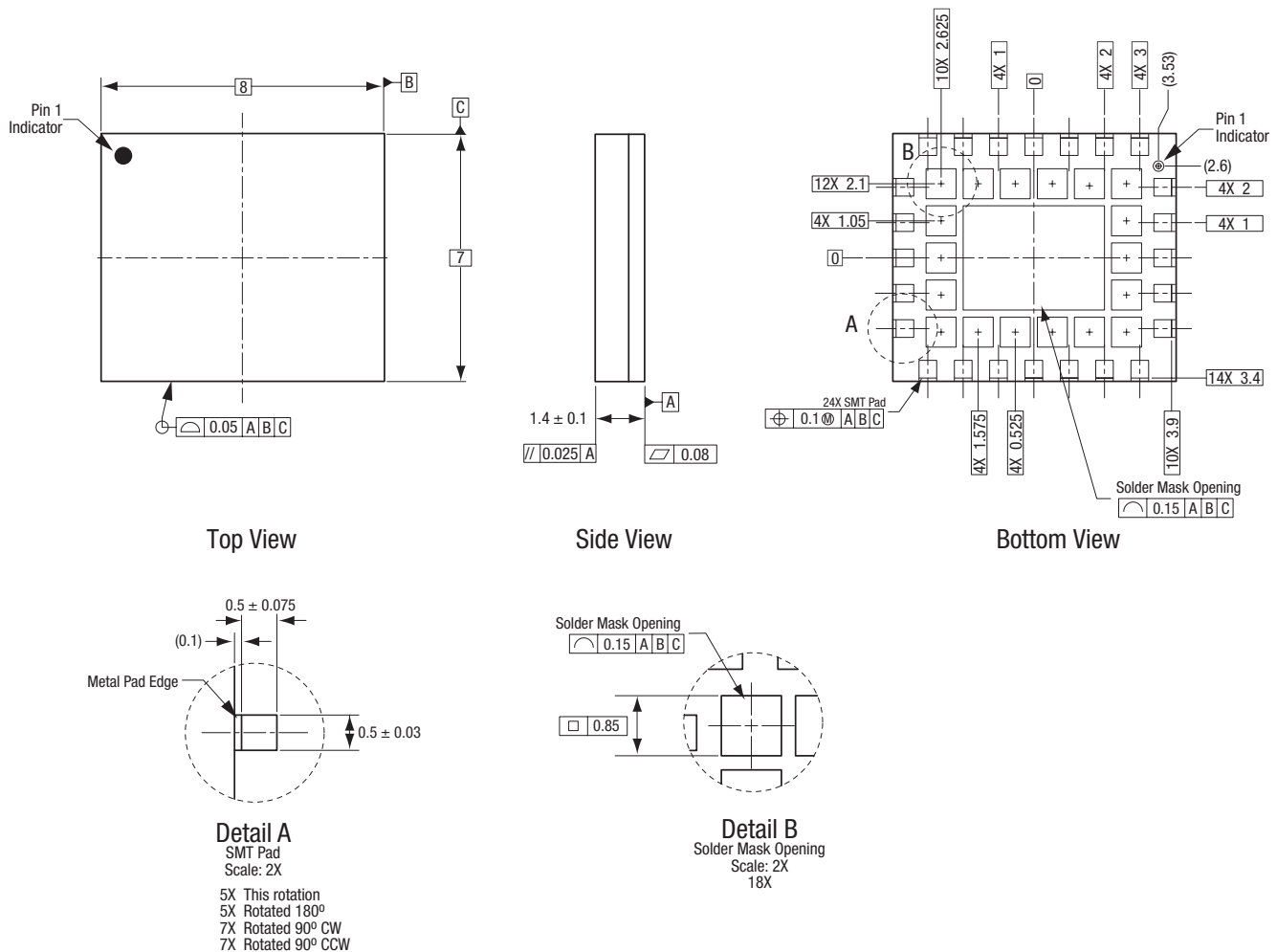

Figure 14. Typical Case Markings (Top View)



All measurements are in millimeters.
Dimensioning and tolerancing according to ASME Y14.5M-1994.

S1560

Figure 15. SKY65206-13 20-Pin MCM Package Dimensions

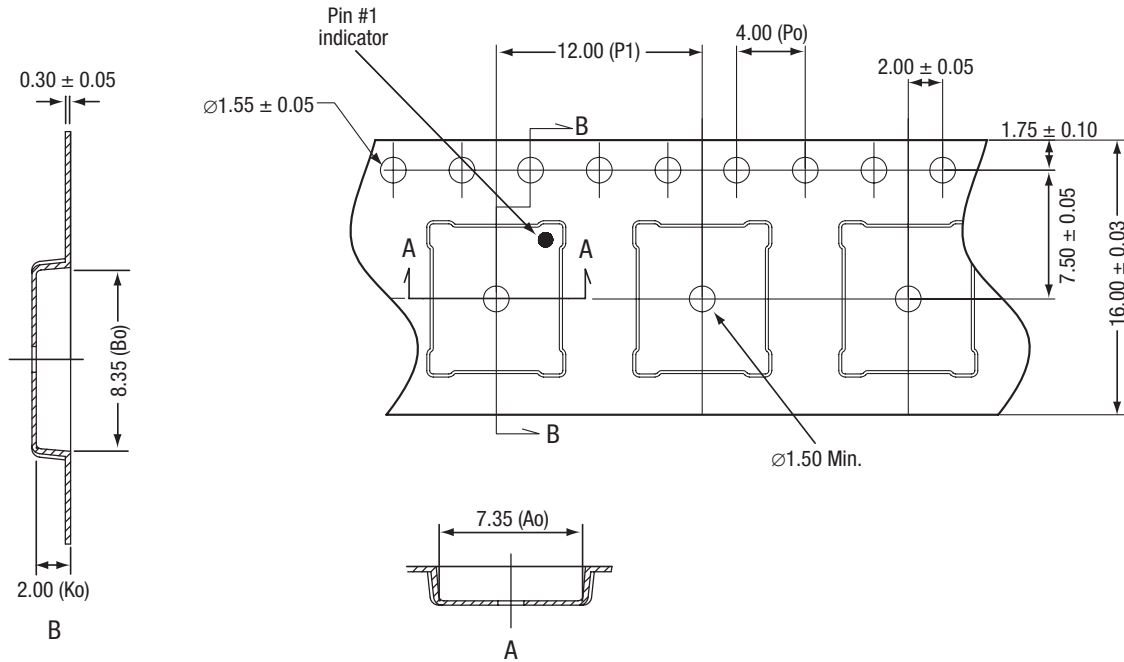

- Notes:
1. Carrier tape material: black conductive polystyrene
 2. Cover tape material: transparent conductive PSA
 3. Cover tape size: 13.3 mm width
 4. Ao and Bo measurement point to be 0.30 from bottom pocket.
 4. All measurements are in millimeters

S1561

Figure 16. SKY65206-13 Tape and Reel Dimensions

Ordering Information

Model Name	Ordering Part Number	Evaluation Board Part Number
SKY65206-13 WLAN 801.11 b/g Front-End Moduler	SKY65206-13 (Pb-free package)	SK40350, rev. 2

Copyright © 2008, 2009 Skyworks Solutions, Inc. All Rights Reserved.

Information in this document is provided in connection with Skyworks Solutions, Inc. ("Skyworks") products or services. These materials, including the information contained herein, are provided by Skyworks as a service to its customers and may be used for informational purposes only by the customer. Skyworks assumes no responsibility for errors or omissions in these materials or the information contained herein. Skyworks may change its documentation, products, services, specifications or product descriptions at any time, without notice. Skyworks makes no commitment to update the materials or information and shall have no responsibility whatsoever for conflicts, incompatibilities, or other difficulties arising from any future changes.

No license, whether express, implied, by estoppel or otherwise, is granted to any intellectual property rights by this document. Skyworks assumes no liability for any materials, products or information provided hereunder, including the sale, distribution, reproduction or use of Skyworks products, information or materials, except as may be provided in Skyworks Terms and Conditions of Sale.

THE MATERIALS, PRODUCTS AND INFORMATION ARE PROVIDED "AS IS" WITHOUT WARRANTY OF ANY KIND, WHETHER EXPRESS, IMPLIED, STATUTORY, OR OTHERWISE, INCLUDING FITNESS FOR A PARTICULAR PURPOSE OR USE, MERCHANTABILITY, PERFORMANCE, QUALITY OR NON-INFRINGEMENT OF ANY INTELLECTUAL PROPERTY RIGHT; ALL SUCH WARRANTIES ARE HEREBY EXPRESSLY DISCLAIMED. SKYWORKS DOES NOT WARRANT THE ACCURACY OR COMPLETENESS OF THE INFORMATION, TEXT, GRAPHICS OR OTHER ITEMS CONTAINED WITHIN THESE MATERIALS. SKYWORKS SHALL NOT BE LIABLE FOR ANY DAMAGES, INCLUDING BUT NOT LIMITED TO ANY SPECIAL, INDIRECT, INCIDENTAL, STATUTORY, OR CONSEQUENTIAL DAMAGES, INCLUDING WITHOUT LIMITATION, LOST REVENUES OR LOST PROFITS THAT MAY RESULT FROM THE USE OF THE MATERIALS OR INFORMATION, WHETHER OR NOT THE RECIPIENT OF MATERIALS HAS BEEN ADVISED OF THE POSSIBILITY OF SUCH DAMAGE.

Skyworks products are not intended for use in medical, lifesaving or life-sustaining applications, or other equipment in which the failure of the Skyworks products could lead to personal injury, death, physical or environmental damage. Skyworks customers using or selling Skyworks products for use in such applications do so at their own risk and agree to fully indemnify Skyworks for any damages resulting from such improper use or sale.

Customers are responsible for their products and applications using Skyworks products, which may deviate from published specifications as a result of design defects, errors, or operation of products outside of published parameters or design specifications. Customers should include design and operating safeguards to minimize these and other risks. Skyworks assumes no liability for applications assistance, customer product design, or damage to any equipment resulting from the use of Skyworks products outside of stated published specifications or parameters.

Skyworks, the Skyworks symbol, and "Breakthrough Simplicity" are trademarks or registered trademarks of Skyworks Solutions, Inc., in the United States and other countries. Third-party brands and names are for identification purposes only, and are the property of their respective owners. Additional information, including relevant terms and conditions, posted at www.skyworksinc.com, are incorporated by reference.