

DATA SHEET

SKY77768 Power Amplifier Module for WCDMA/ HSDPA/ HSUPA/ HSPA+/ LTE – Band VIII (880–915 MHz)

Applications

- WCDMA handsets
- HSDPA
- HSUPA
- HSPA+
- LTE

Features

- Low voltage positive bias supply 3.2 V to 4.2 V
- Good linearity
- High efficiency
 - 50% at 28.5 dBm
- Large dynamic range
- Small, low profile package
 - 3 mm x 3 mm x 0.9 mm
 - 10-pad configuration
- Power down control
- InGaP
- Supports low collector voltage operation
- Digital Enable
- No V_{REF} required
- CMOS compatible control signals
- Integrated Directional Coupler

Description

The SKY77768 Power Amplifier Module (PAM) is a fully matched 10-pad surface mount module developed for Wideband Code Division Multiple Access (WCDMA) applications. This small and efficient module packs full 880-915 MHz bandwidth coverage into a single compact package. Because of high efficiencies attained throughout the entire power range, the SKY77768 delivers unsurpassed talk-time advantages. The SKY77768 meets the stringent spectral linearity requirements of High Speed Downlink Packet Access (HSDPA), High Speed Uplink Packet Access (HSUPA), and Long Term Evolution (LTE) data transmission with high power added efficiency. An integrated directional coupler eliminates the need for any external coupler.

The Gallium Arsenide (GaAs) Microwave Monolithic Integrated Circuit (MMIC) contains all amplifier active circuitry, including input and interstage matching circuits. The silicon CMOS support die, providing precision biasing for the MMIC affords a true CMOS-compatible control interface. Output match into a 50-ohm load, realized off-chip within the module package, optimizes efficiency and power performance.

The SKY77768 is manufactured with Skyworks' InGaP GaAs Heterojunction Bipolar Transistor (HBT) process which provides for all positive voltage DC supply operation and maintains high efficiency and good linearity. While primary bias to the SKY77768 can be supplied directly from any suitable battery with an output of 3.2 V to 4.2 V, optimal performance is obtained with VCC2 sourced from a DCDC power supply adjusted within 0.5 V to 3.6 V based on target output power levels. Power down executes by setting VENABLE to zero volts. No external supply side switch is needed as typical "off" leakage is a few microamperes with full primary voltage supplied from the battery.

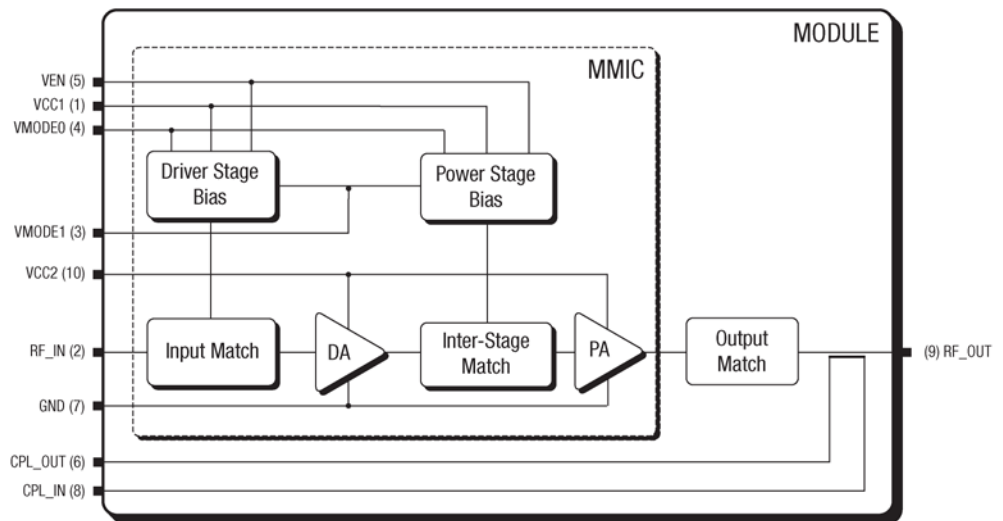
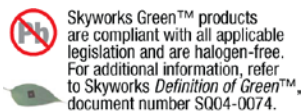

Figure 1. SKY77768 Functional Block Diagram

201722_001

Electrical Specifications

The following tables list the electrical characteristics of the SKY77768 Power Amplifier. Table 1 lists the absolute maximum ratings and Table 2 shows the recommended operating conditions. Electrical specifications for nominal operating

conditions are listed in Table 4. Table 3 presents a truth table for the power settings. Tables 5 through 8 provide the standard test configurations for WCDMA (STC1), HSDPA (STC2), and HSUPA (STC3, STC4) respectively.

Table 1. Absolute Maximum Operating Conditions
No damage assuming only one parameter set at limit at a time with all other parameters set at nominal value.

Parameter	Symbol	Minimum	Nominal	Maximum	Unit
RF Input Power	P _{IN}	—	0	10	dBm
Supply Voltage	No RF V _{CC1}	—	3.4	6.0	Volts
	With RF V _{CC2}	—	—	4.6	
Enable Control Voltage	V _{EN}	—	1.8	4.2	Volts
Mode Control Voltage	V _{MODE0}	—	1.8	4.2	Volts
	V _{MODE1}	—	1.8	4.2	
Case Temperature ¹	Operating T _{CASE}	-30	25	+110	°C
	Storage T _{STG}	-40	—	+150	

¹ Case Operating Temperature (T_{CASE}) refers to the temperature of the GROUND PAD at the underside of the package.

Table 2. Recommended Operating Conditions

Parameter	Symbol	Minimum	Nominal	Maximum	Unit
RF Output Power ¹	WCDMA P _{OUT_MAX}	28.50	—	—	dBm
	HSDPA	27.50	—	—	
	HSUPA	24.85	—	—	
	LTE	27.50	—	—	
Operating Frequency	f ₀	880.0	897.5	915.0	MHz
Supply Voltage	V _{CC1} , V _{CC2}	3.2 ²	3.4	4.2	Volts
Enable Control Voltage	Low V _{EN_L}	0.0	0.0	0.5	Volts
	High V _{EN_H}	1.35	1.8	3.1	
Mode Control Voltage	Low	V _{MODE0}	0.0	0.0	Volts
		V _{MODE1}	0.0	0.0	
	High	V _{MODE0}	1.35	1.8	
		V _{MODE1}	1.35	1.8	
Case Operating Temperature	T _{CASE}	-20	+25	+85	°C

¹ For V_{CC} < 3.4 V, output power back-off = 0.5 dB.

² Recommended minimum V_{CC} for maximum power output is indicated. V_{CC2} down to 0.5 V may be used for backed-off power when using DC/DC converter to conserve battery current.

³ Equivalent to -30 °C to +75 °C Ambient Operating Temperature

Table 3. Modes of Operation

Power Setting	ENABLE	VMODE0	VMODE1	VCC
Power Down Mode	Low	Low	Low	On
Standby Mode	Low	—	—	On
High Power Mode (17.0 dBm ≤ P _{OUT} ≤ 28.5 dBm)	High	Low	—	On
Medium Power Mode (7.0 dBm ≤ P _{OUT} ≤ 17.0 dBm)	High	High	Low	On
Low Power Mode (P _{OUT} ≤ 7.0 dBm)	High	High	High	On

Table 4. Electrical Specifications for Nominal Operating Conditions

Per Table 2 over dynamic range up to 28.5 dBm output power for STC1 modulation, unless otherwise specified.

Characteristics	Symbol	Condition	Minimum	Typical	Maximum	Unit	
Gain ¹	GLOW	P _{OUT} = 7.0 dBm V _{CC2} = 0.8 V	10.0	14.0	21.5	dB	
	GMED	P _{OUT} = 17.0 dBm V _{CC2} = 1.5 V	19.0	24.0	28.0		
	GHIGH	P _{OUT} = 28.5 dBm	25.0	28.0	31.0		
Rx Band Gain	RxG	—	—	—	-0.5	dB	
	RxG_GPS	—	—	—	-3.0		
	RxG_JSM	—	—	—	-6.0		
Power Added Efficiency	PAE _{LOW}	P _{OUT} = 7.0 dBm	10.5	13.0	—	%	
	PAE _{MED}	P _{OUT} = 17.0 dBm	22.0	26.5	—		
	PAE _{HIGH}	P _{OUT} = 28.5 dBm	43.0	50.0	—		
Total Supply Current	I _{CC_LOW}	P _{OUT} = 7.0 dBm	—	44	55	mA	
	I _{CC_MED}	P _{OUT} = 17.0 dBm	—	122	150		
	I _{CC_HIGH}	P _{OUT} = 28.5 dBm	—	420	500		
Quiescent Current	I _{Q_LOW}	Low Power Mode	—	22	28	mA	
	I _{Q_MED}	Medium Power Mode	—	38	45		
Enable Control Current	I _{EN}	—	—	20	40	μA	
Mode Control Current	I _{MODE0}	—	—	20	40	μA	
	I _{MODE1}	—	—	20	40		
Total Supply Current in Power Down Mode	I _{PD}	V _{CC} = 3.4 V V _{EN} = Low V _{MODE0} = Low V _{MODE1} = Low	—	—	20	μA	
ICC1 Current	I _{CC1_HIGH}	—	—	—	10	mA	
Adjacent Channel Leakage power Ratio ²	5 MHz offset	ACLR5	P _{OUT} = 7.0 dBm	—	-43	-40.0	dBc
			P _{OUT} = 17.0 dBm	—	-45	-40.0	
			P _{OUT} = 28.5 dBm	—	-41	-38.5	
	10 MHz offset	ACLR10	P _{OUT} = 7.0 dBm	—	-59	-50.0	
			P _{OUT} = 17.0 dBm	—	-56	-50.0	
			P _{OUT} = 28.5 dBm	—	-58	-50.0	

Table 4. [continued] **Electrical Specifications for Nominal Operating Conditions**
Per Table 2 over dynamic range up to 28.5 dBm output power for STC1 modulation, unless otherwise specified.

Characteristics	Symbol	Condition	Minimum	Typical	Maximum	Unit	
Adjacent Channel Leakage power Ratio ³	EUTRA offset	ACLR_EUTRA	$P_{OUT} \leq (P_{OUT_MAX} - MPR^4)$	—	-40	—	dBc
	UTRA offset	ACLR1_UTRA	—	—	-42	—	
		ACLR2_UTRA	—	—	—	—	
Harmonic Suppression	Second	fo2	$P_{OUT} \leq 28.5$ dBm	—	-45	-35	dBc
	Third	fo3		—	-50	-45	
Tx Noise in Rx Bands ¹	Rx Band 1		925 MHz–960 MHz	—	-136	-134	dBm/Hz
	GPS Rx		1574 MHz–1577 MHz	—	—	-140	
	ISM Rx		2400 MHz–2483.5 MHz	—	—	-143	
EVM		EVM1	$P_{OUT} = P_{OUT_MAX}$	—	—	3.35	%
		EVM2	$P_{OUT} = P_{OUT_MAX} - 3$	—	—	2.50	
Rise / Fall Time	DC	TON_DC	—	—	—	20	μ s
		TOFF_DC	—	—	—	20	
	RF	TON_RF	—	—	—	6	
		TOFF_RF	—	—	—	6	
Coupling Factor	CPL	$P_{OUT} = P_{OUT_MAX}$	-22	-20	-18	dB	
CPL_OUT / P _{OUT} Power Ratio Variation Over Output VSWR			2.5:1 VSWR at P _{OUT} all VSWR phases CPL_IN 50 Ω terminated	—	± 0.4	—	dB
Daisy-chain	VSWR		CPL_IN and CPL_OUT ports 698 MHz to 2620 MHz VEN = Low	—	—	1.3:1	
	Insertion Loss		CPL_IN to CPL_OUT ports 698 MHz to 2620 MHz VEN = Low	—	—	0.45	dB
Input Voltage Standing Wave Ratio	VSWR		—	—	1.2:1	1.9:1	—
Stability (Spurious output) ¹	S		6:1 VSWR All phases	—	—	-70	dBc
Ruggedness – no damage ^{1,5}	Ru		$P_{OUT} \leq 28.5$ dBm	10:1	—	—	VSWR

¹ Over conditions

² ACLR is expressed as a ratio of total adjacent power to WCDMA modulated in-band, both measured in 3.84 MHz bandwidth at specified offsets.

³ LTE: EVM and ACLR are measured with QPSK modulation with 1.4 MHz bandwidth and 5 resource blocks. (Maximum Power Reduction = 0 dBm per 3GPP TS36.101.

⁴ MPR is the maximum power reduction as defined in 3GPP TS36.101

⁵ All phases, time = 10 seconds.

Table 5. Standard Test Configuration – STC1 WCDMA Mode

Parameter	Level	Spread Code	Spread Factor	I/Q	β_c	β_d	β_{hs}	β_{ec}	β_{ed}	Relative Power (dB)
DPCCH	15 kbps	0	256	Q	8/15	—	—	—	—	-6.547
DPDCH	60 kbps	16	64	I	—	15/15	—	—	—	-1.087

Table 6. Standard Test Configuration – STC2 HSDPA Mode

Parameter	Level	Spread Code	Spread Factor	I/Q	β_c	β_d	β_{hs}	β_{ec}	β_{ed}	Relative Power (dB)
DPCCH	15 kbps	0	256	Q	12/15	—	—	—	—	-7.095
DPDCH	60 kbps	16	64	I	—	15/15	—	—	—	-5.157
HS-DPCCH	15 kbps	64	256	Q	—	—	24/15	—	—	-3.012

Table 7. Standard Test Configuration – STC3 HSUPA Mode

Parameter	Level	Spread Code	Spread Factor	I/Q	β_c	β_d	β_{hs}	β_{ec}	β_{ed}	Relative Power (dB)
DPCCH	15 kbps	0	256	Q	8/15	—	—	—	—	-19.391
DPDCH	960 kbps	1	4	I	—	15/15	—	—	—	-13.931
HS- DPCCH	15 kbps	64	256	Q	—	—	8/15	—	—	-19.391
E-DPCCH	15 kbps	1	256	I	—	—	—	10/15	—	-17.338
E-DPDCH	960 kbps	2	4	I	—	—	—	—	71.5/15	-0.371

Table 8. Standard Test Configuration – STC4 HSUPA Mode

Parameter	Level	Spread Code	Spread Factor	I/Q	β_c	β_d	β_{hs}	β_{ec}	β_{ed}	Relative Power (dB)
DPCCH	15 kbps	0	256	Q	6/15	—	—	—	—	-12.499
DPDCH	960 kbps	1	4	I	—	15/15	—	—	—	-4.540
HS- DPCCH	15 kbps	64	256	Q	—	—	2/15	—	—	-22.041
E-DPCCH	15 kbps	1	256	I	—	—	—	12/15	—	-6.478
E-DPDCH	960 kbps	2	4	I	—	—	—	—	15/15	-4.425

Evaluation Board Description

The evaluation board is a platform for testing and interfacing design circuitry. To accommodate the interface testing of the SKY77768, the evaluation board schematic and assembly diagrams are included for preliminary analysis and design. Figure

2 shows the basic schematic of the board for the 880 MHz to 915 MHz range shown in Figure 3. Figure 4 is a schematic of the recommended application shown in Figure 5.

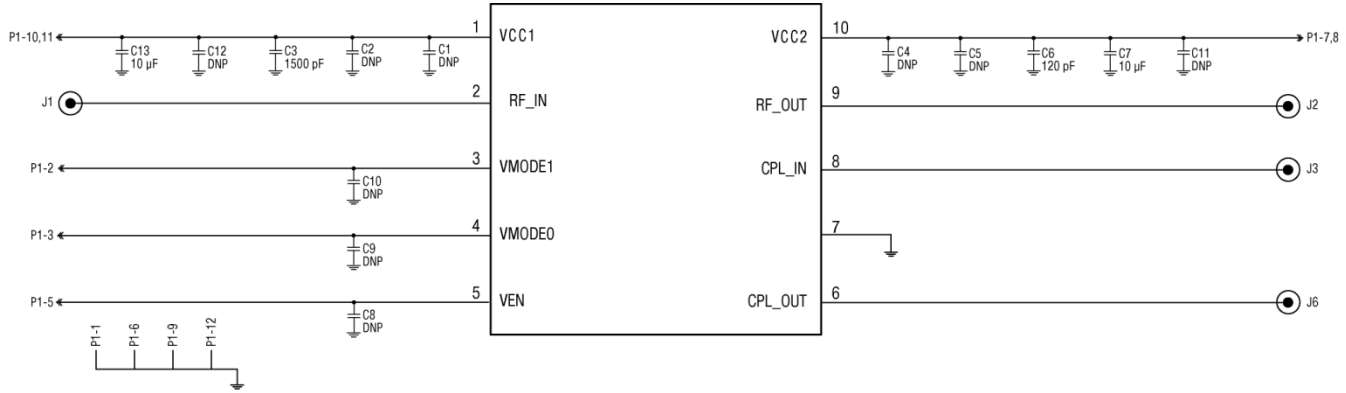

201722_002

Figure 2. Evaluation Board Schematic

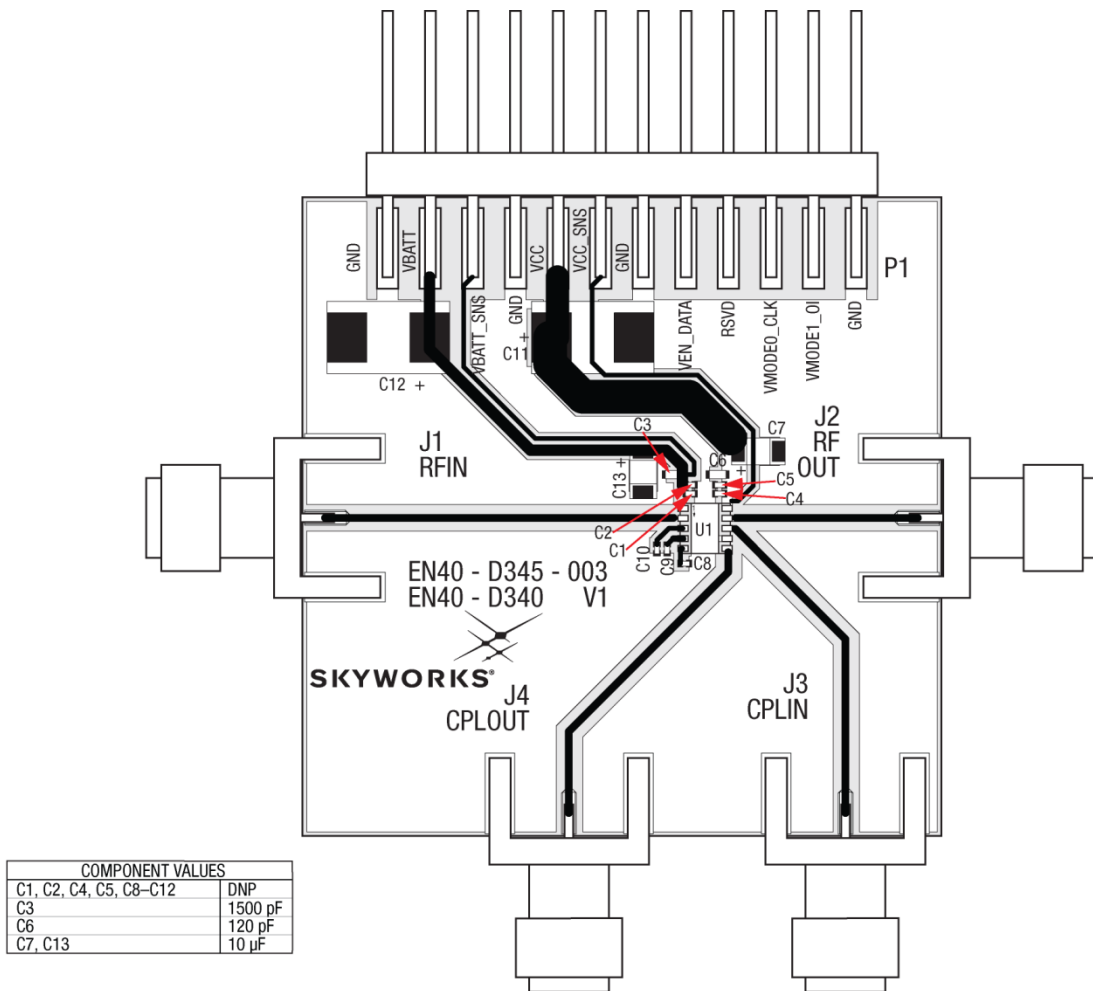

201722_003

Figure 3. Evaluation Board Assembly Diagram

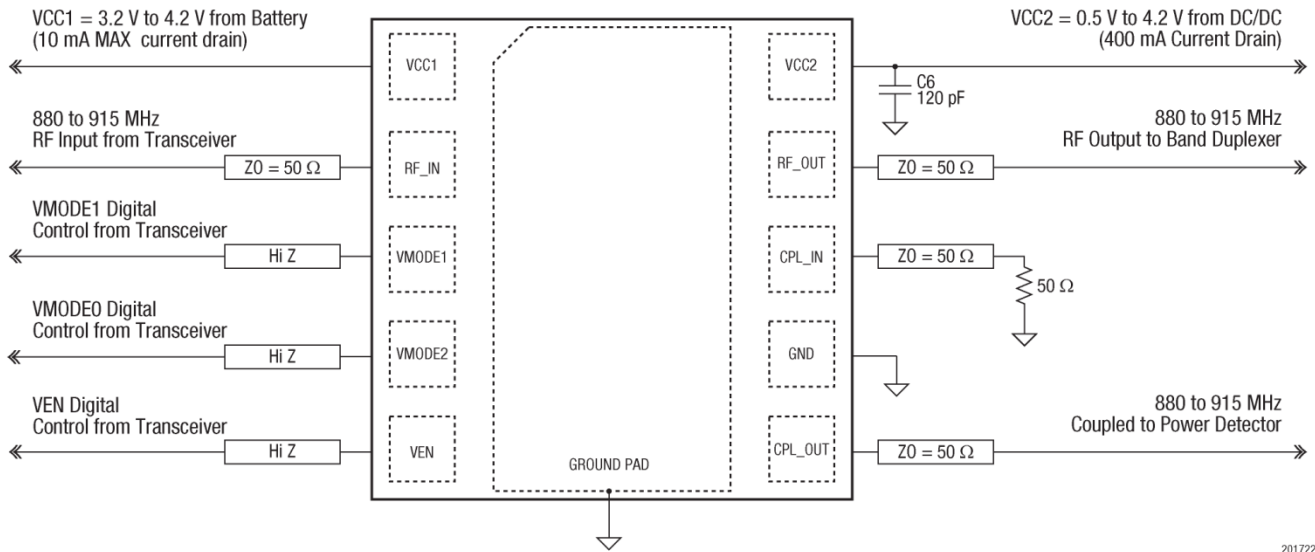

Figure 4. SKY7768 Schematic for Recommended Application Diagram

201722_004

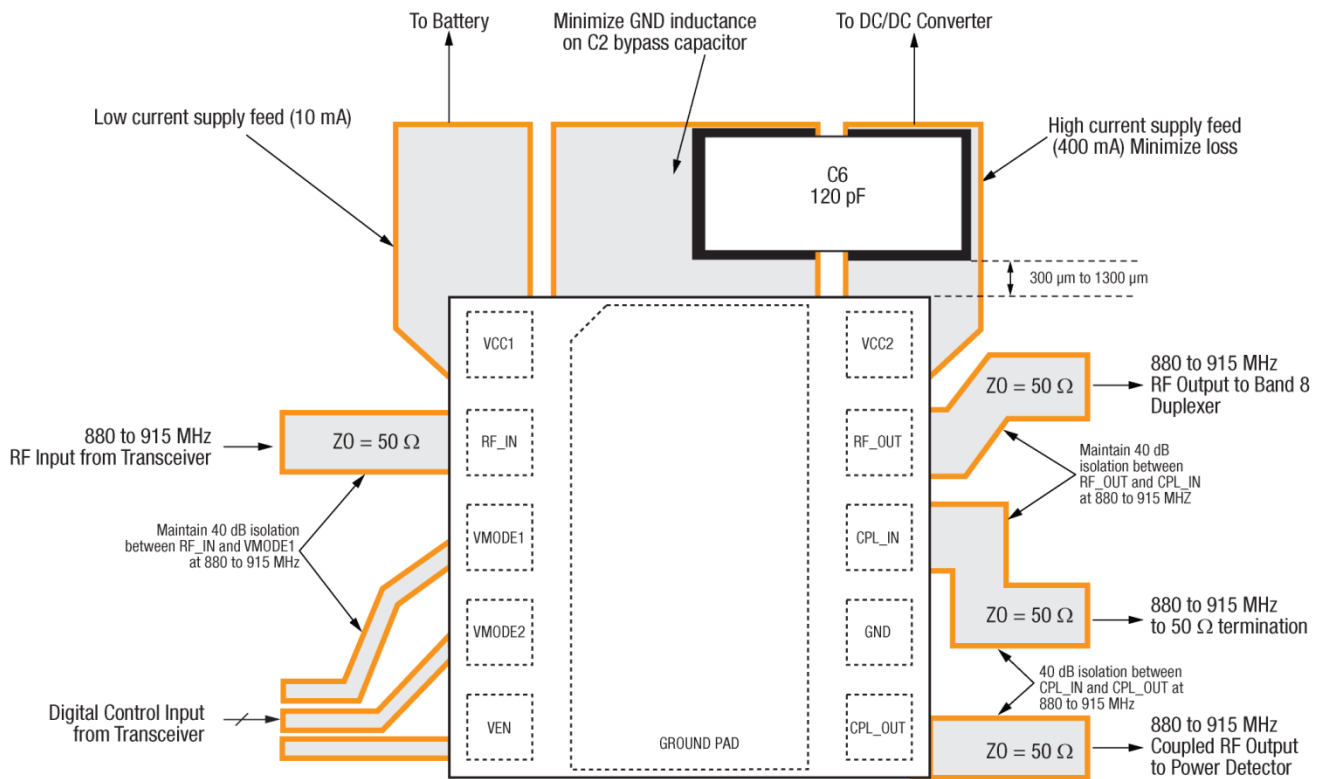

Figure 5. SKY7768 Recommended Application Diagram

201722_005

Package Dimensions

The SKY77768 is a multi-layer laminate base, overmold encapsulated modular package designed for surface mount solder attachment to a printed circuit board. Figure 6 is a mechanical drawing of the pad layout for this package. Figure 7 provides a

recommended phone board layout footprint for the PAM to help the designer attain optimum thermal conductivity, good grounding, and minimum RF discontinuity for the 50-ohm terminals.

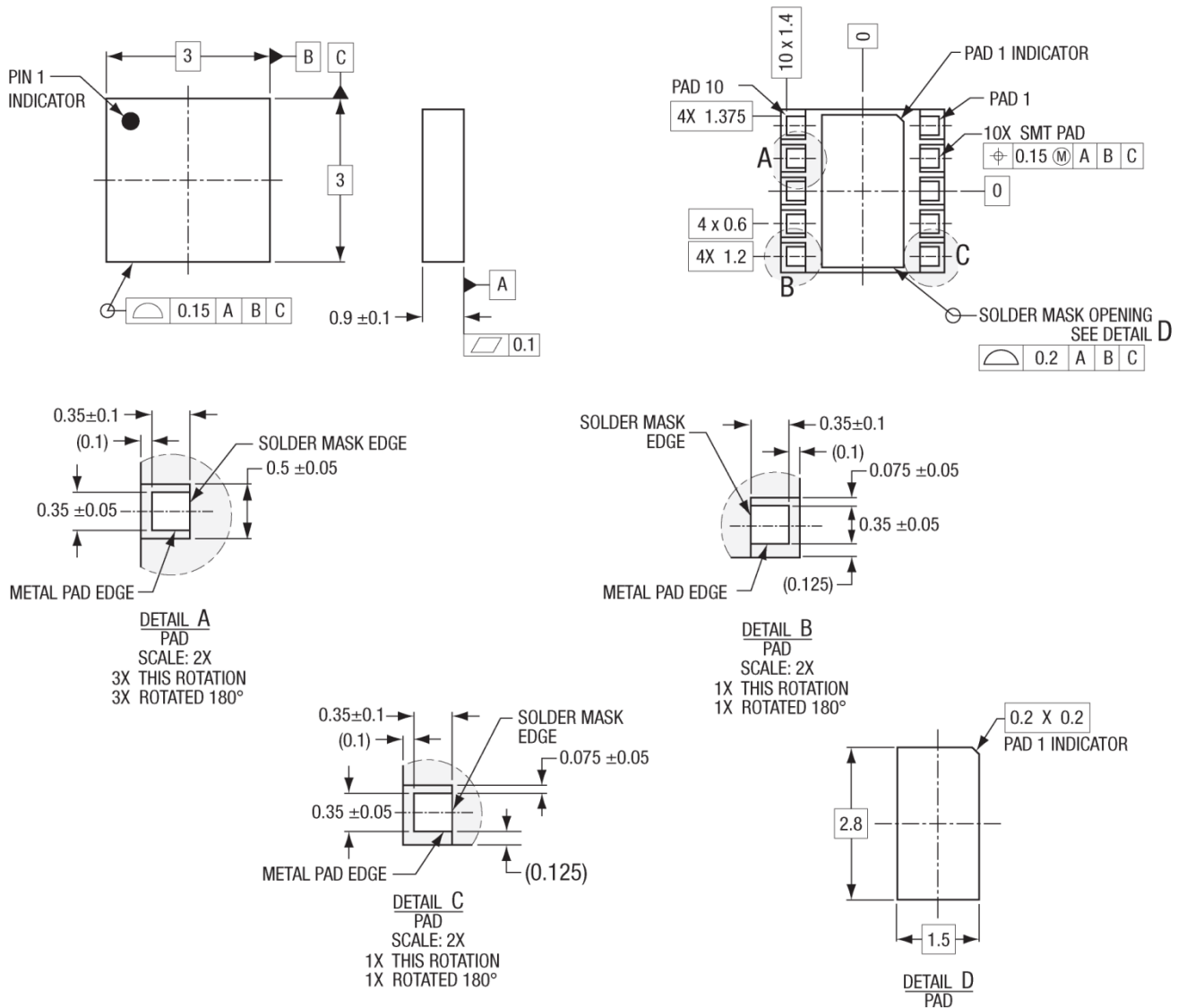

NOTES: Unless otherwise specified.

1. Dimensioning and Tolerancing in accordance with ASME Y14.5M-1994
2. All dimensions are in millimeters.

DS_D804_77761 REV 1 2/08/12
201722_006

Figure 6. Dimensional Diagram for 3 mm x 3 mm x 0.9 mm Package – SKY77768 Specific

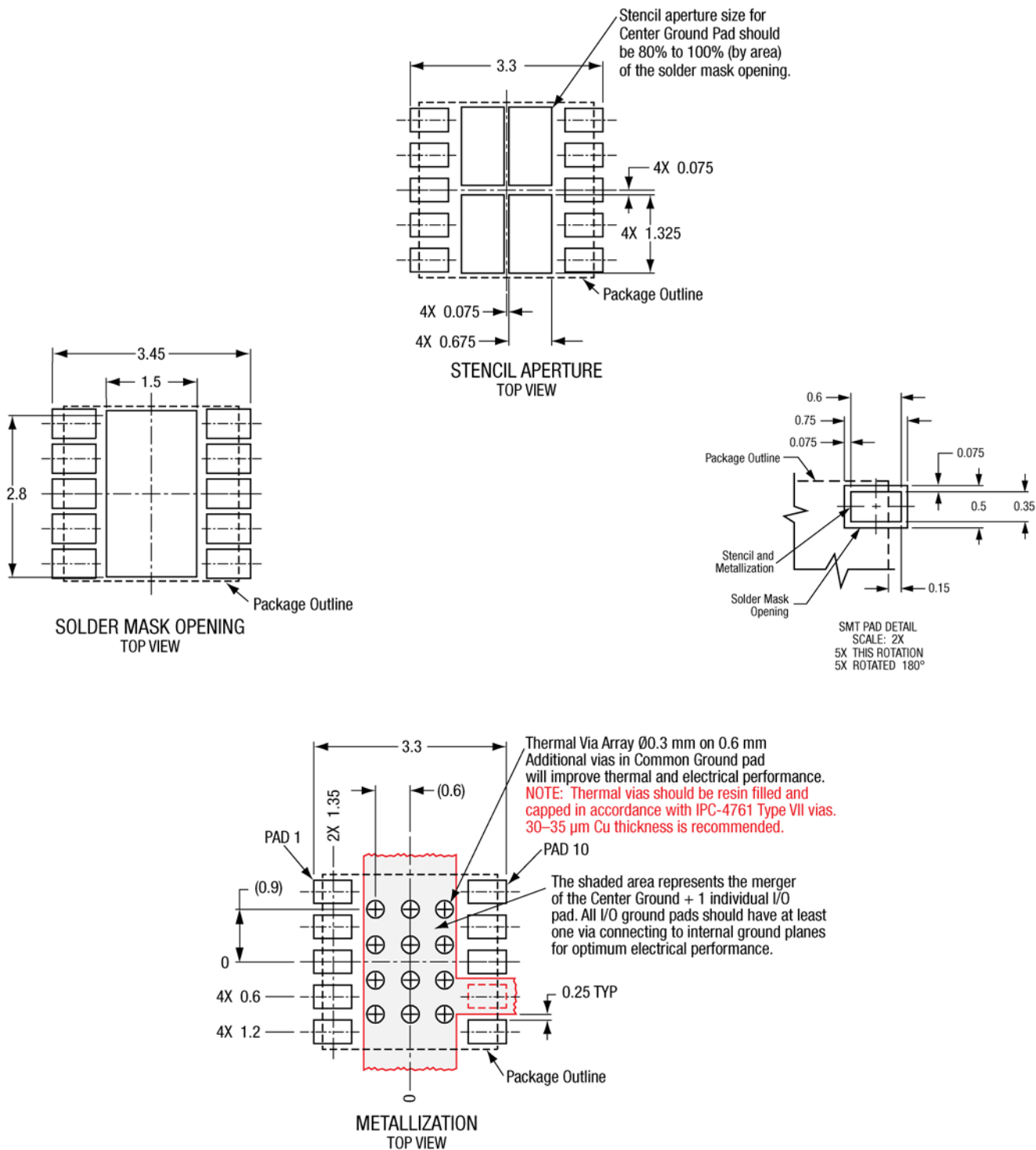

DS00109-1 REV 1 7/01/05
 201722_007

Figure 7. Phone PCB Layout Diagram – 3 mm x 3 mm, 10-Pad Package – SKY77768

Package Description

Figure 8 shows the pad functions and the pad numbering convention, which starts with pad 1 in the upper left and increments counter-clockwise around the package. Typical case markings are illustrated in Figure 9.

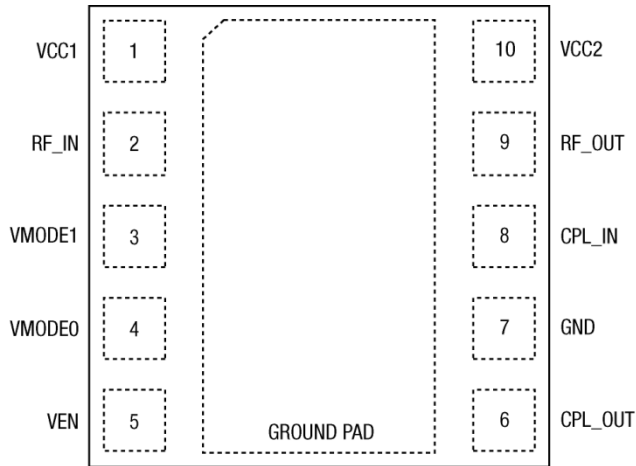

Pad layout as seen from Top View looking through the package.
GROUND PAD is package underside.

201722_006

Figure 8. SKY77768 Pad Names and Configuration (Top View)

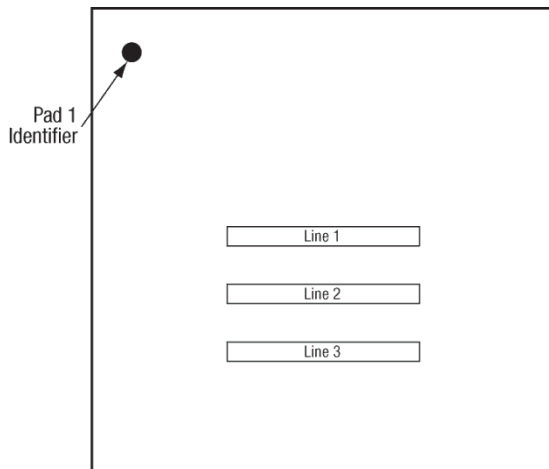

NOTE: Lines 1, 2, 3 have a maximum of 7 characters
Line 1 = Part Number and Version
Line 2 = Lot Number
Line 3 = Year-Week-Country Code (MX)

201075_007

Figure 9. Typical Case Markings

Package Handling Information

Because of its sensitivity to moisture absorption, this device package is baked and vacuum-packed prior to shipment. Instructions on the shipping container label must be followed

regarding exposure to moisture after the container seal is broken, otherwise, problems related to moisture absorption may occur when the part is subjected to high temperature during solder assembly.

The SKY77768 is capable of withstanding an MSL3/260 °C solder reflow. Care must be taken when attaching this product, whether it is done manually or in a production solder reflow environment. If the part is attached in a reflow oven, the temperature ramp rate should not exceed 3 °C per second; maximum temperature should not exceed 260 °C. If the part is manually attached, precaution should be taken to insure that the part is not subjected to temperatures exceeding 260 °C for more than 10 seconds. For details on attachment techniques, precautions, and handling procedures recommended by Skyworks, please refer to Skyworks Application Note: *PCB Design and SMT Assembly/Rework*, Document Number 101752. Additional information on standard SMT reflow profiles can also be found in the JEDEC Standard J-STD-020.

Production quantities of this product are shipped in the standard tape-and-reel format (Figure 10).

Electrostatic Discharge (ESD) Sensitivity

The SKY77768 meets class 1C JESD22-A114 Human Body Model (HBM), class IV JESD22-C101 Charged-Device Model (CDM), and class A JESD22-A115 Machine Model (MM) electrostatic discharge (ESD) sensitivity classification.

To avoid ESD damage, both latent and visible, it is very important that the product assembly and test areas follow the ESD handling precautions listed below.

- Personnel Grounding
 - Wrist Straps
 - Conductive Smocks, Gloves and Finger Cots
 - Antistatic ID Badges
- Protective Workstation
 - Dissipative Table Top
 - Protective Test Equipment (Properly Grounded)
 - Grounded Tip Soldering Irons
 - Solder Conductive Suckers
 - Static Sensors
- Facility
 - Relative Humidity Control and Air Ionizers
 - Dissipative Floors (less than 1,000 MΩ to GND)
- Protective Packaging and Transportation
 - Bags and Pouches (Faraday Shield)
 - Protective Tote Boxes (Conductive Static Shielding)
 - Protective Trays
 - Grounded Carts
 - Protective Work Order Holders

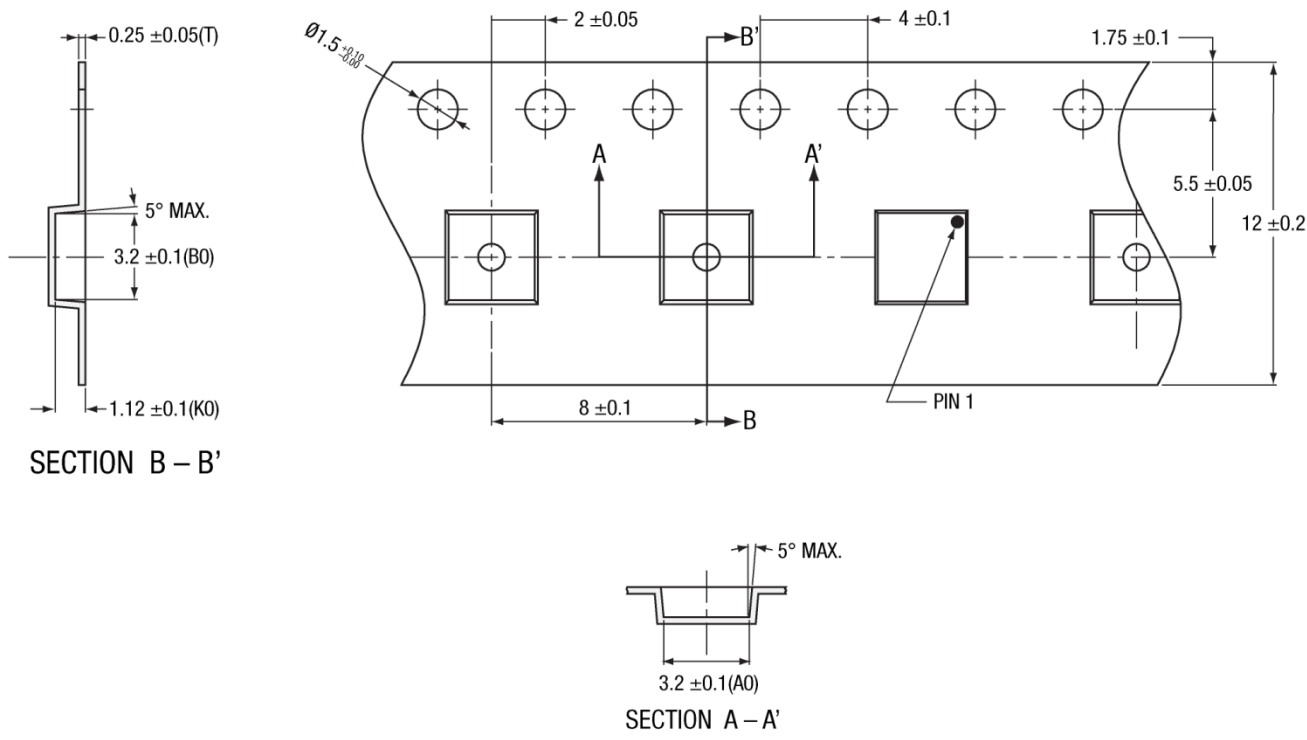

- NOTES:
1. CARRIER TAPE IS BLACK CONDUCTIVE POLYCARBONATE OR POLYSTYRENE.
 2. COVER TAPE IS TRANSPARENT AND CONDUCTIVE.
 3. ESD-SURFACE RESISTIVITY IS $\leq 1 \times 10^{10}$ OHMS/SQUARE PER EIA, JEDEC TNR SPECIFICATION.
 4. 10 SPROCKET HOLE PITCH CUMULATIVE TOLERANCE: ± 0.2 mm
 5. Ao & Bo MEASURED ON PLANE 0.3 mm ABOVE THE BOTTOM OF THE POCKET.
 6. ALL DIMENSIONS ARE IN MILLIMETERS.

CARRIER TAPE OVERMOLD MCM / RFLGA 3 x 3 x 0.75 / 0.90 mm BODY SIZE -108A
201075_008

Figure 10. Dimensional Diagram for Carrier Tape Body Size 3 mm x 3 mm x 0.75 / 0.90 mm – MCM

Ordering Information

Product Name	Order Number	Evaluation Board Part Number
SKY77768 Power Amplifier Module	SKY77768-11	EN40-D345-003

Revision History

Revision	Date	Description
A	December 20, 2011	Initial Release – Information
B	January 25, 2012	Revise: Figure 1; Table 1
C	March 9, 2012	Revise: Table 4; Figures 2, 3, 6, 7 Add: Figures 4, 5
D	September 19, 2012	Revise: Figures 2–5; Tables 2, 4; Ordering Information Table (last page)
E	October 26, 2012	Revise: Change Data Sheet status from ADVANCE to FINAL; Table 4; Ordering Information table

References

Skyworks Application Note: PCB Design and SMT Assembly/Rework, Document Number 101752.

Standard SMT Reflow Profiles: JEDEC Standard J–STD–020

Electrostatic Discharge Sensitivity (ESD) Testing: JEDEC Standard, JESD22-A114 Human Body Model (HBM)

Electrostatic Discharge Sensitivity (ESD) Testing: JEDEC Standard, JESD22-A115 Machine Model (MM)

Electrostatic Discharge Sensitivity (ESD) Testing: JEDEC Standard, JESD22-C101 Charged Device Model (CDM).

Copyright © 2011, 2012, Skyworks Solutions, Inc. All Rights Reserved.

Information in this document is provided in connection with Skyworks Solutions, Inc. (“Skyworks”) products or services. These materials, including the information contained herein, are provided by Skyworks as a service to its customers and may be used for informational purposes only by the customer. Skyworks assumes no responsibility for errors or omissions in these materials or the information contained herein. Skyworks may change its documentation, products, services, specifications or product descriptions at any time, without notice. Skyworks makes no commitment to update the materials or information and shall have no responsibility whatsoever for conflicts, incompatibilities, or other difficulties arising from any future changes.

No license, whether express, implied, by estoppel or otherwise, is granted to any intellectual property rights by this document. Skyworks assumes no liability for any materials, products or information provided hereunder, including the sale, distribution, reproduction or use of Skyworks products, information or materials, except as may be provided in Skyworks Terms and Conditions of Sale.

THE MATERIALS, PRODUCTS AND INFORMATION ARE PROVIDED “AS IS” WITHOUT WARRANTY OF ANY KIND, WHETHER EXPRESS, IMPLIED, STATUTORY, OR OTHERWISE, INCLUDING FITNESS FOR A PARTICULAR PURPOSE OR USE, MERCHANTABILITY, PERFORMANCE, QUALITY OR NON-INFRINGEMENT OF ANY INTELLECTUAL PROPERTY RIGHT; ALL SUCH WARRANTIES ARE HEREBY EXPRESSLY DISCLAIMED. SKYWORKS DOES NOT WARRANT THE ACCURACY OR COMPLETENESS OF THE INFORMATION, TEXT, GRAPHICS OR OTHER ITEMS CONTAINED WITHIN THESE MATERIALS. SKYWORKS SHALL NOT BE LIABLE FOR ANY DAMAGES, INCLUDING BUT NOT LIMITED TO ANY SPECIAL, INDIRECT, INCIDENTAL, STATUTORY, OR CONSEQUENTIAL DAMAGES, INCLUDING WITHOUT LIMITATION, LOST REVENUES OR LOST PROFITS THAT MAY RESULT FROM THE USE OF THE MATERIALS OR INFORMATION, WHETHER OR NOT THE RECIPIENT OF MATERIALS HAS BEEN ADVISED OF THE POSSIBILITY OF SUCH DAMAGE.

Skyworks products are not intended for use in medical, lifesaving or life-sustaining applications, or other equipment in which the failure of the Skyworks products could lead to personal injury, death, physical or environmental damage. Skyworks customers using or selling Skyworks products for use in such applications do so at their own risk and agree to fully indemnify Skyworks for any damages resulting from such improper use or sale.

Customers are responsible for their products and applications using Skyworks products, which may deviate from published specifications as a result of design defects, errors, or operation of products outside of published parameters or design specifications. Customers should include design and operating safeguards to minimize these and other risks. Skyworks assumes no liability for applications assistance, customer product design, or damage to any equipment resulting from the use of Skyworks products outside of stated published specifications or parameters.

Skyworks, the Skyworks symbol, “Breakthrough Simplicity,” DCR, Helios, HIP3, Innovation to Go, Intera, iPAC, LIPA, Polar Loop, and System Smart are trademarks or registered trademarks of Skyworks Solutions, Inc., in the United States and other countries. Third-party brands and names are for identification purposes only, and are the property of their respective owners. Additional information, including relevant terms and conditions, posted at www.skyworksinc.com, are incorporated by reference.