



DALC112S1

Application Specific Discretes
A.S.D.TM

LOW CAPACITANCE DIODE ARRAY FOR ESD PROTECTION

MAIN APPLICATIONS

Where ESD protection for high speed datalines is required :

- LAN / WAN equipment
- Computer I/O
- Graphic video port
- Set top box I/O

DESCRIPTION

ARRAY of 12 diodes configured by cells of 2 diodes, each cell being used to protect signal line from transient overvoltages by clamping action.

Its very low capacitance allows to protect fast signals with no distortion. It is particularly suited for the protection of graphic video ports.

FEATURES

- ARRAY OF 12 DIODES FOR ESD PROTECTION.
- PEAK REVERSE VOLTAGE $V_{RRM} = 18V$ PER DIODE.
- VERY LOW CAPACITANCE PER DIODE : $C < 5pF$.
- VERY LOW LEAKAGE CURRENT : $I_R < 2 \mu A$.

COMPLIES WITH THE FOLLOWING STANDARDS :

IEC 1000-4-2 level 3 8 kV (air discharge)
 6 kV (contact discharge)

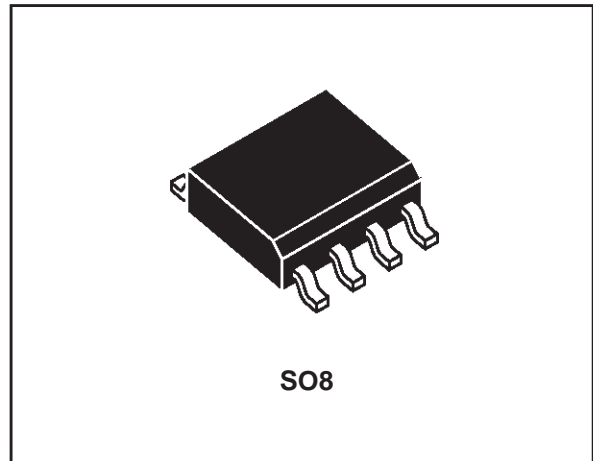

FUNCTIONAL DIAGRAM

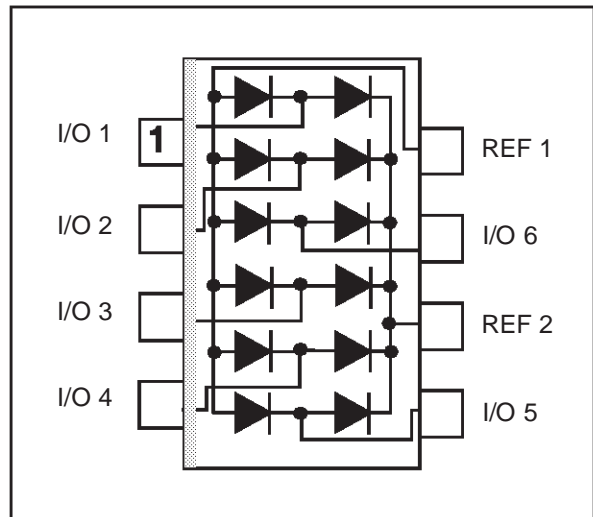

DALC112S1

TYPICAL APPLICATION

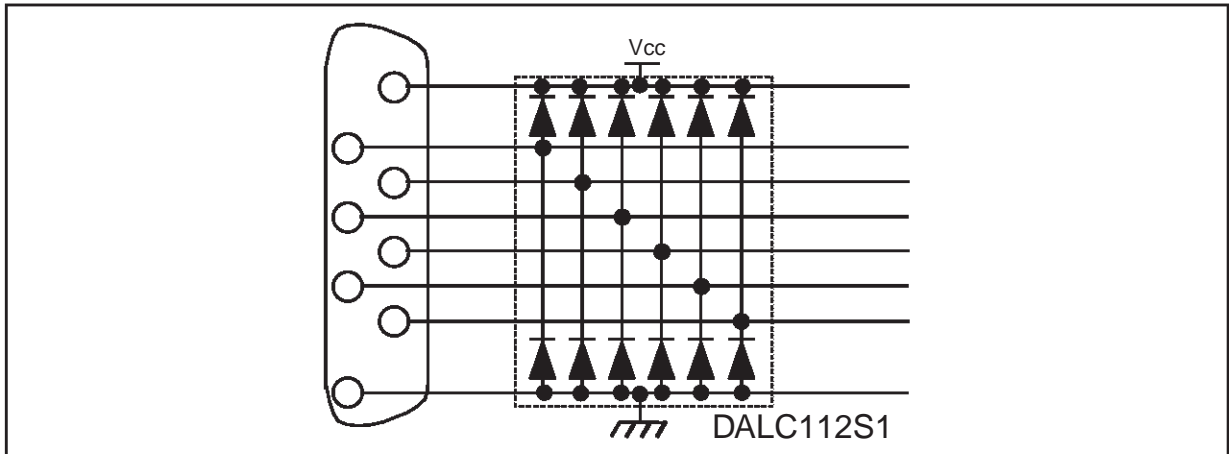

ABSOLUTE MAXIMUM RATINGS ($T_{amb} = 25^{\circ}\text{C}$).

Symbol	Parameter	Value	Unit
V_{RRM}	Peak reverse voltage per diode	18	V
T_{stg} T_j	Storage temperature range Maximum junction temperature	-55 to + 150 150	$^{\circ}\text{C}$ $^{\circ}\text{C}$

ELECTRICAL CHARACTERISTICS ($T_{amb} = 25^{\circ}\text{C}$).

Symbol	Parameter	Typ.	Max.	Unit
V_F	Forward voltage $I_F = 50 \text{ mA}$		1.3	V
I_R	Reverse leakage current per diode $V_R = 15 \text{ V}$		2	μA
C	Input capacitance between Line and GND $V_{cc} = 5 \text{ V}$, $V_{RMS} = 30 \text{ mV}$, $F = 1 \text{ MHz}$ (see figure 1 below)	7		pF

Fig 1 : Input capacitance measurement

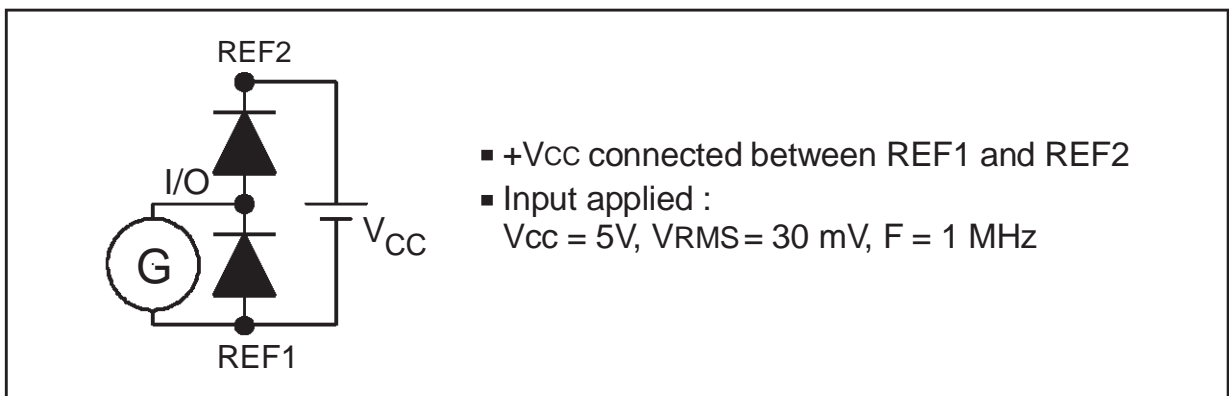

ORDER CODE

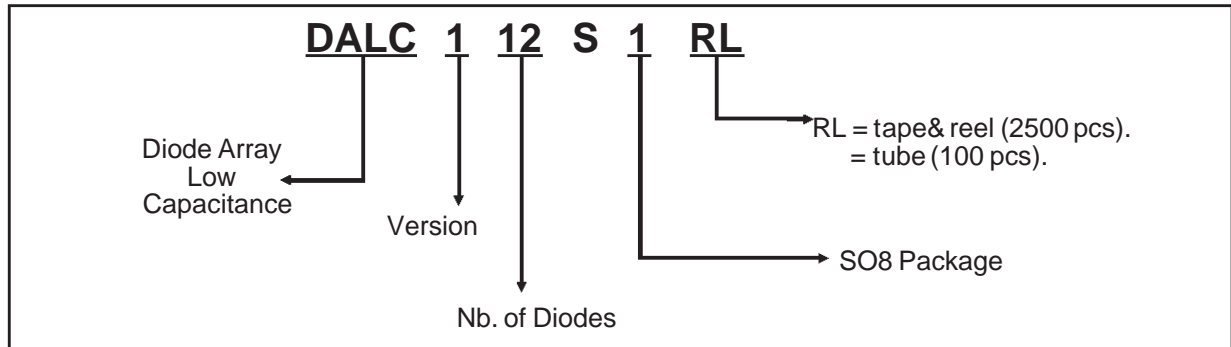

MARKING

Type	Marking	Order Code	Packaging (Base Qty)
DALC112S1	DALC12	DALC112S1 DALC112S1RL	tube (100) tape & reel (2500)

PACKAGE MECHANICAL DATA

SO8 (Plastic)

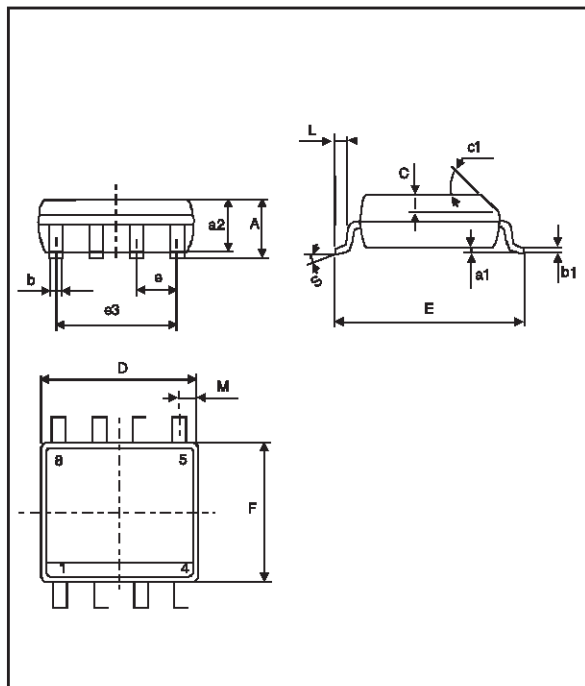

REF.	DIMENSIONS					
	Millimetres			Inches		
	Min.	Typ.	Max.	Min.	Typ.	Max.
A			1.75			0.069
a1	0.1		0.25	0.004		0.010
a2			1.65			0.065
b	0.35		0.48	0.014		0.019
b1	0.19		0.25	0.007		0.010
C		0.50			0.020	
c1	45° (typ)					
D	4.8		5.0	0.189		0.197
E	5.8		6.2	0.228		0.244
e		1.27			0.050	
e3		3.81			0.150	
F	3.8		4.0	0.15		0.157
L	0.4		1.27	0.016		0.050
M			0.6			0.024
S	8° (max)					

PACKAGING: Preferred packaging is tape and reel.

Information furnished is believed to be accurate and reliable. However, STMicroelectronics assumes no responsibility for the consequences of use of such information nor for any infringement of patents or other rights of third parties which may result from its use. No license is granted by implication or otherwise under any patent or patent rights of STMicroelectronics. Specifications mentioned in this publication are subject to change without notice. This publication supersedes and replaces all information previously supplied. STMicroelectronics products are not authorized for use as critical components in life support devices or systems without express written approval of STMicroelectronics.

© 1998 STMicroelectronics - Printed in Italy - All rights reserved.

STMicroelectronics GROUP OF COMPANIES

Australia - Brazil - Canada - China - France - Germany - Italy - Japan - Korea - Malaysia - Malta - Mexico - Morocco - The Netherlands - Singapore - Spain - Sweden - Switzerland - Taiwan - Thailand - United Kingdom - U.S.A.

