

Highly accurate, temperature-compensated serial real-time clock (RTC) with embedded crystal

Data brief

Features

- Embedded high-stability 32 KHz DTCXO
- Temperature-compensated serial real-time clock
 - ± 5.0 ppm max from -40 to 85 °C
 - ± 3.8 ppm max from 0 to 50 °C
- Supply voltage
 - Clock operating & timekeeping: 1.6 to 5.5 V
 - I²C interface operating: 1.8 to 5.5 V
 - Temperature compensation: 2.2 to 5.5 V
- 0.8 μ A typical current at 3.0 V supply voltage
- 400 kHz I²C interface
- Time-of-day alarm (with interrupt)
- Fixed-cycle timer interrupt function
- Time update interrupt function
- Programmable frequency output
 - FOUT = 1 Hz, 1 KHz and 32 KHz
- Registers for seconds, minutes, hours, day-of-week, date (day of month), month and year with automatic leap year compensation
- Programmable temperature compensation intervals (0.5 s, 2 s default, 10 s, 30 s)

Applications

- Power meters
- Industrial applications

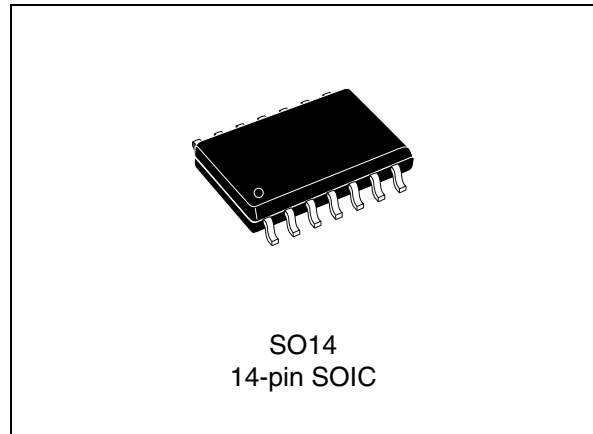

Description

The M41TC8025 is a serial I²C real-time clock (RTC) incorporating temperature compensation to maintain accurate timekeeping over the industrial temperature range of -40 to $+85$ °C. In addition to providing date and time (seconds, minutes, hours, day-of-week, date (day of month), month and year), the device also provides an alarm function, fixed-cycle timer, time update interrupt and programmable frequency outputs (1 Hz, 1 KHz and 32 KHz).

The M41TC8025 is provided in a 200 mil, 14 -pin SOIC package.

Table 1. Device summary

| Order code | Accuracy | Package |
|----------------|--|---------|
| M41TC8025AMC6F | ± 5.0 ppm (-40 to 85 °C) ± 3.8 ppm (0 to 50 °C) | SO14 |

1 Device overview

Figure 1. Logic diagram

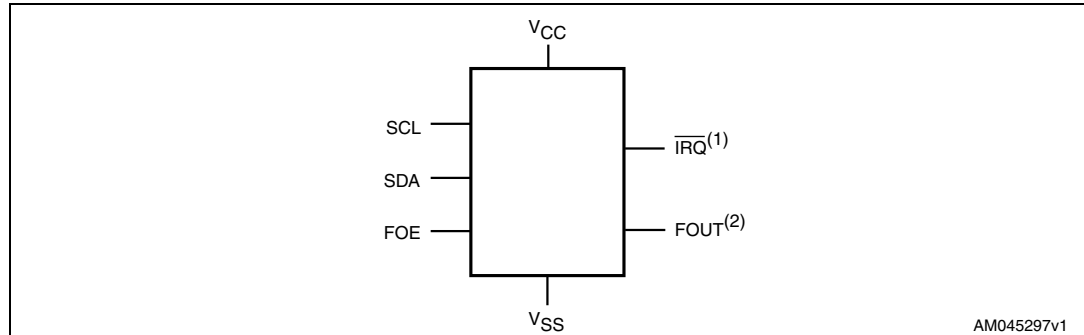

- 1. \overline{IRQ} is an open-drain output
- 2. FOUT is a CMOS output

Figure 2. Pinout

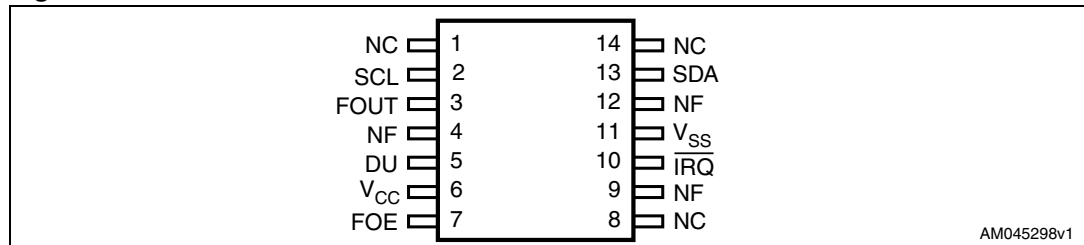
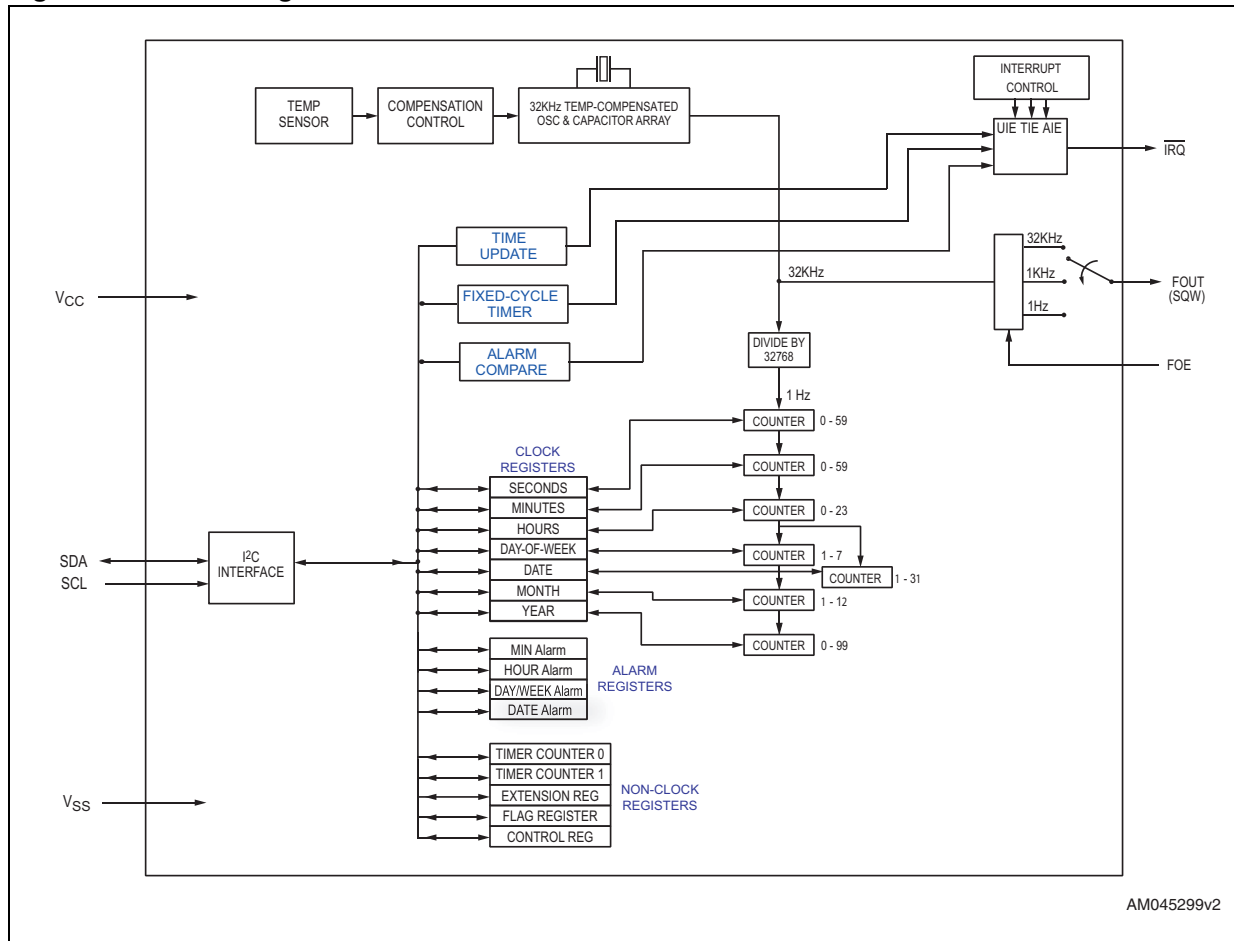

Table 2. Pin description

| Pin | Name | Description |
|-----|------------------|--|
| 1 | NC | No connect. The NC pin can be connected to V_{CC} , GND or left floating. |
| 2 | SCL | Serial clock input |
| 3 | FOUT | Programmable frequency output (CMOS). The FOUT pin is Hi-Z if FOE is low. |
| 4 | NF | No function. The NF pin can be connected to V_{CC} , GND or left floating. |
| 5 | DU | Do not use externally. The DU pin must be left floating. |
| 6 | V_{CC} | Power supply |
| 7 | FOE | Frequency output enable, controls the frequency output on FOUT pin |
| 8 | NC | No connect. The NC pin can be connected to V_{CC} , GND or left floating. |
| 9 | NF | No function. The NF pin can be connected to V_{CC} , GND or left floating. |
| 10 | \overline{IRQ} | Interrupt output (open drain) |
| 11 | V_{SS} | Ground supply |
| 12 | NF | No function. The NF pin can be connected to V_{CC} , GND or left floating. |
| 13 | SDA | Serial data input/output |
| 14 | NC | No connect. The NC pin can be connected to V_{CC} , GND or left floating. |

Note: Be sure to connect a 0.1 μF to 1 μF bypass capacitor between V_{CC} and V_{SS} .

Figure 3. Block diagram



AM045299v2

Figure 4. Hardware hookup

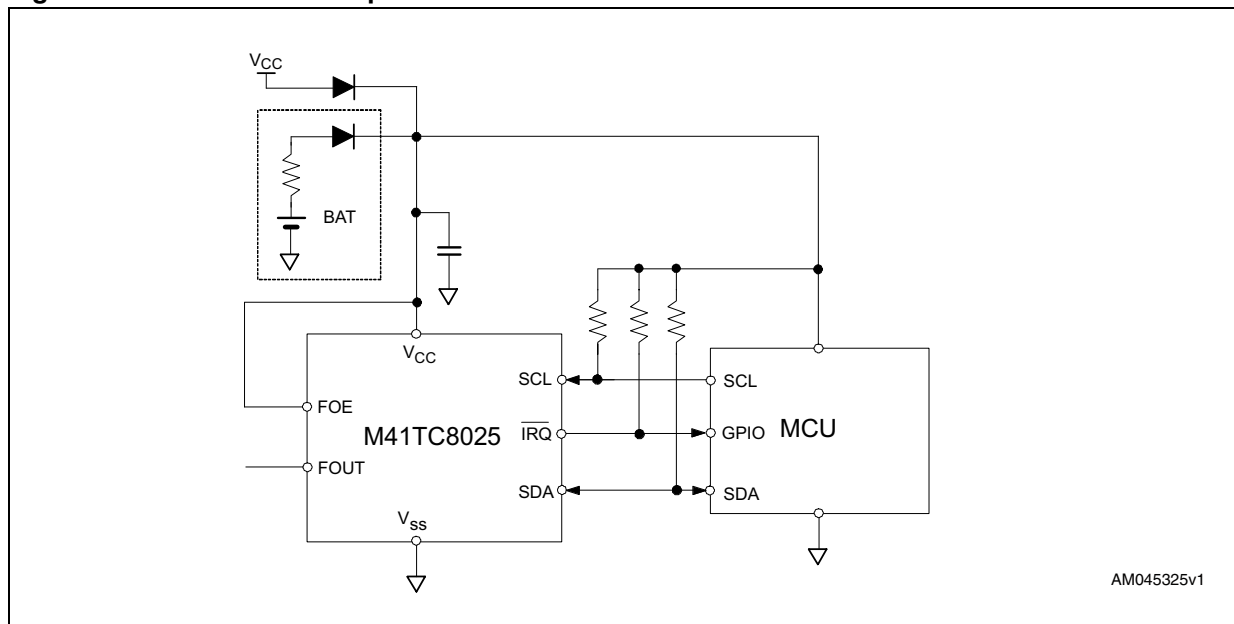

AM045325v1

2 Package mechanical data

In order to meet environmental requirements, ST offers these devices in different grades of ECOPACK® packages, depending on their level of environmental compliance. ECOPACK® specifications, grade definitions and product status are available at: www.st.com. ECOPACK® is an ST trademark.

Figure 5. SO14 - 14-lead small outline (200 mils body width) package mechanical drawing

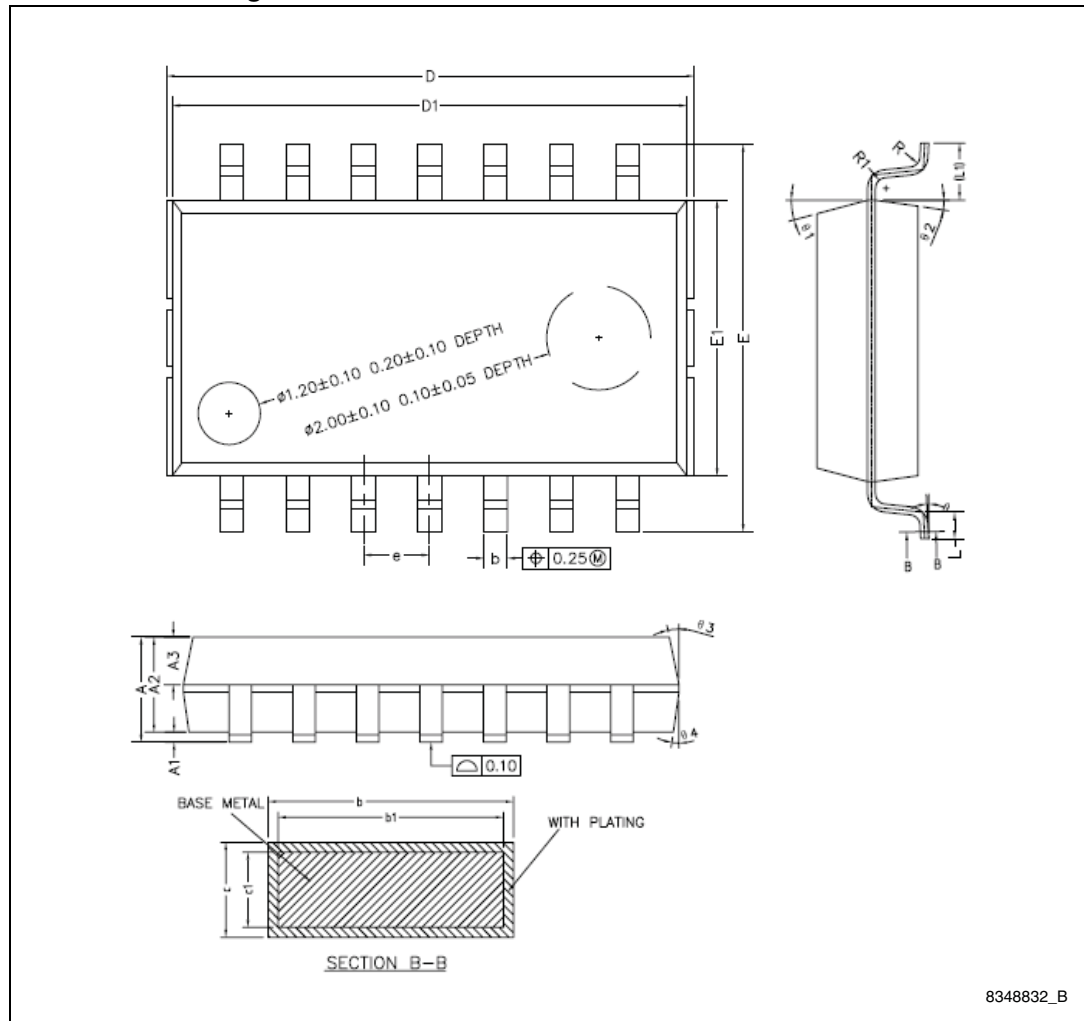

Table 3. SO14 - 14-lead small outline (200 mils body width) package mechanical data

| Symbol | mm | | | in | | |
|------------------|-----------|-------|-------|------------|-------|-------|
| | Min | Typ | Max | Min | Typ | Max |
| A | - | - | 2.25 | - | - | 0.089 |
| A1 | 0.15 | 0.20 | 0.25 | 0.006 | 0.008 | 0.010 |
| A2 | 1.80 | 1.90 | 2.00 | 0.071 | 0.075 | 0.079 |
| A3 | 0.85 | 0.95 | 1.05 | 0.033 | 0.037 | 0.041 |
| b | 0.41 | - | 0.54 | 0.016 | - | 0.021 |
| b1 | 0.40 | 0.45 | 0.50 | 0.016 | 0.018 | 0.020 |
| c | 0.14 | - | 0.21 | 0.006 | - | 0.008 |
| c1 | 0.13 | 0.15 | 0.17 | 0.005 | 0.006 | 0.007 |
| D1 | 9.80 | 9.90 | 10.00 | 0.386 | 0.390 | 0.394 |
| D ⁽¹⁾ | 10.05 | 10.15 | 10.25 | 0.396 | 0.400 | 0.404 |
| E | 7.30 | 7.45 | 7.60 | 0.287 | 0.293 | 0.299 |
| E1 | 5.20 | 5.30 | 5.40 | 0.205 | 0.209 | 0.213 |
| e | 1.27 | | | 0.050 | | |
| L | 0.30 | 0.50 | 0.70 | 0.012 | 0.020 | 0.028 |
| L1 | 1.07 ref. | | | 0.042 ref. | | |
| R | 0.07 | - | - | 0.003 | - | - |
| R1 | 0.07 | - | - | 0.003 | - | - |
| θ1 | 0° | - | 8° | 0° | - | 8° |
| θ2 | 13° | 15° | 17° | 13° | 15° | 17° |
| θ3 | 6° | 8° | 10° | 6° | 8° | 10° |
| θ4 | 9.5° | 11.5° | 13.5° | 9.5° | 11.5° | 13.5° |
| θ5 | 6° | 8° | 10° | 6° | 8° | 10° |

1. Dimension "D" includes mold flash.

3 Part numbering

Table 4. Ordering information scheme

| Example: | M41TC | 8025 | A | MC | 6 | F |
|--------------------------|-------|------|--|-----------|---------------------|-----------------------------------|
| Device family | M41TC | | | | | |
| Device type | | 8025 | | | | |
| Accuracy | | | A = ±5.0 ppm (-40 to 85 °C) ±3.8 ppm (0 to 50 °C) | | | |
| Package | | | | MC = SO14 | | |
| Temperature range | | | | | 6 = -40 °C to 85 °C | |
| Shipping method | | | | | | F = ECOPACK® package, tape & reel |

For other options, or for more information on any aspect of this device, please contact the ST sales office nearest you.

4 Revision history

Table 5. Document revision history

| Date | Revision | Changes |
|-------------|----------|---|
| 21-Aug-2012 | 1 | Initial release. |
| 21-Sep-2012 | 2 | Modified title of document; updated Figure 3: Block diagram . |

Please Read Carefully:

Information in this document is provided solely in connection with ST products. STMicroelectronics NV and its subsidiaries ("ST") reserve the right to make changes, corrections, modifications or improvements, to this document, and the products and services described herein at any time, without notice.

All ST products are sold pursuant to ST's terms and conditions of sale.

Purchasers are solely responsible for the choice, selection and use of the ST products and services described herein, and ST assumes no liability whatsoever relating to the choice, selection or use of the ST products and services described herein.

No license, express or implied, by estoppel or otherwise, to any intellectual property rights is granted under this document. If any part of this document refers to any third party products or services it shall not be deemed a license grant by ST for the use of such third party products or services, or any intellectual property contained therein or considered as a warranty covering the use in any manner whatsoever of such third party products or services or any intellectual property contained therein.

UNLESS OTHERWISE SET FORTH IN ST'S TERMS AND CONDITIONS OF SALE ST DISCLAIMS ANY EXPRESS OR IMPLIED WARRANTY WITH RESPECT TO THE USE AND/OR SALE OF ST PRODUCTS INCLUDING WITHOUT LIMITATION IMPLIED WARRANTIES OF MERCHANTABILITY, FITNESS FOR A PARTICULAR PURPOSE (AND THEIR EQUIVALENTS UNDER THE LAWS OF ANY JURISDICTION), OR INFRINGEMENT OF ANY PATENT, COPYRIGHT OR OTHER INTELLECTUAL PROPERTY RIGHT.

UNLESS EXPRESSLY APPROVED IN WRITING BY TWO AUTHORIZED ST REPRESENTATIVES, ST PRODUCTS ARE NOT RECOMMENDED, AUTHORIZED OR WARRANTED FOR USE IN MILITARY, AIR CRAFT, SPACE, LIFE SAVING, OR LIFE SUSTAINING APPLICATIONS, NOR IN PRODUCTS OR SYSTEMS WHERE FAILURE OR MALFUNCTION MAY RESULT IN PERSONAL INJURY, DEATH, OR SEVERE PROPERTY OR ENVIRONMENTAL DAMAGE. ST PRODUCTS WHICH ARE NOT SPECIFIED AS "AUTOMOTIVE GRADE" MAY ONLY BE USED IN AUTOMOTIVE APPLICATIONS AT USER'S OWN RISK.

Resale of ST products with provisions different from the statements and/or technical features set forth in this document shall immediately void any warranty granted by ST for the ST product or service described herein and shall not create or extend in any manner whatsoever, any liability of ST.

ST and the ST logo are trademarks or registered trademarks of ST in various countries.

Information in this document supersedes and replaces all information previously supplied.

The ST logo is a registered trademark of STMicroelectronics. All other names are the property of their respective owners.

© 2012 STMicroelectronics - All rights reserved

STMicroelectronics group of companies

Australia - Belgium - Brazil - Canada - China - Czech Republic - Finland - France - Germany - Hong Kong - India - Israel - Italy - Japan - Malaysia - Malta - Morocco - Philippines - Singapore - Spain - Sweden - Switzerland - United Kingdom - United States of America

www.st.com