



STMUX1000L

GIGABIT LAN ANALOG SWITCH 16-BIT TO 8-BIT MULTIPLEXER

- LOW R_{ON} : 5.5 Ω TYPICAL
- V_{CC} OPERATING RANGE: 3.0 TO 3.6 V
- LOW CURRENT CONSUMPTION: 20 μ A
- ESD HBM MODEL: > 2 KV
- CHANNEL ON CAPACITANCE: 7.5 pF TYPICAL
- SWITCHING TIME SPEED: 9 ns
- NEAR TO ZERO PROPAGATION DELAY: 250 ps
- VERY LOW CROSS TALK: -40 dB AT 250MHz
- BIT TO BIT SKEW: 200 ps
- > 450 MHZ -3db TYPICAL BANDWIDTH
- THREE SWITCH S.P.D.T FOR LED SUPPORTING
- PACKAGE: QFN56
- Pb FREE

DESCRIPTION

The STMUX1000L is a 16 to 8 Bit multiplexer/demultiplexer low R_{ON} bidirectional LAN Switch designed for various standard, such as 10/100/1000 Ethernet.



Table 1: Order Codes

PACKAGE	T & R
QFN	STMUX1000LQTR

It is designed for very low Cross Talk, low bit to bit skew and low I/O capacitance.

The differential signal from the Gigabit Ethernet Transceiver is multiplexed in one of two selected output while the unselected switch go to Hi-Z status.

The device integrates three 16Ω switches, S.P.D.T. (Single Pole Dual Throw Channel), for LED supporting.

Figure 1: Pin Connection (Top Through View)

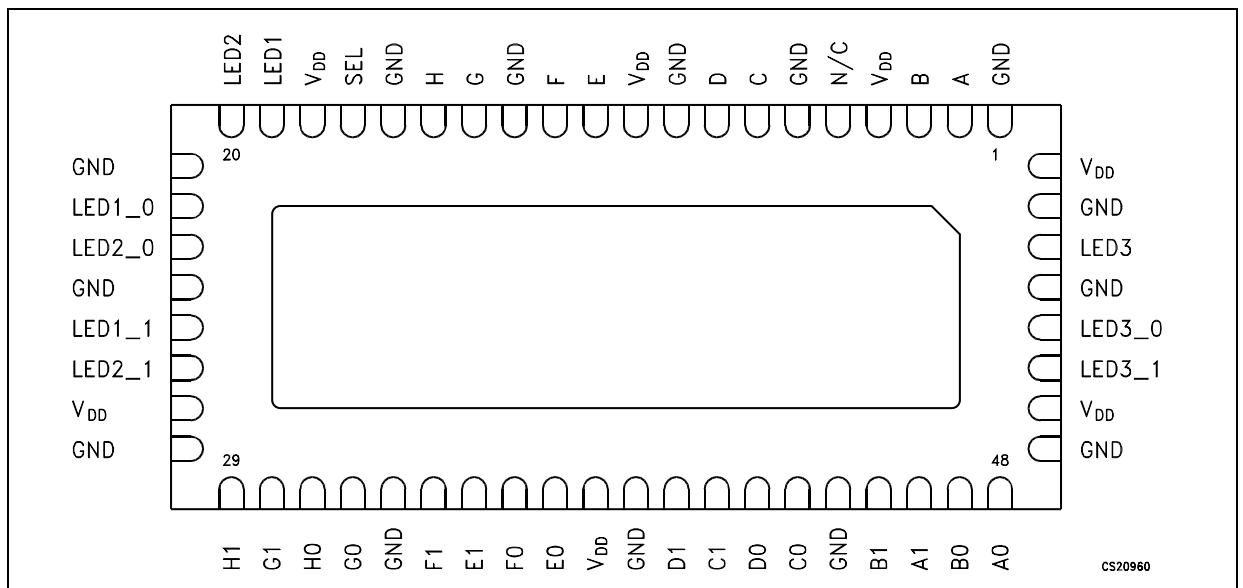

Figure 2: Input Equivalent Circuit

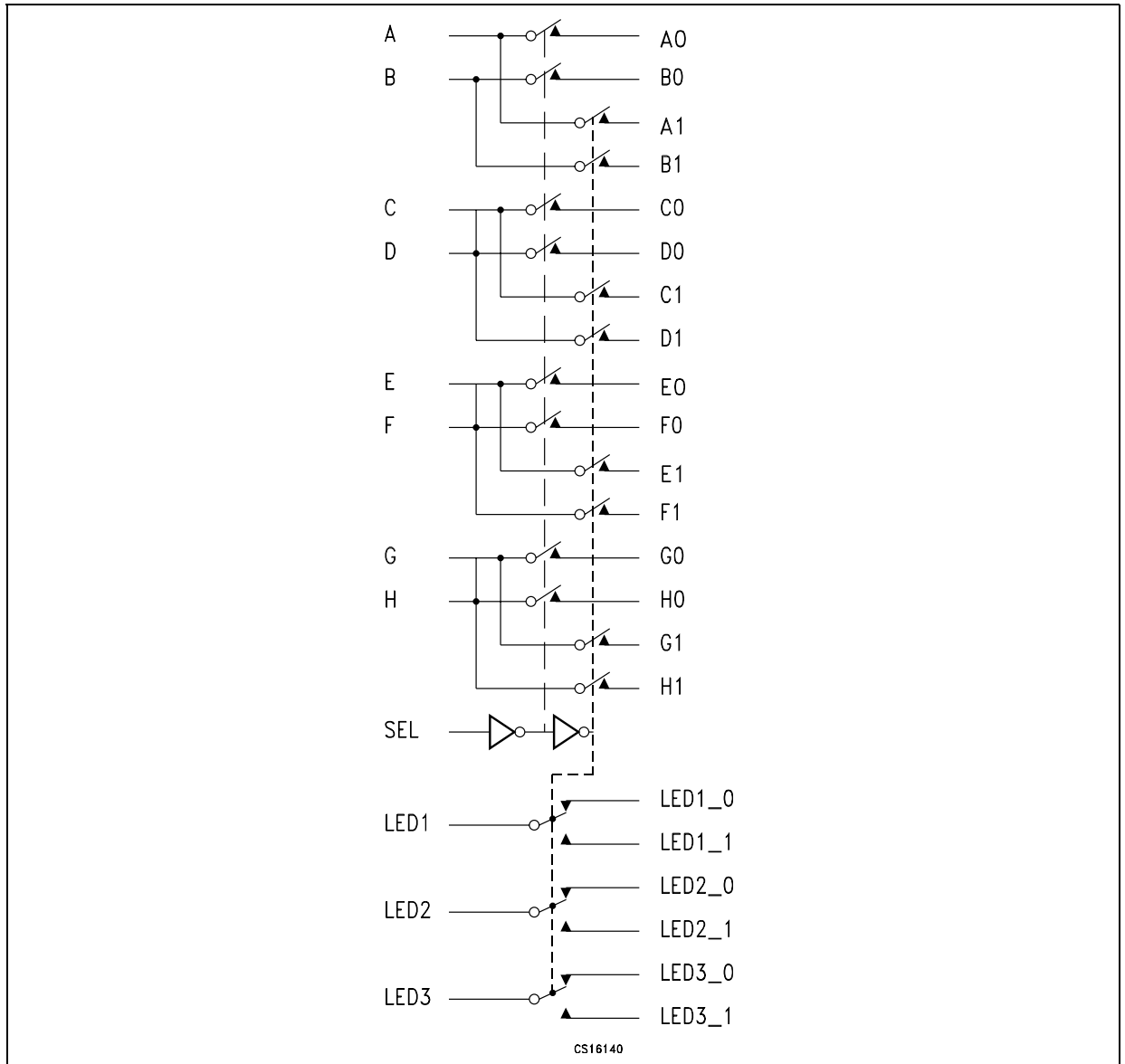

Table 2: Pin Description

PIN N°	SYMBOL	NAME AND FUNCTION
2, 3, 7, 8, 11, 12, 14, 15	A, B, C, D, E, F, G, H	8 Bit Bus
48, 47, 43, 42, 37, 36, 32, 31	A0, B0, C0, D0, E0, F0, G0, H0	8 Bit Multiplexed to Bus 0
46, 45, 41, 40, 35, 34, 30, 29	A1, B1, C1, D1, E1, F1, G1, H1	8 Bit Multiplexed to Bus 1
5	N/C	Not Connected
17	SEL	BUS and LED Switch Selection
19, 20, 54	LED1, LED2, LED3	LED Switch Input
22, 23, 25, 26, 51, 52	LED1_0, LED2_0, LED1_1, LED2_1, LED3_0, LED3_1	LED Switch Output
4, 10, 18, 27, 38, 50, 56	V _{DD}	Supply Voltage
1, 6, 9, 13, 16, 21, 24, 28, 33, 39, 44, 49, 53, 55	GND	Ground

Table 3: Lan Switch Function Table

SE	FUNCTION
L	8 Bit Bus to 8 Bit Multiplexed Bus 0
H	8 Bit Bus to 8 Bit Multiplexed Bus 1

Table 4: Led Switch Function Table

SE	FUNCTION
L	Led Switch Input connected to Led Switch Output X_0
H	Led Switch Input connected to Led Switch Output X_1

Table 5: Absolute Maximum Ratings

Symbol	Parameter	Value	Unit
V_{CC}	Supply Voltage to Ground	-0.5 to 4	V
V_I	DC Input Voltage	-0.5 to 4	V
V_{IC}	DC Control Input Voltage	-0.5 to 4	V
I_O	DC Output Current (*)	120	mA
P_D	Power Dissipation	0.5	W
T_{stg}	Storage Temperature	-65 to 150	°C
T_L	Lead Temperature (10 sec)	300	°C

Absolute Maximum Ratings are those values beyond which damage to the device may occur. Functional operation under these conditions is not implied.

(*) If not exceed the max limit of P_D .

Table 6: DC Electrical Characteristics For Gigabit Ethernet LAN8/16MUX/DEMUX

($T_A = -40$ to 85°C , $V_{CC} = 3.3\text{V} \pm 10\%$)

Symbol	Parameter	Test Conditions	Min.	Typ.	Max.	Unit
V_{IH}	Voltage Input High	High Level Guaranteed	2			V
V_{IL}	Voltage Input Low	Low Level Guaranteed	-0.5		0.8	V
V_{IK}	Clamp Diode Voltage	$V_{CC} = 3.6\text{V}$, $I_{IN} = -18\text{mA}$		-0.8	-1.2	V
I_{IH}	Input High Current	$V_{CC} = 3.6\text{V}$, $V_{IN} = V_{CC}$			± 5	μA
I_{IL}	Input Low Current	$V_{CC} = 3.6\text{V}$, $V_{IN} = \text{GND}$			± 5	μA
I_{OFF}	Power Down Leakage Current	$V_{CC} = 0\text{V}$, A to H $V = 0\text{V}$, A0 to H0 and A1 to H1 $\leq 3.6\text{V}$			± 5	μA
R_{ON}	Switch ON Resistance (1)	$V_{CC} = 3.0\text{V}$, $V_{IN} = 1.5$ to V_{CC} $I_{IN} = -40\text{mA}$		5.5	7.5	Ω
R_{FLAT}	ON Resistance FLATNESS (1, 2)	$V_{CC} = 3.0\text{V}$, $V_{IN} @ 1.5$ and V_{CC} $I_{IN} = -40\text{mA}$		0.8		Ω
ΔR_{ON}	ON Resistance Match between channel $\Delta R_{ON} = R_{ONMAX} - R_{ONMIN}$ (1,3)	$V_{CC} = 3.0\text{V}$, $V_{IN} = 1.5$ to V_{CC} $I_{IN} = -40\text{mA}$		0.5	1	Ω

Note 1: Measured by voltage drop between Channels @ indicated current through the switch. On-Resistance is determined by the lower the voltage on the two.

Note 2: Flatness is defined as the difference the R_{ONMAX} and R_{ONMIN} of On-Resistance over the specified range condition.

Note 3: ΔR_{ON} measured @ same V_{CC} , temperature and voltage level.

Table 7: DC Electrical Characteristics For 10/100 Ethernet LAN8/16MUX/DEMUX(T_A = -40 to 85°C, V_{CC} = 3.3V ±10%)

Symbol	Parameter	Test Conditions	Min.	Typ.	Max.	Unit
V _{IH}	Voltage Input High	High Level Guaranteed	2			V
V _{IL}	Voltage Input Low	Low Level Guaranteed	-0.5		0.8	V
V _{IK}	Clamp Diode Voltage	V _{CC} = 3.6V, I _{IN} = -18mA		-0.7	-1.2	V
I _{IH}	Input High Current	V _{CC} = 3.6V, V _{IN} = V _{CC}			±5	μA
I _{IL}	Input Low Current	V _{CC} = 3.6V, V _{IN} = GND			±5	μA
I _{OFF}	Power Down Leakage Current	V _{CC} = 0V, A to H V = 0V, A0 to H0 and A1 to H1 ≤ 3.6V			±5	μA
R _{ON}	Switch ON Resistance (1)	V _{CC} = 3.0 V, V _{IN} = 1.25 to V _{CC} I _{IN} = -40mA		5.5	7.5	Ω
R _{FLAT}	ON Resistance FLATNESS (1, 2)	V _{CC} = 3.0 V, V _{IN} @ 1.25 and V _{CC} I _{IN} = -40mA		0.9		Ω
ΔR _{ON}	ON Resistance Match between channel ΔR _{ON} = R _{ONMAX} -R _{ONMIN} (1, 3)	V _{CC} = 3.0 V, V _{IN} = 1.25 to V _{CC} I _{IN} = -40mA		0.5	1	Ω

Note 1: Measured by voltage drop between Channels @ indicated current through the switch. On-Resistance is determined by the lower the voltage on the two.

Note 2: Flatness is defined as the difference the R_{ONMAX} and R_{ONMIN} of On-Resistance over the specified range condition.

Note 3: ΔR_{ON} measured @ same V_{CC}, temperature and voltage level.

Table 8: Led Switches DC Electrical Characteristics(T_A = -40 to 85°C, V_{CC} = 3.3V ±10%)

Symbol	Parameter	Test Conditions	Min.	Typ.	Max.	Unit
V _{IH}	Voltage Input High	High Level Guaranteed	2			V
V _{IL}	Voltage Input Low	Low Level Guaranteed	-0.5		0.8	V
V _{IK}	Clamp Diode Voltage	V _{CC} = 3.6V, I _{IN} = -18mA		-0.7	-1.2	V
I _{IH}	Input High Current	V _{CC} = 3.6V, V _{IN} = V _{CC}			±5	μA
I _{IL}	Input Low Current	V _{CC} = 3.6V, V _{IN} = GND			±5	μA
R _{ON}	Switch ON Resistance (1)	V _{CC} = 3.0 V, V _{IN} = 1.25 to V _{CC} I _{IN} = -40mA		16	25	Ω
R _{FLAT}	ON Resistance FLATNESS (1, 2)	V _{CC} = 3.0 V, V _{IN} @ 1.25 and V _{CC} I _{IN} = -40mA		8		Ω
ΔR _{ON}	ON Resistance Match between channel ΔR _{ON} = R _{ONMAX} -R _{ONMIN} (1, 3)	V _{CC} = 3.0 V, V _{IN} = 1.25 to V _{CC} I _{IN} = -40mA		1	2	Ω

Note 1: Measured by voltage drop between Channels @ indicated current through the switch. On-Resistance is determined by the lower the voltage on the two.

Note 2: Flatness is defined as the difference the R_{ONMAX} and R_{ONMIN} of On-Resistance over the specified range condition.

Note 3: ΔR_{ON} measured @ same V_{CC}, temperature and voltage level.

Table 9: Capacitance Lan 8/16 MUX/DEMUX ($T_A = 25^\circ\text{C}$, $f = 1\text{ MHz}$)

Symbol	Parameter	Test Conditions	Min.	Typ.	Max.	Unit
C_{IN}	Input Capacitance (Note 4)	$V_{IN} = 0\text{ V}$		2	3	pF
C_{OFF}	Port x0 to Port x1, Switch Off (Note 4)	$V_{IN} = 0\text{ V}$		4	6	pF
C_{ON}	Capacitance Switch On (x to x0 or x to x1) (Note 4)	$V_{IN} = 0\text{ V}$		7.5	11	pF

Note 4: x = A to H, x0 = A0 to H0, x1 = A1 to H1.

Table 10: Capacitance Led Switches ($T_A = 25^\circ\text{C}$, $f = 1\text{ MHz}$)

Symbol	Parameter	Test Conditions	Min.	Typ.	Max.	Unit
C_{IN}	Input Capacitance	$V_{IN} = 0\text{ V}$			10	pF
C_{OFF}	Port x0 to Port x1, Switch Off	$V_{IN} = 0\text{ V}$		4	10	pF
C_{ON}	Capacitance Switch On	$V_{IN} = 0\text{ V}$		11	20	pF

Table 11: Power Supply Characteristics ($T_A = -40\text{ to }85^\circ\text{C}$)

Symbol	Parameter	Test Conditions	Min.	Typ.	Max.	Unit
I_{CC}	Quiescent Power Supply	$V_{CC} = 3.6\text{ V}$, $V_{IN} = V_{CC}$ or GND		150	500	μA

Table 12: LAN 8/16 MUX/DEMUX Dynamic Electrical Characteristics

($T_A = -40\text{ to }85^\circ\text{C}$, $V_{CC} = 3.3\text{V} \pm 10\%$)

Symbol	Parameter	Test Conditions	Min.	Typ.	Max.	Unit
Xtalk	Cross-Talk	$R_L = 100\ \Omega$, $f = 250\text{ MHz}$		-40		dB
OIRR	Off Isolation	$R_L = 100\ \Omega$, $f = 250\text{ MHz}$		-36		dB
BW	-3dB Bandwidth	$R_L = 100\ \Omega$		450		MHz

Table 13: LAN 8/16 MUX/DEMUX Switching Characteristics

($T_A = -40\text{ to }85^\circ\text{C}$, $V_{CC} = 3.3\text{V} \pm 10\%$)

Symbol	Parameter	Test Conditions	Min.	Typ.	Max.	Unit
t_{PD}	Propagation Delay	$V_{CC} = 3\text{ V to }3.6\text{ V}$		0.25		ns
t_{PZH} , t_{PZL}	Line Enable Time, SE to x to x0 or x to x1	$V_{CC} = 3\text{ V to }3.6\text{ V}$	0.5	6.5	9	ns
t_{PHZ} , t_{PLZ}	Line Disable Time, SE to x to x0 or x to x1	$V_{CC} = 3\text{ V to }3.6\text{ V}$	0.5	6.5	8.5	ns
$t_{SK(O)}$	Output Skew between center port to any other port	$V_{CC} = 3\text{ V to }3.6\text{ V}$		0.1	0.2	ns
$t_{SK(P)}$	Skew between opposite transition of the same output (t_{PHL} , t_{PLH})	$V_{CC} = 3\text{ V to }3.6\text{ V}$		0.1	0.2	ns

Note 4: x = A to H, x0 = A0 to H0, x1 = A1 to H1.

Table 14: Three Channel Switches Switching Characteristics

($T_A = -40\text{ to }85^\circ\text{C}$, $V_{CC} = 3.3\text{V} \pm 10\%$)

Symbol	Parameter	Test Conditions	Min.	Typ.	Max.	Unit
t_{ON}	Propagation Delay	$V_{CC} = 3\text{ V to }3.6\text{ V}$			50	ns
t_{OFF}	Propagation Delay	$V_{CC} = 3\text{ V to }3.6\text{ V}$			30	ns

Figure 3: Bandwidth

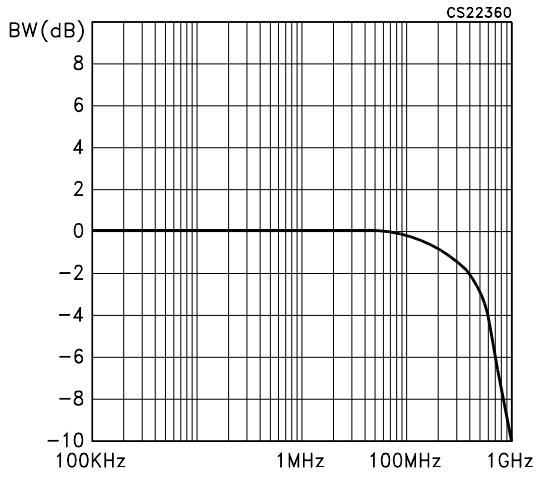
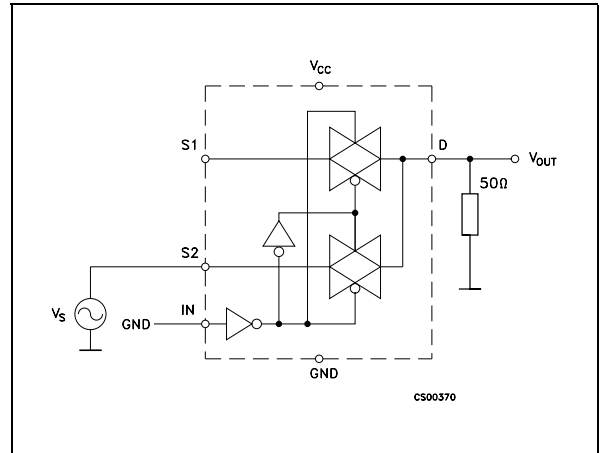
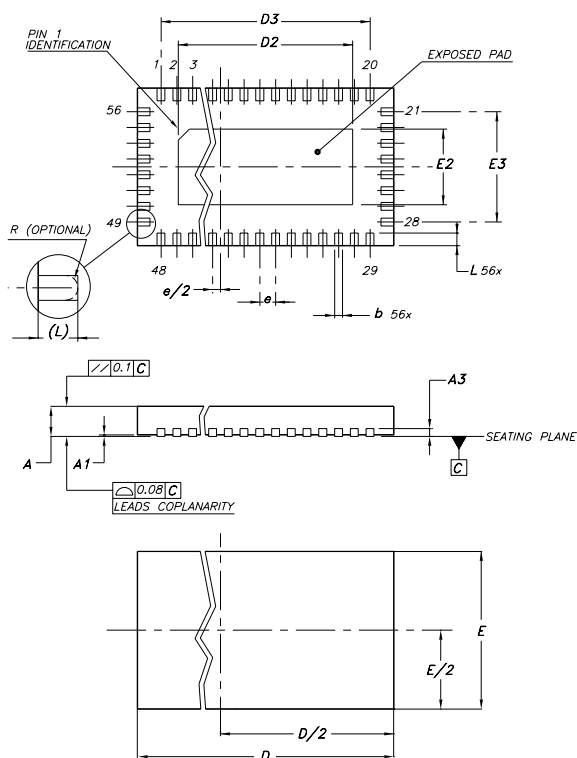

Figure 4: Schematic Bandwidth



QFN56 (11x5) MECHANICAL DATA

DIM.	mm.			inch		
	MIN.	TYP.	MAX.	MIN.	TYP.	MAX.
A	0.70	0.75	0.80	0.028	0.030	0.031
A1			0.05			0.002
A3		0.20			0.008	
b	0.20	0.25	0.30	0.008	0.010	0.012
D	10.90	11.00	11.10	0.429	0.433	0.437
D2	8.30	8.40	8.50	0.327	0.331	0.335
D3		9.50			0.374	
E	4.90	5.00	5.10	0.193	0.197	0.201
E2	2.30	2.40	2.50	0.091	0.094	0.098
E3		3.50			0.138	
e		0.50			0.020	
L	0.30	0.40	0.50	0.012	0.016	0.020



7576329-A

Table 15: Revision History

Date	Revision	Description of Changes
08-Apr-2005	1	First Release.
03-May-2005	2	Maturity Code.

Information furnished is believed to be accurate and reliable. However, STMicroelectronics assumes no responsibility for the consequences of use of such information nor for any infringement of patents or other rights of third parties which may result from its use. No license is granted by implication or otherwise under any patent or patent rights of STMicroelectronics. Specifications mentioned in this publication are subject to change without notice. This publication supersedes and replaces all information previously supplied. STMicroelectronics products are not authorized for use as critical components in life support devices or systems without express written approval of STMicroelectronics.

The ST logo is a registered trademark of STMicroelectronics

All other names are the property of their respective owners

© 2005 STMicroelectronics - All Rights Reserved

STMicroelectronics group of companies

Australia - Belgium - Brazil - Canada - China - Czech Republic - Finland - France - Germany - Hong Kong - India - Israel - Italy - Japan - Malaysia - Malta - Morocco - Singapore - Spain - Sweden - Switzerland - United Kingdom - United States of America

www.st.com

