

## FEATURES

- **Controlled Baseline**
  - One Assembly
  - One Test Site
  - One Fabrication Site
- **Extended Temperature Performance of –55°C to 125°C**
- **Enhanced Diminishing Manufacturing Sources (DMS) Support**
- **Enhanced Product-Change Notification**
- **Qualification Pedigree <sup>(1)</sup>**
- **Meets or Exceeds the Requirements of ANSI TIA/EIA-422-B, TIA/EIA-423-B, and ITU Recommendation V.10 and V.11**

(1) Component qualification in accordance with JEDEC and industry standards to ensure reliable operation over an extended temperature range. This includes, but is not limited to, Highly Accelerated Stress Test (HAST) or biased 85/85, temperature cycle, autoclave or unbiased HAST, electromigration, bond intermetallic life, and mold compound life. Such qualification testing should not be viewed as justifying use of this component beyond specified performance and environmental limits.

- **Low Power,  $I_{CC} = 10 \text{ mA Typ}$**
- **$\pm 7 \text{ V}$  Common-Mode Range With  $\pm 200 \text{ mV}$  Sensitivity**
- **Input Hysteresis . . .  $60 \text{ mV Typ}$**
- **$t_{pd} = 17 \text{ ns Typ}$**
- **Operates From a Single  $5 \text{ V}$  Supply**
- **3-State Outputs**
- **Input Fail-Safe Circuitry**
- **Improved Replacements for AM26LS32**

**AM26C32... D PACKAGE**  
(TOP VIEW)

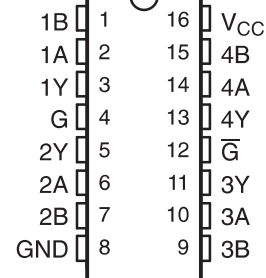

## DESCRIPTION/ORDERING INFORMATION

The AM26C32 is a quadruple differential line receiver for balanced or unbalanced digital data transmission. The enable function is common to all four receivers and offers a choice of active-high or active-low input. The 3-state outputs permit connection directly to a bus-organized system. Fail-safe design specifies that if the inputs are open, the outputs always are high.

The AM26C32 devices are manufactured using a BiCMOS process, which is a combination of bipolar and CMOS transistors. This process provides the high voltage and current of bipolar with the low power of CMOS to reduce the power consumption to about one-fifth that of the standard AM26LS32, while maintaining ac and dc performance.

The AM26C32 is characterized for operation over the extended temperature range of –55°C to 125°C.

### ORDERING INFORMATION<sup>(1)</sup>

$T_A$	PACKAGE <sup>(2)</sup>	ORDERABLE PART NUMBER	TOP-SIDE MARKING
–55°C to 125°C	SOIC – D Reel of 2500	AM26C32MDREP	26C32EP

(1) For the most current package and ordering information, see the Package Option Addendum at the end of this document, or see the TI website at [www.ti.com](http://www.ti.com).

(2) Package drawings, thermal data, and symbolization are available at [www.ti.com/packaging](http://www.ti.com/packaging).



Please be aware that an important notice concerning availability, standard warranty, and use in critical applications of Texas Instruments semiconductor products and disclaimers thereto appears at the end of this data sheet.

FUNCTION TABLE  
(each receiver)

DIFFERENTIAL INPUT	ENABLES		OUTPUT Y
	G	$\bar{G}$	
$V_{ID} \geq V_{IT+}$	H	X	H
	X	L	H
$V_{IT-} < V_{ID} < V_{IT+}$	H	X	?
	X	L	?
$V_{ID} \leq V_{IT-}$	H	X	L
	X	L	L
X	L	H	Z

**LOGIC DIAGRAM (POSITIVE LOGIC)**

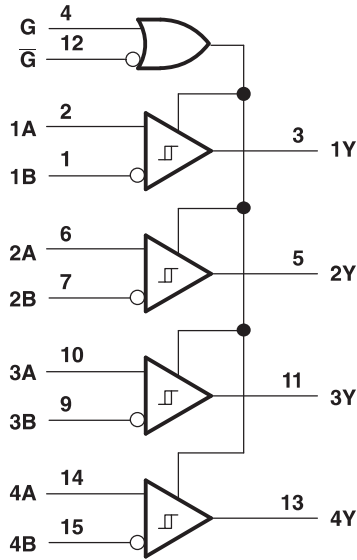

**SCHEMATICS**

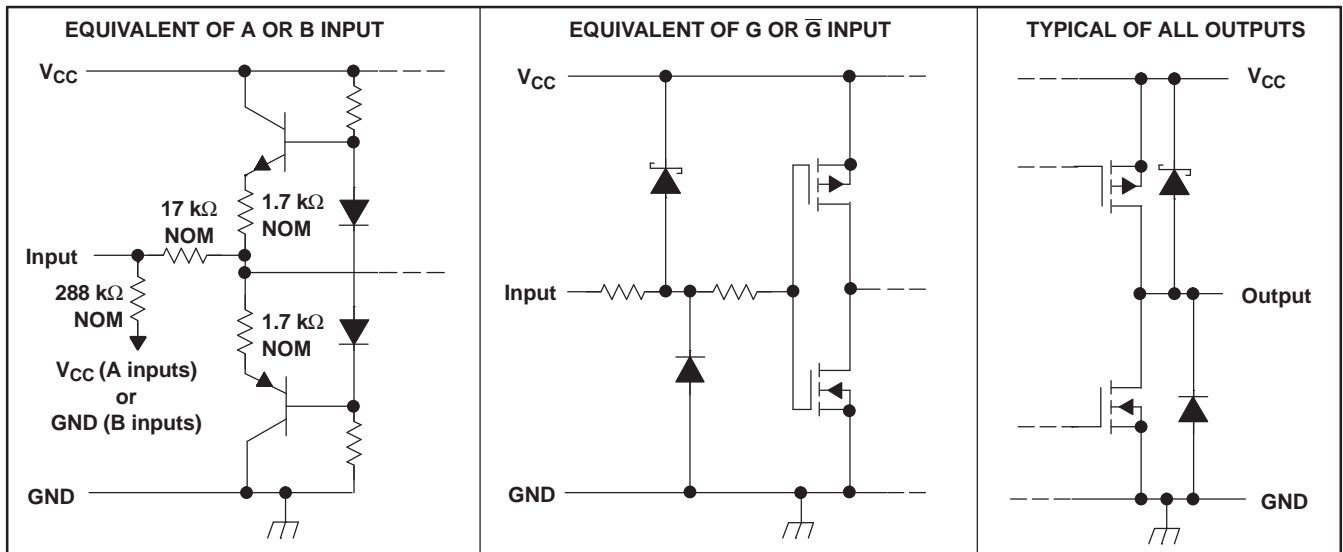

# AM26C32-EP QUADRUPLE DIFFERENTIAL LINE RECEIVER

SLLS870–NOVEMBER 2007

## ABSOLUTE MAXIMUM RATINGS<sup>(1)</sup>

over operating free-air temperature range (unless otherwise noted)

		MIN	MAX	UNIT
$V_{CC}$	Supply voltage <sup>(2)</sup>		7	V
$V_I$	Input voltage range	A or B inputs		V
		G or $\bar{G}$ inputs		V
$V_{ID}$	Differential input voltage range	-14	14	V
$V_O$	Output voltage range	-0.5	$V_{CC} + 0.5$	V
$I_O$	Output current		±25	mA
$\theta_{JA}$	Package thermal impedance <sup>(3)(4)</sup>	D package		°C/W
		PW package		°C/W
$T_J$	Operating virtual junction temperature		150	°C
	Lead temperature 1,6 mm (1/16 inch) from case for 10 seconds		260	°C
$T_{stg}$	Storage temperature range	-65	150	°C

- (1) Stresses beyond those listed under "absolute maximum ratings" may cause permanent damage to the device. These are stress ratings only, and functional operation of the device at these or any other conditions beyond those indicated under "recommended operating conditions" is not implied. Exposure to absolute-maximum-rated conditions for extended periods may affect device reliability.
- (2) All voltage values, except differential output voltage,  $V_{OD}$ , are with respect to network GND. Currents into the device are positive and currents out of the device are negative.
- (3) Maximum power dissipation is a function of  $T_J(\max)$ ,  $\theta_{JA}$ , and  $T_A$ . The maximum allowable power dissipation at any allowable ambient temperature is  $P_D = (T_J(\max) - T_A)/\theta_{JA}$ . Operating at the absolute maximum  $T_J$  of 150°C can affect reliability.
- (4) The package thermal impedance is calculated in accordance with JESD 51-7.

## RECOMMENDED OPERATING CONDITIONS

		MIN	NOM	MAX	UNIT
$V_{CC}$	Supply voltage	4.5	5	5.5	V
$V_{IH}$	High-level input voltage	2			V
$V_{IL}$	Low-level input voltage			0.8	V
$V_{IC}$	Common-mode input voltage			±7	V
$I_{OH}$	High-level output current			-6	mA
$I_{OL}$	Low-level output current			6	mA
$T_A$	Operating free-air temperature	-55		125	°C

## ELECTRICAL CHARACTERISTICS

over recommended ranges of  $V_{CC}$ ,  $V_{IC}$ , and operating free-air temperature (unless otherwise noted)

PARAMETER		TEST CONDITIONS		MIN	TYP <sup>(1)</sup>	MAX	UNIT
$V_{IT+}$	Differential input high-threshold voltage	$V_O = V_{OH}(\text{min}),$	$V_{IC} = -7\text{ V to }7\text{ V}$			0.2	V
		$I_{OH} = -440\ \mu\text{A}$	$V_{IC} = 0\text{ to }5.5\text{ V}$			0.1	
$V_{IT-}$	Differential input low-threshold voltage	$V_O = 0.45\text{ V},$	$V_{IC} = -7\text{ V to }7\text{ V}$	-0.2 <sup>(2)</sup>			V
		$I_{OL} = 8\text{ mA}$	$V_{IC} = 0\text{ to }5.5\text{ V}$	-0.1 <sup>(2)</sup>			
$V_{hys}$	Hysteresis voltage ( $V_{IT+} - V_{IT-}$ )				60		mV
$V_{IK}$	Enable input clamp voltage	$V_{CC} = 4.5\text{ V},$	$I_I = -18\text{ mA}$			-1.5	V
$V_{OH}$	High-level output voltage	$V_{ID} = 200\text{ mV},$	$I_{OH} = -6\text{ mA}$	3.8			V
$V_{OL}$	Low-level output voltage	$V_{ID} = -200\text{ mV},$	$I_{OL} = 6\text{ mA}$		0.2	0.3	V
$I_{OZ}$	Off-state (high-impedance state) output current	$V_O = V_{CC}\text{ or GND}$			$\pm 0.5$	$\pm 5$	$\mu\text{A}$
$I_I$	Line input current	$V_I = 10\text{ V},$	Other input at 0 V			1.5	mA
		$V_I = -10\text{ V},$	Other input at 0 V			-2.5	
$I_{IH}$	High-level enable current	$V_I = 2.7\text{ V}$				20	$\mu\text{A}$
$I_{IL}$	Low-level enable current	$V_I = 0.4\text{ V}$				-100	$\mu\text{A}$
$r_i$	Input resistance	One input to ground		12	17		k $\Omega$
$I_{CC}$	Supply current	$V_{CC} = 5.5\text{ V}$			10	15	mA

(1) All typical values are at  $V_{CC} = 5\text{ V}$ ,  $V_{IC} = 0$ , and  $T_A = 25^\circ\text{C}$ .

(2) The algebraic convention, in which the less positive (more negative) limit is designated minimum, is used in this data sheet for common-mode input voltage.

## SWITCHING CHARACTERISTICS

over recommended ranges of operation conditions,  $C_L = 50\text{ pF}$  (unless otherwise noted)

PARAMETER		TEST CONDITIONS	MIN	TYP <sup>(1)</sup>	MAX	UNIT
$t_{PLH}$	Propagation delay time, low- to high-level output	See Figure 1	9	17	27	ns
$t_{PHL}$	Propagation delay time, high- to low-level output		9	17	27	ns
$t_{TLH}$	Output transition time, low- to high-level output	See Figure 1		4	10	ns
$t_{THL}$	Output transition time, high- to low-level output			4	9	ns
$t_{PZH}$	Output enable time to high level	See Figure 2		13	22	ns
$t_{PZL}$	Output enable time to low level			13	22	ns
$t_{PHZ}$	Output disable time from high level	See Figure 2		13	26	ns
$t_{PLZ}$	Output disable time from low level			13	25	ns

(1) All typical values are at  $V_{CC} = 5\text{ V}$ ,  $T_A = 25^\circ\text{C}$ .

PARAMETER MEASUREMENT INFORMATION

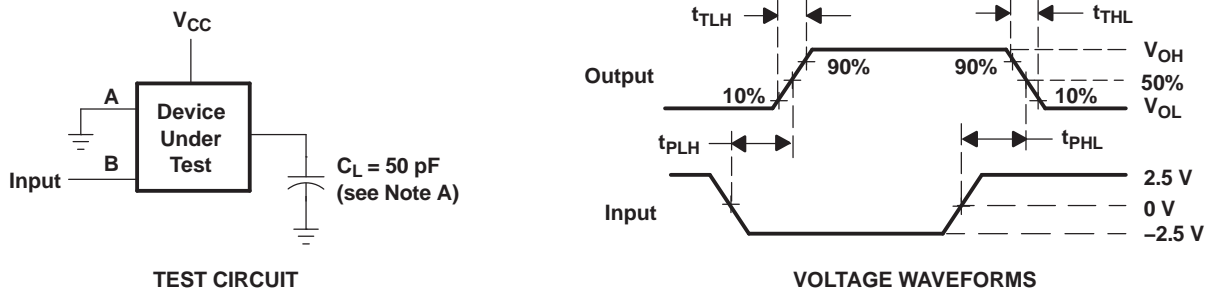

A.  $C_L$  includes probe and jig capacitance.

Figure 1. Switching Test Circuit and Voltage Waveforms

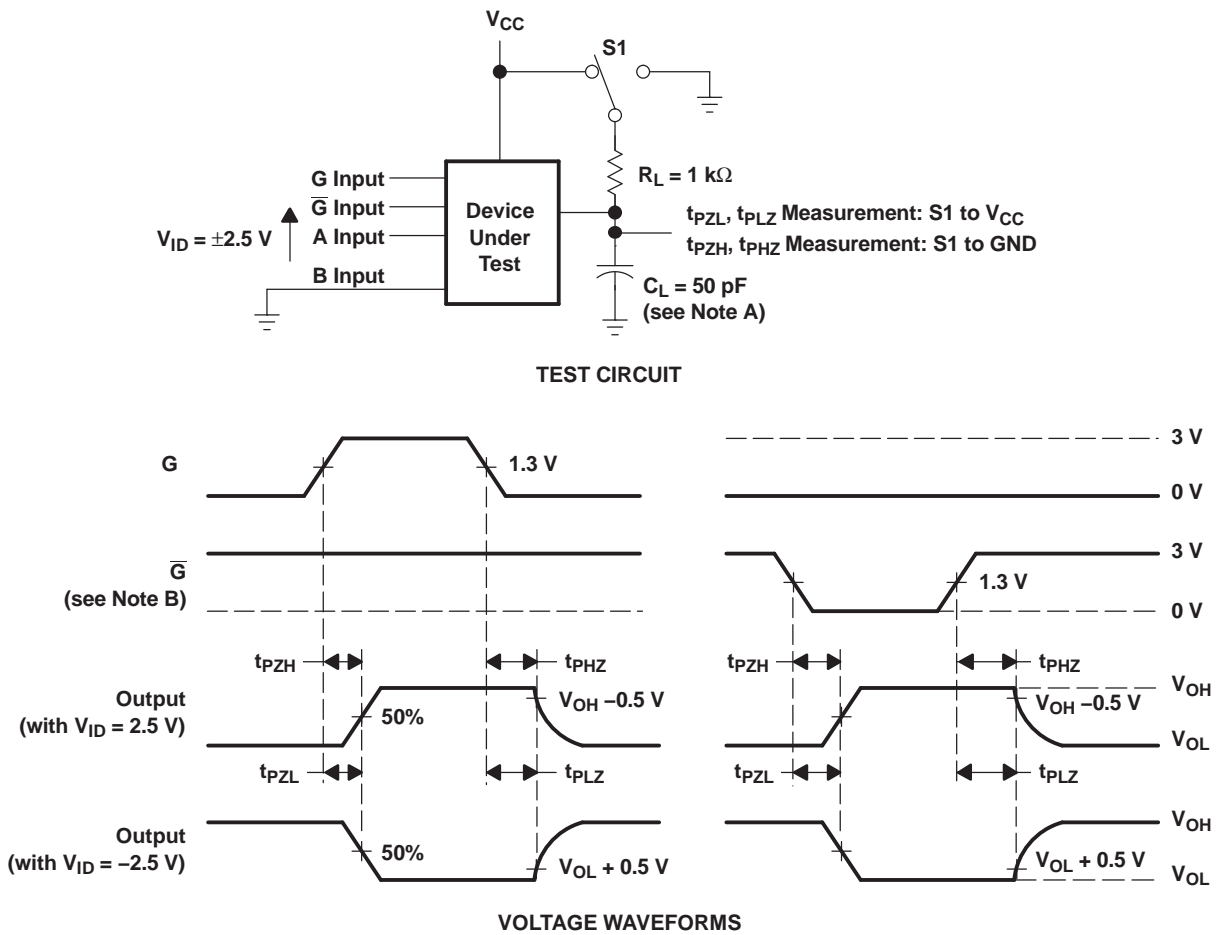

A.  $C_L$  includes probe and jig capacitance.

B. The input pulse is supplied by a generator having the following characteristics: PRR = 1 MHz, duty cycle  $\leq$  50%,  $t_r = t_f = 6$  ns.

Figure 2. Enable/Disable Time Test Circuit and Output Voltage Waveforms

**PACKAGING INFORMATION**

Orderable Device	Status <sup>(1)</sup>	Package Type	Package Drawing	Pins	Package Qty	Eco Plan <sup>(2)</sup>	Lead/Ball Finish	MSL Peak Temp <sup>(3)</sup>
AM26C32MDREP	ACTIVE	SOIC	D	16	2500	Green (RoHS & no Sb/Br)	CU NIPDAU	Level-1-260C-UNLIM
V62/07648-01XE	ACTIVE	SOIC	D	16	2500	Green (RoHS & no Sb/Br)	CU NIPDAU	Level-1-260C-UNLIM

<sup>(1)</sup> The marketing status values are defined as follows:

**ACTIVE:** Product device recommended for new designs.

**LIFEBUY:** TI has announced that the device will be discontinued, and a lifetime-buy period is in effect.

**NRND:** Not recommended for new designs. Device is in production to support existing customers, but TI does not recommend using this part in a new design.

**PREVIEW:** Device has been announced but is not in production. Samples may or may not be available.

**OBSOLETE:** TI has discontinued the production of the device.

<sup>(2)</sup> Eco Plan - The planned eco-friendly classification: Pb-Free (RoHS), Pb-Free (RoHS Exempt), or Green (RoHS & no Sb/Br) - please check <http://www.ti.com/productcontent> for the latest availability information and additional product content details.

**TBD:** The Pb-Free/Green conversion plan has not been defined.

**Pb-Free (RoHS):** TI's terms "Lead-Free" or "Pb-Free" mean semiconductor products that are compatible with the current RoHS requirements for all 6 substances, including the requirement that lead not exceed 0.1% by weight in homogeneous materials. Where designed to be soldered at high temperatures, TI Pb-Free products are suitable for use in specified lead-free processes.

**Pb-Free (RoHS Exempt):** This component has a RoHS exemption for either 1) lead-based flip-chip solder bumps used between the die and package, or 2) lead-based die adhesive used between the die and leadframe. The component is otherwise considered Pb-Free (RoHS compatible) as defined above.

**Green (RoHS & no Sb/Br):** TI defines "Green" to mean Pb-Free (RoHS compatible), and free of Bromine (Br) and Antimony (Sb) based flame retardants (Br or Sb do not exceed 0.1% by weight in homogeneous material)

<sup>(3)</sup> MSL, Peak Temp. -- The Moisture Sensitivity Level rating according to the JEDEC industry standard classifications, and peak solder temperature.

**Important Information and Disclaimer:**The information provided on this page represents TI's knowledge and belief as of the date that it is provided. TI bases its knowledge and belief on information provided by third parties, and makes no representation or warranty as to the accuracy of such information. Efforts are underway to better integrate information from third parties. TI has taken and continues to take reasonable steps to provide representative and accurate information but may not have conducted destructive testing or chemical analysis on incoming materials and chemicals. TI and TI suppliers consider certain information to be proprietary, and thus CAS numbers and other limited information may not be available for release.

In no event shall TI's liability arising out of such information exceed the total purchase price of the TI part(s) at issue in this document sold by TI to Customer on an annual basis.

**OTHER QUALIFIED VERSIONS OF AM26C32-EP :**

- Catalog: [AM26C32](#)
- Military: [AM26C32M](#)

NOTE: Qualified Version Definitions:



- Catalog - TI's standard catalog product
- Military - QML certified for Military and Defense Applications

D (R-PDSO-G16)

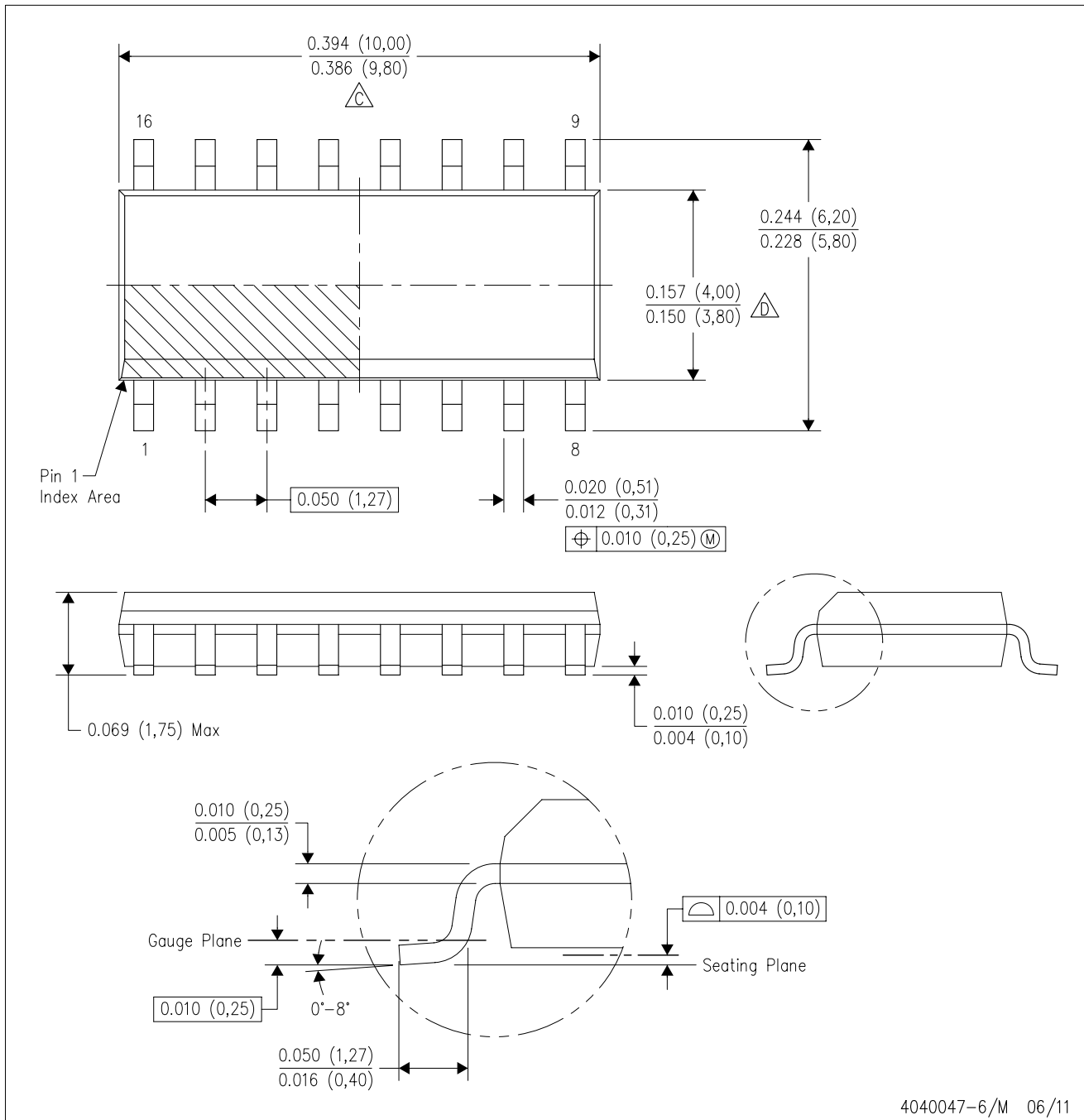
PLASTIC SMALL OUTLINE



4040047-6/M 06/11

- NOTES:
- A. All linear dimensions are in inches (millimeters).
  - B. This drawing is subject to change without notice.
  -  Body length does not include mold flash, protrusions, or gate burrs. Mold flash, protrusions, or gate burrs shall not exceed 0.006 (0,15) each side.
  -  Body width does not include interlead flash. Interlead flash shall not exceed 0.017 (0,43) each side.
  - E. Reference JEDEC MS-012 variation AC.



D (R-PDSO-G16)

PLASTIC SMALL OUTLINE

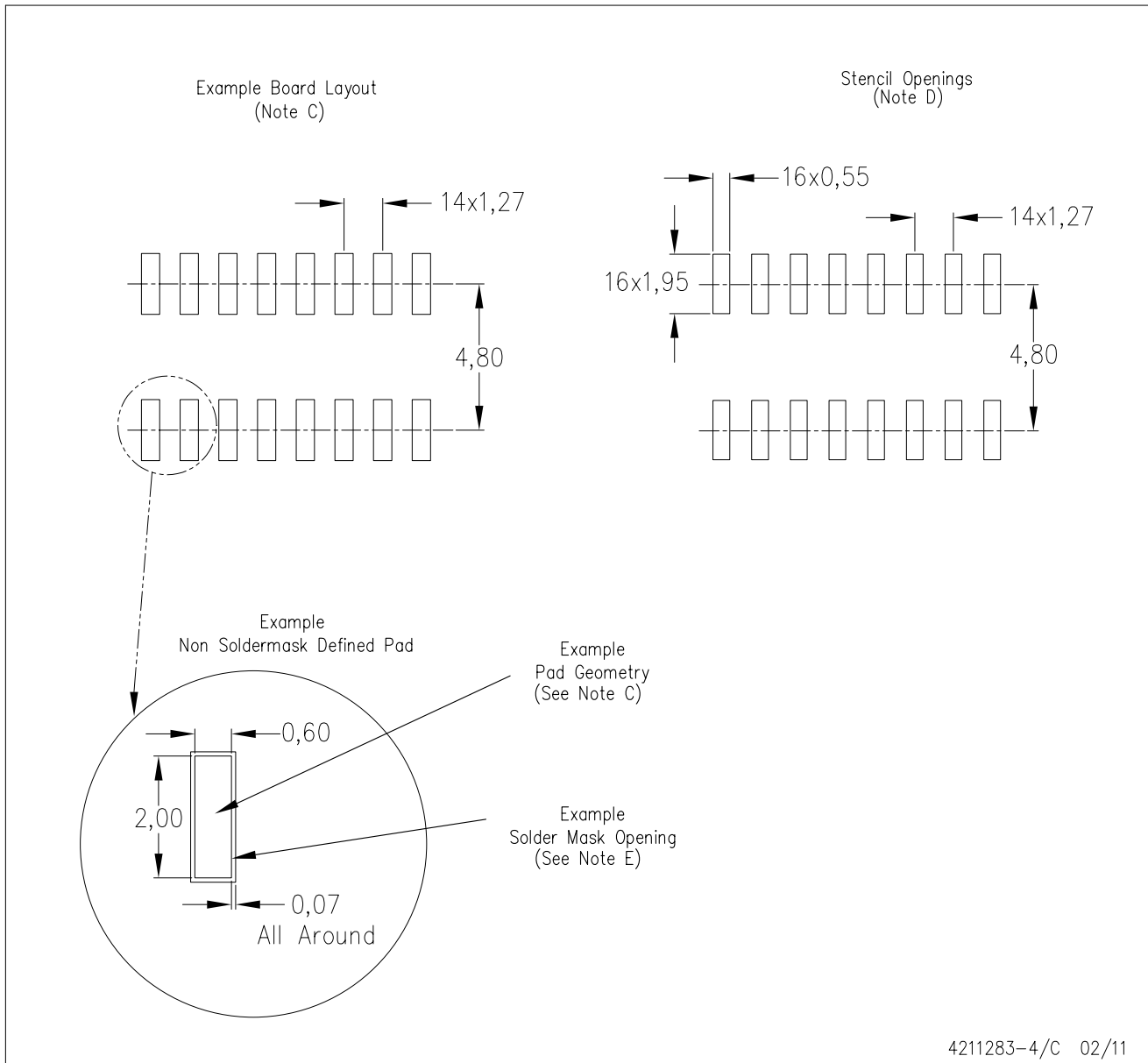

- NOTES:
- All linear dimensions are in millimeters.
  - This drawing is subject to change without notice.
  - Publication IPC-7351 is recommended for alternate designs.
  - Laser cutting apertures with trapezoidal walls and also rounding corners will offer better paste release. Customers should contact their board assembly site for stencil design recommendations. Refer to IPC-7525 for other stencil recommendations.
  - Customers should contact their board fabrication site for solder mask tolerances between and around signal pads.

## IMPORTANT NOTICE

Texas Instruments Incorporated and its subsidiaries (TI) reserve the right to make corrections, modifications, enhancements, improvements, and other changes to its products and services at any time and to discontinue any product or service without notice. Customers should obtain the latest relevant information before placing orders and should verify that such information is current and complete. All products are sold subject to TI's terms and conditions of sale supplied at the time of order acknowledgment.

TI warrants performance of its hardware products to the specifications applicable at the time of sale in accordance with TI's standard warranty. Testing and other quality control techniques are used to the extent TI deems necessary to support this warranty. Except where mandated by government requirements, testing of all parameters of each product is not necessarily performed.

TI assumes no liability for applications assistance or customer product design. Customers are responsible for their products and applications using TI components. To minimize the risks associated with customer products and applications, customers should provide adequate design and operating safeguards.

TI does not warrant or represent that any license, either express or implied, is granted under any TI patent right, copyright, mask work right, or other TI intellectual property right relating to any combination, machine, or process in which TI products or services are used. Information published by TI regarding third-party products or services does not constitute a license from TI to use such products or services or a warranty or endorsement thereof. Use of such information may require a license from a third party under the patents or other intellectual property of the third party, or a license from TI under the patents or other intellectual property of TI.

Reproduction of TI information in TI data books or data sheets is permissible only if reproduction is without alteration and is accompanied by all associated warranties, conditions, limitations, and notices. Reproduction of this information with alteration is an unfair and deceptive business practice. TI is not responsible or liable for such altered documentation. Information of third parties may be subject to additional restrictions.

Resale of TI products or services with statements different from or beyond the parameters stated by TI for that product or service voids all express and any implied warranties for the associated TI product or service and is an unfair and deceptive business practice. TI is not responsible or liable for any such statements.

TI products are not authorized for use in safety-critical applications (such as life support) where a failure of the TI product would reasonably be expected to cause severe personal injury or death, unless officers of the parties have executed an agreement specifically governing such use. Buyers represent that they have all necessary expertise in the safety and regulatory ramifications of their applications, and acknowledge and agree that they are solely responsible for all legal, regulatory and safety-related requirements concerning their products and any use of TI products in such safety-critical applications, notwithstanding any applications-related information or support that may be provided by TI. Further, Buyers must fully indemnify TI and its representatives against any damages arising out of the use of TI products in such safety-critical applications.

TI products are neither designed nor intended for use in military/aerospace applications or environments unless the TI products are specifically designated by TI as military-grade or "enhanced plastic." Only products designated by TI as military-grade meet military specifications. Buyers acknowledge and agree that any such use of TI products which TI has not designated as military-grade is solely at the Buyer's risk, and that they are solely responsible for compliance with all legal and regulatory requirements in connection with such use.

TI products are neither designed nor intended for use in automotive applications or environments unless the specific TI products are designated by TI as compliant with ISO/TS 16949 requirements. Buyers acknowledge and agree that, if they use any non-designated products in automotive applications, TI will not be responsible for any failure to meet such requirements.

Following are URLs where you can obtain information on other Texas Instruments products and application solutions:

### Products

Audio	<a href="http://www.ti.com/audio">www.ti.com/audio</a>
Amplifiers	<a href="http://amplifier.ti.com">amplifier.ti.com</a>
Data Converters	<a href="http://dataconverter.ti.com">dataconverter.ti.com</a>
DLP® Products	<a href="http://www.dlp.com">www.dlp.com</a>
DSP	<a href="http://dsp.ti.com">dsp.ti.com</a>
Clocks and Timers	<a href="http://www.ti.com/clocks">www.ti.com/clocks</a>
Interface	<a href="http://interface.ti.com">interface.ti.com</a>
Logic	<a href="http://logic.ti.com">logic.ti.com</a>
Power Mgmt	<a href="http://power.ti.com">power.ti.com</a>
Microcontrollers	<a href="http://microcontroller.ti.com">microcontroller.ti.com</a>
RFID	<a href="http://www.ti-rfid.com">www.ti-rfid.com</a>
RF/IF and ZigBee® Solutions	<a href="http://www.ti.com/lprf">www.ti.com/lprf</a>

### Applications

Communications and Telecom	<a href="http://www.ti.com/communications">www.ti.com/communications</a>
Computers and Peripherals	<a href="http://www.ti.com/computers">www.ti.com/computers</a>
Consumer Electronics	<a href="http://www.ti.com/consumer-apps">www.ti.com/consumer-apps</a>
Energy and Lighting	<a href="http://www.ti.com/energy">www.ti.com/energy</a>
Industrial	<a href="http://www.ti.com/industrial">www.ti.com/industrial</a>
Medical	<a href="http://www.ti.com/medical">www.ti.com/medical</a>
Security	<a href="http://www.ti.com/security">www.ti.com/security</a>
Space, Avionics and Defense	<a href="http://www.ti.com/space-avionics-defense">www.ti.com/space-avionics-defense</a>
Transportation and Automotive	<a href="http://www.ti.com/automotive">www.ti.com/automotive</a>
Video and Imaging	<a href="http://www.ti.com/video">www.ti.com/video</a>
Wireless	<a href="http://www.ti.com/wireless-apps">www.ti.com/wireless-apps</a>

TI E2E Community Home Page

[e2e.ti.com](http://e2e.ti.com)

Mailing Address: Texas Instruments, Post Office Box 655303, Dallas, Texas 75265  
Copyright © 2011, Texas Instruments Incorporated

[www.BDTIC.com/TI/](http://www.BDTIC.com/TI/)