

LM4671

LM4671 Filterless High Efficiency 2.5W Switching Audio Amplifier



Literature Number: SNAS258C

www.BDTIC.com/TI

LM4671 Boomer® Audio Power Amplifier Series

Filterless High Efficiency 2.5W Switching Audio Amplifier

General Description

The LM4671 is a single supply, high efficiency 2.5W switching audio amplifier. A low noise, filterless PWM architecture eliminates the output filter, reducing external component count, board area consumption, system cost, and simplifying design.

The LM4671 is designed to meet the demands of mobile phones and other portable communication devices. Operating on a single 5V supply, it is capable of driving a 4Ω speaker load at a continuous average output of 2.1W with less than 1% THD+N. Its flexible power supply requirements allow operation from 2.4V to 5.5V.

The LM4671 has high efficiency with speaker loads compared to a typical Class AB amplifier. With a 3V supply driving an 8Ω speaker, the IC's efficiency for a 100mW power level is 80%, reaching 88% at 400mW output power.

The LM4671 features a low-power consumption shutdown mode. Shutdown may be enabled by driving the Shutdown pin to a logic low (GND).

The gain of the LM4671 is externally configurable which allows independent gain control from multiple sources by summing the signals.

Key Specifications

| | |
|--|--------------|
| ■ Efficiency @ 3.6V, 100mW into 8Ω speaker | 80% (typ) |
| ■ Efficiency @ 3.6V, 400mW into 8Ω speaker | 88% (typ) |
| ■ Efficiency @ 5V, 1W into 8Ω speaker | 86% (typ) |
| ■ Quiescent current, 3.6V supply | 2.8mA (typ) |
| ■ Total shutdown power supply current | 0.01μA (typ) |
| ■ Single supply range | 2.4V to 5.5V |

Features

- No output filter required for inductive loads
- Externally configurable gain
- Very fast turn on time: 17μs (typ)
- Minimum external components
- "Click and pop" suppression circuitry
- Micro-power shutdown mode
- Available in space-saving microSMD package

Applications

- Mobile phones
- PDAs
- Portable electronic devices

Typical Application

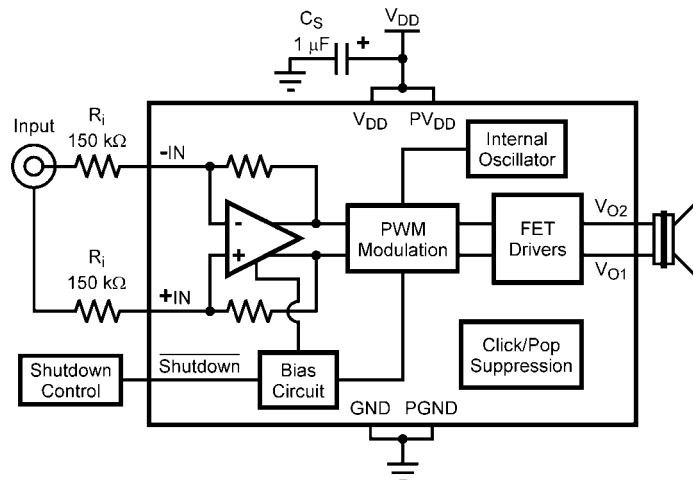

201073j3

FIGURE 1. Typical Audio Amplifier Application Circuit

Boomer® is a registered trademark of National Semiconductor Corporation.

Connection Diagrams

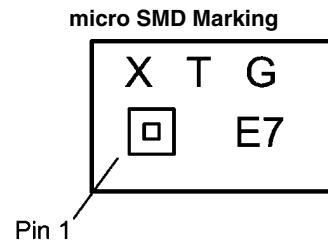
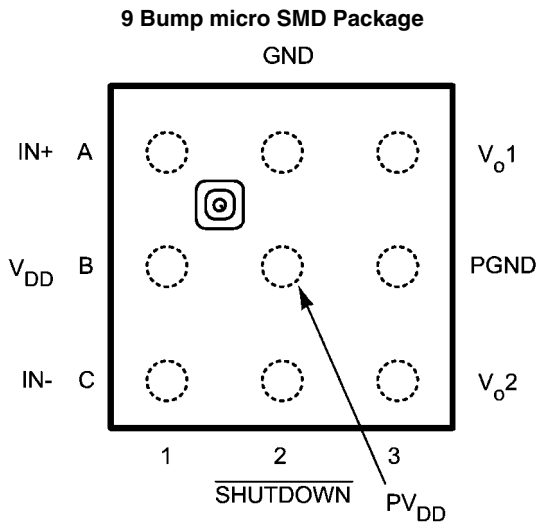

Top View
 X — Date Code
 T — Die Traceability
 G — Boomer Family
 E7 — LM4671ITL

201073c6

20107336

Top View
 Order Number LM4671ITL, LM4671ITLX
 See NS Package Number TLA09AAA

Absolute Maximum Ratings (Notes 1, 2)

If Military/Aerospace specified devices are required, please contact the National Semiconductor Sales Office/Distributors for availability and specifications.

| | |
|---|--|
| Supply Voltage (Note 1) | 6.0V |
| Storage Temperature | -65°C to +150°C |
| Voltage at Any Input Pin | $V_{DD} + 0.3V \geq V \geq GND - 0.3V$ |
| Power Dissipation (Note 3) | Internally Limited |
| ESD Susceptibility, all other pins (Note 4) | 2.0kV |
| ESD Susceptibility (Note 5) | 200V |
| Junction Temperature (T_{JMAX}) | 150°C |

Thermal Resistance

 θ_{JA} (micro SMD)

220°C/W

Soldering Information

See AN-1112 "microSMD Wafers Level Chip Scale Package."

Operating Ratings (Notes 1, 2)

Temperature Range

 $T_{MIN} \leq T_A \leq T_{MAX}$ $-40^\circ\text{C} \leq T_A \leq 85^\circ\text{C}$

Supply Voltage

 $2.4V \leq V_{DD} \leq 5.5V$ **Electrical Characteristics** (Notes 1, 2)

The following specifications apply for $A_V = 2V/V$ ($R_I = 150k\Omega$), $R_L = 15\mu H + 8\Omega + 15\mu H$ unless otherwise specified. Limits apply for $T_A = 25^\circ\text{C}$.

| Symbol | Parameter | Conditions | LM4671 | | Units (Limits) |
|--------------|-------------------------------------|--|------------------|--------------------------------------|------------------------|
| | | | Typical | Limit | |
| | | | (Note 6) | (Notes 7, 8) | |
| IV_{OS} | Differential Output Offset Voltage | $V_I = 0V$, $A_V = 2V/V$, $V_{DD} = 2.4V$ to $5.0V$ | 5 | | mV (max) |
| $PSRR_{GSM}$ | GSM Power Supply Rejection Ratio | $V_{DD} = 2.4V$ to $5.0V$ | 61 | | dB (min) |
| $CMRR_{GSM}$ | GSM Common Mode Rejection Ratio | $V_{DD} = 2.4V$ to $5.0V$ $V_{IC} = V_{DD}/2$ to $0.5V$, $V_{IC} = V_{DD}/2$ to $V_{DD} - 0.8V$ | 68 | | dB (min) |
| I_{IH} | Logic High Input Current | $V_{DD} = 5.0V$, $V_I = 5.5V$ | 17 | 100 | μA (max) |
| I_{IL} | Logic Low Input Current | $V_{DD} = 5.0V$, $V_I = -0.3V$ | 0.9 | 5 | μA (max) |
| I_{DD} | Quiescent Power Supply Current | $V_{IN} = 0V$, No Load, $V_{DD} = 5.0V$ | 6.4 | | mA (max) |
| | | $V_{IN} = 0V$, No Load, $V_{DD} = 3.6V$ | 3.8 | 6.2 | mA |
| | | $V_{IN} = 0V$, No Load, $V_{DD} = 2.4V$ | 2.0 | 3.0 | mA (max) |
| I_{SD} | Shutdown Current | $V_{SHUTDOWN} = 0V$ $V_{DD} = 2.4V$ to $5.0V$ | 0.01 | 1 | μA (max) |
| V_{SDIH} | Shutdown voltage input high | | 1.2 | 1.4 | V (min) |
| V_{SDIL} | Shutdown voltage input low | | 1.1 | 0.4 | V (max) |
| R_{OSD} | Output Impedance | $V_{SHUTDOWN} = 0.4V$ | 100 | | $k\Omega$ |
| A_V | Gain | | $300k\Omega/R_I$ | $270k\Omega/R_I$ $330k\Omega/R_I$ | V/V (min) V/V (max) |
| R_{SD} | Resistance from Shutdown Pin to GND | | 300 | | $k\Omega$ |
| P_O | Output Power | $R_L = 15\mu H + 4\Omega + 15\mu H$ THD = 10% (max) $f = 1kHz$, 22kHz BW $V_{DD} = 5V$ | 2.5 | | W |
| | | $V_{DD} = 3.6V$ | 1.3 | | W |
| | | $V_{DD} = 2.5V$ | 520 | | mW |
| | | $R_L = 15\mu H + 4\Omega + 15\mu H$ THD = 1% (max) $f = 1kHz$, 22kHz BW $V_{DD} = 5V$ | 2.21 | | W |
| | | $V_{DD} = 3.6V$ | 1.06 | | W |
| | | $V_{DD} = 2.5V$ | 420 | | mW |

| Symbol | Parameter | Conditions | LM4671 | | Units (Limits) |
|------------------|-----------------------------------|--|----------|--------------|-------------------|
| | | | Typical | Limit | |
| | | | (Note 6) | (Notes 7, 8) | |
| P _O | Output Power | R _L = 15μH + 8Ω + 15μH THD = 10% (max) f = 1kHz, 22kHz BW | | | |
| | | V _{DD} = 5V | 1.7 | | W |
| | | V _{DD} = 3.6V | 870 | | mW |
| | | V _{DD} = 2.5V | 425 | | mW |
| | | R _L = 15μH + 8Ω + 15μH THD = 1% (max) f = 1kHz, 22kHz BW | | | |
| | | V _{DD} = 5V | 1.19 | | W |
| | | V _{DD} = 3.6V | 700 | 600 | mW |
| | | V _{DD} = 2.5V | 350 | | mW |
| THD+N | Total Harmonic Distortion + Noise | V _{DD} = 5V, P _O = 0.1W _{RMS} , f = 1kHz | 0.09 | | % |
| | | V _{DD} = 3.6V, P _O = 0.1W _{RMS} , f = 1kHz | 0.04 | | % |
| | | V _{DD} = 3.6V, P _O = 0.1W _{RMS} , f = 5kHz | 0.12 | | % |
| | | V _{DD} = 3.6V, P _O = 0.1W _{RMS} , f = 10kHz | 0.05 | | % |
| PSRR | Power Supply Rejection Ratio | V _{DD} = 3.6V, 5V V _{Ripple} = 200mV _{PP} Sine, f _{Ripple} = 217Hz Inputs to AC GND, C ₁ = 2μF | 61.8 | | dB |
| | | V _{DD} = 3.6V, 5V V _{Ripple} = 200mV _{PP} Sine, f _{Ripple} = 1kHz Inputs to AC GND, C ₁ = 2μF | 59.8 | | dB |
| | | V _{DD} = 3.6V, 5V V _{Ripple} = 200mV _{PP} Sine, f _{Ripple} = 10kHz Inputs to AC GND, C ₁ = 2μF | 48.7 | | dB |
| | | V _{DD} = 3.6V, 5V V _{Ripple} = 200mV _{PP} Sine, f _{Ripple} = 217Hz f _{IN} = 1kHz, P _O = 10mW _{RMS} | 65.7 | | dB |
| | | V _{DD} = 3.6V, 5V V _{Ripple} = 200mV _{PP} Sine, f _{Ripple} = 217Hz f _{IN} = 1kHz, P _O = 10mW _{RMS} | 65.7 | | dB |
| SNR | Signal to Noise Ratio | V _{DD} = 5V, P _O = 1W _{RMS} | 93 | | dB |
| ε _{OUT} | Output Noise | V _{DD} = 3.6V, f = 20Hz – 20kHz Inputs to AC GND, C ₁ = 2μF No Weighting | 58 | | μV _{RMS} |
| | | V _{DD} = 3.6V, Inputs to AC GND C ₁ = 2μF, A Weighted | 38 | | μV _{RMS} |
| CMRR | Common Mode Rejection Ratio | V _{DD} = 3.6V, V _{Ripple} = 1V _{PP} Sine f _{Ripple} = 217Hz | 68.3 | | dB |
| T _{WU} | Wake-up Time | V _{DD} = 3.6V | 17 | 49 | μs (max) |
| T _{SD} | Shutdown Time | | 140 | | μs |

Note 1: All voltages are measured with respect to the ground pin, unless otherwise specified.

Note 2: *Absolute Maximum Ratings* indicate limits beyond which damage to the device may occur. *Operating Ratings* indicate conditions for which the device is functional, but do not guarantee specific performance limits. *Electrical Characteristics* state DC and AC electrical specifications under particular test conditions which guarantee specific performance limits. This assumes that the device is within the Operating Ratings. Specifications are not guaranteed for parameters where no limit is given, however, the typical value is a good indication of device performance.

Note 3: The maximum power dissipation must be derated at elevated temperatures and is dictated by T_{JMAX} , θ_{JA} , and the ambient temperature T_A . The maximum allowable power dissipation is $P_{DMAX} = (T_{JMAX} - T_A) / \theta_{JA}$ or the number given in Absolute Maximum Ratings, whichever is lower. For the LM4671, $T_{JMAX} = 150^\circ\text{C}$. The typical θ_{JA} is 220°C/W for the microSMD package.

Note 4: Human body model, 100pF discharged through a 1.5k Ω resistor.

Note 5: Machine Model, 220pF–240pF discharged through all pins.

Note 6: Typical specifications are specified at 25°C and represent the parametric norm.

Note 7: Tested limits are guaranteed to National's AOQL (Average Outgoing Quality Level).

Note 8: Datasheet min/max specification limits are guaranteed by design, test, or statistical analysis.

Note 9: Shutdown current is measured in a normal room environment. Exposure to direct sunlight will increase I_{SD} by a maximum of 2 μA . The Shutdown pin should be driven as close as possible to GND for minimal shutdown current and to V_{DD} for the best THD performance in PLAY mode. See the **Application Information** section under SHUTDOWN FUNCTION for more information.

Note 10: The performance graphs were taken using the Audio Precision AUX-0025 Switching Amplifier measurement Filter in series with the LC filter on the demo board.

External Components Description

(Figure 1)

| Components | | Functional Description |
|------------|-------|---|
| 1. | C_S | Supply bypass capacitor which provides power supply filtering. Refer to the Power Supply Bypassing section for information concerning proper placement and selection of the supply bypass capacitor. |
| 2. | C_I | Input AC coupling capacitor which blocks the DC voltage at the amplifier's input terminals. |

Typical Performance Characteristics

THD+N vs Frequency
 $V_{DD} = 2.4V$, $R_L = 15\mu H + 4\Omega + 15\mu H$,
 $P_O = 375mW$, 22kHz BW

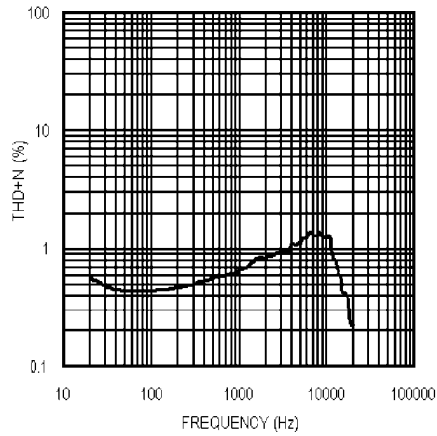

20107303

THD+N vs Frequency
 $V_{DD} = 3.6V$, $R_L = 15\mu H + 4\Omega + 15\mu H$,
 $P_O = 750mW$, 22kHz BW

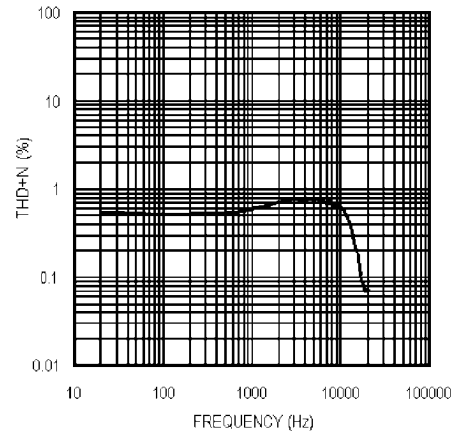

20107304

THD+N vs Frequency
 $V_{DD} = 5V$, $R_L = 15\mu H + 4\Omega + 15\mu H$,
 $P_O = 1.5mW$, 22kHz BW

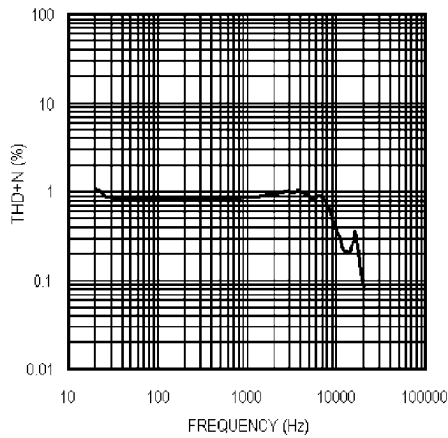

20107305

THD+N vs Frequency
 $V_{DD} = 2.4V$, $R_L = 15\mu H + 8\Omega + 15\mu H$,
 $P_O = 200mW$, 22kHz BW

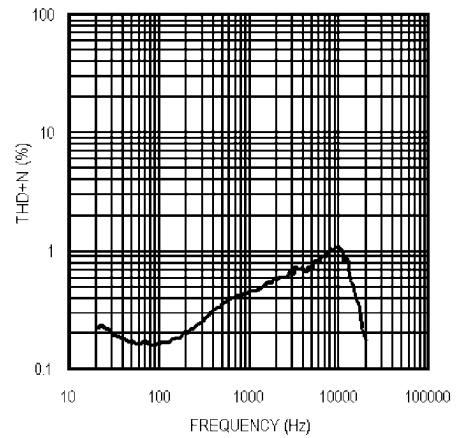

20107306

THD+N vs Frequency
 $V_{DD} = 3.6V$, $R_L = 15\mu H + 8\Omega + 15\mu H$,
 $P_O = 500mW$, 22kHz BW

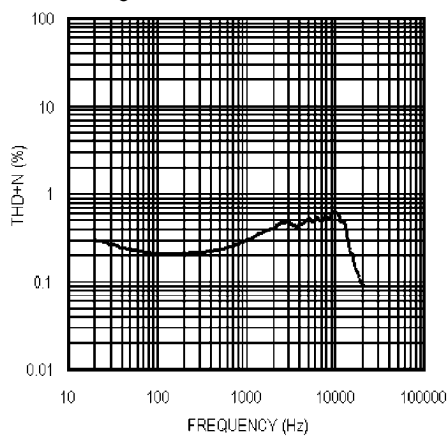

20107307

THD+N vs Frequency
 $V_{DD} = 5V$, $R_L = 15\mu H + 8\Omega + 15\mu H$,
 $P_O = 1W$, 22kHz BW

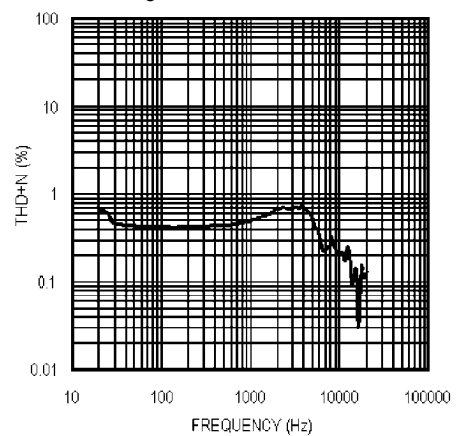

20107308

THD+N vs Output Power
 $V_{DD} = 5V$, $R_L = 15\mu H + 4\Omega + 15\mu H$,
 $f = 1kHz$, 22kHz BW

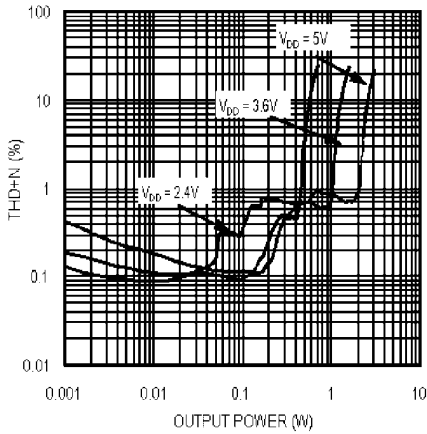

20107309

THD+N vs Output Power
 $V_{DD} = 5V$, $R_L = 15\mu H + 8\Omega + 15\mu H$,
 $f = 1kHz$, 22kHz BW

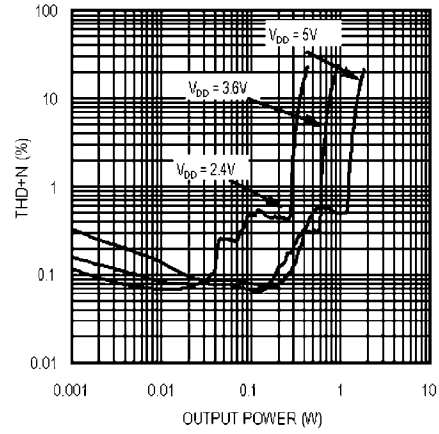

20107310

CMRR vs Frequency
 $V_{DD} = 3.6V$, $R_L = 15\mu H + 8\Omega + 15\mu H$,
 $V_{ripple} = 1V_{p-p}$, 22kHz BW

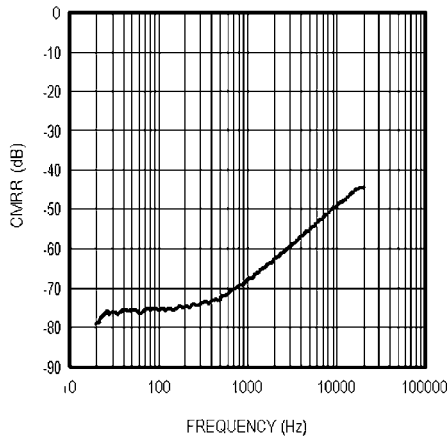

20107311

PSRR vs Frequency
 $V_{DD} = 3.6V$, $R_L = 15\mu H + 8\Omega + 15\mu H$,
 $V_{ripple} = 200mV_{p-p}$, 22kHz BW

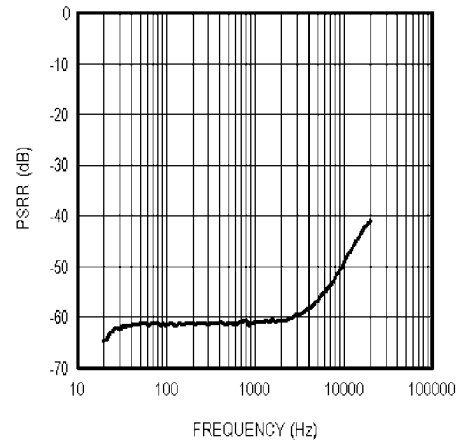

20107312

Efficiency vs Output Power
 $R_L = 15\mu H + 4\Omega + 15\mu H$,
 $f = 1kHz$, 22kHz BW

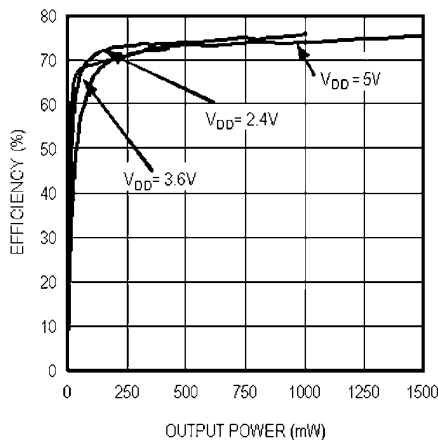

20107313

Efficiency vs Output Power
 $R_L = 15\mu H + 8\Omega + 15\mu H$,
 $f = 1kHz$, 22kHz BW

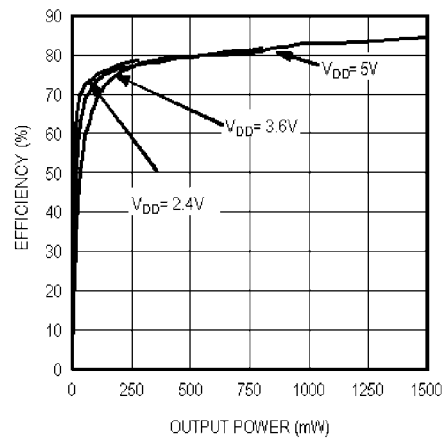

20107314

Power Dissipation vs Output Power
 $R_L = 15\mu H + 4\Omega + 15\mu H$,
 $f = 1\text{kHz}, 22\text{kHz BW}$

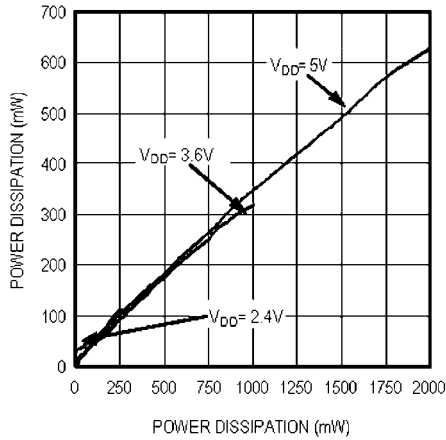

20107315

Power Dissipation vs Output Power
 $R_L = 15\mu H + 8\Omega + 15\mu H$,
 $f = 1\text{kHz}, 22\text{kHz BW}$

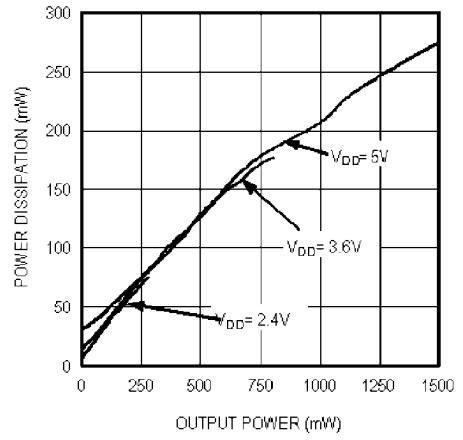

20107316

Output Power vs Supply Voltage
 $R_L = 15\mu H + 4\Omega + 15\mu H$,
 $V_{DD} = 3.6\text{V}$

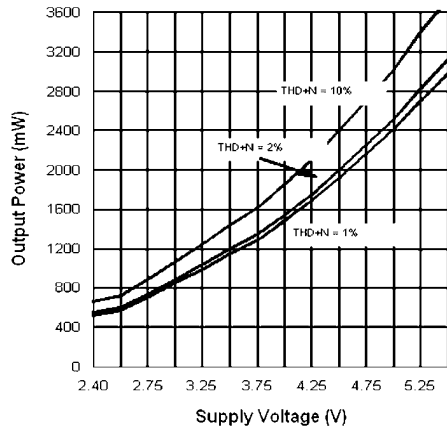

20107317

Output Power vs Supply Voltage
 $R_L = 15\mu H + 8\Omega + 15\mu H$,
 $V_{DD} = 3.6\text{V}$

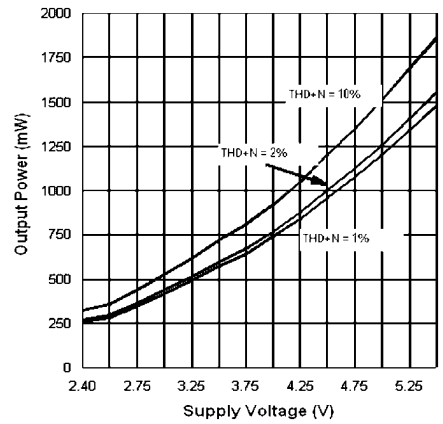

20107318

Gain vs Supply Voltage
 $R_{in} = 150\text{k}\Omega$

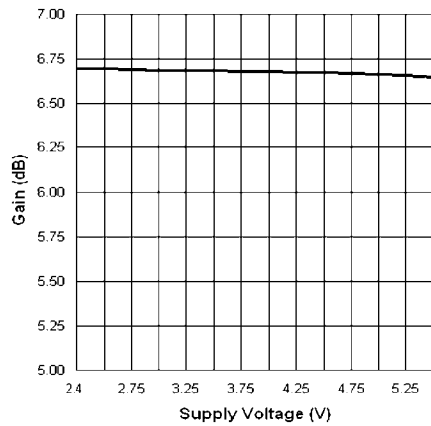

20107319

Supply Current vs Supply Voltage
 $R_L = 15\mu H + 8\Omega + 15\mu H$

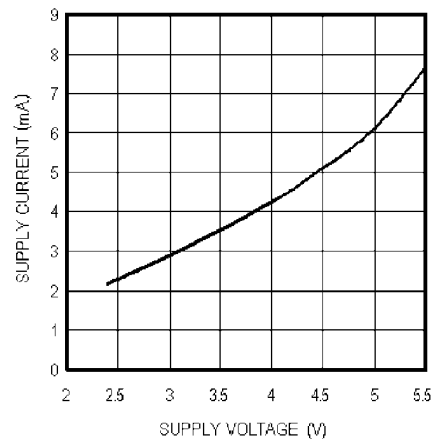

20107320

Shutdown Current vs Supply Voltage
 $R_L = 15\mu\text{H} + 8\Omega + 15\mu\text{H}$

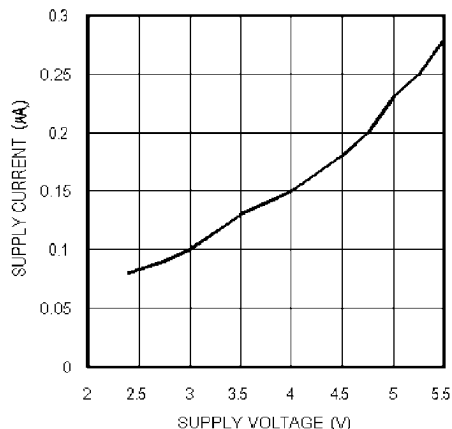

20107321

Application Information

GENERAL AMPLIFIER FUNCTION

The LM4671 features a filterless modulation scheme. The differential outputs of the device switch at 300kHz from V_{DD} to GND. When there is no input signal applied, the two outputs (V_{O1} and V_{O2}) switch with a 50% duty cycle, with both outputs in phase. Because the outputs of the LM4671 are differential, the two signals cancel each other. This results in no net voltage across the speaker, thus there is no load current during an idle state, conserving power.

With an input signal applied, the duty cycle (pulse width) of the LM4671 outputs changes. For increasing output voltages, the duty cycle of V_{O1} increases, while the duty cycle of V_{O2} decreases. For decreasing output voltages, the converse occurs, the duty cycle of V_{O2} increases while the duty cycle of V_{O1} decreases. The difference between the two pulse widths yields the differential output voltage.

POWER DISSIPATION AND EFFICIENCY

In general terms, efficiency is considered to be the ratio of useful work output divided by the total energy required to produce it with the difference being the power dissipated, typically, in the IC. The key here is "useful" work. For audio systems, the energy delivered in the audible bands is considered useful including the distortion products of the input signal. Sub-sonic (DC) and super-sonic components (>22kHz) are not useful. The difference between the power flowing from the power supply and the audio band power being transduced is dissipated in the LM4671 and in the transducer load. The amount of power dissipation in the LM4671 is very low. This is because the ON resistance of the switches used to form the output waveforms is typically less than 0.25Ω . This leaves only the transducer load as a potential "sink" for the small excess of input power over audio band output power. The LM4671 dissipates only a fraction of the excess power requiring no additional PCB area or copper plane to act as a heat sink.

DIFFERENTIAL AMPLIFIER EXPLANATION

As logic supply voltages continue to shrink, designers are increasingly turning to differential analog signal handling to preserve signal to noise ratios with restricted voltage swing.

The LM4671 is a fully differential amplifier that features differential input and output stages. A differential amplifier amplifies the difference between the two input signals. Traditional audio power amplifiers have typically offered only single-ended inputs resulting in a 6dB reduction in signal to noise ratio relative to differential inputs. The LM4671 also offers the possibility of DC input coupling which eliminates the two external AC coupling, DC blocking capacitors. The LM4671 can be used, however, as a single ended input amplifier while still retaining its fully differential benefits. In fact, completely unrelated signals may be placed on the input pins. The LM4671 simply amplifies the difference between the signals. A major benefit of a differential amplifier is the improved common mode rejection ratio (CMRR) over single input amplifiers. The common-mode rejection characteristic of the differential amplifier reduces sensitivity to ground offset related noise injection, especially important in high noise applications.

PCB LAYOUT CONSIDERATIONS

As output power increases, interconnect resistance (PCB traces and wires) between the amplifier, load and power supply create a voltage drop. The voltage loss on the traces between the LM4671 and the load results in lower output power and decreased efficiency. Higher trace resistance between the supply and the LM4671 has the same effect as a poorly regulated supply, increase ripple on the supply line also reducing the peak output power. The effects of residual trace resistance increases as output current increases due to higher output power, decreased load impedance or both. To maintain the highest output voltage swing and corresponding peak output power, the PCB traces that connect the output pins to the load and the supply pins to the power supply should be as wide as possible to minimize trace resistance.

The use of power and ground planes will give the best THD +N performance. While reducing trace resistance, the use of power planes also creates parasitic capacitors that help to filter the power supply line.

The inductive nature of the transducer load can also result in overshoot on one or both edges, clamped by the parasitic diodes to GND and V_{DD} in each case. From an EMI standpoint, this is an aggressive waveform that can radiate or conduct to other components in the system and cause inter-

ference. It is essential to keep the power and output traces short and well shielded if possible. Use of ground planes, beads, and micro-strip layout techniques are all useful in preventing unwanted interference.

As the distance from the LM4671 and the speaker increase, the amount of EMI radiation will increase since the output wires or traces acting as antenna become more efficient with length. What is acceptable EMI is highly application specific. Ferrite chip inductors placed close to the LM4671 may be needed to reduce EMI radiation. The value of the ferrite chip is very application specific.

POWER SUPPLY BYPASSING

As with any power amplifier, proper supply bypassing is critical for low noise performance and high power supply rejection ratio (PSRR). The capacitor (C_S) location should be as close as possible to the LM4671. Typical applications employ a voltage regulator with a $10\mu\text{F}$ and a $0.1\mu\text{F}$ bypass capacitors that increase supply stability. These capacitors do not eliminate the need for bypassing on the supply pin of the LM4671. A $1\mu\text{F}$ tantalum capacitor is recommended.

SHUTDOWN FUNCTION

In order to reduce power consumption while not in use, the LM4671 contains shutdown circuitry that reduces current draw to less than $0.01\mu\text{A}$. The trigger point for shutdown is shown as a typical value in the Electrical Characteristics Tables and in the Shutdown Hysteresis Voltage graphs found in the **Typical Performance Characteristics** section. It is best to switch between ground and supply for minimum current usage while in the shutdown state. While the LM4671 may be disabled with shutdown voltages in between ground and supply, the idle current will be greater than the typical $0.01\mu\text{A}$ value.

The LM4671 has an internal resistor connected between GND and Shutdown pins. The purpose of this resistor is to eliminate any unwanted state changes when the Shutdown pin is floating. The LM4671 will enter the shutdown state when the Shutdown pin is left floating or if not floating, when the shutdown voltage has crossed the threshold. To minimize the supply current while in the shutdown state, the Shutdown pin should be driven to GND or left floating. If the Shutdown pin is not driven to GND, the amount of additional resistor current due to the internal shutdown resistor can be found by Equation (1) below.

$$(V_{SD} - \text{GND}) / 60\text{k}\Omega \quad (1)$$

With only a 0.5V difference, an additional $8.3\mu\text{A}$ of current will be drawn while in the shutdown state.

PROPER SELECTION OF EXTERNAL COMPONENTS

The gain of the LM4671 is set by the external resistors, R_i in Figure 1, The Gain is given by Equation (2) below. Best THD +N performance is achieved with a gain of 2V/V (6dB).

$$A_V = 2 * 150 \text{ k}\Omega / R_i \text{ (V/V)} \quad (2)$$

It is recommended that resistors with 1% tolerance or better be used to set the gain of the LM4671. The R_i resistors should be placed close to the input pins of the LM4671. Keeping the input traces close to each other and of the same length in a high noise environment will aid in noise rejection due to the good CMRR of the LM4671. Noise coupled onto input traces

which are physically close to each other will be common mode and easily rejected by the LM4671.

Input capacitors may be needed for some applications or when the source is single-ended (see Figures 3, 5). Input capacitors are needed to block any DC voltage at the source so that the DC voltage seen between the input terminals of the LM4671 is 0V . Input capacitors create a high-pass filter with the input resistors, R_i . The -3dB point of the high-pass filter is found using Equation (3) below.

$$f_C = 1 / (2\pi R_i C_i) \text{ (Hz)} \quad (3)$$

The input capacitors may also be used to remove low audio frequencies. Small speakers cannot reproduce low bass frequencies so filtering may be desired. When the LM4671 is using a single-ended source, power supply noise on the ground is seen as an input signal by the +IN input pin that is capacitor coupled to ground (See Figures 5 – 7). Setting the high-pass filter point above the power supply noise frequencies, 217Hz in a GSM phone, for example, will filter out this noise so it is not amplified and heard on the output. Capacitors with a tolerance of 10% or better are recommended for impedance matching.

DIFFERENTIAL CIRCUIT CONFIGURATIONS

The LM4671 can be used in many different circuit configurations. The simplest and best performing is the DC coupled, differential input configuration shown in Figure 2. Equation (2) above is used to determine the value of the R_i resistors for a desired gain.

Input capacitors can be used in a differential configuration as shown in Figure 3. Equation (3) above is used to determine the value of the C_i capacitors for a desired frequency response due to the high-pass filter created by C_i and R_i . Equation (2) above is used to determine the value of the R_i resistors for a desired gain.

The LM4671 can be used to amplify more than one audio source. Figure 4 shows a dual differential input configuration. The gain for each input can be independently set for maximum design flexibility using the R_i resistors for each input and Equation (2). Input capacitors can be used with one or more sources as well to have different frequency responses depending on the source or if a DC voltage needs to be blocked from a source.

SINGLE-ENDED CIRCUIT CONFIGURATIONS

The LM4671 can also be used with single-ended sources but input capacitors will be needed to block any DC at the input terminals. Figure 5 shows the typical single-ended application configuration. The equations for Gain, Equation (2), and frequency response, Equation (3), hold for the single-ended configuration as shown in Figure 5.

When using more than one single-ended source as shown in Figure 6, the impedance seen from each input terminal should be equal. To find the correct values for C_{i3} and R_{i3} connected to the +IN input pin the equivalent impedance of all the single-ended sources are calculated. The single-ended sources are in parallel to each other. The equivalent capacitor and resistor, C_{i3} and R_{i3} , are found by calculating the parallel combination of all C_i values and then all R_i values. Equations (4) and (5) below are for any number of single-ended sources.

$$C_{i3} = C_{i1} + C_{i2} + C_{in} \dots (\mu\text{F}) \quad (4)$$

$$R_{i3} = 1 / (1/R_{i1} + 1/R_{i2} + 1/R_{in} \dots) (\Omega) \quad (5)$$

The LM4671 may also use a combination of single-ended and differential sources. A typical application with one single-end-

ed source and one differential source is shown in Figure 7. Using the principle of superposition, the external component values can be determined with the above equations corresponding to the configuration.

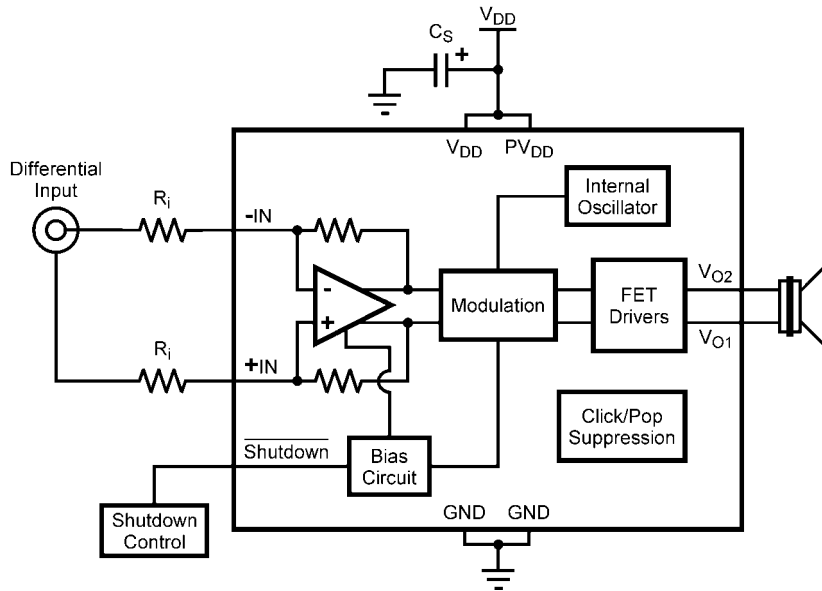

20107317

FIGURE 2. Differential input configuration

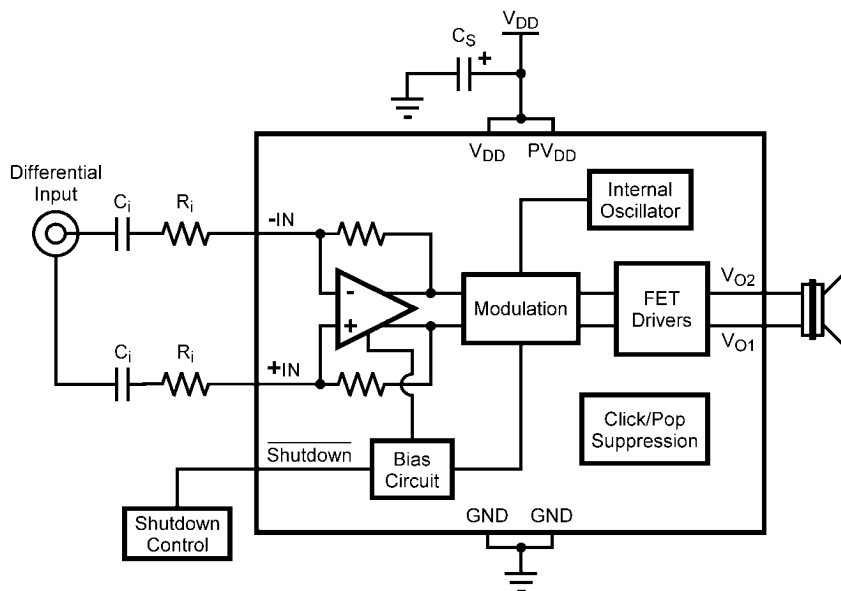

20107318

FIGURE 3. Differential input configuration with input capacitors

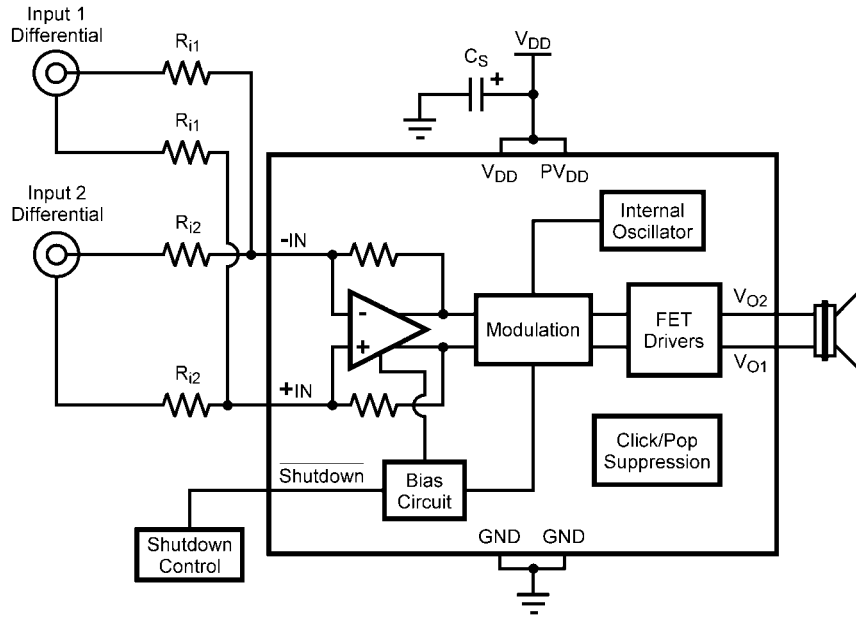

20107319

FIGURE 4. Dual differential input configuration

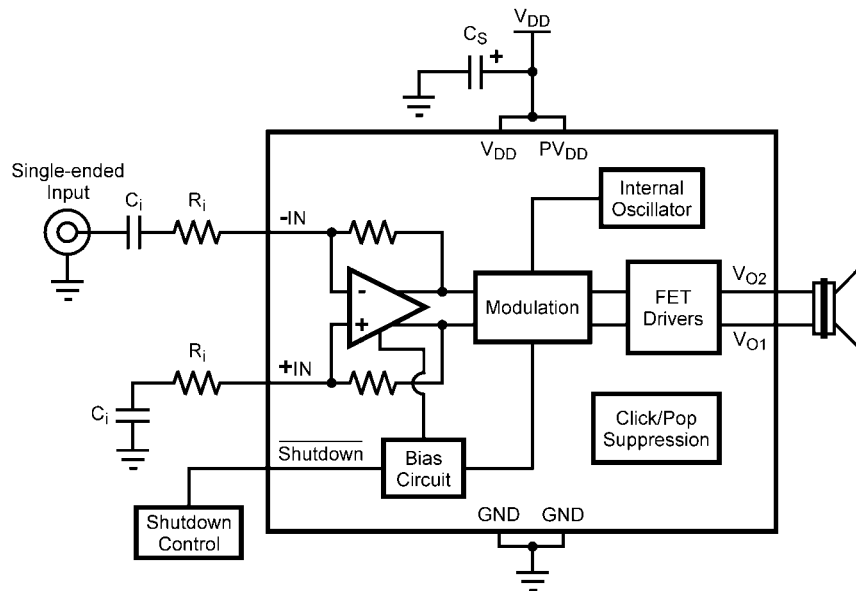

20107310

FIGURE 5. Single-ended input configuration

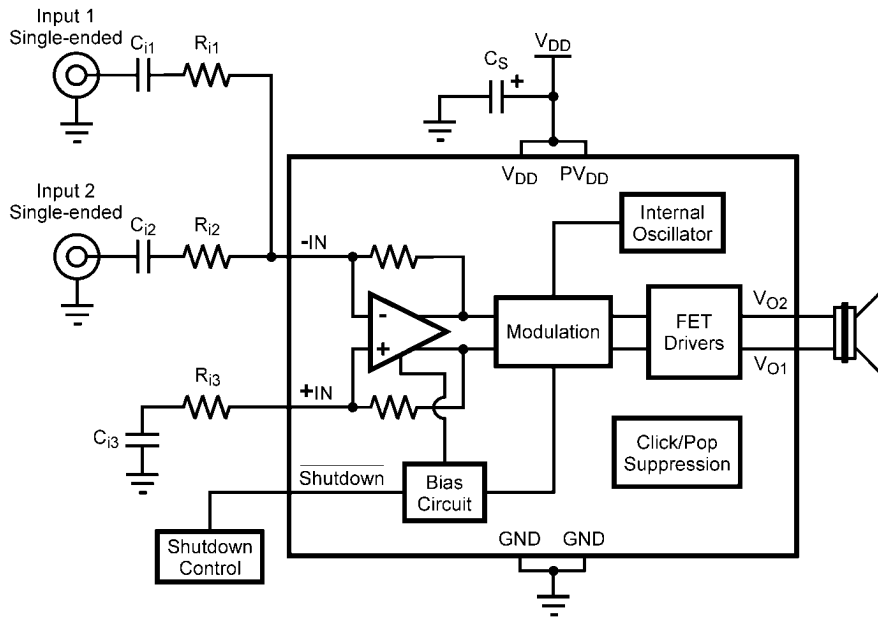

201073j1

FIGURE 6. Dual single-ended input configuration

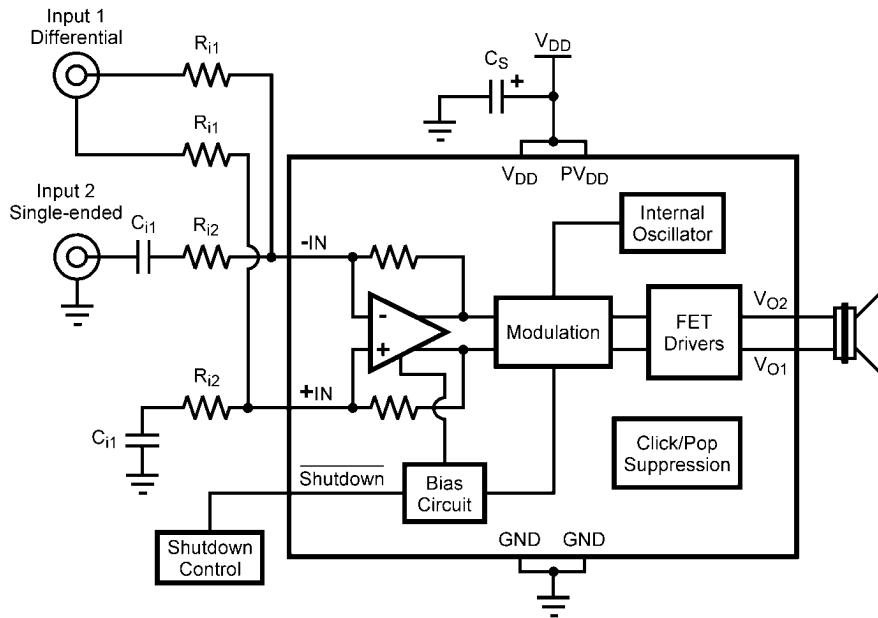

201073j2

FIGURE 7. Dual input with a single-ended input and a differential input

REFERENCE DESIGN BOARD SCHEMATIC

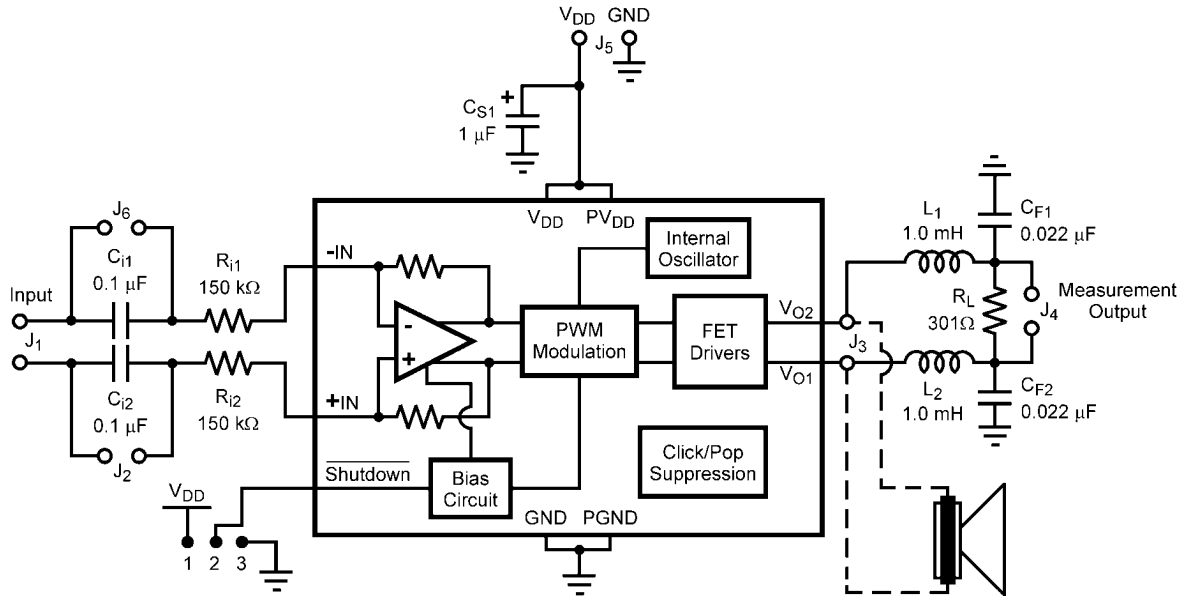

201073j4

FIGURE 8.

In addition to the minimal parts required for the application circuit, a measurement filter is provided on the evaluation circuit board so that conventional audio measurements can be conveniently made without additional equipment. This is a balanced input, grounded differential output low pass filter with a 3dB frequency of approximately 35kHz and an on board termination resistor of 300Ω (see schematic). Note that the capacitive load elements are returned to ground. This is not optimal for common mode rejection purposes, but due to the independent pulse format at each output there is a significant amount of high frequency common mode component on the outputs. The grounded capacitive filter elements attenuate this component at the board to reduce the high frequency CMRR requirement placed on the analysis instruments.

Even with the grounded filter the audio signal is still differential, necessitating a differential input on any analysis instrument connected to it. Most lab instruments that feature BNC connectors on their inputs are **NOT** differential responding because the ring of the BNC is usually grounded.

The commonly used Audio Precision analyzer is differential, but its ability to accurately reject high frequency signals is questionable necessitating the on board measurement filter. When in doubt or when the signal needs to be single-ended, use an audio signal transformer to convert the differential output to a single ended output. Depending on the audio transformer's characteristics, there may be some attenuation of the audio signal which needs to be taken into account for correct measurement of performance.

Measurements made at the output of the measurement filter suffer attenuation relative to the primary, unfiltered outputs even at audio frequencies. This is due to the resistance of the inductors interacting with the termination resistor (300Ω) and is typically about -0.25dB (3%). In other words, the voltage levels (and corresponding power levels) indicated through the measurement filter are slightly lower than those that actually occur at the load placed on the unfiltered outputs. This small loss in the filter for measurement gives a lower output power reading than what is really occurring on the unfiltered outputs and its load.

LM4671 micro SMD BOARD ARTWORK

Composite View

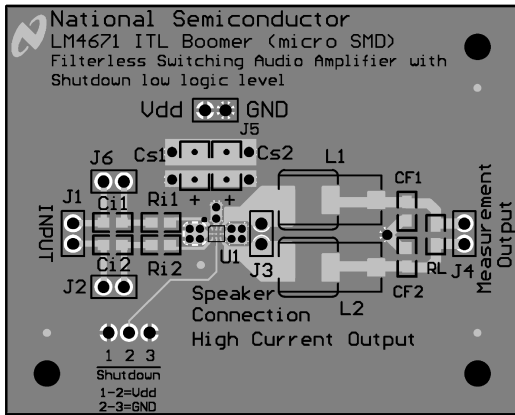

201073j6

Silk Screen

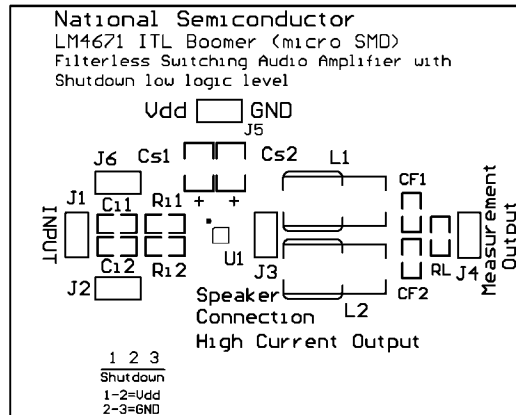

201073j9

Top Layer

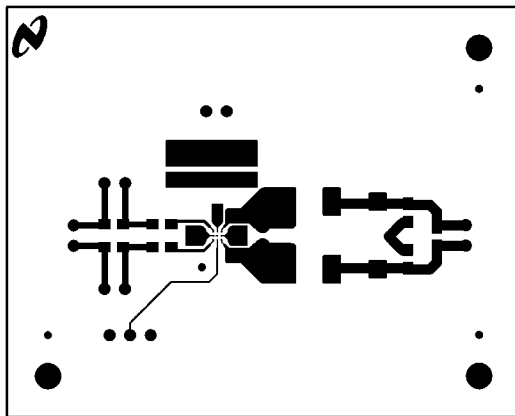

201073k0

Internal Layer 1, GND

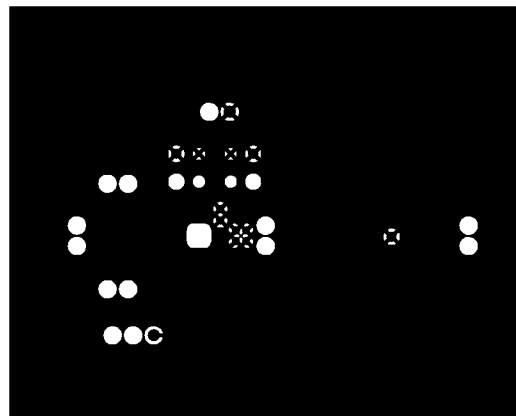

201073j7

Internal Layer 2, GND

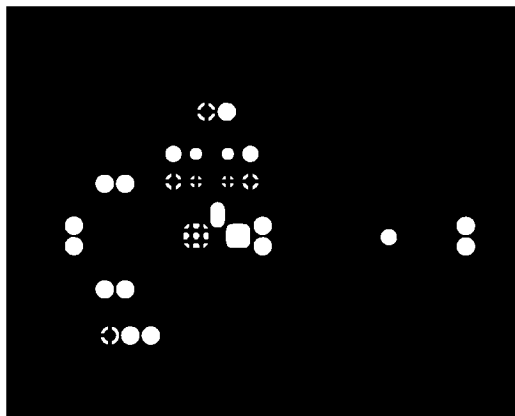

201073j8

Bottom Layer

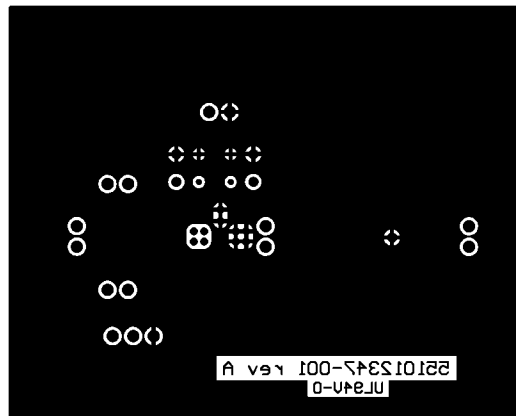

201073j5

Revision History

| Rev | Date | Description |
|------|----------|---|
| 1.0 | 03/16/05 | Initial release. |
| 1.01 | 12/17/07 | Some text edits. |
| 1.02 | 03/03/08 | Edited the SHUTDOWN FUNCTION section (under Application Information). |

Notes

For more National Semiconductor product information and proven design tools, visit the following Web sites at:

| Products | | Design Support | |
|--------------------------------|--|-------------------------|--|
| Amplifiers | www.national.com/amplifiers | WEBENCH | www.national.com/webench |
| Audio | www.national.com/audio | Analog University | www.national.com/AU |
| Clock Conditioners | www.national.com/timing | App Notes | www.national.com/appnotes |
| Data Converters | www.national.com/adc | Distributors | www.national.com/contacts |
| Displays | www.national.com/displays | Green Compliance | www.national.com/quality/green |
| Ethernet | www.national.com/ethernet | Packaging | www.national.com/packaging |
| Interface | www.national.com/interface | Quality and Reliability | www.national.com/quality |
| LVDS | www.national.com/lvds | Reference Designs | www.national.com/refdesigns |
| Power Management | www.national.com/power | Feedback | www.national.com/feedback |
| Switching Regulators | www.national.com/switchers | | |
| LDOs | www.national.com/ldo | | |
| LED Lighting | www.national.com/led | | |
| PowerWise | www.national.com/powerwise | | |
| Serial Digital Interface (SDI) | www.national.com/sdi | | |
| Temperature Sensors | www.national.com/tempsensors | | |
| Wireless (PLL/VCO) | www.national.com/wireless | | |

THE CONTENTS OF THIS DOCUMENT ARE PROVIDED IN CONNECTION WITH NATIONAL SEMICONDUCTOR CORPORATION ("NATIONAL") PRODUCTS. NATIONAL MAKES NO REPRESENTATIONS OR WARRANTIES WITH RESPECT TO THE ACCURACY OR COMPLETENESS OF THE CONTENTS OF THIS PUBLICATION AND RESERVES THE RIGHT TO MAKE CHANGES TO SPECIFICATIONS AND PRODUCT DESCRIPTIONS AT ANY TIME WITHOUT NOTICE. NO LICENSE, WHETHER EXPRESS, IMPLIED, ARISING BY ESTOPPEL OR OTHERWISE, TO ANY INTELLECTUAL PROPERTY RIGHTS IS GRANTED BY THIS DOCUMENT.

TESTING AND OTHER QUALITY CONTROLS ARE USED TO THE EXTENT NATIONAL DEEMS NECESSARY TO SUPPORT NATIONAL'S PRODUCT WARRANTY. EXCEPT WHERE MANDATED BY GOVERNMENT REQUIREMENTS, TESTING OF ALL PARAMETERS OF EACH PRODUCT IS NOT NECESSARILY PERFORMED. NATIONAL ASSUMES NO LIABILITY FOR APPLICATIONS ASSISTANCE OR BUYER PRODUCT DESIGN. BUYERS ARE RESPONSIBLE FOR THEIR PRODUCTS AND APPLICATIONS USING NATIONAL COMPONENTS. PRIOR TO USING OR DISTRIBUTING ANY PRODUCTS THAT INCLUDE NATIONAL COMPONENTS, BUYERS SHOULD PROVIDE ADEQUATE DESIGN, TESTING AND OPERATING SAFEGUARDS.

EXCEPT AS PROVIDED IN NATIONAL'S TERMS AND CONDITIONS OF SALE FOR SUCH PRODUCTS, NATIONAL ASSUMES NO LIABILITY WHATSOEVER, AND NATIONAL DISCLAIMS ANY EXPRESS OR IMPLIED WARRANTY RELATING TO THE SALE AND/OR USE OF NATIONAL PRODUCTS INCLUDING LIABILITY OR WARRANTIES RELATING TO FITNESS FOR A PARTICULAR PURPOSE, MERCHANTABILITY, OR INFRINGEMENT OF ANY PATENT, COPYRIGHT OR OTHER INTELLECTUAL PROPERTY RIGHT.

LIFE SUPPORT POLICY

NATIONAL'S PRODUCTS ARE NOT AUTHORIZED FOR USE AS CRITICAL COMPONENTS IN LIFE SUPPORT DEVICES OR SYSTEMS WITHOUT THE EXPRESS PRIOR WRITTEN APPROVAL OF THE CHIEF EXECUTIVE OFFICER AND GENERAL COUNSEL OF NATIONAL SEMICONDUCTOR CORPORATION. As used herein:

Life support devices or systems are devices which (a) are intended for surgical implant into the body, or (b) support or sustain life and whose failure to perform when properly used in accordance with instructions for use provided in the labeling can be reasonably expected to result in a significant injury to the user. A critical component is any component in a life support device or system whose failure to perform can be reasonably expected to cause the failure of the life support device or system or to affect its safety or effectiveness.

National Semiconductor and the National Semiconductor logo are registered trademarks of National Semiconductor Corporation. All other brand or product names may be trademarks or registered trademarks of their respective holders.

Copyright© 2008 National Semiconductor Corporation

For the most current product information visit us at www.national.com



**National Semiconductor
Americas Technical
Support Center**
Email:
new.feedback@nsc.com
Tel: 1-800-272-9959

**National Semiconductor Europe
Technical Support Center**
Email: europe.support@nsc.com
German Tel: +49 (0) 180 5010 771
English Tel: +44 (0) 870 850 4288

**National Semiconductor Asia
Pacific Technical Support Center**
Email: ap.support@nsc.com

**National Semiconductor Japan
Technical Support Center**
Email: jpn.feedback@nsc.com

IMPORTANT NOTICE

Texas Instruments Incorporated and its subsidiaries (TI) reserve the right to make corrections, modifications, enhancements, improvements, and other changes to its products and services at any time and to discontinue any product or service without notice. Customers should obtain the latest relevant information before placing orders and should verify that such information is current and complete. All products are sold subject to TI's terms and conditions of sale supplied at the time of order acknowledgment.

TI warrants performance of its hardware products to the specifications applicable at the time of sale in accordance with TI's standard warranty. Testing and other quality control techniques are used to the extent TI deems necessary to support this warranty. Except where mandated by government requirements, testing of all parameters of each product is not necessarily performed.

TI assumes no liability for applications assistance or customer product design. Customers are responsible for their products and applications using TI components. To minimize the risks associated with customer products and applications, customers should provide adequate design and operating safeguards.

TI does not warrant or represent that any license, either express or implied, is granted under any TI patent right, copyright, mask work right, or other TI intellectual property right relating to any combination, machine, or process in which TI products or services are used. Information published by TI regarding third-party products or services does not constitute a license from TI to use such products or services or a warranty or endorsement thereof. Use of such information may require a license from a third party under the patents or other intellectual property of the third party, or a license from TI under the patents or other intellectual property of TI.

Reproduction of TI information in TI data books or data sheets is permissible only if reproduction is without alteration and is accompanied by all associated warranties, conditions, limitations, and notices. Reproduction of this information with alteration is an unfair and deceptive business practice. TI is not responsible or liable for such altered documentation. Information of third parties may be subject to additional restrictions.

Resale of TI products or services with statements different from or beyond the parameters stated by TI for that product or service voids all express and any implied warranties for the associated TI product or service and is an unfair and deceptive business practice. TI is not responsible or liable for any such statements.

TI products are not authorized for use in safety-critical applications (such as life support) where a failure of the TI product would reasonably be expected to cause severe personal injury or death, unless officers of the parties have executed an agreement specifically governing such use. Buyers represent that they have all necessary expertise in the safety and regulatory ramifications of their applications, and acknowledge and agree that they are solely responsible for all legal, regulatory and safety-related requirements concerning their products and any use of TI products in such safety-critical applications, notwithstanding any applications-related information or support that may be provided by TI. Further, Buyers must fully indemnify TI and its representatives against any damages arising out of the use of TI products in such safety-critical applications.

TI products are neither designed nor intended for use in military/aerospace applications or environments unless the TI products are specifically designated by TI as military-grade or "enhanced plastic." Only products designated by TI as military-grade meet military specifications. Buyers acknowledge and agree that any such use of TI products which TI has not designated as military-grade is solely at the Buyer's risk, and that they are solely responsible for compliance with all legal and regulatory requirements in connection with such use.

TI products are neither designed nor intended for use in automotive applications or environments unless the specific TI products are designated by TI as compliant with ISO/TS 16949 requirements. Buyers acknowledge and agree that, if they use any non-designated products in automotive applications, TI will not be responsible for any failure to meet such requirements.

Following are URLs where you can obtain information on other Texas Instruments products and application solutions:

Products

| | |
|------------------------|--|
| Audio | www.ti.com/audio |
| Amplifiers | amplifier.ti.com |
| Data Converters | dataconverter.ti.com |
| DLP® Products | www.dlp.com |
| DSP | dsp.ti.com |
| Clocks and Timers | www.ti.com/clocks |
| Interface | interface.ti.com |
| Logic | logic.ti.com |
| Power Mgmt | power.ti.com |
| Microcontrollers | microcontroller.ti.com |
| RFID | www.ti-rfid.com |
| OMAP Mobile Processors | www.ti.com/omap |
| Wireless Connectivity | www.ti.com/wirelessconnectivity |

Applications

| | |
|-------------------------------|--|
| Communications and Telecom | www.ti.com/communications |
| Computers and Peripherals | www.ti.com/computers |
| Consumer Electronics | www.ti.com/consumer-apps |
| Energy and Lighting | www.ti.com/energy |
| Industrial | www.ti.com/industrial |
| Medical | www.ti.com/medical |
| Security | www.ti.com/security |
| Space, Avionics and Defense | www.ti.com/space-avionics-defense |
| Transportation and Automotive | www.ti.com/automotive |
| Video and Imaging | www.ti.com/video |

TI E2E Community Home Page

e2e.ti.com

Mailing Address: Texas Instruments, Post Office Box 655303, Dallas, Texas 75265
Copyright © 2011, Texas Instruments Incorporated

www.BDTIC.com/TI