

- **Low Noise**
- **No External Components Required**
- **Replace Chopper Amplifiers at a Lower Cost**
- **Wide Input-Voltage Range**
... 0 to ± 14 V Typ
- **Wide Supply-Voltage Range**
... ± 3 V to ± 18 V

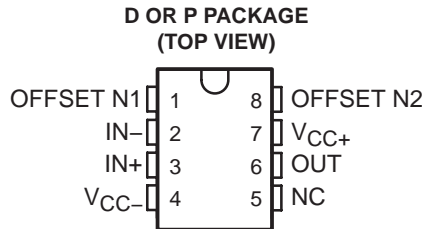

NC – No internal connection

description/ordering information

These devices offer low offset and long-term stability by means of a low-noise, chopperless, bipolar-input-transistor amplifier circuit. For most applications, external components are not required for offset nulling and frequency compensation. The true differential input, with a wide input-voltage range and outstanding common-mode rejection, provides maximum flexibility and performance in high-noise environments and in noninverting applications. Low bias currents and extremely high input impedances are maintained over the entire temperature range. The OP07 is unsurpassed for low-noise, high-accuracy amplification of very-low-level signals.

These devices are characterized for operation from 0°C to 70°C.

ORDERING INFORMATION

T_A	PACKAGE†		ORDERABLE PART NUMBER	TOP-SIDE MARKING
0°C to 70°C	PDIP (P)	Tube of 50	OP07CP	OP07CP
		Tube of 50	OP07DP	OP07DP
	SOIC (D)	Tube of 75	OP07CD	OP07C
		Reel of 2500	OP07CDR	
		Tube of 75	OP07DD	OP07D
		Reel of 2500	OP07DDR	

† Package drawings, standard packing quantities, thermal data, symbolization, and PCB design guidelines are available at www.ti.com/sc/package.

symbol

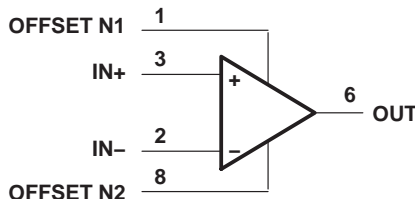

Please be aware that an important notice concerning availability, standard warranty, and use in critical applications of Texas Instruments semiconductor products and disclaimers thereto appears at the end of this data sheet.

PRODUCTION DATA information is current as of publication date. Products conform to specifications per the terms of Texas Instruments standard warranty. Production processing does not necessarily include testing of all parameters.

Copyright © 2004, Texas Instruments Incorporated

OP07C, OP07D PRECISION OPERATIONAL AMPLIFIERS

SLOS099E – OCTOBER 1983 – REVISED MAY 2004

schematic

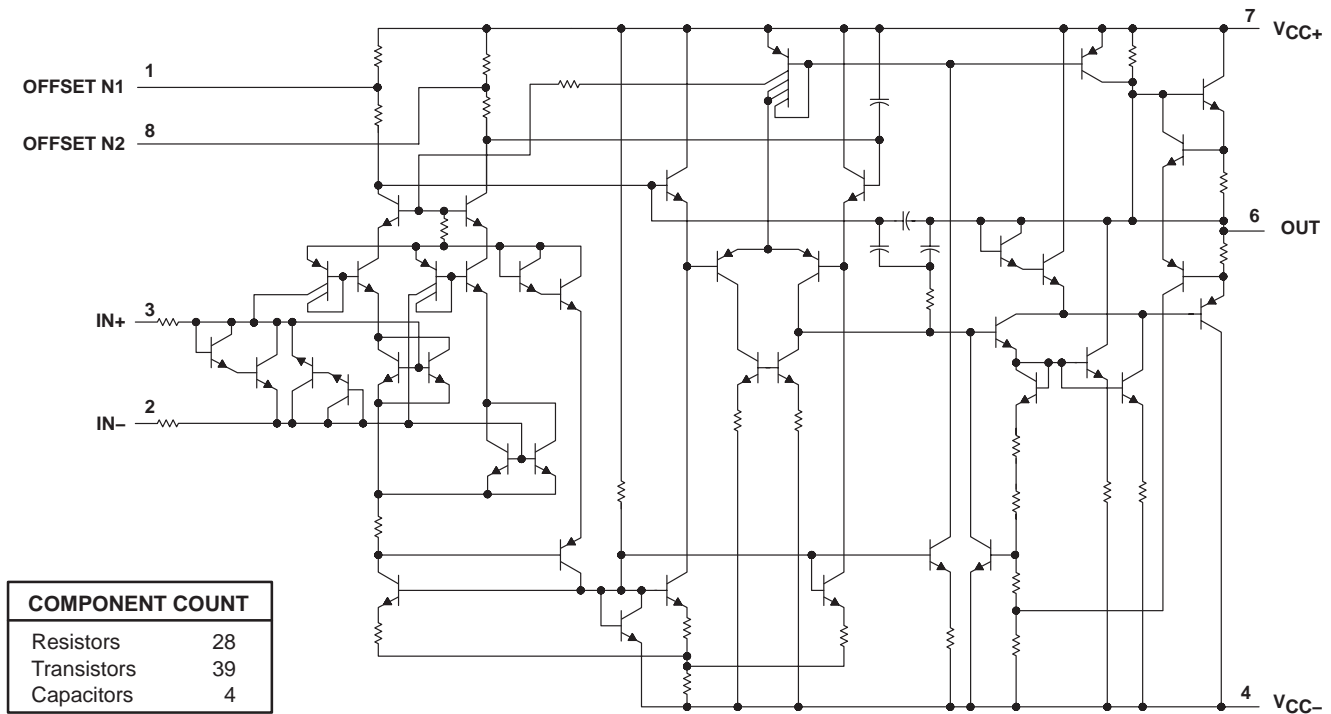

absolute maximum ratings over operating free-air temperature range (unless otherwise noted)†

Supply voltage: V_{CC+} (see Note 1)	22 V
V_{CC-} (see Note 1)	-22 V
Differential input voltage (see Note 2)	± 30 V
Input voltage, V_I (either input, see Note 3)	± 22 V
Duration of output short circuit (see Note 4)	Unlimited
Package thermal impedance, θ_{JA} (see Notes 5 and 6): D package	97°C/W
P package	85°C/W
Operating virtual junction temperature, T_J	150°C
Lead temperature 1,6 mm (1/16 inch) from case for 10 seconds	260°C
Storage temperature range, T_{stg}	-65°C to 150°C

† Stresses beyond those listed under “absolute maximum ratings” may cause permanent damage to the device. These are stress ratings only, and functional operation of the device at these or any other conditions beyond those indicated under “recommended operating conditions” is not implied. Exposure to absolute-maximum-rated conditions for extended periods may affect device reliability.

NOTES: 1. All voltage values, unless otherwise noted, are with respect to the midpoint between V_{CC+} and V_{CC-} .

2. Differential voltages are at $IN+$ with respect to $IN-$.

3. The magnitude of the input voltage must never exceed the magnitude of the supply voltage or 15 V, whichever is less.

4. The output may be shorted to ground or to either power supply.

5. Maximum power dissipation is a function of $T_J(max)$, θ_{JA} , and T_A . The maximum allowable power dissipation at any allowable ambient temperature is $P_D = (T_J(max) - T_A)/\theta_{JA}$. Selecting the maximum of 150°C can affect reliability.

6. The package thermal impedance is calculated in accordance with JESD 51-7.

OP07C, OP07D PRECISION OPERATIONAL AMPLIFIERS

SLOS099E – OCTOBER 1983 – REVISED MAY 2004

recommended operating conditions

		MIN	MAX	UNIT
$V_{CC\pm}$	Supply voltage	± 3	± 18	V
V_{IC}	Common-mode input voltage	-13	13	V
		$V_{CC\pm} = \pm 15$ V		
T_A	Operating free-air temperature	0	70	$^{\circ}\text{C}$

OP07C, OP97D
PRECISION OPERATIONAL AMPLIFIERS

SLOS099E – OCTOBER 1983 – REVISED MAY 2004

electrical characteristics at specified free-air temperature, $V_{CC\pm} = \pm 15\text{ V}$ (unless otherwise noted)

PARAMETER	TEST CONDITION†	TA	OP07C			OP07D			UNIT
			MIN	TYP	MAX	MIN	TYP	MAX	
V_{IO} Input offset voltage	$V_O = 0$, $R_S = 50\ \Omega$	25°C	60	150	60	150	60	150	μV
$\alpha_{V_{IO}}$ Temperature coefficient of input offset voltage	$V_O = 0$, $R_S = 50\ \Omega$	0°C to 70°C	85	250	85	250	85	250	$\mu\text{V}/^\circ\text{C}$
Long-term drift of input offset voltage	See Note 6	0°C to 70°C	0.5	1.8	0.7	2.5	0.7	2.5	$\mu\text{V}/\text{mo}$
Offset adjustment range	$R_S = 20\ \text{k}\Omega$, See Figure 1	25°C	±4			±4			mV
I_{IO} Input offset current		25°C	0.8	6	0.8	6	0.8	6	nA
$\alpha_{I_{IO}}$ Temperature coefficient of input offset current		0°C to 70°C	1.6	8	1.6	8	1.6	8	nA
I_{IB} Input bias current		0°C to 70°C	12	50	12	50	12	50	pA/°C
$\alpha_{I_{IB}}$ Temperature coefficient of input bias current		25°C	±1.8	±7	±2	±12	±2	±12	nA
V_{ICR} Common-mode input voltage range		0°C to 70°C	±2.2	±9	±3	±14	±3	±14	pA/°C
V_{OM} Peak output voltage		0°C to 70°C	18	50	18	50	18	50	pA/°C
	$R_L \geq 10\ \text{k}\Omega$	25°C	±13	±14	±13	±14	±13	±14	V
	$R_L \geq 2\ \text{k}\Omega$	0°C to 70°C	±13	±13.5	±13	±13.5	±13	±13.5	V
	$R_L \geq 1\ \text{k}\Omega$	25°C	±12	±13	±12	±13	±12	±13	V
A/D Large-signal differential voltage amplification	$R_L \geq 2\ \text{k}\Omega$	25°C	±11.5	±12.8	±11.5	±12.8	±11.5	±12.8	V
	$R_L \geq 1\ \text{k}\Omega$	0°C to 70°C	±12	±12.6	±12	±12.6	±12	±12.6	V
	$V_{CC\pm} = \pm 3\text{ V}$, $V_O = \pm 0.5\text{ V}$, $R_L \geq 500\ \text{k}\Omega$	25°C	100	400	400	400	400	400	V/mV
B_1 Unity-gain bandwidth	$V_O = \pm 10\text{ V}$, $R_L = 2\ \text{k}\Omega$	25°C	120	400	120	400	120	400	MHz
r_i Input resistance		0°C to 70°C	100	400	100	400	100	400	M Ω
CMRR Common-mode rejection ratio		25°C	0.4	0.6	0.4	0.6	0.4	0.6	M Ω
kSVS Supply-voltage sensitivity ($\Delta V_{IO}/\Delta V_{CC}$)	$V_{IC} = \pm 13\text{ V}$, $R_S = 50\ \Omega$	25°C	8	33	7	31	7	31	M Ω
PD Power dissipation	$V_{CC\pm} = \pm 3\text{ V}$ to $\pm 18\text{ V}$, $R_S = 50\ \Omega$	25°C	100	120	94	110	94	110	dB
	$V_O = 0$, No load	0°C to 70°C	97	120	94	106	94	106	dB
Power dissipation	$V_{CC\pm} = \pm 3\text{ V}$, $V_O = 0$, No load	25°C	7	32	7	32	7	32	$\mu\text{V}/\text{V}$
		0°C to 70°C	10	51	10	51	10	51	$\mu\text{V}/\text{V}$
Power dissipation	$V_O = 0$, No load	25°C	80	150	80	150	80	150	mW
	$V_{CC\pm} = \pm 3\text{ V}$, $V_O = 0$, No load	25°C	4	8	4	8	4	8	mW

† All characteristics are measured under open-loop conditions, with zero common-mode input voltage, unless otherwise noted.
 NOTE 7: Since long-term drift cannot be measured on the individual devices prior to shipment, this specification is not intended to be a warranty. It is an engineering estimate of the averaged trend line of drift versus time over extended periods after the first 30 days of operation.

operating characteristics, $V_{CC\pm} = \pm 15\text{ V}$, $T_A = 25^\circ\text{C}$

PARAMETER	TEST CONDITIONS†	OP07C	OP07D	UNIT
		TYP	TYP	
V_n Equivalent input noise voltage	$f = 10\text{ Hz}$	10.5	10.5	$\text{nV}/\sqrt{\text{Hz}}$
	$f = 100\text{ Hz}$	10.2	10.3	
	$f = 1\text{ kHz}$	9.8	9.8	
$V_{N(PP)}$ Peak-to-peak equivalent input noise voltage	$f = 0.1\text{ Hz to }10\text{ Hz}$	0.38	0.38	μV
I_n Equivalent input noise current	$f = 10\text{ Hz}$	0.35	0.35	$\text{pA}/\sqrt{\text{Hz}}$
	$f = 100\text{ Hz}$	0.15	0.15	
	$f = 1\text{ kHz}$	0.13	0.13	
$I_{N(PP)}$ Peak-to-peak equivalent input noise current	$f = 0.1\text{ Hz to }10\text{ Hz}$	15	15	pA
SR Slew rate	$R_L \geq 2\text{ k}\Omega$	0.3	0.3	$\text{V}/\mu\text{s}$

† All characteristics are measured under open-loop conditions, with zero common-mode input voltage, unless otherwise noted.

APPLICATION INFORMATION

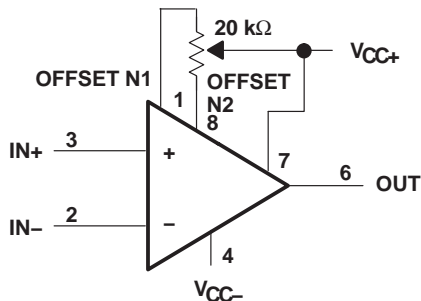

Figure 1. Input Offset-Voltage Null Circuit

PACKAGING INFORMATION

Orderable Device	Status ⁽¹⁾	Package Type	Package Drawing	Pins	Package Qty	Eco Plan ⁽²⁾	Lead/ Ball Finish	MSL Peak Temp ⁽³⁾	Samples (Requires Login)
OP-07DPSR	ACTIVE	SO	PS	8	2000	Green (RoHS & no Sb/Br)	CU NIPDAU	Level-1-260C-UNLIM	
OP-07DPSRE4	ACTIVE	SO	PS	8	2000	Green (RoHS & no Sb/Br)	CU NIPDAU	Level-1-260C-UNLIM	
OP-07DPSRG4	ACTIVE	SO	PS	8	2000	Green (RoHS & no Sb/Br)	CU NIPDAU	Level-1-260C-UNLIM	
OP07CD	ACTIVE	SOIC	D	8	75	Green (RoHS & no Sb/Br)	CU NIPDAU	Level-1-260C-UNLIM	
OP07CDE4	ACTIVE	SOIC	D	8	75	Green (RoHS & no Sb/Br)	CU NIPDAU	Level-1-260C-UNLIM	
OP07CDG4	ACTIVE	SOIC	D	8	75	Green (RoHS & no Sb/Br)	CU NIPDAU	Level-1-260C-UNLIM	
OP07CDR	ACTIVE	SOIC	D	8	2500	Green (RoHS & no Sb/Br)	CU NIPDAU	Level-1-260C-UNLIM	
OP07CDRE4	ACTIVE	SOIC	D	8	2500	Green (RoHS & no Sb/Br)	CU NIPDAU	Level-1-260C-UNLIM	
OP07CDRG4	ACTIVE	SOIC	D	8	2500	Green (RoHS & no Sb/Br)	CU NIPDAU	Level-1-260C-UNLIM	
OP07CP	ACTIVE	PDIP	P	8	50	Pb-Free (RoHS)	CU NIPDAU	N / A for Pkg Type	
OP07CPE4	ACTIVE	PDIP	P	8	50	Pb-Free (RoHS)	CU NIPDAU	N / A for Pkg Type	
OP07DD	ACTIVE	SOIC	D	8	75	Green (RoHS & no Sb/Br)	CU NIPDAU	Level-1-260C-UNLIM	
OP07DDE4	ACTIVE	SOIC	D	8	75	Green (RoHS & no Sb/Br)	CU NIPDAU	Level-1-260C-UNLIM	
OP07DDG4	ACTIVE	SOIC	D	8	75	Green (RoHS & no Sb/Br)	CU NIPDAU	Level-1-260C-UNLIM	
OP07DDR	ACTIVE	SOIC	D	8	2500	Green (RoHS & no Sb/Br)	CU NIPDAU	Level-1-260C-UNLIM	
OP07DDRE4	ACTIVE	SOIC	D	8	2500	Green (RoHS & no Sb/Br)	CU NIPDAU	Level-1-260C-UNLIM	
OP07DDRG4	ACTIVE	SOIC	D	8	2500	Green (RoHS & no Sb/Br)	CU NIPDAU	Level-1-260C-UNLIM	
OP07DP	ACTIVE	PDIP	P	8	50	Pb-Free (RoHS)	CU NIPDAU	N / A for Pkg Type	

Orderable Device	Status ⁽¹⁾	Package Type	Package Drawing	Pins	Package Qty	Eco Plan ⁽²⁾	Lead/ Ball Finish	MSL Peak Temp ⁽³⁾	Samples (Requires Login)
OP07DPE4	ACTIVE	PDIP	P	8	50	Pb-Free (RoHS)	CU NIPDAU	N / A for Pkg Type	

⁽¹⁾ The marketing status values are defined as follows:

ACTIVE: Product device recommended for new designs.

LIFEBUY: TI has announced that the device will be discontinued, and a lifetime-buy period is in effect.

NRND: Not recommended for new designs. Device is in production to support existing customers, but TI does not recommend using this part in a new design.

PREVIEW: Device has been announced but is not in production. Samples may or may not be available.

OBSELETE: TI has discontinued the production of the device.

⁽²⁾ Eco Plan - The planned eco-friendly classification: Pb-Free (RoHS), Pb-Free (RoHS Exempt), or Green (RoHS & no Sb/Br) - please check <http://www.ti.com/productcontent> for the latest availability information and additional product content details.

TBD: The Pb-Free/Green conversion plan has not been defined.

Pb-Free (RoHS): TI's terms "Lead-Free" or "Pb-Free" mean semiconductor products that are compatible with the current RoHS requirements for all 6 substances, including the requirement that lead not exceed 0.1% by weight in homogeneous materials. Where designed to be soldered at high temperatures, TI Pb-Free products are suitable for use in specified lead-free processes.

Pb-Free (RoHS Exempt): This component has a RoHS exemption for either 1) lead-based flip-chip solder bumps used between the die and package, or 2) lead-based die adhesive used between the die and leadframe. The component is otherwise considered Pb-Free (RoHS compatible) as defined above.

Green (RoHS & no Sb/Br): TI defines "Green" to mean Pb-Free (RoHS compatible), and free of Bromine (Br) and Antimony (Sb) based flame retardants (Br or Sb do not exceed 0.1% by weight in homogeneous material)

⁽³⁾ MSL, Peak Temp. -- The Moisture Sensitivity Level rating according to the JEDEC industry standard classifications, and peak solder temperature.

Important Information and Disclaimer: The information provided on this page represents TI's knowledge and belief as of the date that it is provided. TI bases its knowledge and belief on information provided by third parties, and makes no representation or warranty as to the accuracy of such information. Efforts are underway to better integrate information from third parties. TI has taken and continues to take reasonable steps to provide representative and accurate information but may not have conducted destructive testing or chemical analysis on incoming materials and chemicals. TI and TI suppliers consider certain information to be proprietary, and thus CAS numbers and other limited information may not be available for release.

In no event shall TI's liability arising out of such information exceed the total purchase price of the TI part(s) at issue in this document sold by TI to Customer on an annual basis.

TAPE AND REEL INFORMATION



QUADRANT ASSIGNMENTS FOR PIN 1 ORIENTATION IN TAPE



*All dimensions are nominal

Device	Package Type	Package Drawing	Pins	SPQ	Reel Diameter (mm)	Reel Width W1 (mm)	A0 (mm)	B0 (mm)	K0 (mm)	P1 (mm)	W (mm)	Pin1 Quadrant
OP-07DPSR	SO	PS	8	2000	330.0	16.4	8.2	6.6	2.5	12.0	16.0	Q1
OP07CDR	SOIC	D	8	2500	330.0	12.4	6.4	5.2	2.1	8.0	12.0	Q1
OP07DDR	SOIC	D	8	2500	330.0	12.4	6.4	5.2	2.1	8.0	12.0	Q1

TAPE AND REEL BOX DIMENSIONS



*All dimensions are nominal

Device	Package Type	Package Drawing	Pins	SPQ	Length (mm)	Width (mm)	Height (mm)
OP-07DPSR	SO	PS	8	2000	346.0	346.0	33.0
OP07CDR	SOIC	D	8	2500	340.5	338.1	20.6
OP07DDR	SOIC	D	8	2500	340.5	338.1	20.6

P (R-PDIP-T8)

PLASTIC DUAL-IN-LINE PACKAGE

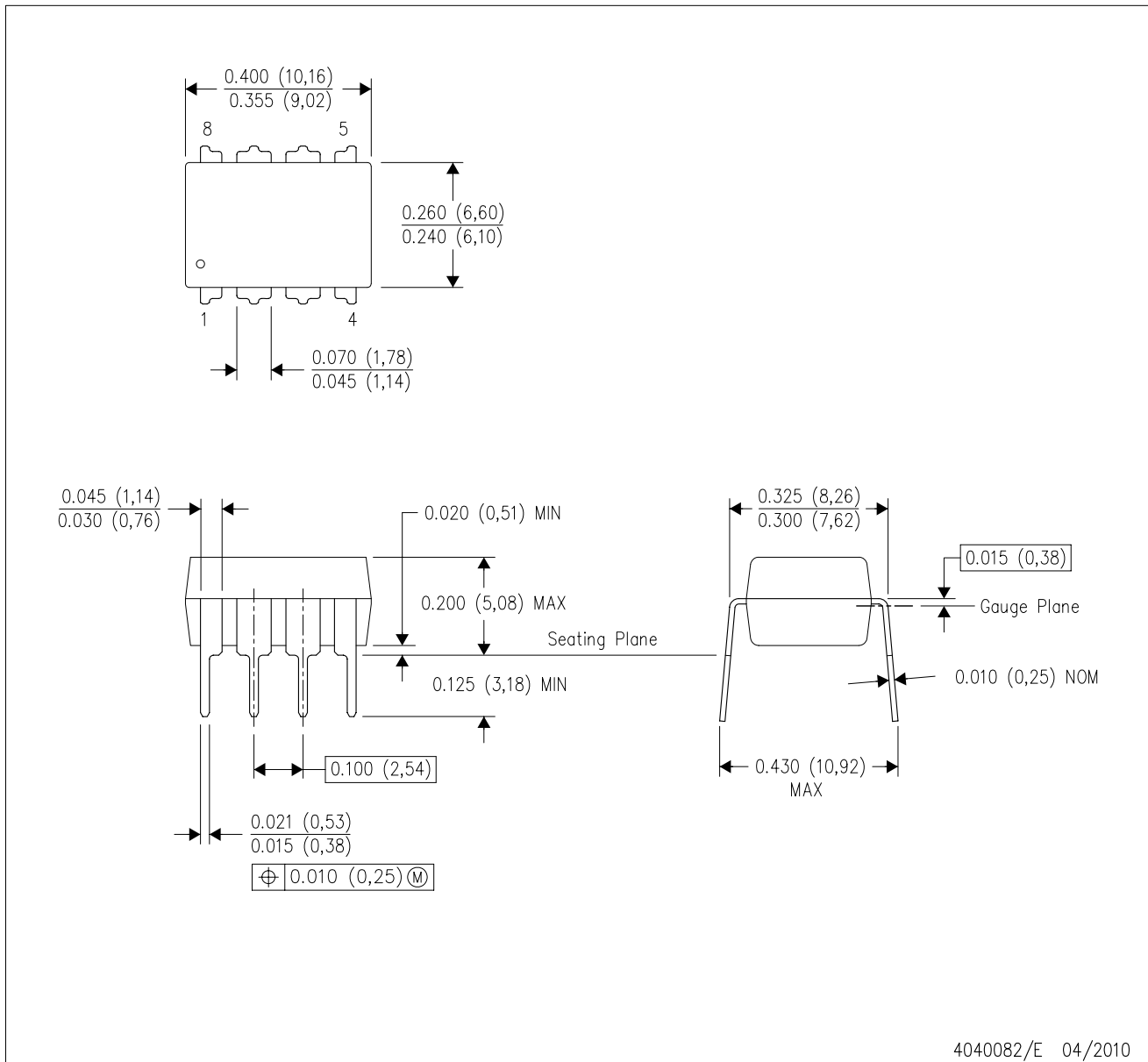

- NOTES:
- A. All linear dimensions are in inches (millimeters).
 - B. This drawing is subject to change without notice.
 - C. Falls within JEDEC MS-001 variation BA.

D (R-PDSO-G8)

PLASTIC SMALL OUTLINE

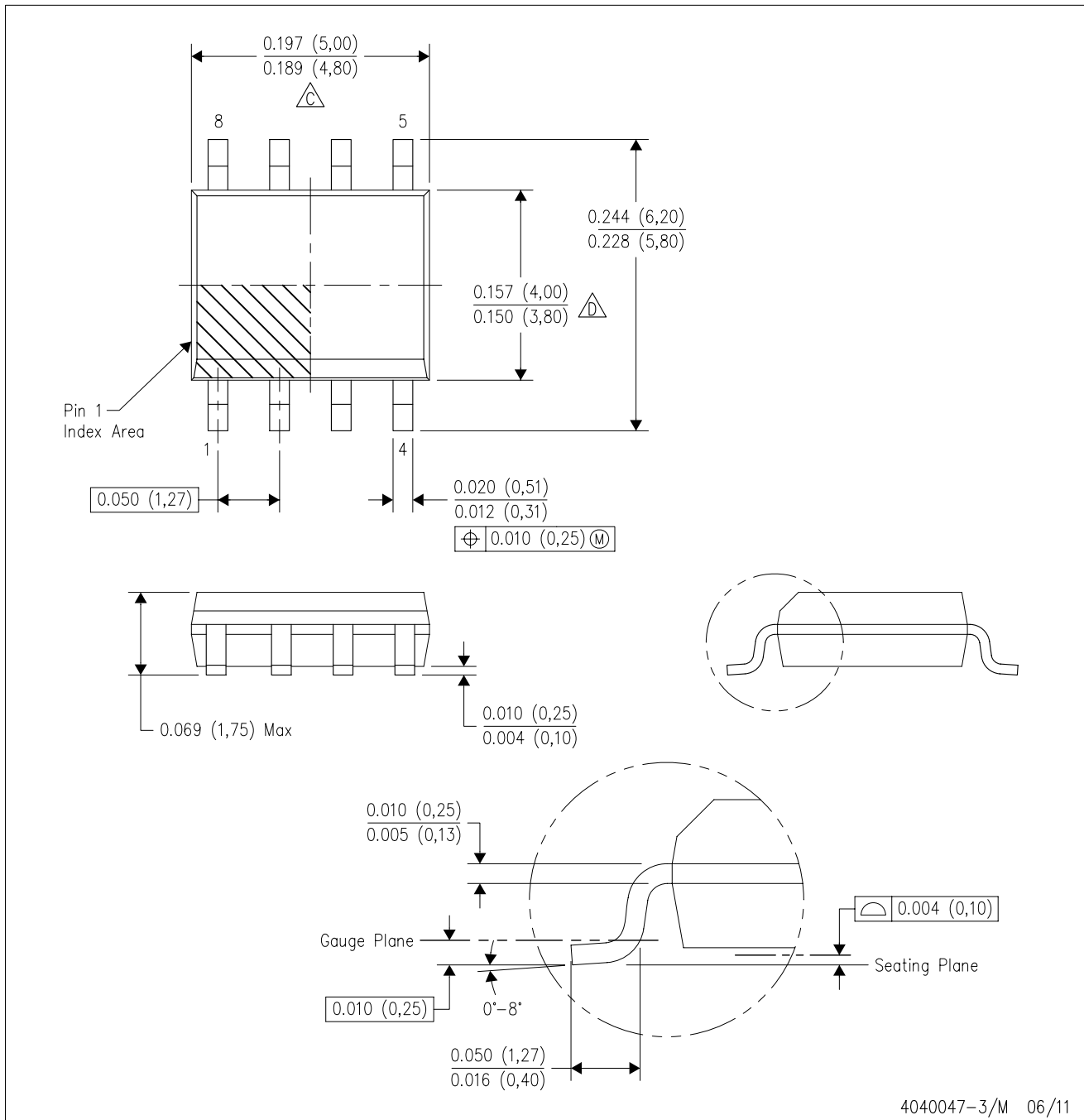

- NOTES:
- A. All linear dimensions are in inches (millimeters).
 - B. This drawing is subject to change without notice.
 - △ Body length does not include mold flash, protrusions, or gate burrs. Mold flash, protrusions, or gate burrs shall not exceed 0.006 (0,15) each side.
 - △ Body width does not include interlead flash. Interlead flash shall not exceed 0.017 (0,43) each side.
 - E. Reference JEDEC MS-012 variation AA.

D (R-PDSO-G8)

PLASTIC SMALL OUTLINE

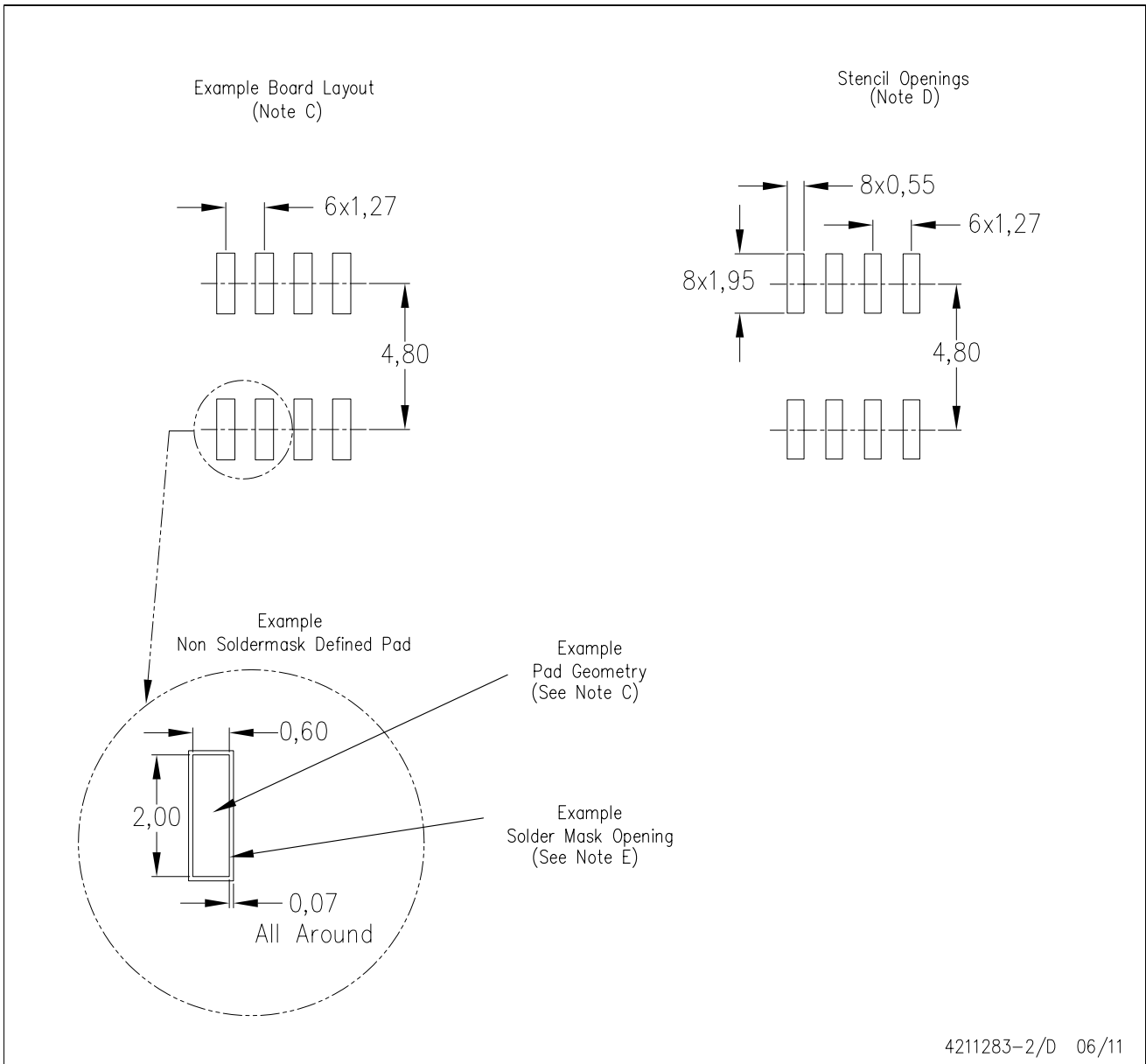

4211283-2/D 06/11

- NOTES:
- A. All linear dimensions are in millimeters.
 - B. This drawing is subject to change without notice.
 - C. Publication IPC-7351 is recommended for alternate designs.
 - D. Laser cutting apertures with trapezoidal walls and also rounding corners will offer better paste release. Customers should contact their board assembly site for stencil design recommendations. Refer to IPC-7525 for other stencil recommendations.
 - E. Customers should contact their board fabrication site for solder mask tolerances between and around signal pads.

MECHANICAL DATA

PS (R-PDSO-G8)

PLASTIC SMALL-OUTLINE PACKAGE

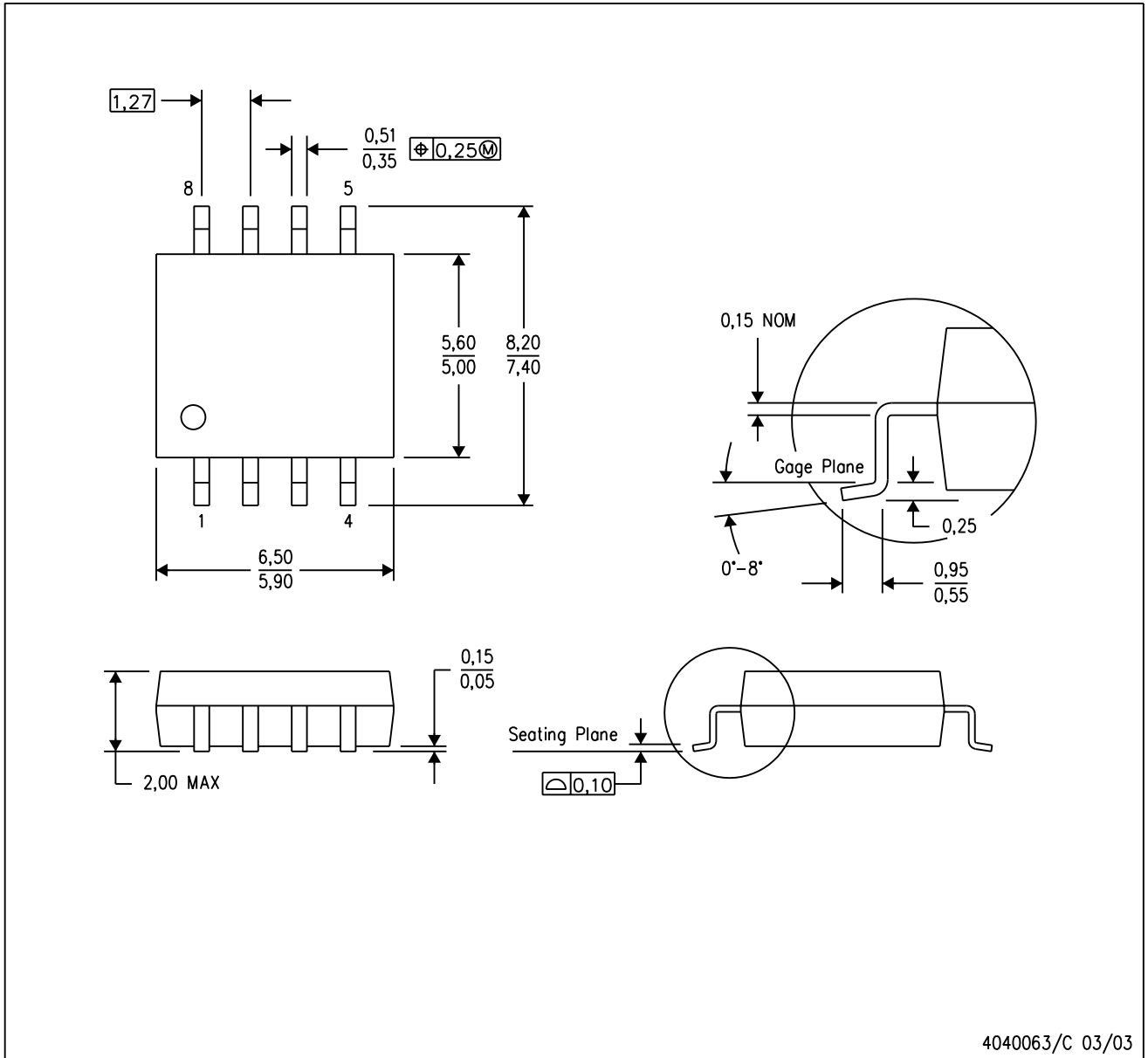

- NOTES:
- A. All linear dimensions are in millimeters.
 - B. This drawing is subject to change without notice.
 - C. Body dimensions do not include mold flash or protrusion, not to exceed 0,15.

IMPORTANT NOTICE

Texas Instruments Incorporated and its subsidiaries (TI) reserve the right to make corrections, modifications, enhancements, improvements, and other changes to its products and services at any time and to discontinue any product or service without notice. Customers should obtain the latest relevant information before placing orders and should verify that such information is current and complete. All products are sold subject to TI's terms and conditions of sale supplied at the time of order acknowledgment.

TI warrants performance of its hardware products to the specifications applicable at the time of sale in accordance with TI's standard warranty. Testing and other quality control techniques are used to the extent TI deems necessary to support this warranty. Except where mandated by government requirements, testing of all parameters of each product is not necessarily performed.

TI assumes no liability for applications assistance or customer product design. Customers are responsible for their products and applications using TI components. To minimize the risks associated with customer products and applications, customers should provide adequate design and operating safeguards.

TI does not warrant or represent that any license, either express or implied, is granted under any TI patent right, copyright, mask work right, or other TI intellectual property right relating to any combination, machine, or process in which TI products or services are used. Information published by TI regarding third-party products or services does not constitute a license from TI to use such products or services or a warranty or endorsement thereof. Use of such information may require a license from a third party under the patents or other intellectual property of the third party, or a license from TI under the patents or other intellectual property of TI.

Reproduction of TI information in TI data books or data sheets is permissible only if reproduction is without alteration and is accompanied by all associated warranties, conditions, limitations, and notices. Reproduction of this information with alteration is an unfair and deceptive business practice. TI is not responsible or liable for such altered documentation. Information of third parties may be subject to additional restrictions.

Resale of TI products or services with statements different from or beyond the parameters stated by TI for that product or service voids all express and any implied warranties for the associated TI product or service and is an unfair and deceptive business practice. TI is not responsible or liable for any such statements.

TI products are not authorized for use in safety-critical applications (such as life support) where a failure of the TI product would reasonably be expected to cause severe personal injury or death, unless officers of the parties have executed an agreement specifically governing such use. Buyers represent that they have all necessary expertise in the safety and regulatory ramifications of their applications, and acknowledge and agree that they are solely responsible for all legal, regulatory and safety-related requirements concerning their products and any use of TI products in such safety-critical applications, notwithstanding any applications-related information or support that may be provided by TI. Further, Buyers must fully indemnify TI and its representatives against any damages arising out of the use of TI products in such safety-critical applications.

TI products are neither designed nor intended for use in military/aerospace applications or environments unless the TI products are specifically designated by TI as military-grade or "enhanced plastic." Only products designated by TI as military-grade meet military specifications. Buyers acknowledge and agree that any such use of TI products which TI has not designated as military-grade is solely at the Buyer's risk, and that they are solely responsible for compliance with all legal and regulatory requirements in connection with such use.

TI products are neither designed nor intended for use in automotive applications or environments unless the specific TI products are designated by TI as compliant with ISO/TS 16949 requirements. Buyers acknowledge and agree that, if they use any non-designated products in automotive applications, TI will not be responsible for any failure to meet such requirements.

Following are URLs where you can obtain information on other Texas Instruments products and application solutions:

Products

Audio	www.ti.com/audio
Amplifiers	amplifier.ti.com
Data Converters	dataconverter.ti.com
DLP® Products	www.dlp.com
DSP	dsp.ti.com
Clocks and Timers	www.ti.com/clocks
Interface	interface.ti.com
Logic	logic.ti.com
Power Mgmt	power.ti.com
Microcontrollers	microcontroller.ti.com
RFID	www.ti-rfid.com
RF/IF and ZigBee® Solutions	www.ti.com/lprf

Applications

Communications and Telecom	www.ti.com/communications
Computers and Peripherals	www.ti.com/computers
Consumer Electronics	www.ti.com/consumer-apps
Energy and Lighting	www.ti.com/energy
Industrial	www.ti.com/industrial
Medical	www.ti.com/medical
Security	www.ti.com/security
Space, Avionics and Defense	www.ti.com/space-avionics-defense
Transportation and Automotive	www.ti.com/automotive
Video and Imaging	www.ti.com/video
Wireless	www.ti.com/wireless-apps

TI E2E Community Home Page

e2e.ti.com

Mailing Address: Texas Instruments, Post Office Box 655303, Dallas, Texas 75265
Copyright © 2011, Texas Instruments Incorporated

www.BDTIC.com/TI