

1.8-GHz LOW-DISTORTION CURRENT-FEEDBACK AMPLIFIER

FEATURES

- **Unity Gain Bandwidth: 1.8 GHz**
- **High Slew Rate: 6700 V/μs (G = 2 V/V, R_L = 100 Ω, 5-V Step)**
- **IMD₃: –78 dBc at 20 MHz: (G = 10 V/V, R_L = 100 Ω, 2-V_{PP} Envelope)**
- **Noise Figure: 11 dB (G = 10 V/V, R_G = 28 Ω, R_F = 255 Ω)**
- **Input Referred Noise (f > 10 MHz)**
 - Voltage Noise: 1.65 nV/√Hz
 - Noninverting Current Noise: 13.4 pA/√Hz
 - Inverting Current Noise: 20 pA/√Hz
- **Output Drive: 100 mA**
- **Power-Supply Voltage Range: ±3.3 V to ±7.5 V**

SUPPORTS DEFENSE, AEROSPACE, AND MEDICAL APPLICATIONS

- **Controlled Baseline**
- **One Assembly/Test Site**
- **One Fabrication Site**
- **Available in Military (–55°C/125°C) Temperature Range⁽¹⁾**
- **Extended Product Life Cycle**
- **Extended Product-Change Notification**
- **Product Traceability**

APPLICATIONS

- **High-Resolution, High-Sampling-Rate Analog-to-Digital Converter Drivers**
- **High-Resolution, High-Sampling-Rate Digital-to-Analog Converter Output Buffers**
- **Test and Measurement**
- **ATE**

(1) Additional temperature ranges are available - contact factory

DESCRIPTION

The THS3201 is a wide-band, high-speed current-feedback amplifier, designed to operate over a wide supply range of ±3.3 V to ±7.5 V for today's high-performance applications.

The wide supply range, combined with low distortion and high slew rate, makes the THS3201 ideally suited for arbitrary waveform driver applications. The distortion performance also enables driving high-resolution and high-sampling rate ADCs.

High-voltage operation capabilities make the THS3201 especially suitable for many test, measurement, and ATE applications where lower-voltage devices do not offer enough voltage swing capability. Output rise and fall times are nearly independent of step size (to first-order approximation), making the THS3201 ideal for buffering small to large step pulses with excellent linearity in high dynamic systems.

The THS3201 is offered in 8-pin SOIC and 8-pin MSOP with PowerPAD™ packages.

RELATED DEVICES AND DESCRIPTIONS

| | |
|-----------|--|
| THS3202 | ±7.5-V 2-GHz Dual Low-Distortion CFB Amplifier |
| THS3001 | ±15-V 420-MHz Low-Distortion CFB Amplifier |
| THS3061/2 | ±15-V 300-MHz Low-Distortion CFB Amplifier |
| THS3122 | ±15-V Dual CFB Amplifier With 350-mA Drive |
| THS4271 | ±7.5-V 1.4-GHz Low-Distortion VFB Amplifier |



Please be aware that an important notice concerning availability, standard warranty, and use in critical applications of Texas Instruments semiconductor products and disclaimers thereto appears at the end of this data sheet.

PowerPAD is a trademark of Texas Instruments.

Low-Noise, Low-Distortion, Wideband Application Circuit

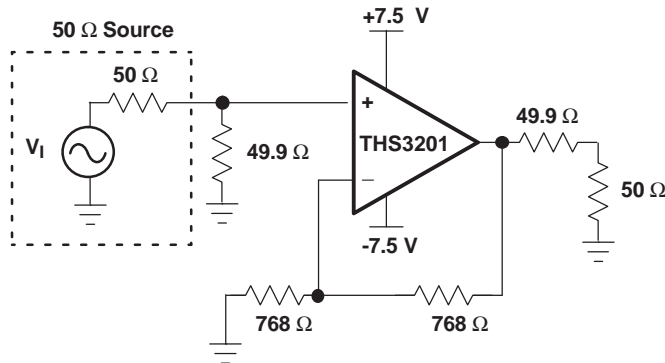

NOTE: Power supply decoupling capacitors not shown

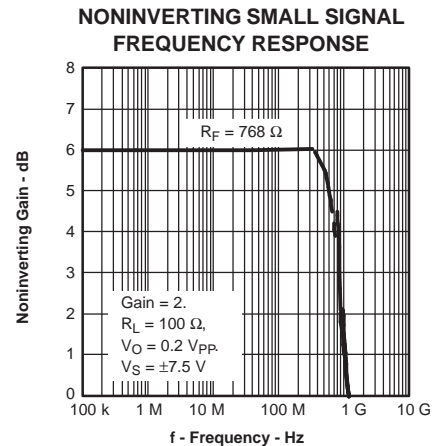

ABSOLUTE MAXIMUM RATINGS⁽¹⁾

over operating free-air temperature range (unless otherwise noted)

| | | |
|-------------|--|-------------------------------|
| V_S | Supply voltage | 16.5 V |
| V_I | Input voltage | $\pm V_S$ |
| I_O | Output current | 175 mA |
| V_{ID} | Differential input voltage | ± 3 V |
| | Continuous power dissipation | See Dissipation Ratings Table |
| T_J | Maximum junction temperature ⁽²⁾ | 150°C |
| T_J | Maximum junction temperature, continuous operation, long-term reliability ⁽³⁾ | 125°C |
| T_{stg} | Storage temperature range | -65°C to 150°C |
| | Lead temperature 1,6 mm (1/16 in) from case for 10 s | 300°C |
| ESD ratings | Human body model | 3000 V |
| | Charged device model | 1500 V |
| | Machines model | 100 V |

- (1) Stresses above these ratings may cause permanent damage. Exposure to absolute maximum conditions for extended periods may degrade device reliability. These are stress ratings only, and functional operation of the device at these or any other conditions beyond those specified is not implied.
- (2) The absolute maximum ratings under any condition are limited by the constraints of the silicon process. Stresses above these ratings may cause permanent damage. Exposure to absolute maximum conditions for extended periods may degrade device reliability. These are stress ratings only, and functional operation of the device at these or any other conditions beyond those specified is not implied.
- (3) Long-term high-temperature storage and/or extended use at maximum recommended operating conditions may result in a reduction of overall device life. See Figure 1 for additional information on thermal derating.

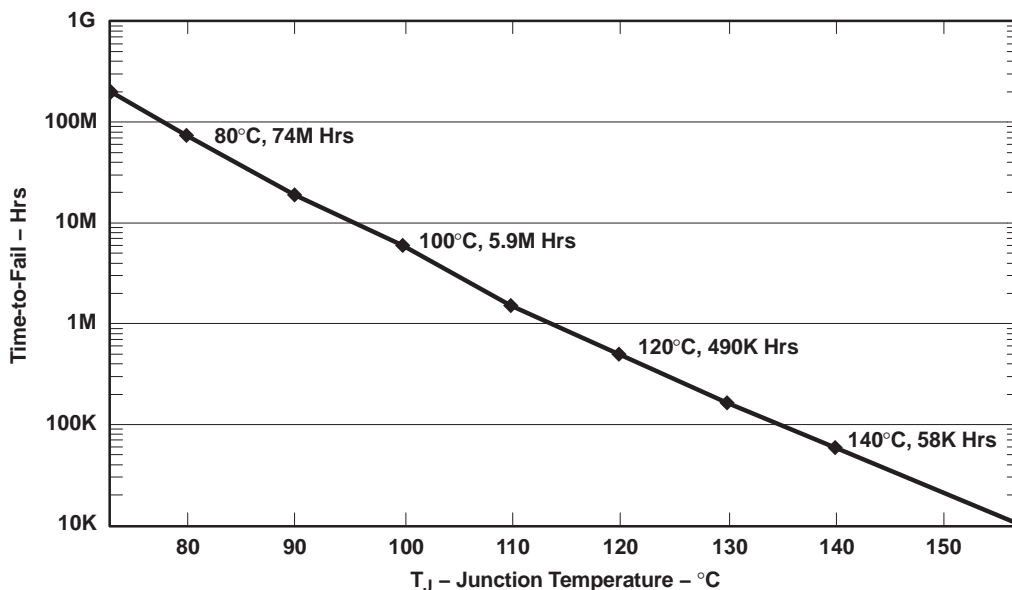

Figure 1. EME-G600 Estimated Wirebond Life

DISSIPATION RATINGS

| PACKAGE | θ_{JC} (°C/W) | θ_{JA} (1) (°C/W) |
|------------|----------------------|--------------------------|
| D (8) | 38.3 | 97.5 |
| DGN (8)(2) | 4.7 | 58.4 |

- (1) This data was taken using the JEDEC standard High-K test PCB.
- (2) The THS3201 may incorporate a thermal pad on the underside of the chip. This acts as a heat sink and must be connected to a thermally dissipative plane for proper power dissipation. Failure to do so may result in exceeding the maximum junction temperature; which could permanently damage the device. See Texas Instruments technical briefs SLMA002 and SLMA004 for more information about utilizing the PowerPAD thermally enhanced package.

RECOMMENDED OPERATING CONDITIONS

| | | MIN | MAX | UNIT |
|----------------|--------------------------------|------|------|------|
| Supply voltage | Dual supply | ±3.3 | ±7.5 | V |
| | Single supply | 6.6 | 15 | |
| T _A | Operating free air temperature | -55 | 125 | °C |

PACKAGE/ORDERING INFORMATION

| PART NUMBER | PACKAGE TYPE | PACKAGE MARKING | TRANSPORT MEDIA, QUANTITY |
|------------------|--------------|-----------------|---------------------------|
| THS3201MDEP(1) | SOIC-8 | — | Rails, 75 |
| THS3201MDREP(1) | | | Tape and reel, 2500 |
| THS3201MDGNEP(1) | MSOP-8-PP | BLM | Rails, 80 |
| THS3201MDGNREP | | | Tape and reel, 2500 |

(1) Product Preview

PIN ASSIGNMENTS

D OR DGN PACKAGE (TOP VIEW)

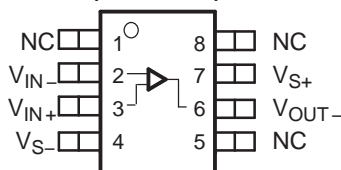

NC – No internal connection

- A. If a PowerPAD package is used, the thermal pad is electrically isolated from the active circuitry.

ELECTRICAL CHARACTERISTICS
 $V_S = \pm 7.5\text{ V}$; $R_f = 1\text{ k}\Omega$, $R_L = 100\ \Omega$, $G = +2$ (unless otherwise noted)

| PARAMETER | TEST CONDITIONS | TYP | OVER TEMPERATURE | | UNIT | MIN/ TYP/ MAX |
|---|---|-----------|------------------|-------------------|------------------------------|---------------------|
| | | 25°C | 25°C | –55°C to 125°C | | |
| AC Performance | | | | | | |
| Small-signal bandwidth, –3 dB ($V_O = 200\text{ mV}_{pp}$) | $G = +1$, $R_F = 1.2\text{ k}\Omega$ | 1.8 | | | GHz | Typ |
| | $G = +2$, $R_F = 768\ \Omega$ | 850 | | | MHz | |
| | $G = +5$, $R_F = 619\ \Omega$ | 565 | | | | |
| | $G = +10$, $R_F = 487\ \Omega$ | 520 | | | | |
| Bandwidth for 0.1-dB flatness | $G = +2$, $V_O = 200\text{ mV}_{pp}$, $R_F = 768\ \Omega$ | 380 | | | MHz | Typ |
| Large-signal bandwidth | $G = +2$, $V_O = 2\text{ V}_{pp}$, $R_F = 715\ \Omega$ | 880 | | | MHz | Typ |
| Slew rate (25% to 75% level) | $G = +2$, $V_O = 5\text{-V step}$, $R_F = 768\ \Omega$, Rise/fall | 5400/4000 | | | V/ μs | Typ |
| | $G = +2$, $V_O = 10\text{-V step}$, $R_F = 768\ \Omega$, Rise/fall | 9800/6700 | | | | |
| Rise and fall time | $G = +2$, $V_O = 4\text{-V step}$, $R_F = 768\ \Omega$, Rise/fall | 0.7/0.9 | | | ns | Typ |
| Settling time to 0.1% | $G = -2$, $V_O = 2\text{-V step}$ | 20 | | | ns | Typ |
| Settling time to 0.01% | | 60 | | | | |
| Harmonic distortion | | | | | | |
| Second-order harmonic | $G = +5$, $f = 10\text{ MHz}$, $V_O = 2\text{ V}_{pp}$, $R_L = 100\ \Omega$ | –64 | | | dBc | Typ |
| Third-order harmonic | | –73 | | | | |
| Third-order intermodulation distortion (IMD ₃) | $G = +10$, $f_c = 20\text{ MHz}$, $\Delta f = 1\text{ MHz}$, $V_{O(\text{envelope})} = 2\text{ V}_{pp}$ | –78 | | | dBc | Typ |
| Noise figure | $G = +10$, $f_c = 100\text{ MHz}$, $R_F = 255\ \Omega$, $R_G = 28$ | 11 | | | dB | Typ |
| Input voltage noise | $f > 10\text{ MHz}$ | 1.65 | | | nV/ $\sqrt{\text{Hz}}$ | Typ |
| Input current noise (noninverting) | $f > 10\text{ MHz}$ | 13.4 | | | pA/ $\sqrt{\text{Hz}}$ | Typ |
| Input current noise (inverting) | | 20 | | | | |
| Differential gain | $G = +2$, $R_L = 150\ \Omega$, $R_F = 768\ \Omega$ | NTSC | 0.008 | | % | Typ |
| | | PAL | 0.004 | | | |
| Differential phase | $G = +2$, $R_L = 150\ \Omega$, $R_F = 768\ \Omega$ | NTSC | 0.007 | | ° | Typ |
| | | PAL | 0.011 | | | |
| DC Performance | | | | | | |
| Open-loop transimpedance gain | $V_O = \pm 4\text{ V}$, $R_L = 1\text{ k}\Omega$ | 300 | 200 | 100 | k Ω | Min |
| Input offset voltage | $V_{CM} = 0\text{ V}$, $R_L = 1\text{ k}\Omega$ | ± 0.7 | ± 4 | ± 6 | mV | Max |
| Average offset voltage drift | $V_{CM} = 0\text{ V}$, $R_L = 1\text{ k}\Omega$ | | | ± 13 | $\mu\text{V}/^\circ\text{C}$ | Typ |
| Input bias current (inverting) | $V_{CM} = 0\text{ V}$, $R_L = 1\text{ k}\Omega$ | ± 13 | ± 65 | ± 90 | μA | Max |
| Average bias current drift (–) | $V_{CM} = 0\text{ V}$, $R_L = 1\text{ k}\Omega$ | | | ± 400 | nA/ $^\circ\text{C}$ | Typ |
| Input bias current (noninverting) | $V_{CM} = 0\text{ V}$, $R_L = 1\text{ k}\Omega$ | ± 14 | ± 40 | ± 60 | μA | Max |
| Average bias current drift (+) | $V_{CM} = 0\text{ V}$, $R_L = 1\text{ k}\Omega$ | | | ± 400 | nA/ $^\circ\text{C}$ | Typ |

ELECTRICAL CHARACTERISTICS (continued)
 $V_S = \pm 7.5\text{ V}$; $R_f = 1\text{ k}\Omega$, $R_L = 100\ \Omega$, $G = +2$ (unless otherwise noted)

| PARAMETER | TEST CONDITIONS | TYP | OVER TEMPERATURE | | UNIT | MIN/ TYP/ MAX |
|-------------------------------------|---|-----------|------------------|-------------------|------------|---------------------|
| | | 25°C | 25°C | –55°C to 125°C | | |
| Input | | | | | | |
| Common-mode input range | $R_L = 1\text{ k}\Omega$ | ± 5.1 | ± 5 | ± 5 | V | Min |
| Common-mode rejection ratio | $V_{CM} = \pm 3.75\text{ V}$ | 71 | 58 | 53 | dB | Min |
| Inverting input impedance, Z_{in} | Open loop | 16 | | | Ω | Typ |
| Input resistance | Noninverting | 780 | | | k Ω | Typ |
| | Inverting | 11 | | | Ω | |
| Input capacitance | Noninverting | 1 | | | pF | Typ |
| Output | | | | | | |
| Voltage output swing | $R_L = 1\text{ k}\Omega$ | ± 6 | ± 5.9 | ± 5.7 | V | Min |
| | $R_L = 100\ \Omega$ | ± 5.8 | ± 5.7 | ± 5.35 | | |
| Current output, sourcing | $R_L = 20\ \Omega$ | 115 | 105 | 100 | mA | Min |
| Current output, sinking | $R_L = 20\ \Omega$ | 100 | 85 | 80 | mA | Min |
| Closed-loop output impedance | $G = +1$, $f = 1\text{ MHz}$ | 0.01 | | | Ω | Typ |
| Power Supply | | | | | | |
| Minimum operating voltage | Absolute minimum | | ± 3.3 | ± 3.3 | V | Min |
| Maximum operating voltage | Absolute maximum | | ± 7.5 | ± 7.5 | V | Max |
| Maximum quiescent current | Output open | 14 | 18 | 22 | mA | Max |
| Power-supply rejection (+PSRR) | $V_{S+} = 7\text{ V to } 8\text{ V}$, $R_L = 1\text{ k}\Omega$ | 69 | 60 | 56 | dB | Min |
| Power-supply rejection (–PSRR) | $V_{S-} = -7\text{ V to } -8\text{ V}$, $R_L = 1\text{ k}\Omega$ | 65 | 58 | 55 | dB | Min |

ELECTRICAL CHARACTERISTICS
 $V_S = \pm 5\text{ V}$; $R_f = 1\text{ k}\Omega$, $R_L = 100\ \Omega$, $G = +2$ (unless otherwise noted)

| PARAMETER | TEST CONDITIONS | TYP | OVER TEMPERATURE | | UNIT | MIN/ TYP/ MAX | |
|---|---|---------------------|------------------|-------------------|------------------|------------------------------|-----|
| | | 25°C | 25°C | –55°C to 125°C | | | |
| AC Performance | | | | | | | |
| Small-signal bandwidth, –3 dB ($V_O = 200\text{ mV}_{pp}$) | $G = +1$, $R_F = 1.2\text{ k}\Omega$ | 1.3 | | | GHz | Typ | |
| | $G = +2$, $R_F = 715\ \Omega$ | 725 | | | MHz | | |
| | $G = +5$, $R_F = 576\ \Omega$ | 540 | | | | | |
| | $G = +10$, $R_F = 464\ \Omega$ | 480 | | | | | |
| Bandwidth for 0.1-dB flatness | $G = +2$, $V_O = 200\text{ mV}_{pp}$, $R_F = 715\ \Omega$ | 170 | | | MHz | Typ | |
| Large-signal bandwidth | $G = +2$, $V_O = 2\text{ V}_{pp}$, $R_F = 715\ \Omega$ | 900 | | | MHz | Typ | |
| Slew rate (25% to 75% level) | $G = +2$, $V_O = 5\text{-V step}$, $R_F = 715\ \Omega$, Rise/Fall | 5200/4000 | | | V/ μs | Typ | |
| Rise and fall time | $G = +2$, $V_O = 4\text{-V step}$, $R_F = 715\ \Omega$, Rise/Fall | 0.7/0.9 | | | ns | Typ | |
| Settling time to 0.1% | $G = -2$, $V_O = 2\text{-V step}$ | 20 | | | ns | Typ | |
| Settling time to 0.01% | | 60 | | | | | |
| Harmonic distortion | | | | | | | |
| Second-order harmonic | $G = +5$, $f = 10\text{ MHz}$, $V_O = 2\text{ V}_{pp}$ | $R_L = 100\ \Omega$ | –69 | | | dBc | Typ |
| Third-order harmonic | $G = +5$, $f = 10\text{ MHz}$, $V_O = 2\text{ V}_{pp}$ | $R_L = 100\ \Omega$ | –75 | | | dBc | Typ |
| Third-order intermodulation distortion (IMD ₃) | $G = +10$, $f_c = 20\text{ MHz}$, $\Delta f = 1\text{ MHz}$, $V_{O(\text{envelope})} = 2\text{ V}_{pp}$ | | –81 | | | dBc | Typ |
| Noise figure | $G = +10$, $f_c = 100\text{ MHz}$, $R_F = 255\ \Omega$, $R_G = 28$ | | 11 | | | dB | Typ |
| Input voltage noise | $f > 10\text{ MHz}$ | | 1.65 | | | nV/ $\sqrt{\text{Hz}}$ | Typ |
| Input current noise (noninverting) | $f > 10\text{ MHz}$ | | 13.4 | | | pA/ $\sqrt{\text{Hz}}$ | Typ |
| Input current noise (inverting) | | | 20 | | | pA/ $\sqrt{\text{Hz}}$ | Typ |
| Differential gain | $G = +2$, $R_L = 150\ \Omega$, $R_F = 768\ \Omega$ | NTSC | 0.006 | | | % | Typ |
| | | PAL | 0.004 | | | | |
| Differential phase | $G = +2$, $R_L = 150\ \Omega$, $R_F = 768\ \Omega$ | NTSC | 0.03 | | | ° | Typ |
| | | PAL | 0.04 | | | | |
| DC Performance | | | | | | | |
| Open-loop transimpedance gain | $V_O = \pm 2\text{ V}$, $R_L = 1\text{ k}\Omega$ | | 300 | 200 | 100 | k Ω | Min |
| Input offset voltage | $V_{CM} = 0\text{ V}$, $R_L = 1\text{ k}\Omega$ | | ± 0.7 | ± 3 | ± 5.5 | mV | Max |
| Average offset voltage drift | $V_{CM} = 0\text{ V}$, $R_L = 1\text{ k}\Omega$ | | | | ± 13 | $\mu\text{V}/^\circ\text{C}$ | Typ |
| Input bias current (inverting) | $V_{CM} = 0\text{ V}$, $R_L = 1\text{ k}\Omega$ | | ± 13 | ± 65 | ± 90 | μA | Max |
| Average bias current drift (–) | $V_{CM} = 0\text{ V}$, $R_L = 1\text{ k}\Omega$ | | | | ± 400 | nA/ $^\circ\text{C}$ | Typ |
| Input bias current (noninverting) | $V_{CM} = 0\text{ V}$, $R_L = 1\text{ k}\Omega$ | | ± 14 | ± 40 | ± 60 | μA | Max |
| Average bias current drift (+) | $V_{CM} = 0\text{ V}$, $R_L = 1\text{ k}\Omega$ | | | | ± 400 | nA/ $^\circ\text{C}$ | Typ |

ELECTRICAL CHARACTERISTICS (continued)
 $V_S = \pm 5\text{ V}$; $R_f = 1\text{ k}\Omega$, $R_L = 100\ \Omega$, $G = +2$ (unless otherwise noted)

| PARAMETER | TEST CONDITIONS | TYP | OVER TEMPERATURE | | UNIT | MIN/ TYP/ MAX |
|-------------------------------------|---|------------|------------------|-------------------|------------|---------------------|
| | | 25°C | 25°C | –55°C to 125°C | | |
| Input | | | | | | |
| Common-mode input range | $R_L = 1\text{ k}\Omega$ | ± 2.6 | ± 2.5 | ± 2.5 | V | Min |
| Common-mode rejection ratio | $V_{CM} = \pm 2.5\text{ V}$ | 71 | 56 | 50 | dB | Min |
| Inverting input impedance, Z_{in} | Open loop, $R_L = 1\text{ k}\Omega$ | 17.5 | | | Ω | Typ |
| Input resistance | Noninverting | 780 | | | k Ω | Typ |
| | Inverting | 11 | | | Ω | |
| Input capacitance | Noninverting | 1 | | | pF | Typ |
| Output | | | | | | |
| Voltage output swing | $R_L = 1\text{ k}\Omega$ | ± 3.65 | ± 3.5 | ± 3.4 | V | Min |
| | $R_L = 100\ \Omega$ | ± 3.45 | ± 3.33 | ± 3.2 | | |
| Current output, sourcing | $R_L = 20\ \Omega$ | 115 | 105 | 90 | mA | Min |
| Current output, sinking | $R_L = 20\ \Omega$ | 100 | 80 | 75 | mA | Min |
| Closed-loop output impedance | $G = +1$, $f = 1\text{ MHz}$ | 0.01 | | | Ω | Typ |
| Power Supply | | | | | | |
| Minimum operating voltage | Absolute minimum | | ± 3.3 | ± 3.3 | V | Min |
| Maximum operating voltage | Absolute maximum | | ± 7.5 | ± 7.5 | V | Max |
| Maximum quiescent current | | 14 | 16.8 | 20.5 | mA | Max |
| Power-supply rejection (+PSRR) | $V_{S+} = 4.5\text{ V to } 5.5\text{ V}$, $R_L = 1\text{ k}\Omega$ | 69 | 60 | 56 | dB | Min |
| Power-supply rejection (–PSRR) | $V_{S-} = -4.5\text{ V to } -5.5\text{ V}$, $R_L = 1\text{ k}\Omega$ | 65 | 58 | 55 | dB | Min |

TYPICAL CHARACTERISTICS

Table of Graphs ($V_S = \pm 7.5\text{ V}$)

| | | FIGURE NO. |
|--|---------------------|------------|
| Noninverting small-signal frequency response | | 2, 3 |
| Inverting small-signal frequency response | | 4 |
| Inverting large-signal frequency response | | 5, 6 |
| 0.1-dB gain flatness frequency response | | 7 |
| Capacitive load frequency response | | 8 |
| Recommended switching resistance | vs Capacitive load | 9 |
| 2nd harmonic distortion | vs Frequency | 10 |
| 3rd harmonic distortion | vs Frequency | 11 |
| 2nd-order harmonic distortion, $G = 2$ | vs Output voltage | 12 |
| 3rd-order harmonic distortion, $G = 2$ | vs Output voltage | 13 |
| 2nd-order harmonic distortion, $G = 5$ | vs Output voltage | 14 |
| 3rd-order harmonic distortion, $G = 5$ | vs Output voltage | 15 |
| 2nd-order harmonic distortion, $G = 10$ | vs Output voltage | 16 |
| 3rd-order harmonic distortion, $G = 10$ | vs Output voltage | 17 |
| 3rd-order intermodulation distortion (IMD_3) | vs Frequency | 18 |
| S-Parameter | vs Frequency | 19, 20 |
| Input voltage and current noise | vs Frequency | 21 |
| Noise figure | vs Frequency | 22 |
| Transimpedance | vs Frequency | 23 |
| Input offset voltage | vs Case temperature | 24 |
| Input bias and offset current | vs Case temperature | 25 |
| Slew rate | vs Output voltage | 26 |
| Settling time | | 27, 28 |
| Quiescent current | vs Supply voltage | 29 |
| Output voltage | vs Load resistance | 30 |
| Rejection ratio | vs Frequency | 31 |
| Noninverting small-signal transient response | | 32 |
| Inverting large-signal transient response | | 33 |
| Overdrive recovery time | | 34 |
| Differential gain | vs Number of loads | 35 |
| Differential phase | vs Number of loads | 36 |
| Closed-loop output impedance | vs Frequency | 37 |

Table of Graphs ($V_S = \pm 5\text{ V}$)

| | | Figure No. |
|--|-------------------|-------------------|
| Noninverting small-signal frequency response | | 38 |
| Inverting small-signal frequency response | | 39 |
| 0.1-dB gain flatness frequency response | | 40 |
| 2nd-order harmonic distortion | vs Frequency | 41 |
| 3rd-order harmonic distortion | vs Frequency | 42 |
| 2nd-order harmonic distortion, G = 2 | vs Output voltage | 43 |
| 3rd-order harmonic distortion, G = 2 | vs Output voltage | 44 |
| 2nd-order harmonic distortion, G = 5 | vs Output voltage | 45 |
| 3rd-order harmonic distortion, G = 5 | vs Output voltage | 46 |
| 2nd-order harmonic distortion, G = 10 | vs Output voltage | 47 |
| 3rd-order harmonic distortion, G = 10 | vs Output voltage | 48 |
| 3rd-order intermodulation distortion (IMD ₃) | vs Frequency | 49 |
| S-Parameter | vs Frequency | 50, 51 |
| Slew rate | vs Output voltage | 52 |
| Noninverting small-signal transient response | | 53 |
| Inverting large-signal transient response | | 54 |
| Overdrive recovery time | | 55 |

$V_S = \pm 7.5\text{ V}$ Graphs

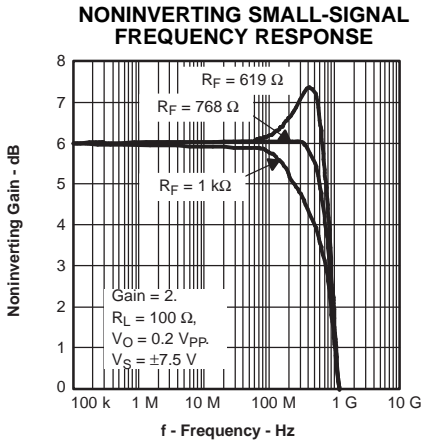

Figure 2.

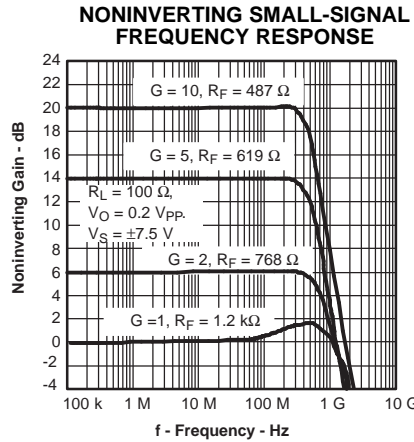

Figure 3.

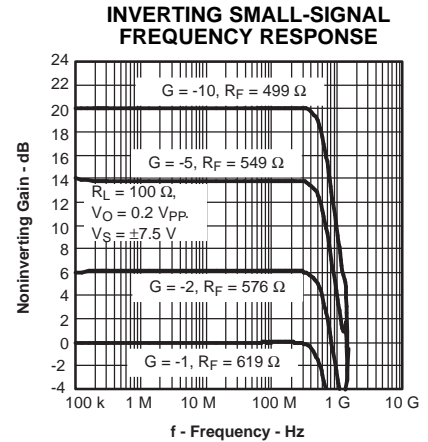

Figure 4.

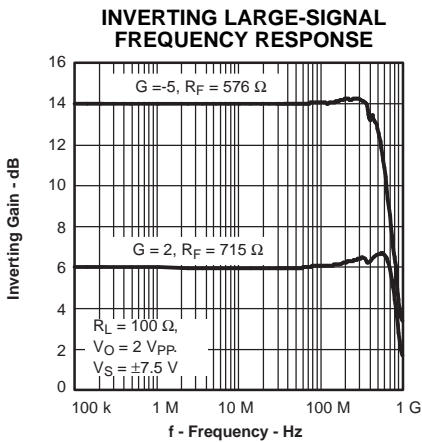

Figure 5.

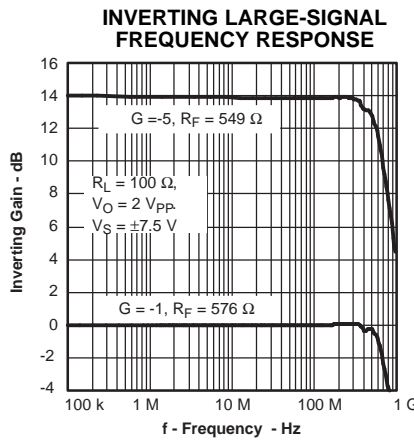

Figure 6.

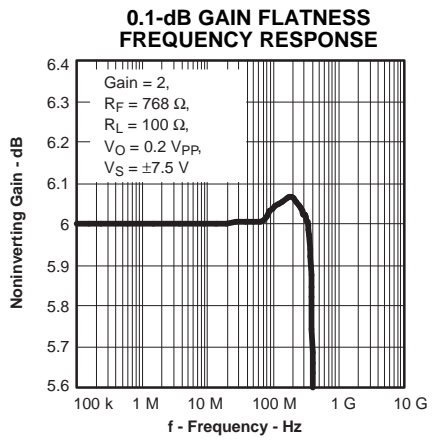

Figure 7.

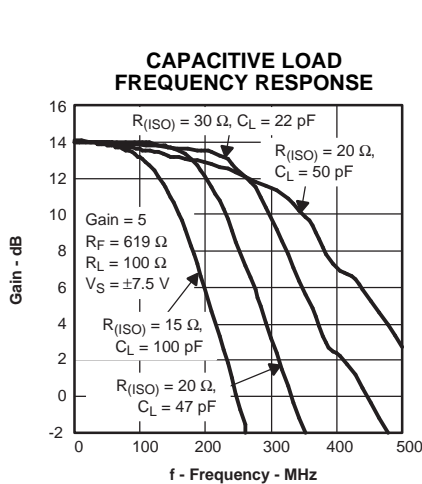

Figure 8.

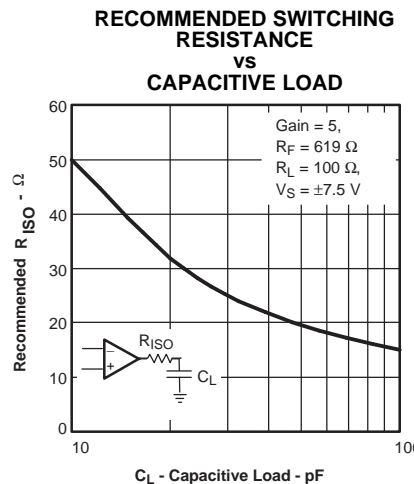

Figure 9.

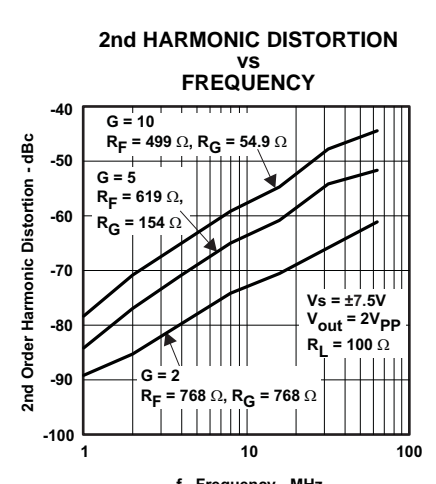

Figure 10.

$V_S = \pm 7.5$ V Graphs (continued)

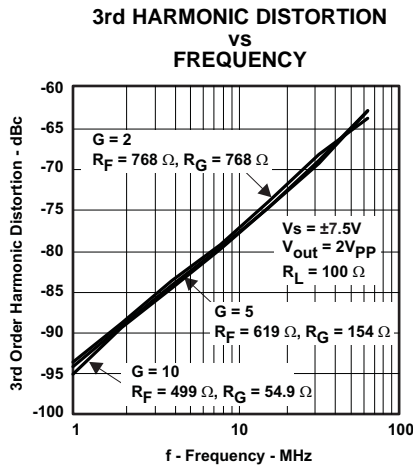

Figure 11.

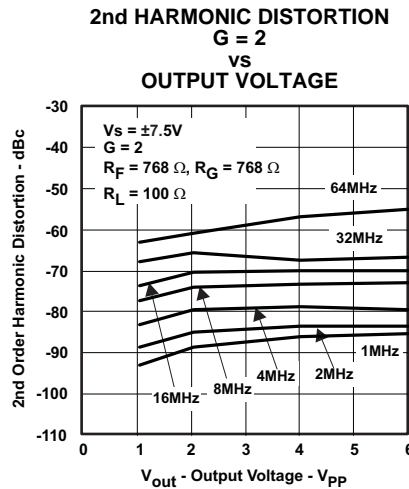

Figure 12.

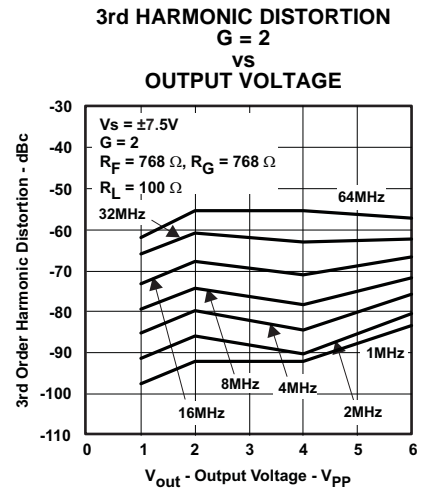

Figure 13.

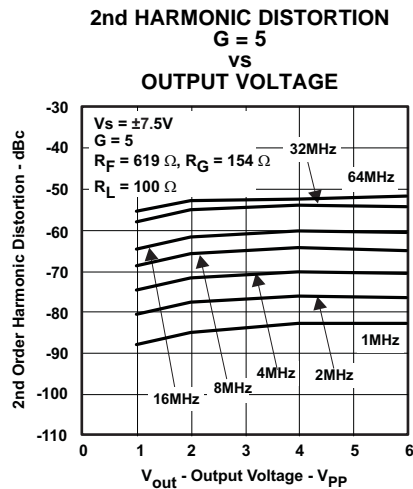

Figure 14.

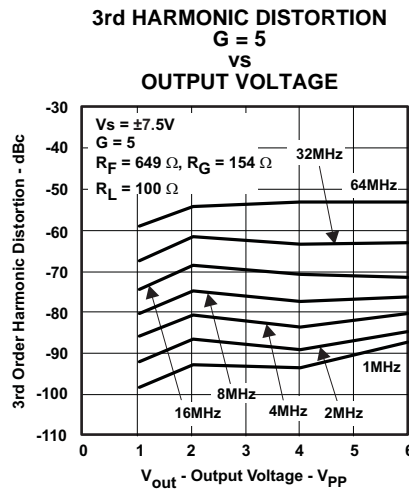

Figure 15.

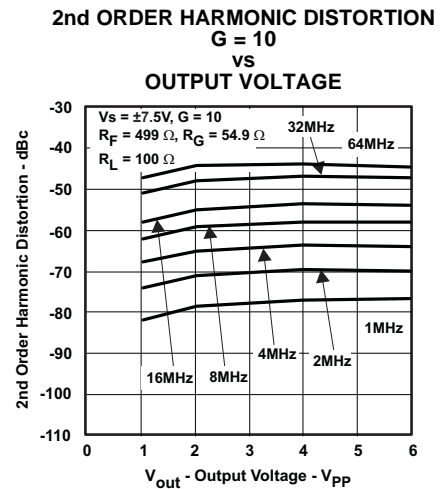

Figure 16.

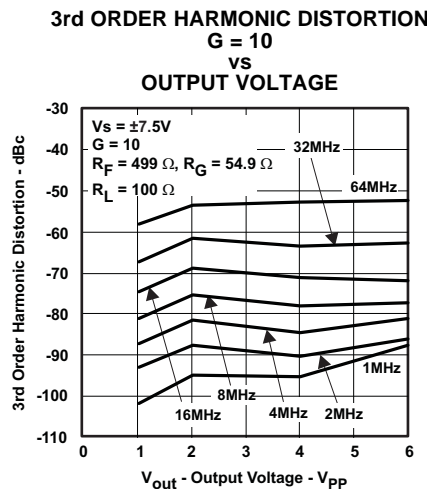

Figure 17.

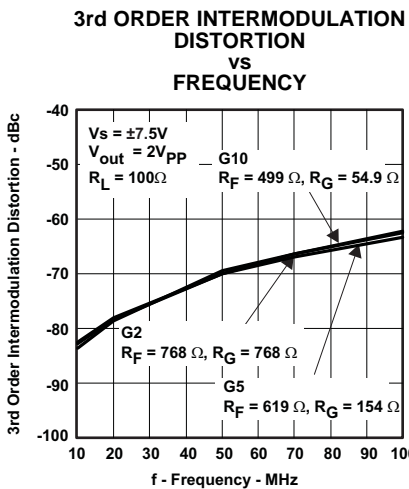

Figure 18.

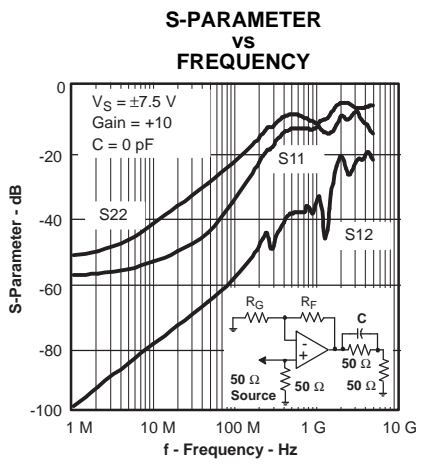

Figure 19.

$V_S = \pm 7.5$ V Graphs (continued)

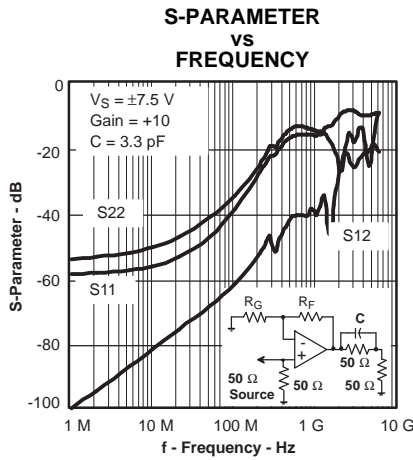

Figure 20.

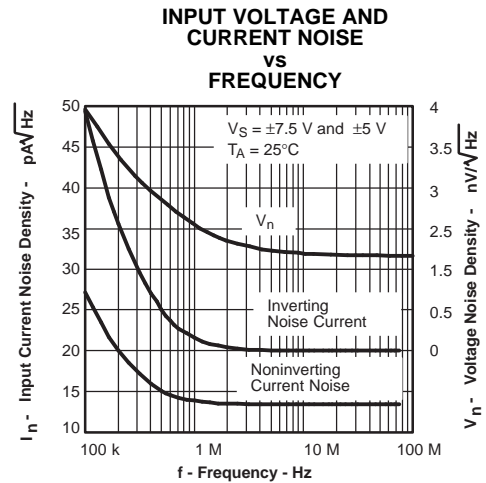

Figure 21.

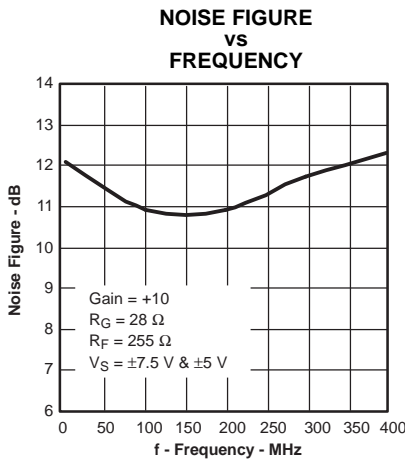

Figure 22.

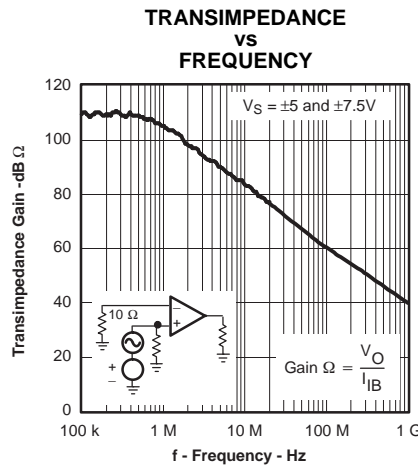

Figure 23.

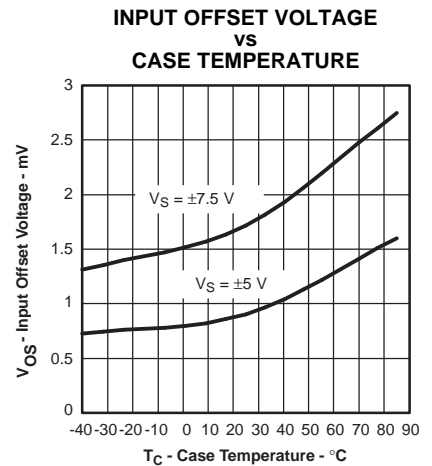

Figure 24.

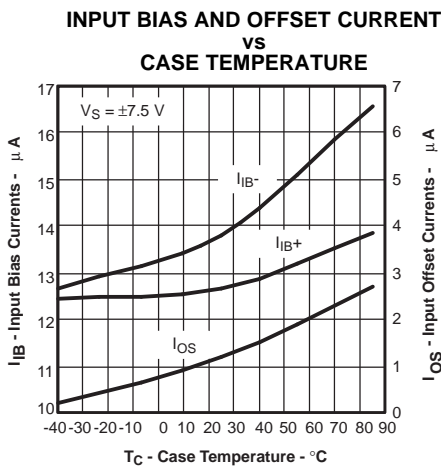

Figure 25.

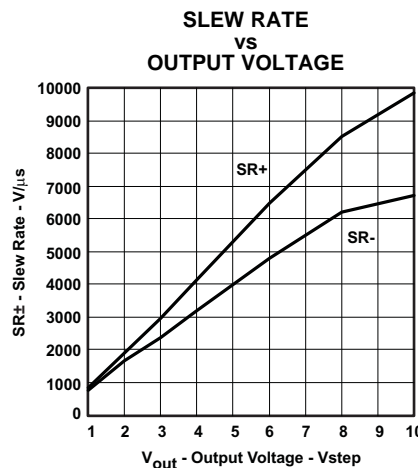

Figure 26.

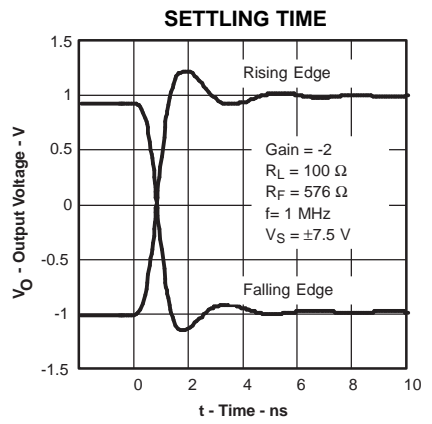

Figure 27.

$V_S = \pm 7.5$ V Graphs (continued)

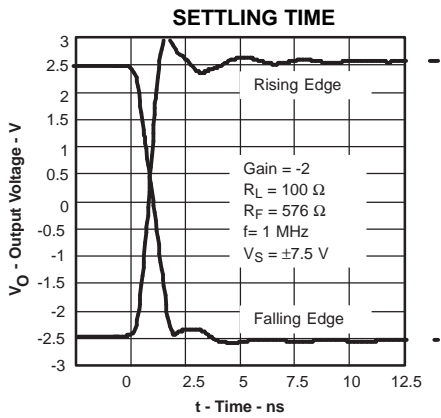

Figure 28.

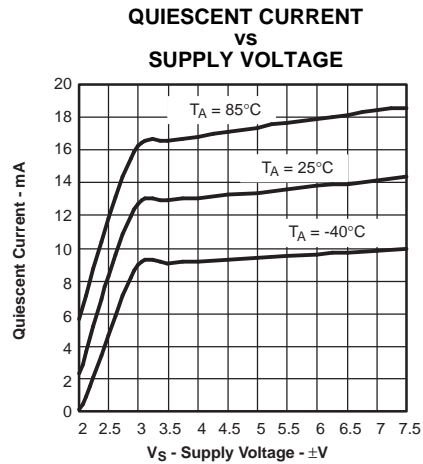

Figure 29.

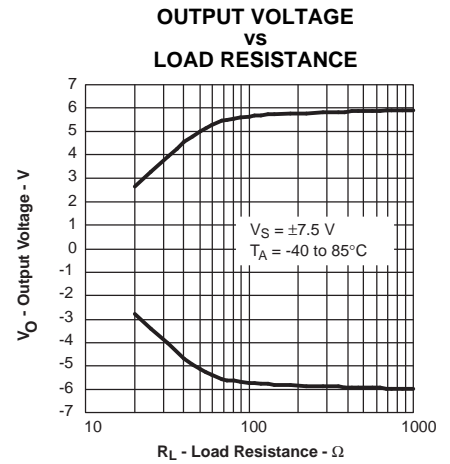

Figure 30.

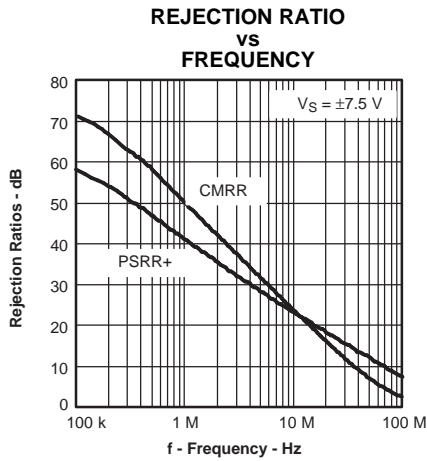

Figure 31.

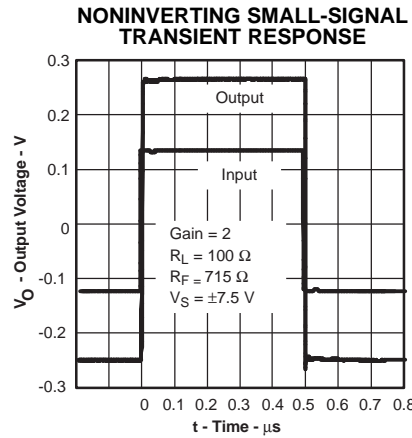

Figure 32.

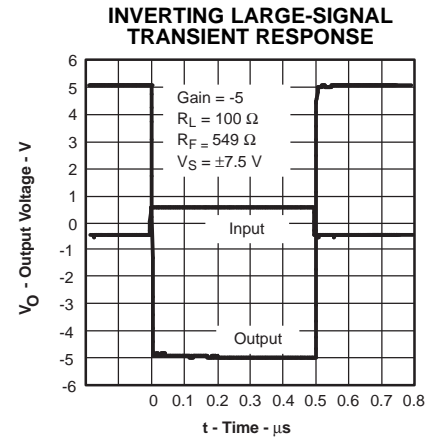

Figure 33.

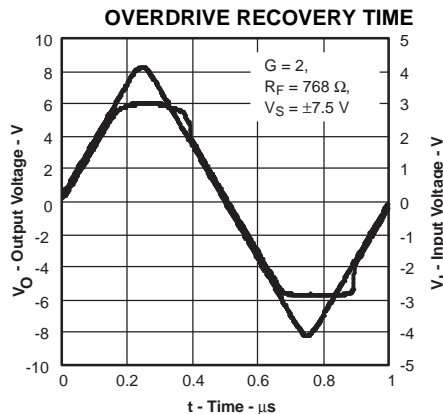

Figure 34.

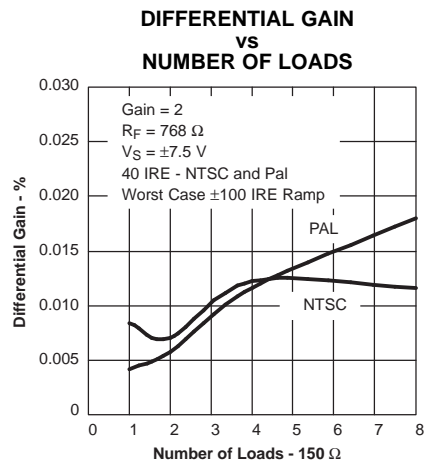

Figure 35.

$V_S = \pm 7.5$ V Graphs (continued)

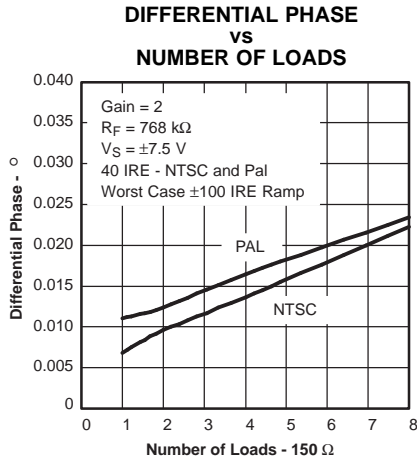

Figure 36.

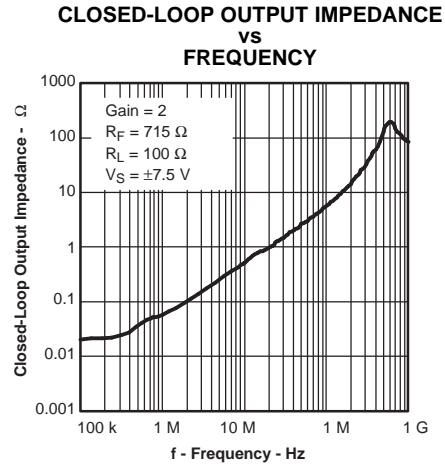

Figure 37.

$V_S = \pm 5$ V Graphs

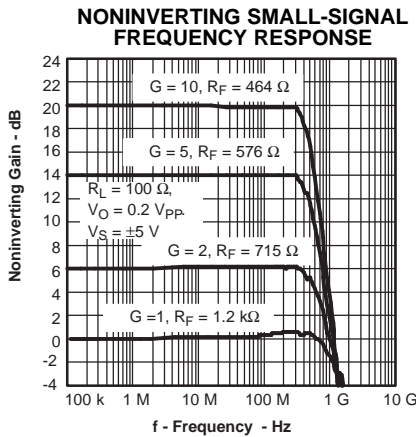

Figure 38.

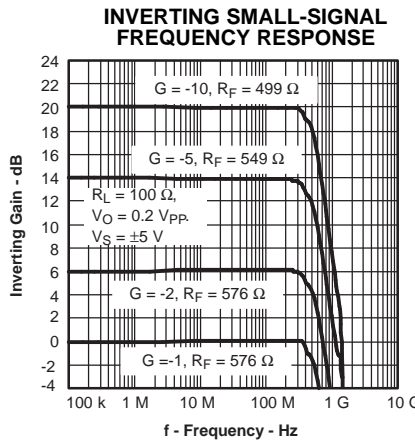

Figure 39.

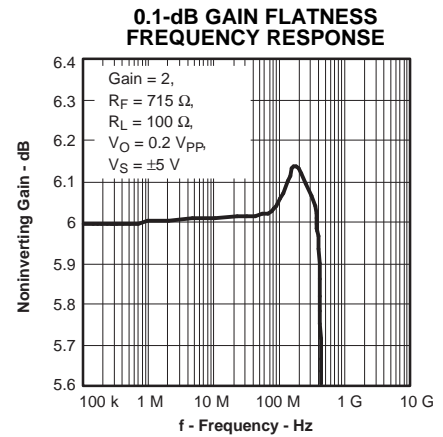

Figure 40.

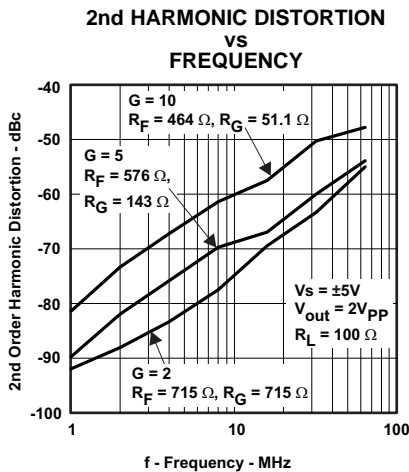

Figure 41.

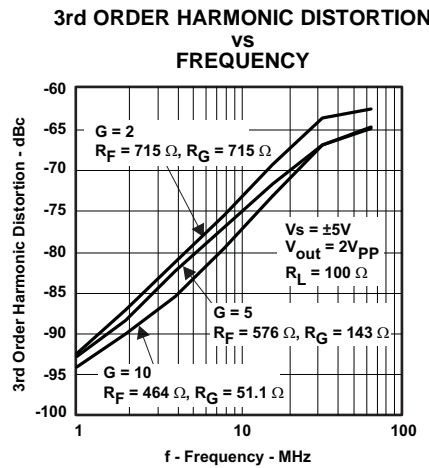

Figure 42.

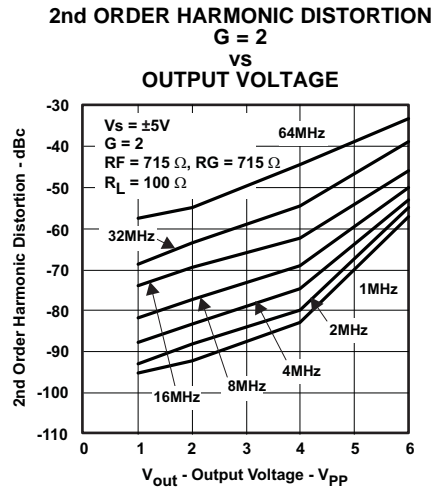

Figure 43.

$V_s = \pm 5$ V Graphs (continued)

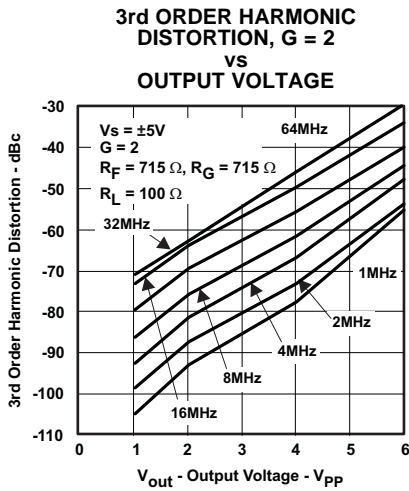

Figure 44.

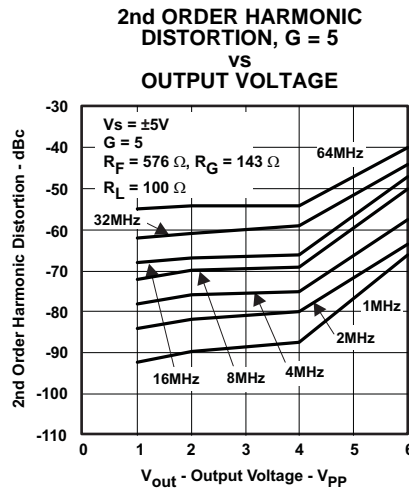

Figure 45.

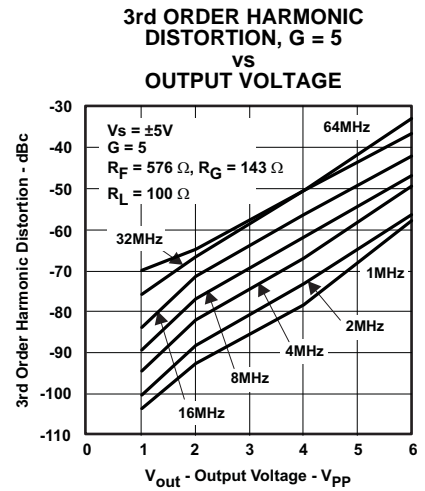

Figure 46.

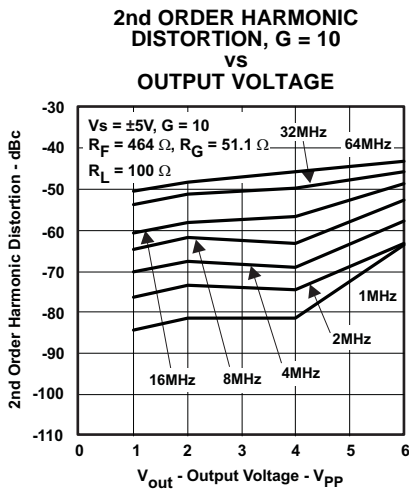

Figure 47.

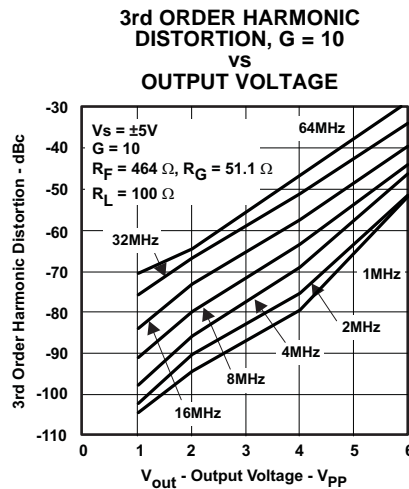

Figure 48.

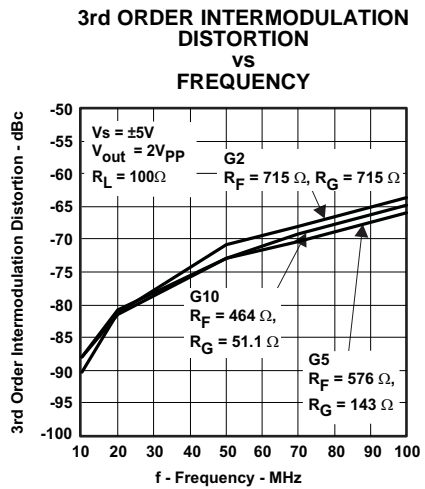

Figure 49.

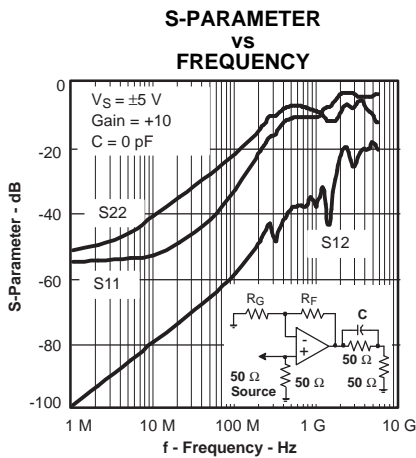

Figure 50.

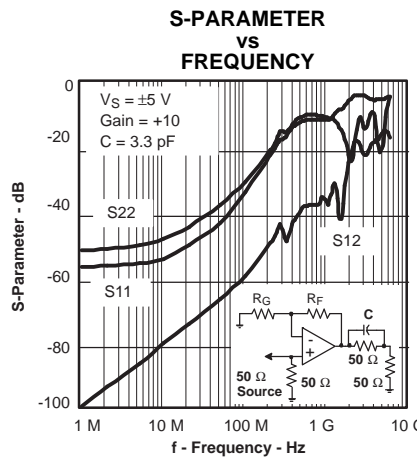

Figure 51.

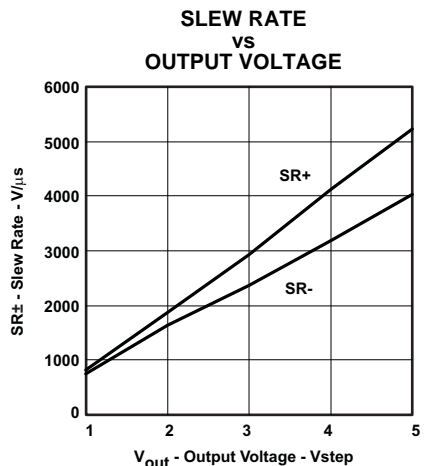

Figure 52.

$V_S = \pm 5\text{ V}$ Graphs (continued)

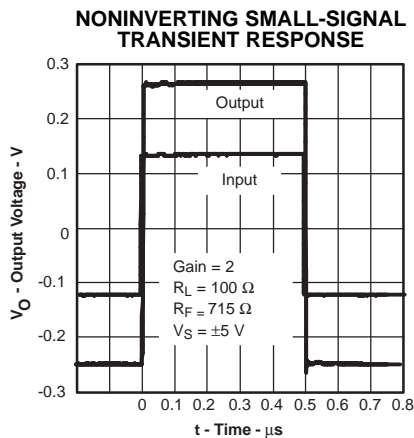

Figure 53.

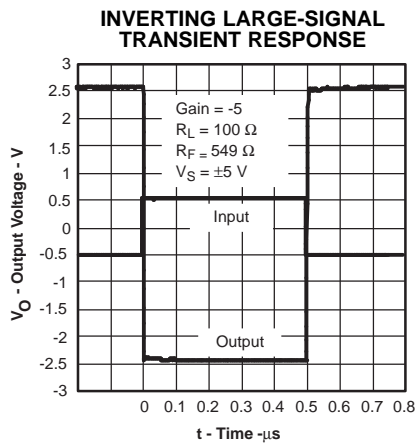

Figure 54.

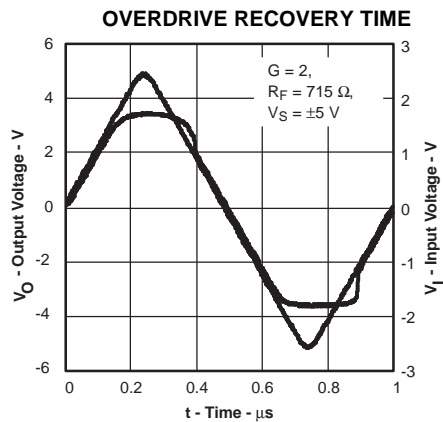

Figure 55.

APPLICATION INFORMATION

Wideband Noninverting Operation

The THS3201 is a unity gain stable 1.8-GHz current-feedback operational amplifier, designed to operate from a ± 3.3 -V to ± 7.5 -V power supply.

Figure 56 shows the THS3201 in a noninverting gain of 2-V/V configuration typically used to generate the performance curves. Most of the curves are characterized using signal sources with 50- Ω source impedance, and with measurement equipment presenting a 50- Ω load impedance. The 49.9- Ω shunt resistor at the V_I terminal in Figure 56 matches the source impedance of the test generator.

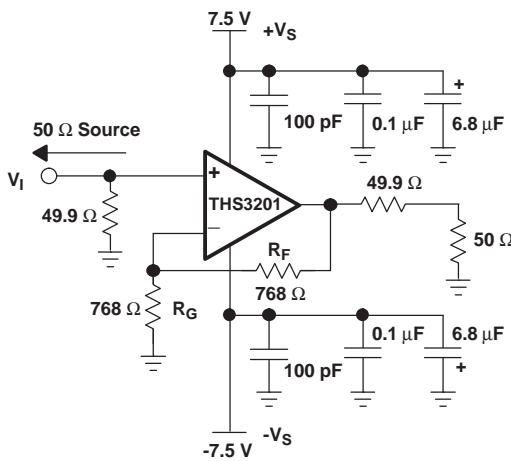

Figure 56. Wideband Noninverting Gain Configuration

Unlike voltage-feedback amplifiers, current-feedback amplifiers are highly dependent on the feedback resistor R_F for maximum performance and stability. Table 1 shows the optimal gain setting resistors R_F and R_G at different gains to give maximum bandwidth with minimal peaking in the frequency response. Higher bandwidths can be achieved, at the expense of added peaking in the frequency response, by using even lower values for R_F . Conversely, increasing R_F decreases the bandwidth, but stability is improved.

Table 1. Recommended Resistor Values for Optimum Frequency Response

| THS3201 R_F for AC When $R_{load} = 100 \Omega$ | | | |
|---|-----------------------|--------------------|--------------------|
| Gain (V/V) | Supply Voltage (V) | R_G (Ω) | R_F (Ω) |
| 1 | ± 7.5 | — | 1.2 k |
| | ± 5 | — | 1.2 k |
| 2 | ± 7.5 | 768 | 768 |
| | ± 5 | 715 | 715 |
| 5 | ± 7.5 | 154.9 | 619 |
| | ± 5 | 143 | 576 |
| 10 | ± 7.5 | 54.9 | 487 |
| | ± 5 | 51.1 | 464 |
| -1 | ± 7.5 | 619 | 619 |
| | ± 5 | 576 | 576 |
| -2 | ± 7.5 and ± 5 | 287 | 576 |
| -5 | ± 7.5 and ± 5 | 110 | 549 |
| -10 | ± 7.5 and ± 5 | 49.9 | 499 |

Wideband Inverting Gain Operation

Figure 57 shows the THS3201 is a typical inverting gain configuration, where the input and output impedances and signal gain from Figure 56 are retained in an inverting circuit configuration.

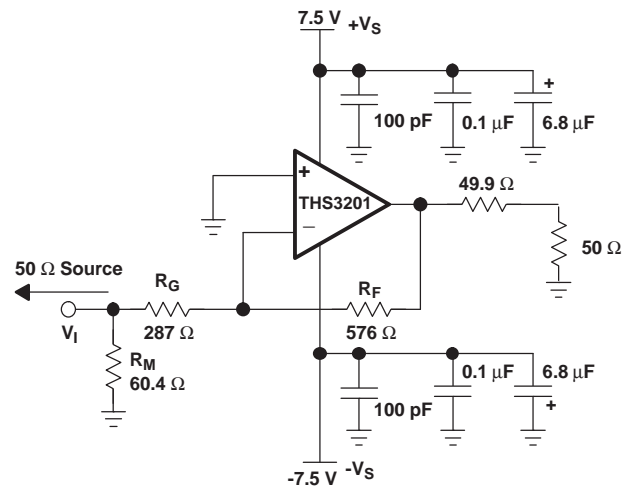

Figure 57. Wideband Inverting Gain Configuration

Single Supply Operation

The THS3201 has the capability to operate from a single-supply voltage ranging from 6.6 V to 15 V. When operating from a single power supply, care must be taken to ensure the input signal and amplifier is biased appropriately to allow for the maximum output voltage swing. The circuits shown in [Figure 58](#) demonstrate methods to configure an amplifier in a manner conducive for single-supply operation

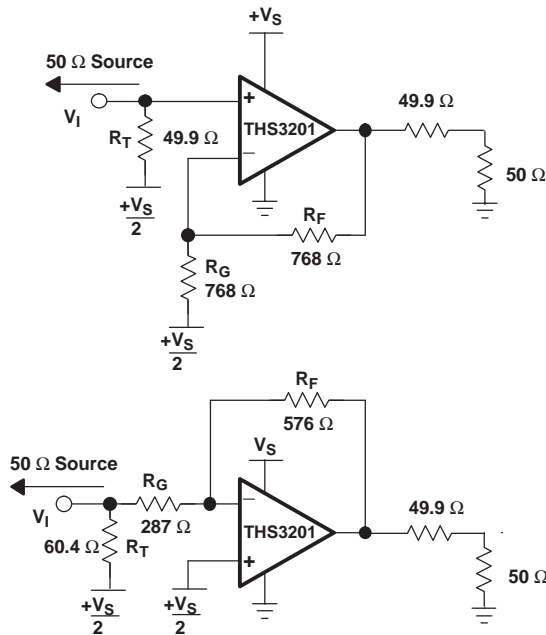

Figure 58. DC-Coupled Single-Supply Operation

Video HDTV Drivers

The exceptional bandwidth and slew rate of the THS3201 matches the demands for professional video and HDTV. Most commercial HDTV standards require a video passband of 30 MHz. To ensure high signal quality with minimal degradation of performance, a 0.1-dB gain flatness should be at least 7x the passband frequency to minimize group delay variations requiring 210-MHz 0.1-dB frequency flatness from the amplifier. High slew rates ensure there is minimal distortion of the video signal. Component video and RGB video signals require fast transition times and fast settling times to keep high signal quality. The THS8135, for example, is a 240-MSPS video DAC and has a transition time approaching 4 ns. The THS3201 is a perfect candidate for interfacing the output of such high-performance video components.

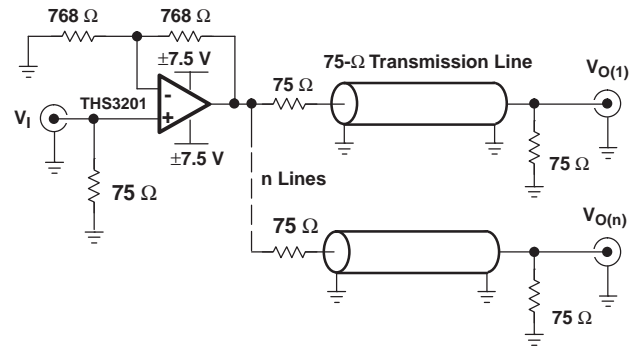

Figure 59. Video Distribution Amplifier Application

ADC Driver Application

The THS3201 can be used as a high-performance ADC driver in applications such as radio receiver IF stages and test and measurement devices. All high-performance ADCs have differential inputs. The THS3201 can be used in conjunction with a transformer as a drive amplifier in these applications. [Figure 60](#) and [Figure 61](#) show two different approaches.

In [Figure 60](#), a transformer is used after the amplifier to convert the signal to differential. The advantage of this approach is fewer components are required. R_{OUT} and R_T are required for impedance matching the transformer.

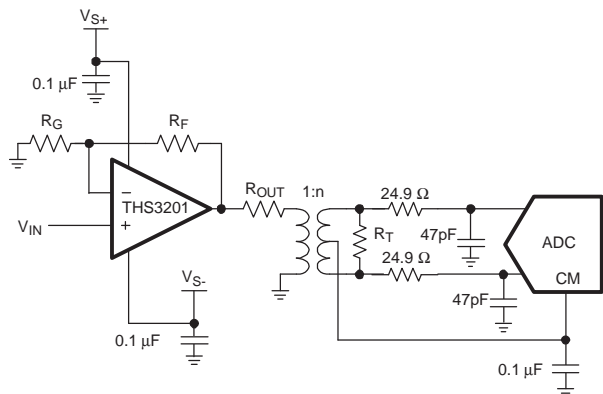

Figure 60. Differential ADC Driver Circuit 1

In [Figure 61](#), a transformer is used before two amplifiers to convert the signal to differential. The two amplifiers then amplify the differential signal. The advantage to this approach is each amplifier is required to drive one half the voltage as before. R_T is used to impedance match the transformer.

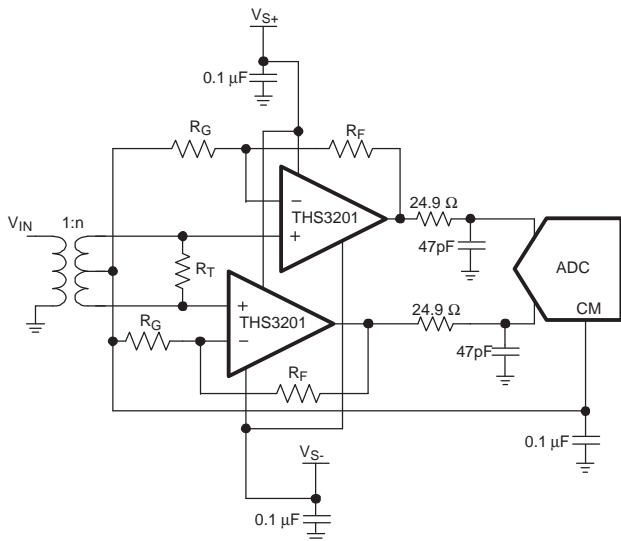

Figure 61. Differential ADC Driver Circuit 2

It is almost universally recommended to use a resistor and capacitor between the operational amplifier output and the ADC input as shown in Figure 60 and Figure 61.

This resistor-capacitor (RC) combination has multiple functions:

- The capacitor is a local charge reservoir for ADC.
- The resistor isolates the amplifier from the ADC.
- In conjunction, they form a low-pass noise filter.

During the sampling phase, current is required to charge the ADC input sampling capacitors. By placing external capacitors directly at the input pins, most of the current is drawn from them. They are seen as a low-impedance source. They can be thought of as serving much the same purpose as a power-supply bypass capacitor - to supply transient current - with the amplifier then providing the bulk charge.

Typically, a low-value capacitor in the range of 10 pF to 100 pF provides the required transient charge reservoir.

The capacitance and the switching action of the ADC is one of the worst loading scenarios that a high-speed amplifier encounters. The resistor provides a simple means of isolating the associated phase shift from the feedback network and maintaining the phase margin of the amplifier.

Typically, a low-value resistor in the range of 10 Ω to 100 Ω provides the required isolation. Together, the R and C form a real pole in the s-plane located at the frequency:

$$f_p = \frac{1}{2\pi RC}$$

Placing this pole at about 10x the highest frequency of interest ensures it has no impact on the signal. Since the resistor is typically a small value, it is bad practice to place the pole at (or near) frequencies of interest. At the pole frequency, the amplifiers see a load with a magnitude of:

$$\sqrt{2} \times R$$

If R is only 10 Ω, the amplifier is heavily loaded above the pole frequency, and generates excessive distortion.

DAC Driver Application

The THS3201 can be used as a high-performance DAC output driver in applications such as radio transmitter stages, and arbitrary waveform generators. All high-performance DACs have differential current outputs. Two THS3201s can be used as a differential drive amplifier in these applications as shown in Figure 62.

R_{PU} on the DAC output is used to convert the output current to voltage. The 24.9-Ω resistor and 47-pF capacitor between each DAC output and the operational amplifier input is used to reduce the images generated at multiples of the sampling rate. The values shown form a pole a 136 MHz. R_{OUT} sets the output impedance of each amplifier.

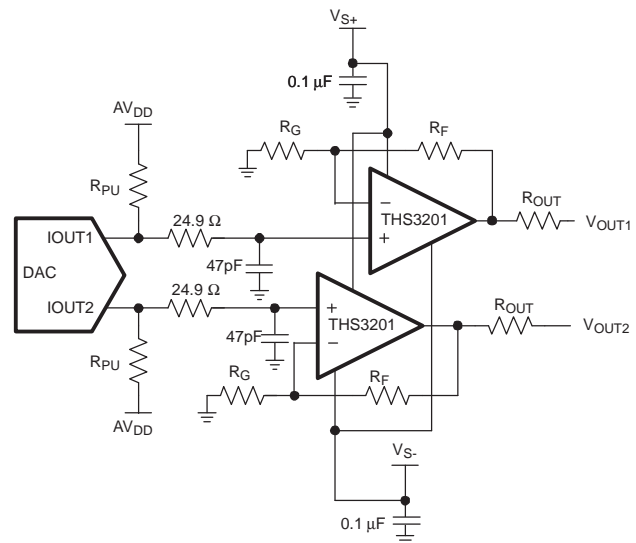

Figure 62. Differential DAC Driver Circuit

Printed-Circuit Board Layout Techniques for Optimal Performance

Achieving optimum performance with high-frequency amplifier-like devices in the THS3201 requires careful attention to board layout parasitic and external component types.

Recommendations that optimize performance include:

- Minimize parasitic capacitance to any power or ground plane for the negative input and output pins by voiding the area directly below these pins and connecting traces and the feedback path. Parasitic capacitance on the output and negative input pins can cause instability. To reduce unwanted capacitance, a window around the signal I/O pins should be opened in all of the ground and power planes around those pins and the feedback path. Otherwise, ground and power planes should be unbroken elsewhere on the board.
- Minimize the distance (<0.25 in) from the power-supply pins to high frequency 0.1- μ F and 100-pF decoupling capacitors. At the device pins, the ground and power-plane layout should not be in close proximity to the signal I/O pins. Avoid narrow power and ground traces to minimize inductance between the pins and the decoupling capacitors. The power-supply connections should always be decoupled with these capacitors. Larger (6.8 μ F or more) tantalum decoupling capacitors, effective at lower frequency, should also be used on the main supply pins. These may be placed somewhat farther from the device and may be shared among several devices in the same area of the PC board. The primary goal is to minimize the impedance seen in the differential-current return paths. For driving differential loads with the THS3201, adding a capacitor between the power-supply pins improves 2nd order harmonic distortion performance. This also minimizes the current loop formed by the differential drive.
- Careful selection and placement of external components preserve the high frequency performance of the THS3201. Resistors should be a low-reactance type. Surface-mount resistors work best and allow a tighter overall layout. Again, keep their leads and PC board trace length as short as possible. Never use wirebound-type resistors in a high-frequency application. Since the output pin and inverting input pins are the most sensitive to parasitic capacitance, always position the feedback and series output resistors, if any, as close as possible to the inverting input pins and output pins. Other network components, such as input termination resistors, should be placed close to the gain-setting resistors. Even with a low-parasitic capacitance shunting the external resistors, excessively high resistor values can create significant time constants that can degrade performance. Good axial metal-film or surface-mount resistors have approximately 0.2 pF in shunt with the resistor. For resistor values >2 k Ω , this parasitic capacitance can add a pole and/or a zero that can effect circuit operation. Keep resistor values as low as possible, consistent with load driving considerations.
- Connections to other wideband devices on the board may be made with short direct traces or through onboard transmission lines. For short connections, consider the trace and the input to the next device as a lumped capacitive load. Relatively wide traces (50 mils to 100 mils) should be used, preferably with ground and power planes opened up around them. Estimate the total capacitive load and determine if isolation resistors on the outputs are necessary. Low parasitic capacitive loads (<4 pF) may not need an R_S since the THS3201 is nominally compensated to operate with a 2-pF parasitic load. Higher parasitic capacitive loads without an R_S are allowed as the signal gain increases (increasing the unloaded phase margin). If a long trace is required and the 6-dB signal loss intrinsic to a doubly-terminated transmission line is acceptable, implement a matched impedance transmission line using microstrip or stripline techniques (consult an ECL design handbook for these techniques).
- A 50- Ω environment is not necessary onboard and, in fact, a higher-impedance environment improves distortion as shown in the distortion versus load plots. With a characteristic board trace impedance based on board material and trace dimensions, a matching series resistor into the trace from the output of the THS3201 is used, as well as a terminating shunt resistor at the input of the destination device.
- Remember also that the terminating impedance is the parallel combination of the shunt resistor and the input impedance of the destination device; this total effective impedance should be set to match the trace impedance. If the 6-dB attenuation of a doubly-terminated transmission line is unacceptable, a long trace can be series-terminated at the source end only. Treat the trace as a capacitive load in this case. This does not preserve signal integrity as well as a doubly-terminated line. If the input impedance of the destination device is low, there is some signal attenuation due to the voltage divider formed by the series output into the terminating impedance.
- Socketing a high-speed part such as the THS3201 is not recommended. The additional lead length and pin-to-pin capacitance introduced by the socket can create an extremely troublesome parasitic network, which can make it almost

impossible to achieve a smooth, stable frequency response. Best results are obtained by soldering THS3201 parts directly onto the board.

PowerPAD Design Considerations

The THS3201 is available in a thermally-enhanced PowerPAD family of packages. These packages are constructed using a downset leadframe upon which the die is mounted [see Figure 63(a) and Figure 63(b)]. This arrangement results in the lead frame being exposed as a thermal pad on the underside of the package [see Figure 63(c)]. Because this thermal pad has direct thermal contact with the die, excellent thermal performance can be achieved by providing a good thermal path away from the thermal pad.

The PowerPAD package allows for both assembly and thermal management in one manufacturing operation. During the surface-mount solder operation (when the leads are being soldered), the thermal pad can also be soldered to a copper area underneath the package. Through the use of thermal paths within this copper area, heat can be conducted away from the package into either a ground plane or other heat-dissipating device.

The PowerPAD package represents a breakthrough in combining the small area and ease of assembly of surface mount with the, heretofore, awkward mechanical methods of heatsinking.

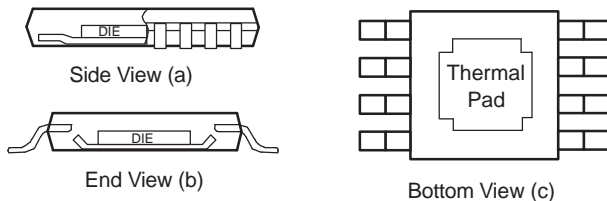

Figure 63. Views of Thermally Enhanced Package

Although there are many ways to properly heat sink the PowerPAD package, the following steps define the recommended approach.

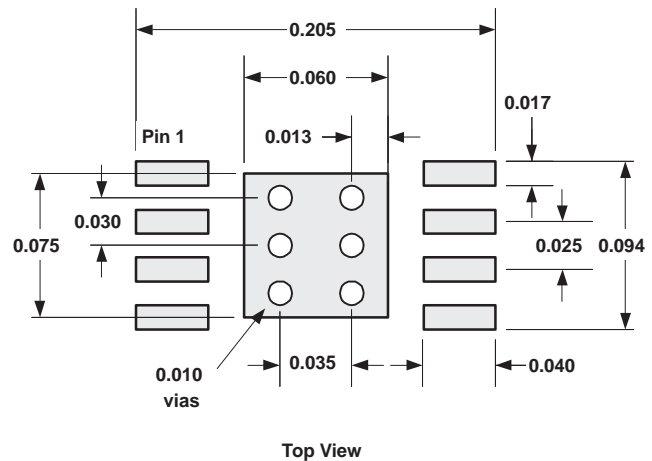

Figure 64. DGN PowerPAD PCB Etch and Via Pattern

PowerPAD PCB Layout Considerations

1. Prepare the PCB with a top-side etch pattern as shown in Figure 64. There should be etch for the leads as well as etch for the thermal pad.
2. Place five holes in the area of the thermal pad. These holes should be 10 mils in diameter. Keep them small so that solder wicking through the holes is not a problem during reflow.
3. Additional vias may be placed anywhere along the thermal plane outside of the thermal-pad area. This helps dissipate the heat generated by the THS3201 IC. These additional vias may be larger than the 10-mil diameter vias directly under the thermal-pad. They can be larger because they are not in the thermal pad area to be soldered so that wicking is not a problem.
4. Connect all holes to the internal ground plane.
5. When connecting these holes to the ground plane, **do not** use the typical web or spoke via connection methodology. Web connections have a high thermal resistance connection that is useful for slowing the heat transfer during soldering operations. This makes the soldering of vias that have plane connections easier. In this application, however, low thermal resistance is desired for the most efficient heat transfer. Therefore, the holes under the THS3201 PowerPAD package should make their connection to the internal ground plane with a complete connection around the entire circumference of the plated-through hole.
6. The top-side solder mask should leave the terminals of the package and the thermal-pad area with its five holes exposed. The bottom-side solder mask should cover the five holes of the thermal-pad area. This prevents solder from

being pulled away from the thermal-pad area during the reflow process.

7. Apply solder paste to the exposed thermal-pad area and all of the IC terminals.
8. With these preparatory steps in place, the IC is simply placed in position and run through the solder reflow operation as any standard surface-mount component. This results in a part that is properly installed.

Power Dissipation and Thermal Considerations

To maintain maximum output capabilities, the THS3201 does not incorporate automatic thermal shutoff protection. The designer must take care to ensure that the design does not violate the absolute maximum junction temperature of the device. Failure may result if the absolute maximum junction temperature of 150°C is exceeded. For the best performance, design for a maximum junction temperature of 125°C. Between 125°C and 150°C, damage does not occur, but the performance of the amplifier begins to degrade.

The thermal characteristics of the device are dictated by the package and the PC board. Maximum power dissipation for a given package can be calculated using the following formula.

$$P_{Dmax} = \frac{T_{max} - T_A}{\theta_{JA}}$$

where:

P_{Dmax} is the maximum power dissipation in the amplifier (W).

T_{max} is the absolute maximum junction temperature (°C).

T_A is the ambient temperature (°C).

$\theta_{JA} = \theta_{JC} + \theta_{CA}$

θ_{JC} is the thermal coefficient from the silicon junctions to the case (°C/W).

θ_{CA} is the thermal coefficient from the case to ambient air (°C/W).

For systems where heat dissipation is more critical, the THS3201 is offered in an 8-pin MSOP with PowerPAD and the THS3201 is available in the SOIC-8 PowerPAD package offering even better thermal performance. The thermal coefficient for the PowerPAD packages are substantially improved over the traditional SOIC. Maximum power dissipation levels are listed in the Dissipation Ratings table.. The data for the PowerPAD packages assume a board layout that follows the PowerPAD layout guidelines referenced above and detailed in the PowerPAD application report SLMA002. Figure 65 also shows

the effect of not soldering the PowerPAD to a PCB. The thermal impedance increases substantially, which may cause serious heat and performance issues. Be sure to always solder the PowerPAD to the PCB for optimum performance.

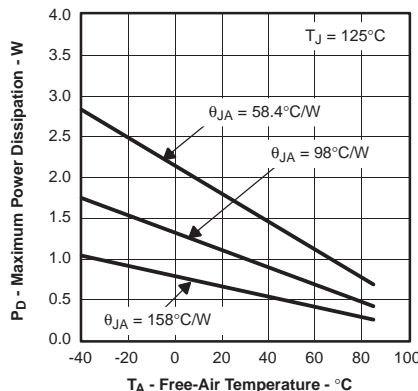

Results are With No Air Flow and PCB Size = 3"x3"
 $\theta_{JA} = 58.4^{\circ}\text{C/W}$ for 8-Pin MSOP w/PowerPad (DGN)
 $\theta_{JA} = 98^{\circ}\text{C/W}$ for 8-Pin SOIC High Test PCB (D)
 $\theta_{JA} = 158^{\circ}\text{C/W}$ for 8-Pin MSOP w/PowerPad w/o Solder

Figure 65. Maximum Power Dissipation vs Ambient Temperature

When determining whether or not the device satisfies the maximum power-dissipation requirement, it is important to not only consider quiescent power dissipation, but also dynamic power dissipation. Often times, this is difficult to quantify because the signal pattern is inconsistent, but an estimate of the RMS power dissipation can provide visibility into a possible problem.

Design Tools

Evaluation Fixture, Spice Models, and Applications Support

TI is committed to providing its customers with the highest quality of applications support. To support this goal, an evaluation board has been developed for the THS3201 operational amplifier. The board is easy to use, allowing for straightforward evaluation of the device. The evaluation board can be ordered through the TI web site, www.ti.com, or through your local TI sales representative. The schematic diagram, board layers, and bill of materials of the evaluation boards are in [Figure 66](#) through [Figure 70](#).

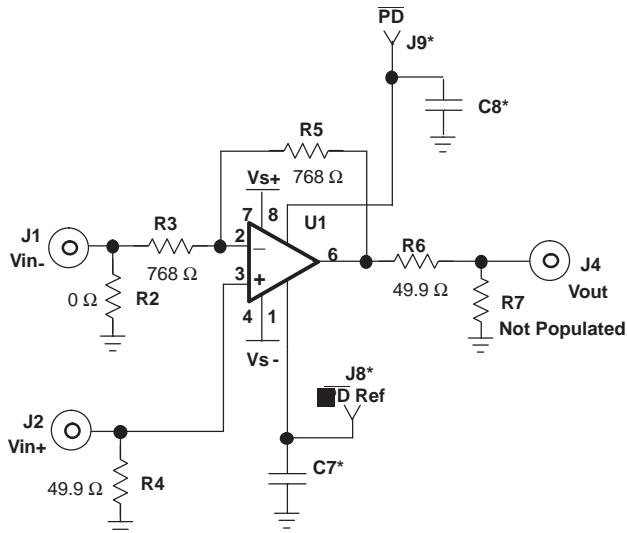

*Does Not Apply to the THS3201

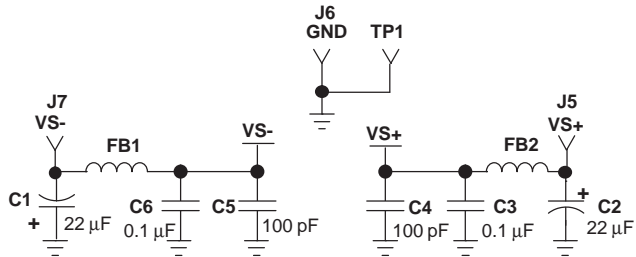

Figure 66. THS3201 EVM Circuit Configuration

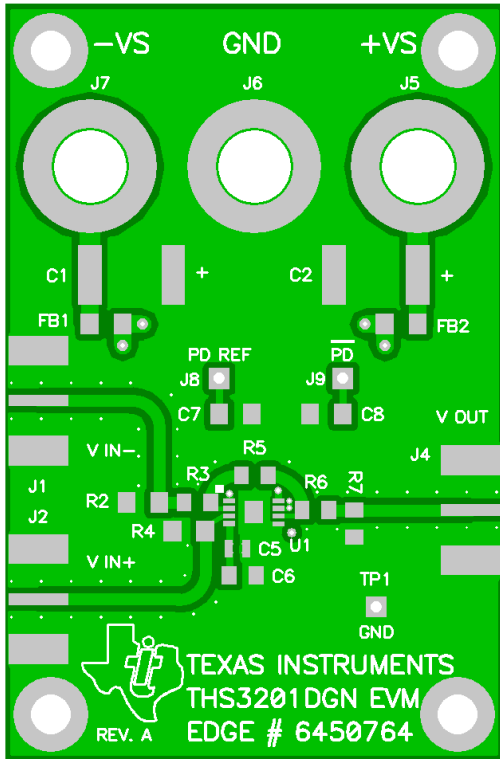

Figure 67. THS3201 EVM Board Layout (Top Layer)

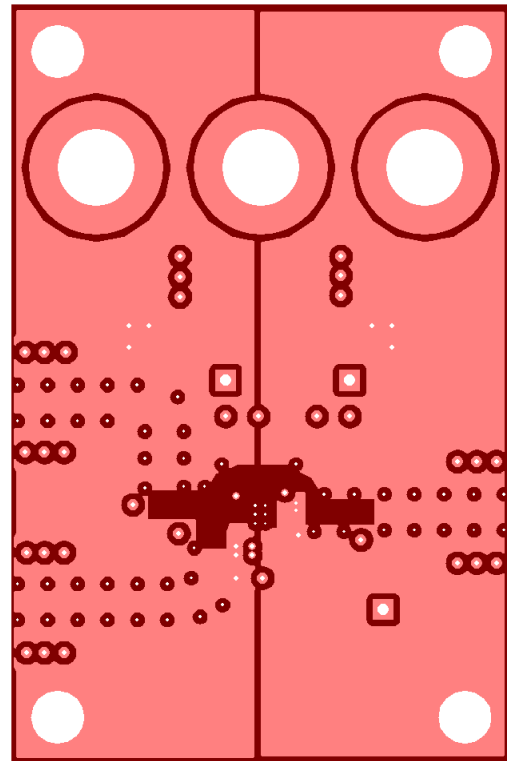

Figure 69. THS3201 EVM Board Layout (Third Layer, Power)

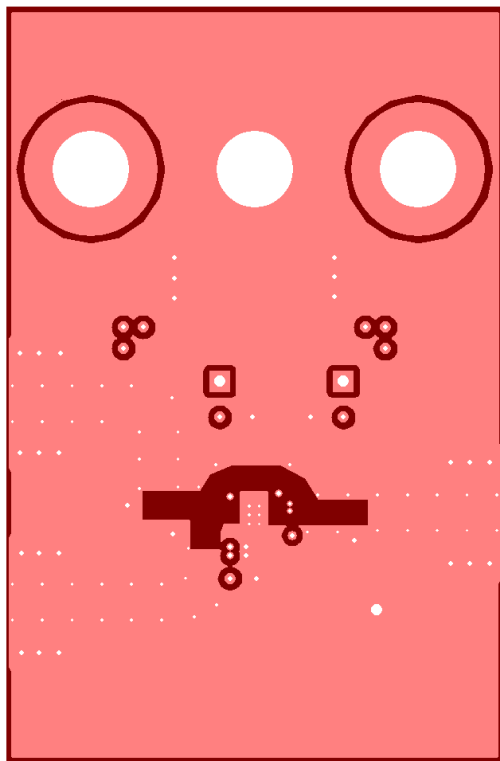

Figure 68. THS3201 EVM Board Layout (Second Layer, Ground)

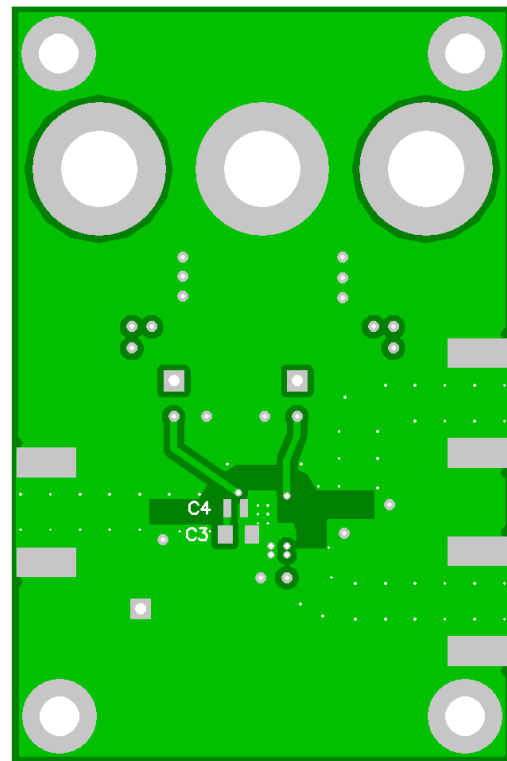

Figure 70. THS3201 EVM Board Layout (Bottom Layer)

Table 2. Bill of Materials⁽¹⁾

| THS3201DGN EVM | | | | | |
|----------------|--|----------|------------|--------------|--|
| ITEM | DESCRIPTION | SMD SIZE | REF DES | PCB QUANTITY | MANUFACTURER PART NUMBER |
| 1 | Bead, ferrite, 3 A, 80 Ω | 1206 | FB1, FB2 | 2 | (Steward) HI1206N800R-00 |
| 2 | Cap, 22 F, tanatalum, 25 V, 10% | D | C1, C2 | 2 | (AVX) TAJD226K025R |
| 3 | Cap, 100 pF, ceramic, 5%, 150 V | AQ12 | C4, C5 | 2 | (AVX) AQ12EM101JAJME |
| 4 | Cap, 0.1 F, ceramic, X7R, 50 V | 0805 | C3, C6 | 2 | (AVX) 08055C104KAT2A |
| 6 | Open | 0805 | R7 | 1 | |
| 7 | Resistor, 49.9 Ω , 1/8 W, 1% | 0805 | R6 | 1 | (Phycomp) 9C08052A49R9FKHFT |
| 9 | Resistor, 768 Ω , 1/8 W, 1% | 0805 | R3, R5 | 2 | (Phycomp) 9C08052A7680FKHFT |
| 10 | Open | 1206 | C7, C8 | 2 | |
| 11 | Resistor, 0 Ω , 1/4 W, 1% | 1206 | R2 | 1 | (KOA) RK73Z2BLTD |
| 12 | Resistor, 49.9 Ω , 1/4 W, 1% | 1206 | R4 | 1 | (Phycomp) 9C12063A49R9FKRFT |
| 13 | Test point, black | | TP1 | 1 | (Keystone) 5001 |
| 14 | Open | | J8, J9 | 2 | |
| 15 | Jack, Banana Receptance, 0.25" dia. hole | | J5, J6, J7 | 3 | (HH Smith) 101 |
| 16 | Connector, edge, SMA PCB jack | | J1, J2, J4 | 3 | (Johnson) 142-0701-801 |
| 17 | Standoff, 4-40 hex, 0.625" length | | | 4 | (Keystone) 1804 |
| 18 | Screw, Phillips, 4-40, .250" | | | 4 | SHR-0440-016-SN |
| 19 | IC, THS3201 | | U1 | 1 | (Texas Instruments) THS3201DGN |
| 20 | Board, printed circuit | | | 1 | (Texas Instruments) Edge # 6447972 Rev.A |

(1) The components shown in the BOM were used in test by TI. Computer simulation of circuit performance using SPICE is often useful when analyzing the performance of analog circuits and systems. This is particularly true for video and R_F -amplifier circuits, where parasitic capacitance and inductance can have a major effect on circuit performance. A SPICE model for the THS4500 family of devices is available through the TI web site (www.ti.com). The Product Information Center (PIC) is available for design assistance and detailed product information. These models do a good job of predicting small-signal ac and transient performance under a wide variety of operating conditions. They are not intended to model the distortion characteristics of the amplifier, nor do they attempt to distinguish between the package types in their small-signal ac performance. Detailed information about what is and is not modeled is contained in the model file itself.

Additional Reference Material

- PowerPAD™ Made Easy, application brief (SLMA004)
- PowerPAD™ Thermally-Enhanced Package, technical brief (SLMA002)
- Voltage Feedback vs Current Feedback Amplifiers (SLVA051)
- Current Feedback Analysis and Compensation (SLOA021)
- Current Feedback Amplifiers: Review, Stability, and Application (SBOA081)
- Effect of Parasitic Capacitance in Op Amp Circuits (SLOA013)

PACKAGING INFORMATION

| Orderable Device | Status ⁽¹⁾ | Package Type | Package Drawing | Pins | Package Qty | Eco Plan ⁽²⁾ | Lead/Ball Finish | MSL Peak Temp ⁽³⁾ |
|------------------|-----------------------|----------------|-----------------|------|-------------|-------------------------|------------------|------------------------------|
| THS3201MDGNREP | ACTIVE | MSOP-Power PAD | DGN | 8 | 2500 | Green (RoHS & no Sb/Br) | CU NIPDAU | Level-1-260C-UNLIM |
| V62/05609-01YE | ACTIVE | MSOP-Power PAD | DGN | 8 | 2500 | Green (RoHS & no Sb/Br) | CU NIPDAU | Level-1-260C-UNLIM |

⁽¹⁾ The marketing status values are defined as follows:

ACTIVE: Product device recommended for new designs.

LIFEBUY: TI has announced that the device will be discontinued, and a lifetime-buy period is in effect.

NRND: Not recommended for new designs. Device is in production to support existing customers, but TI does not recommend using this part in a new design.

PREVIEW: Device has been announced but is not in production. Samples may or may not be available.

OBSOLETE: TI has discontinued the production of the device.

⁽²⁾ Eco Plan - The planned eco-friendly classification: Pb-Free (RoHS), Pb-Free (RoHS Exempt), or Green (RoHS & no Sb/Br) - please check <http://www.ti.com/productcontent> for the latest availability information and additional product content details.

TBD: The Pb-Free/Green conversion plan has not been defined.

Pb-Free (RoHS): TI's terms "Lead-Free" or "Pb-Free" mean semiconductor products that are compatible with the current RoHS requirements for all 6 substances, including the requirement that lead not exceed 0.1% by weight in homogeneous materials. Where designed to be soldered at high temperatures, TI Pb-Free products are suitable for use in specified lead-free processes.

Pb-Free (RoHS Exempt): This component has a RoHS exemption for either 1) lead-based flip-chip solder bumps used between the die and package, or 2) lead-based die adhesive used between the die and leadframe. The component is otherwise considered Pb-Free (RoHS compatible) as defined above.

Green (RoHS & no Sb/Br): TI defines "Green" to mean Pb-Free (RoHS compatible), and free of Bromine (Br) and Antimony (Sb) based flame retardants (Br or Sb do not exceed 0.1% by weight in homogeneous material)

⁽³⁾ MSL, Peak Temp. -- The Moisture Sensitivity Level rating according to the JEDEC industry standard classifications, and peak solder temperature.

Important Information and Disclaimer:The information provided on this page represents TI's knowledge and belief as of the date that it is provided. TI bases its knowledge and belief on information provided by third parties, and makes no representation or warranty as to the accuracy of such information. Efforts are underway to better integrate information from third parties. TI has taken and continues to take reasonable steps to provide representative and accurate information but may not have conducted destructive testing or chemical analysis on incoming materials and chemicals. TI and TI suppliers consider certain information to be proprietary, and thus CAS numbers and other limited information may not be available for release.

In no event shall TI's liability arising out of such information exceed the total purchase price of the TI part(s) at issue in this document sold by TI to Customer on an annual basis.

OTHER QUALIFIED VERSIONS OF THS3201-EP :

- Catalog: [THS3201](#)

NOTE: Qualified Version Definitions:

- Catalog - TI's standard catalog product

DGN (S-PDSO-G8)

PowerPAD™ PLASTIC SMALL OUTLINE

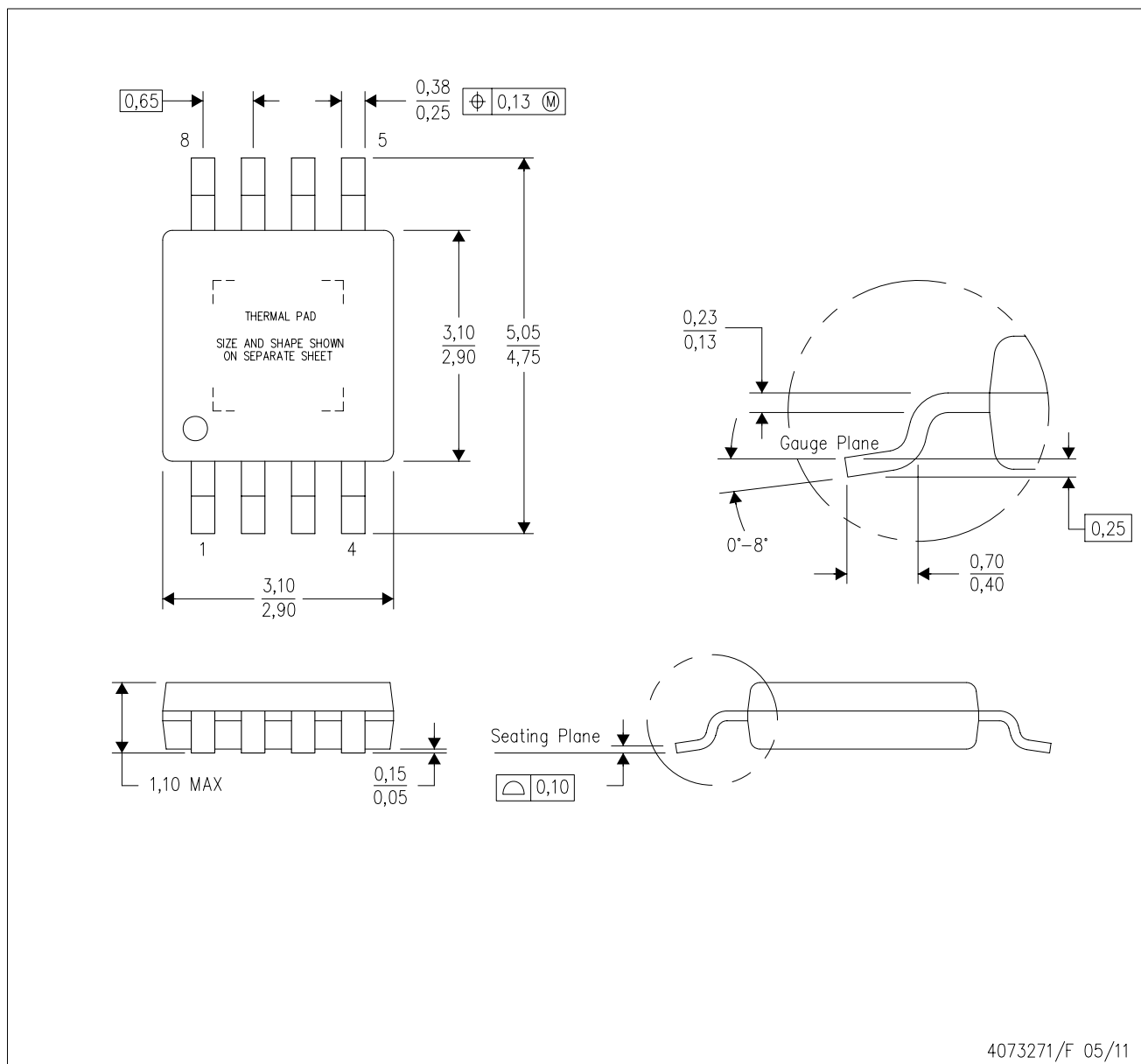

- NOTES:
- All linear dimensions are in millimeters.
 - This drawing is subject to change without notice.
 - Body dimensions do not include mold flash or protrusion.
 - This package is designed to be soldered to a thermal pad on the board. Refer to Technical Brief, PowerPad Thermally Enhanced Package, Texas Instruments Literature No. SLMA002 for information regarding recommended board layout. This document is available at www.ti.com <<http://www.ti.com>>.
 - See the additional figure in the Product Data Sheet for details regarding the exposed thermal pad features and dimensions.
 - Falls within JEDEC MO-187 variation AA-T

PowerPAD is a trademark of Texas Instruments.

IMPORTANT NOTICE

Texas Instruments Incorporated and its subsidiaries (TI) reserve the right to make corrections, modifications, enhancements, improvements, and other changes to its products and services at any time and to discontinue any product or service without notice. Customers should obtain the latest relevant information before placing orders and should verify that such information is current and complete. All products are sold subject to TI's terms and conditions of sale supplied at the time of order acknowledgment.

TI warrants performance of its hardware products to the specifications applicable at the time of sale in accordance with TI's standard warranty. Testing and other quality control techniques are used to the extent TI deems necessary to support this warranty. Except where mandated by government requirements, testing of all parameters of each product is not necessarily performed.

TI assumes no liability for applications assistance or customer product design. Customers are responsible for their products and applications using TI components. To minimize the risks associated with customer products and applications, customers should provide adequate design and operating safeguards.

TI does not warrant or represent that any license, either express or implied, is granted under any TI patent right, copyright, mask work right, or other TI intellectual property right relating to any combination, machine, or process in which TI products or services are used. Information published by TI regarding third-party products or services does not constitute a license from TI to use such products or services or a warranty or endorsement thereof. Use of such information may require a license from a third party under the patents or other intellectual property of the third party, or a license from TI under the patents or other intellectual property of TI.

Reproduction of TI information in TI data books or data sheets is permissible only if reproduction is without alteration and is accompanied by all associated warranties, conditions, limitations, and notices. Reproduction of this information with alteration is an unfair and deceptive business practice. TI is not responsible or liable for such altered documentation. Information of third parties may be subject to additional restrictions.

Resale of TI products or services with statements different from or beyond the parameters stated by TI for that product or service voids all express and any implied warranties for the associated TI product or service and is an unfair and deceptive business practice. TI is not responsible or liable for any such statements.

TI products are not authorized for use in safety-critical applications (such as life support) where a failure of the TI product would reasonably be expected to cause severe personal injury or death, unless officers of the parties have executed an agreement specifically governing such use. Buyers represent that they have all necessary expertise in the safety and regulatory ramifications of their applications, and acknowledge and agree that they are solely responsible for all legal, regulatory and safety-related requirements concerning their products and any use of TI products in such safety-critical applications, notwithstanding any applications-related information or support that may be provided by TI. Further, Buyers must fully indemnify TI and its representatives against any damages arising out of the use of TI products in such safety-critical applications.

TI products are neither designed nor intended for use in military/aerospace applications or environments unless the TI products are specifically designated by TI as military-grade or "enhanced plastic." Only products designated by TI as military-grade meet military specifications. Buyers acknowledge and agree that any such use of TI products which TI has not designated as military-grade is solely at the Buyer's risk, and that they are solely responsible for compliance with all legal and regulatory requirements in connection with such use.

TI products are neither designed nor intended for use in automotive applications or environments unless the specific TI products are designated by TI as compliant with ISO/TS 16949 requirements. Buyers acknowledge and agree that, if they use any non-designated products in automotive applications, TI will not be responsible for any failure to meet such requirements.

Following are URLs where you can obtain information on other Texas Instruments products and application solutions:

Products

| | |
|-----------------------------|--|
| Audio | www.ti.com/audio |
| Amplifiers | amplifier.ti.com |
| Data Converters | dataconverter.ti.com |
| DLP® Products | www.dlp.com |
| DSP | dsp.ti.com |
| Clocks and Timers | www.ti.com/clocks |
| Interface | interface.ti.com |
| Logic | logic.ti.com |
| Power Mgmt | power.ti.com |
| Microcontrollers | microcontroller.ti.com |
| RFID | www.ti-rfid.com |
| RF/IF and ZigBee® Solutions | www.ti.com/lprf |

Applications

| | |
|-------------------------------|--|
| Communications and Telecom | www.ti.com/communications |
| Computers and Peripherals | www.ti.com/computers |
| Consumer Electronics | www.ti.com/consumer-apps |
| Energy and Lighting | www.ti.com/energy |
| Industrial | www.ti.com/industrial |
| Medical | www.ti.com/medical |
| Security | www.ti.com/security |
| Space, Avionics and Defense | www.ti.com/space-avionics-defense |
| Transportation and Automotive | www.ti.com/automotive |
| Video and Imaging | www.ti.com/video |
| Wireless | www.ti.com/wireless-apps |

TI E2E Community Home Page

e2e.ti.com

Mailing Address: Texas Instruments, Post Office Box 655303, Dallas, Texas 75265
Copyright © 2011, Texas Instruments Incorporated

www.BDTIC.com/TI