

### FEATURES

- 500 MHz Driver Operation
- Driver Inhibit Function
- 100 ps Edge Matching
- Guaranteed Industry Specifications
  - 50  $\Omega$  Output Impedance
  - >1.5 V/ns Slew Rate
- Variable Output Voltages for ECL, TTL and CMOS
- High Speed Differential Inputs for Maximum Flexibility
- Ultrasmall 20-Lead SOP Package with Built-In Heat Sink

### APPLICATIONS

- Automatic Test Equipment
- Semiconductor Test Systems
- Board Test Systems
- Instrumentation and Characterization Equipment

### FUNCTIONAL BLOCK DIAGRAM

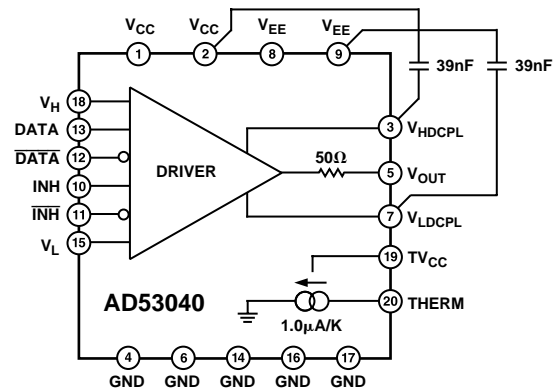

### PRODUCT DESCRIPTION

The AD53040 is a complete high speed pin driver designed for use in digital or mixed-signal test systems. Combining a high speed monolithic process with a unique surface mount package, this product attains superb electrical performance while preserving optimum packaging densities and long-term reliability in an ultrasmall 20-lead, SOP package with built-in heat sink.

Featuring unity gain programmable output levels of  $-3$  V to  $+8$  V, with output swing capability of less than 100 mV to 9 V, the AD53040 is designed to stimulate ECL, TTL and CMOS logic families. The 500 MHz data rate capacity and matched output impedance allows for real-time stimulation of these digital logic families. To test I/O devices, the pin driver can be switched into a high impedance state (Inhibit Mode), electrically removing the driver from the path. The pin driver leakage current inhibit is typically 100 nA and output charge transfer entering inhibit is typically less than 20 pC.

The AD53040 transition from HI/LO or to inhibit is controlled through the data and inhibit inputs. The input circuitry uses high speed differential inputs with a common-mode range of  $\pm 3$  V. This allows for direct interface to precision differential ECL timing or the simplicity of stimulating the pin driver from a single ended TTL or CMOS logic source. The analog logic HI/LO inputs are equally easy to interface. Typically requiring 10  $\mu$ A of bias current, the AD53040 can be directly coupled to the output of a digital-to-analog converter.

The AD53040 is available in a 20-lead, SOP package with a built-in heat sink and is specified to operate over the ambient commercial temperature range of  $-25^{\circ}\text{C}$  to  $+85^{\circ}\text{C}$ .

### REV. B

Information furnished by Analog Devices is believed to be accurate and reliable. However, no responsibility is assumed by Analog Devices for its use, nor for any infringements of patents or other rights of third parties which may result from its use. No license is granted by implication or otherwise under any patent or patent rights of Analog Devices.

# AD53040—SPECIFICATIONS

(All specifications are at  $T_J = +85^\circ\text{C} \pm 5^\circ\text{C}$ ,  $+V_S = +12\text{ V} \pm 3\%$ ,  $-V_S = -7\text{ V} \pm 3\%$  unless otherwise noted. All temperature coefficients are measured at  $T_J = +75^\circ\text{C} - 95^\circ\text{C}$ ). (A 39 nF capacitor must be connected between  $V_{CC}$  and  $V_{HDCPL}$  and between  $V_{EE}$  and  $V_{LDCPL}$ .)

Parameter	Min	Typ	Max	Units	Test Conditions
<b>DIFFERENTIAL INPUT CHARACTERISTICS</b>					
Input Swing (Data to $\overline{\text{DATA}}$ , INH to $\overline{\text{INH}}$ )		ECL	2	Volts	
Max (DATA, $\overline{\text{DATA}}$ ) to Min (INH, $\overline{\text{INH}}$ )			2	Volts	
Max (INH, $\overline{\text{INH}}$ ) to Min (Data, $\overline{\text{DATA}}$ )				Volts	
Bias Current		$\pm 10$		$\mu\text{A}$	$V_{IN} = -2\text{ V}, 0.0\text{ V}$
<b>REFERENCE INPUTS</b>					
Bias Currents	-50		+50	$\mu\text{A}$	$V_L, V_H = 5\text{ V}$
<b>OUTPUT CHARACTERISTICS</b>					
Logic High Range	-2		+8	Volts	DATA = H, $V_H = -2\text{ V}$ to +8 V $V_L = -3\text{ V}$ ( $V_H = -2\text{ V}$ to +6 V) $V_L = -1\text{ V}$ ( $V_H = +6\text{ V}$ to +8 V)
Logic Low Range	-3		+5	Volts	DATA = L, $V_L = -3\text{ V}$ to +5 V, $V_H = +6\text{ V}$
Amplitude ( $V_H$ and $V_L$ )	0.1		9	Volts	$V_L = -0.05\text{ V}, V_H = +0.05\text{ V}$ and $V_L = -2\text{ V}, V_H = +7\text{ V}$
Absolute Accuracy					
$V_H$ Offset	-100		+100	mV	DATA = H, $V_H = -2\text{ V}$ to +8 V, $V_L = -3\text{ V}$
$V_H$ Gain + Linearity Error		$\pm 0.3 \pm 5$		% of $V_H$ + mV	DATA = H, $V_H = -2\text{ V}$ to +8 V, $V_L = -3\text{ V}$
$V_L$ Offset	-100		+100	mV	DATA = L, $V_L = -3\text{ V}$ to +5 V, $V_H = +6\text{ V}$
$V_L$ Gain + Linearity Error		$\pm 0.3 \pm 5$		% of $V_L$ + mV	DATA = L, $V_L = -3\text{ V}$ to +5 V, $V_H = +6\text{ V}$
Offset TC, $V_H$ or $V_L$		0.5		mV/ $^\circ\text{C}$	$V_L, V_H = 0\text{ V}, +5\text{ V}$ and $-3\text{ V}, 0\text{ V}$
Output Resistance	45	47	49	$\Omega$	DATA = H, $V_H = +3\text{ V}, V_L = 0\text{ V}$ , $I_{OUT} = 30\text{ mA}$
Output Leakage	-1.0		+1.0	$\mu\text{A}$	$V_{OUT} = -3\text{ V}$ to +8 V
Dynamic Current Limit		150		mA	$C_{BYP} = 39\text{ nF}, V_H = +7\text{ V}, V_L = -2\text{ V}$
Static Current Limit		$\pm 65$		mA	Output to $-3\text{ V}, V_H = +8\text{ V}, V_L = -1\text{ V}$ , DATA = H and Output to +8 V, $V_H = +6\text{ V}$ , $V_L = -3\text{ V}, \text{DATA} = \text{L}$
PSRR, Drive Mode		35		dB	$V_S = V_S \pm 3\%$
<b>DYNAMIC PERFORMANCE, DRIVE (<math>V_H</math> and <math>V_L</math>)</b>					
Propagation Delay Time		1.5		ns	Measured at 50%, $V_H = +400\text{ mV}$ , $V_L = -400\text{ mV}$
Propagation Delay TC		2		ps/ $^\circ\text{C}$	Measured at 50%, $V_H = +400\text{ mV}$ , $V_L = -400\text{ mV}$
Delay Matching, Edge to Edge		100		ps	Measured at 50%, $V_H = +400\text{ mV}$ , $V_L = -400\text{ mV}$
Rise and Fall Time					
1 V Swing		0.8		ns	Measured 20%–80%, $V_L = 0\text{ V}, V_H = 1\text{ V}$
3 V Swing		1.7		ns	Measured 10%–90%, $V_L = 0\text{ V}, V_H = 3\text{ V}$
5 V Swing		2.4		ns	Measured 10%–90%, $V_L = 0\text{ V}, V_H = 5\text{ V}$
Rise and Fall Time TC					
1 V Swing		$\pm 1$		ps/ $^\circ\text{C}$	Measured 20%–80%, $V_L = 0\text{ V}, V_H = 1\text{ V}$
3 V Swing		$\pm 2$		ps/ $^\circ\text{C}$	Measured 10%–90%, $V_L = 0\text{ V}, V_H = 3\text{ V}$
5 V Swing		$\pm 3$		ps/ $^\circ\text{C}$	Measured 10%–90%, $V_L = 0\text{ V}, V_H = 5\text{ V}$
Overshoot, Undershoot and Preshoot		$\pm(1\% + 50\text{ mV})$		% of Step + mV	a. $V_L, V_H = 0.0\text{ V}, 1.0\text{ V}$ b. $V_L, V_H = 0.0\text{ V}, 3.0\text{ V}$ c. $V_L, V_H = 0.0\text{ V}, 5.0\text{ V}$
Settling Time					
to 15 mV		40		ns	$V_L = 0\text{ V}, V_H = 0.5\text{ V}$
to 4 mV		8		$\mu\text{s}$	$V_L = 0\text{ V}, V_H = 0.5\text{ V}$
Delay Change vs. Pulsewidth		50		ps	$V_L = 0\text{ V}, V_H = 2\text{ V}$ , Pulsewidth = 2.5 ns/7.5 ns, 30 ns/100 ns

Parameter	Min	Typ	Max	Units	Test Conditions
<b>DYNAMIC PERFORMANCE, DRIVE</b> ( $V_H$ and $V_L$ ) (Continued)					
Minimum Pulsewidth		1.7		ns	4.0 ns Input, 10%/90% Output, $V_L = 0$ V, $V_H = 3$ V
3 V Swing					
5 V Swing		2.6		ns	6.0 ns Input, 10%/90% Output, $V_L = 0$ V, $V_H = 5$ V
Toggle Rate		500		MHz	$V_L = -1.8$ V, $V_H = -0.8$ V, $V_{OUT} > 600$ mV p-p
<b>DYNAMIC PERFORMANCE, INHIBIT</b>					
Delay Time, Active to Inhibit	2		5	ns	Measured at 50%, $V_H = +2$ V, $V_L = -2$ V
Delay Time, Inhibit to Active	2		5	ns	Measured at 50%, $V_H = +2$ V, $V_L = -2$ V
I/O Spike		<200		mV, p-p	$V_H = 0$ V, $V_L = 0$ V
Output Capacitance		5		pF	Driver Inhibited
<b>POWER SUPPLIES</b>					
Total Supply Range		19		V	
Positive Supply		+12		V	
Negative Supply		-7		V	
Positive Supply Current			75	mA	
Negative Supply Current			75	mA	
Total Power Dissipation		1.15	1.43	W	
Temperature Sensor Gain Factor		1.0		$\mu$ A/K	$R_{LOAD} = 10$ K, $V_{SOURCE} = +12$ V

## NOTES

Connecting or shorting the decoupling capacitors to ground will result in the destruction of the device.

Specifications subject to change without notice.

## ABSOLUTE MAXIMUM RATINGS<sup>1</sup>

### Power Supply Voltage

+ $V_S$ to GND	+13 V
- $V_S$ to GND	-8 V
+ $V_S$ to - $V_S$	+20 V

### Inputs

DATA, $\overline{\text{DATA}}$ , INH, $\overline{\text{INH}}$	+5 V, -3 V
DATA to $\overline{\text{DATA}}$ , INH to $\overline{\text{INH}}$	$\pm 3$ V
$V_H$ , $V_L$ to GND	+9 V, -4 V
$V_H$ to $V_L$	+11 V, 0 V

### Outputs

$V_{OUT}$ Short Circuit Duration	Indefinite <sup>2</sup>
----------------------------------	-------------------------

### $V_{OUT}$ Range in Inhibit Mode

$V_{HDCPL}$	Do Not Connect Except for Capacitor to $V_{CC}$
$V_{LDCPL}$	Do Not Connect Except for Capacitor to $V_{EE}$
THERM	+13 V, 0 V

### Environmental

Operating Temperature (Junction)	+175°C
Storage Temperature	-65°C to +150°C
Lead Temperature (Soldering, 10 sec) <sup>3</sup>	+260°C

## CAUTION

ESD (electrostatic discharge) sensitive device. Electrostatic charges as high as 4000 V readily accumulate on the human body and test equipment and can discharge without detection. Although the AD53040 features proprietary ESD protection circuitry, permanent damage may occur on devices subjected to high energy electrostatic discharges. Therefore, proper ESD precautions are recommended to avoid performance degradation or loss of functionality.

## NOTES

<sup>1</sup>Stresses above those listed under Absolute Maximum Ratings may cause permanent damage to the device. This is a stress rating only; functional operation of the device at these or any other conditions above those indicated in the operational sections of this specification is not implied. Absolute maximum limits apply individually, not in combination. Exposure to absolute maximum rating conditions for extended periods may affect device reliability.

<sup>2</sup>Output short circuit protection is guaranteed as long as proper heat sinking is employed to ensure compliance with the operating temperature limits.

<sup>3</sup>To ensure lead coplanarity ( $\pm 0.002$  inches) and solderability, handling with bare hands should be avoided and the device should be stored in environments at 24°C  $\pm 5$ °C (75°F  $\pm 10$ °F) with relative humidity not to exceed 65%.

## ORDERING GUIDE

Model	Package Description	Shipment Method, Quantity Per Shipping Container	Package Option
AD53040KRP	20-Lead Power SOIC	Tube, 38 Pieces	RP-20



# AD53040

## PIN FUNCTION DESCRIPTIONS

Pin Name	Pin Number	Pin Functional Description
V <sub>CC</sub>	1, 2	Positive Power Supply. Both pins should be connected to minimize inductance and allow maximum speed of operation. V <sub>CC</sub> should be decoupled to GND with a low inductance 0.1 μF capacitor.
V <sub>EE</sub>	8, 9	Negative Power Supply. Both pins should be connected to keep the inductance down and allow maximum speed of operation. V <sub>EE</sub> should be decoupled to GND with a low inductance 0.1 μF capacitor.
GND	4, 6, 14, 16, 17	Device Ground. These pins should be connected to the circuit board's ground plane at the pins.
V <sub>L</sub>	15	Analog Input that sets the voltage level of a Logic 0 of the driver. Determines the driver output for DATA > DATA.
V <sub>H</sub>	18	Analog input that sets the voltage level of a Logic 1 of the driver. Determines the driver output for DATA > DATA.
V <sub>OUT</sub>	5	The Driver Output. The nominal output impedance is 50 Ω.
V <sub>HDCPL</sub>	3	Internal supply decoupling for the output stage. This pin is connected to V <sub>CC</sub> through a 39 nF minimum capacitors.
V <sub>LDCPL</sub>	7	Internal supply decoupling for the output stage. This pin is connected to V <sub>EE</sub> through a 39 nF minimum capacitors.
INH, INH	10, 11	ECL compatible input that control the high impedance state of the driver. When INH > INH, the driver goes into a high impedance state.
DATA, DATA	13, 12	ECL compatible inputs that determines the high and low state of the driver. Driver output is high for DATA > DATA.
TV <sub>CC</sub>	19	Temperature Sensor Start-Up Pin. This pin should be connected to V <sub>CC</sub> .
THERM	20	Temperature Sensor Output Pin. A resistor (10K) should be connected between THERM and V <sub>CC</sub> . The approximate die temperature can be determined by measuring the current through the resistor. The typical scale factor is 1 μA/K.

## PIN CONFIGURATION

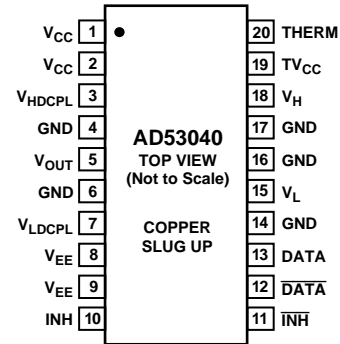

Table I. Pin Driver Truth Table

DATA	DATA	INH	INH	Output State
0	1	0	1	V <sub>L</sub>
1	0	0	1	V <sub>H</sub>
0	1	1	0	Hi-Z
1	0	1	0	Hi-Z

Table II. Package Thermal Characteristics

Air Flow, FM	θ <sub>JC</sub> , °C/W	θ <sub>JA</sub> , °C/W
0	4	50
50	4	49
400	4	34

## APPLICATION INFORMATION

### Power Supply Distribution, Bypassing and Sequencing

The AD53040 draws substantial transient currents from its power supplies when switching between states and careful design of the power distribution and bypassing is key to obtaining specified performance. Supplies should be distributed using broad, low inductance traces or (preferably) planes in a multilayered board with a dedicated ground-plane layer. All of the device's power supply pins should be used to minimize the internal inductance presented by the part's bond wires. Each supply must be bypassed to ground with at least one 0.1  $\mu\text{F}$  capacitor; chip-style capacitors are preferable as they minimize inductance. One or more 10  $\mu\text{F}$  (or greater) Tantalum capacitors per board are also advisable to provide additional local energy storage.

The AD53040's current-limit circuitry also requires external bypass capacitors. Figure 1 shows a simplified schematic of the positive current-limit circuit. Excessive collector current in output transistor Q49 creates a voltage drop across the 10  $\Omega$  resistor, which turns on PNP transistor Q48. Q48 diverts the rising-edge slew current, shutting down the current mirror and removing the output stage's base drive. The  $V_{\text{HDCPL}}$  pin should be bypassed to the positive supply with a 0.039  $\mu\text{F}$  capacitor, while the  $V_{\text{LDCPL}}$  pin (not shown) requires a similar capacitor to the negative supply—these capacitors ensure that the AD53040 doesn't current limit during normal output transitions up to its full 9 V rated step size. Both capacitors must have minimum-length connections to the AD53040. Here again, chip capacitors are ideal.

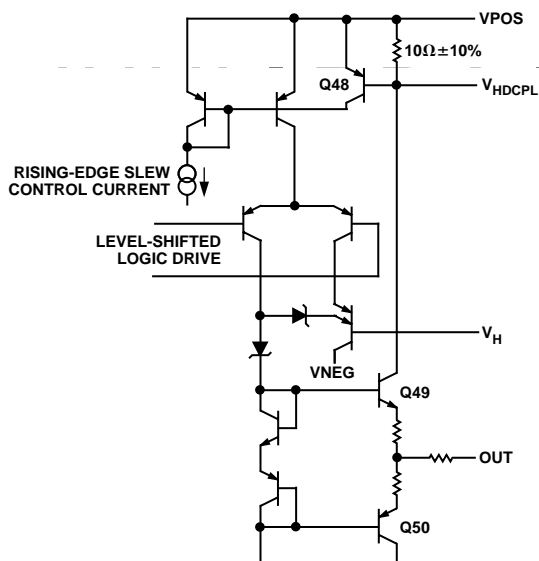

Figure 1. Simplified Schematic of the AD53040 Output Stage and Positive Current Limit Circuitry

Several points about the current-limit circuitry should be noted. First, the limiting currents are not tightly controlled, as they are functions of both absolute transistor  $V_{\text{BES}}$  and junction temperature; higher dc output current is available at lower junction temperatures. Second, it is essential to connect the  $V_{\text{HDCPL}}$  capacitor to the positive supply (and the  $V_{\text{LDCPL}}$  capacitor to the negative supply)—failure to do so causes considerable thermal stress in the current-limiting resistor(s) during normal supply sequencing and may ultimately cause them to fail, rendering the part nonfunctional. Finally, the AD53040 may appear to function normally for small output steps (less than 3 V or so) if one or both of these capacitors is absent, but it will exhibit excessive rise or fall times for steps of larger amplitude.

The AD53040 does not require special power-supply sequencing. However, good design practice dictates that digital and analog control signals not be applied to the part before the supplies are stable. Violating this guideline will not normally destroy the part, but the active inputs can draw considerable current until the main supplies are applied.

### Digital Input Range Restrictions

Total range amongst all digital signals ( $\text{DATA}$ ,  $\overline{\text{DATA}}$ ,  $\text{INH}$ , and  $\overline{\text{INH}}$ ) has to be less than or equal to 2 V to meet specified timing. The device will function above 2 V with reduced performance up to the absolute maximum limit. This performance degradation might not be noticed in all modes of operation. Of all the six possible transitions ( $V_{\text{H}} \rightarrow V_{\text{L}}$ ,  $V_{\text{L}} \rightarrow V_{\text{H}}$ ,  $V_{\text{H}} \rightarrow \text{INH}$ ,  $\text{INH} \rightarrow V_{\text{H}}$ ,  $V_{\text{L}} \rightarrow \text{INH}$  and  $\text{INH} \rightarrow V_{\text{L}}$ ), there may be only one that would show a degradation, usually in delay time. Taken to the extreme, the driver may fail to achieve a proper output voltage, output impedance or may fail to fully inhibit.

An example of a scenario that would not work for the AD53040 is if the part is driven using 5 V single-ended CMOS. One pin of each differential input would be tied to a +2.5 V reference level and the logic voltages would be applied to the other. This would meet the Absolute Maximum Rating of  $\pm 3$  V because the max differential is  $\pm 2.5$  V. It is however possible, for example for 0.0 V to be applied to the  $\text{INH}$  input and +5 V to be applied to the  $\text{DATA}$  input. This 5 V difference far exceeds the 2.0 V limitation given above. Even using 3 V CMOS or TTL the difference between logic high and logic low is greater than or equal to 3 V which will not properly work. The only solution is to use resistive dividers or equivalent to reduce the voltage levels.

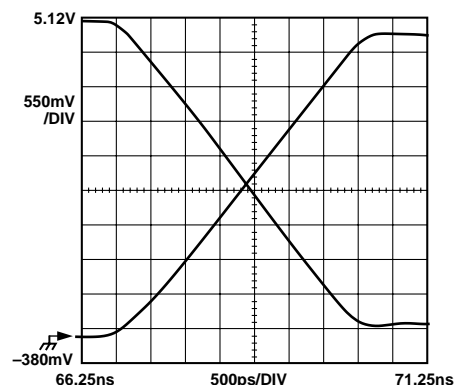

Figure 2. 5 V Output Swing

# AD53040

**NOTE:**

1. 50Ω TERMINATION TO BE AS CLOSE TO RECEIVER AS POSSIBLE. (END OF TRACE MARKED BY \*) THROUGH SMA CONNECTS BETWEEN MC10EL16 OUTPUTS AND DUT.
2. NO VIAS ALLOWED ON VOUT LINE.
3. SMA ON V<sub>OUT</sub> TO BE MOUNTED ON ITS SIDE FOR BEST IMPEDANCE MATCH.
4. ONE DIMENSION OF BOARD TO BE 4-1/2 INCHES.
5. DUT PACKAGE IS TO BE CENTERED ON BOARD.
6. ALL RESISTORS AND NONELECTROLYTIC CAPS ARE 0805-SIZE SURFACE MOUNT.
7. SEE DATA SHEET FOR HIDDEN POWER AND GROUND PINS ON LOGIC GATES.
8. ALL 100nF BYPASS CAPACITORS TO BE LOCATED CLOSE TO PACKAGE.
9. PCB IS TO BE 4-LAYER WITH POWER GND (⊥) AND -2V AS INNER PLANES.

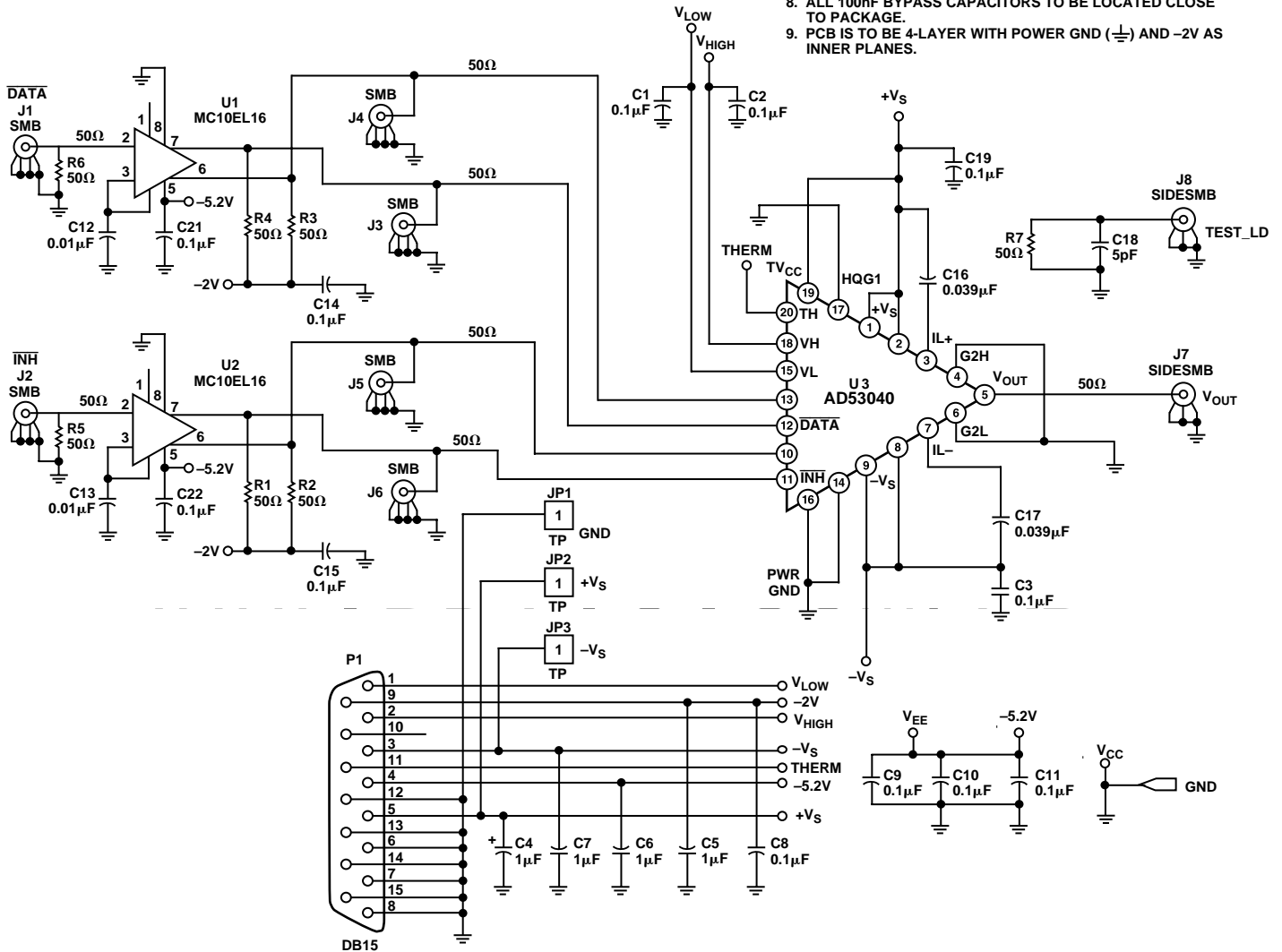
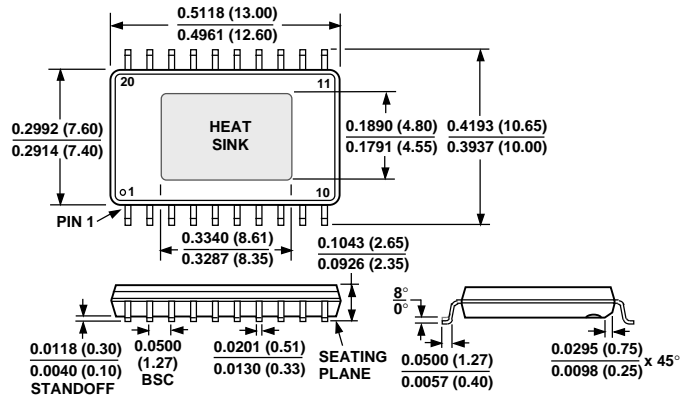

Figure 3. Evaluation Board Schematic

OUTLINE DIMENSIONS

Dimensions shown in inches and (mm).

20-Lead Thermally Enhanced Small Outline Package (PSOP)  
(RP-20)



C3003b-0-11/99