

Dual Micropower DC/DC Converters with Schottky Diodes

FEATURES

- Generates Well-Regulated Positive and Negative Outputs
- Low Quiescent Current:
20 μ A (per Converter) in Active Mode
<1 μ A in Shutdown Mode
- Internal 42V Power Switches
- Internal 42V Schottky Diodes
- Low V_{CESAT} Switch: 180mV at 150mA
- Input Voltage Range: 2.4V to 15V
- High Output Voltages: Up to \pm 40V
- Low Profile (0.8mm) 3mm x 3mm DFN Package

APPLICATIONS

- CCD Bias
- LCD Bias
- Handheld Computers
- Digital Cameras

DESCRIPTION

The LT[®]3463/LT3463A are dual micropower DC/DC converters with internal Schottky diodes in a 10-lead 3mm \times 3mm DFN package. Negative and positive LT3463 converters have a 250mA current limit. The LT3463A positive converter also has a 250mA limit, while the negative converter has a 400mA limit. Both devices have an input voltage range of 2.4V to 15V, making them ideal for a wide variety of applications. Each converter features a quiescent current of only 20 μ A, which drops to under 1 μ A in shutdown. A current limited, fixed off-time control scheme conserves operating current, resulting in high efficiency over a broad range of load current. The 42V switch enables high voltage outputs up to \pm 40V to be easily generated without the use of costly transformers. The low 300ns off-time permits the use of tiny, low profile inductors and capacitors to minimize footprint and cost in space-conscious portable applications.

 LTC and LT are registered trademarks of Linear Technology Corporation.

TYPICAL APPLICATION

CCD Bias Supply (15V, -8V)

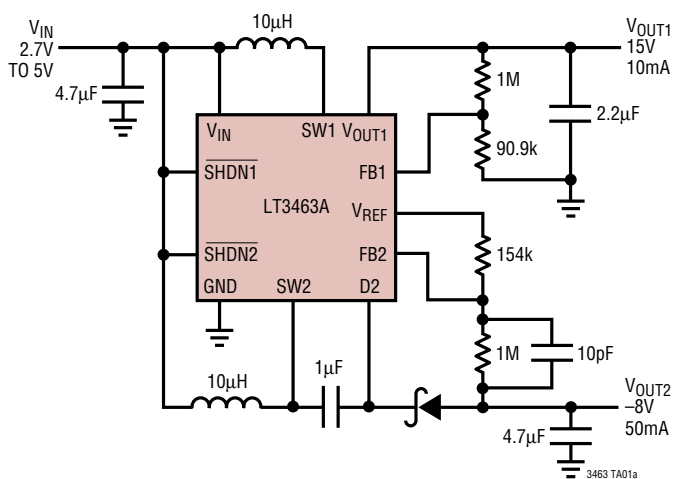

Efficiency and Power Loss

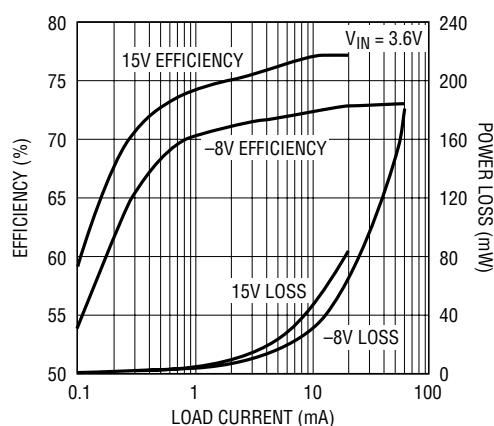

ABSOLUTE MAXIMUM RATINGS

(Note 1)

V_{IN} , $\overline{SHDN1}$, $\overline{SHDN2}$ Voltage	15V
SW1, SW2, V_{OUT1} Voltage	42V
D2 Voltage	-42V
FB1, FB2 Voltage Range	-0.3V to 2V
Junction Temperature	125°C
Operating Ambient Temperature Range	
(Note 2)	-40°C to 85°C
Storage Temperature Range	-65°C to 125°C

PACKAGE/ORDER INFORMATION

<p>DD PACKAGE 10-LEAD (3mm × 3mm) PLASTIC DFN $T_{JMAX} = 125^{\circ}\text{C}$, $\theta_{JA} = 43^{\circ}\text{C/W}$, $\theta_{JC} = 3^{\circ}\text{C/W}$ EXPOSED PAD (PIN 11) IS GND AND MUST BE SOLDERED TO PCB</p>	ORDER PART NUMBER
	LT3463EDD LT3463AEDD
	DD PART MARKING
	LAFK LBJK

Consult LTC Marketing for parts specified with wider operating temperature ranges.

ELECTRICAL CHARACTERISTICS

The ● denotes the specifications which apply over the full operating temperature range, otherwise specifications are at $T_A = 25^{\circ}\text{C}$. $V_{IN} = 2.5\text{V}$, $V_{\overline{SHDN}} = 2.5\text{V}$ unless otherwise noted.

PARAMETER	CONDITIONS	MIN	TYP	MAX	UNITS
Minimum Input Voltage			2.2	2.4	V
Total Quiescent Current	For Both Switchers, Not Switching		40	60	μA
Shutdown Current	$V_{\overline{SHDN1}} = V_{\overline{SHDN2}} = 0\text{V}$		0.1	1	μA
V_{REF} Pin Voltage	With 124k Ω to GND	● 1.23	1.25	1.27	V
V_{REF} Pin Voltage Line Regulation	With 124k Ω to GND		0.05	0.10	%/V
FB1 Comparator Trip Voltage	High to Low Transition	● 1.225	1.25	1.275	V
FB1 Comparator Hysteresis			8		mV
FB1 Line Regulation	$2.5\text{V} < V_{IN} < 15\text{V}$		0.05	0.10	%/V
FB1 Pin Bias Current (Note 3)	$V_{FB1} = 1.3\text{V}$	●	20	50	nA
FB2 Comparator Trip Voltage	Low to High Transition	● 0	3	12	mV
FB2 Comparator Hysteresis			8		mV
FB2 Line Regulation ($V_{REF} - V_{FB2}$)	$2.5\text{V} < V_{IN} < 15\text{V}$		0.05	0.10	%/V
FB2 Pin Bias Current (Note 4)	$V_{FB2} = -0.1\text{V}$	●	20	50	nA
SW1 Switch Off Time	$V_{OUT1} - V_{IN} = 4\text{V}$ $V_{OUT1} - V_{IN} = 0\text{V}$		300 1.5		ns μs
SW2 Switch Off Time	$V_{FB2} < 0.1\text{V}$ $V_{FB2} = 1\text{V}$		300 1.5		ns μs
Switch V_{CESAT} (SW1, SW2)	$I_{SW} = 150\text{mA}$		180		mV
Switch Current Limit (SW1)		180	250	320	mA
Switch Current Limit (SW2)	LT3463 LT3463A	180 320	250 400	320 460	mA mA
Switch Leakage Current (SW1, SW2)	Switch Off, $V_{SW} = 42\text{V}$		0.01	1	μA
Schottky Forward Voltage (V_{OUT1} , D2)	$I_D = 150\text{mA}$		750		mV
Schottky Reverse Leakage Current	$V_{OUT1} - V_{SW} = 42\text{V}$ $V_{D2} = -42\text{V}$		1 1	5 5	μA μA
$\overline{SHDN1}$ Pin Current	$V_{\overline{SHDN1}} = 2.5\text{V}$		4	10	μA
$\overline{SHDN2}$ Pin Current	$V_{\overline{SHDN2}} = 2.5\text{V}$		4	10	μA
$\overline{SHDN1}/\overline{SHDN2}$ Start-Up Threshold		0.3	1	1.5	V

Note 1: Absolute Maximum Ratings are those values beyond which the life of a device may be impaired.

Note 2: The LT3463/LT3463A are guaranteed to meet performance specifications from 0°C to 70°C. Specifications over the -40°C to 85°C

operating ambient temperature range are assured by design, characterization and correlation with statistical process controls.

Note 3: Bias current flows into the FB1 pin.

Note 4: Bias current flows out of the FB2 pin.

TYPICAL PERFORMANCE CHARACTERISTICS

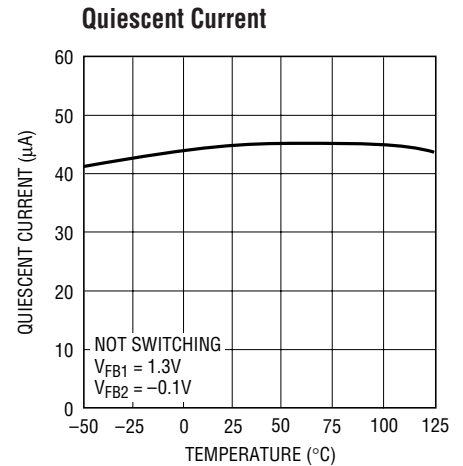
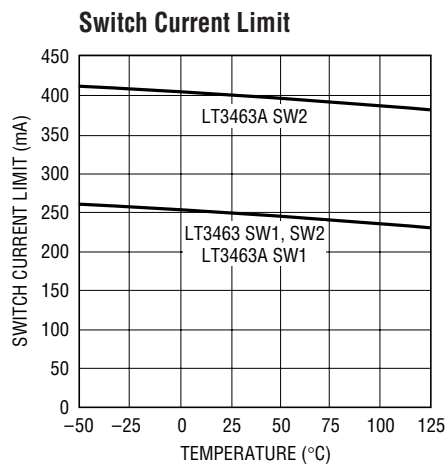
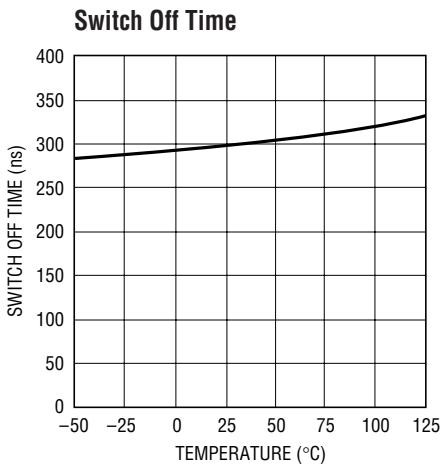
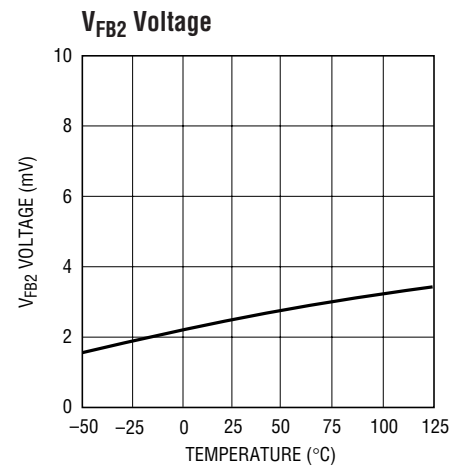
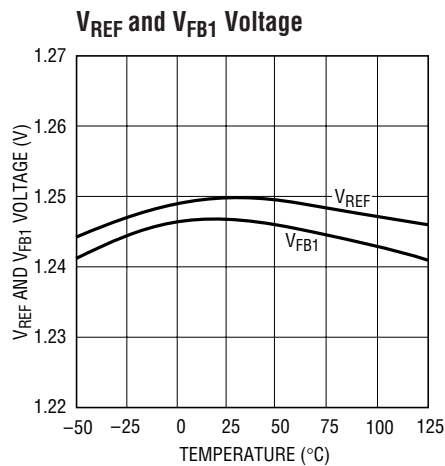
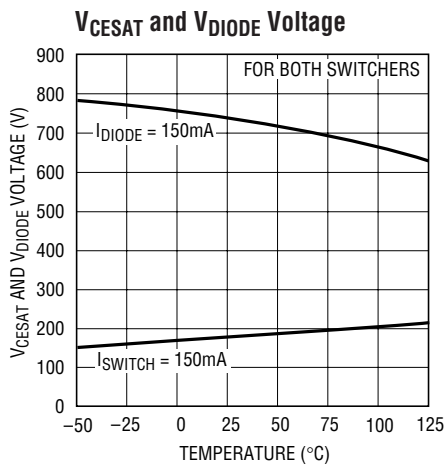

PIN FUNCTIONS

V_{OUT1} (Pin 1): Output Voltage Switcher 1. This is the cathode of an internal Schottky diode whose anode is connected to the SW1 pin.

SW1 (Pin 2): Switch Pin for Switcher 1. This is the collector of the internal NPN switch. Minimize the metal trace area connected to this pin to minimize EMI.

V_{IN} (Pin 3): Input Supply Pin. Bypass this pin with a capacitor as close to the device as possible.

SW2 (Pin 4): Switch Pin for Switcher 2. This is the collector of the internal NPN switch. Minimize the metal trace area connected to this pin to minimize EMI.

D2 (Pin 5): Diode for Switcher 2. This is the anode of an internal Schottky diode whose cathode connected to the GND pin.

FB2 (Pin 6): Feedback Pin for Switcher 2. Set the output voltage by selecting values for R3 and R4.

V_{REF} (Pin 7): Voltage Reference Pin (1.25V). This pin is used along with FB2 to set the negative output voltage for Switcher 2.

SHDN2 (Pin 8): Shutdown Pin for Switcher 2. Pull this pin above 1.5V to enable Switcher 2. Pull below 0.3V to turn it off. Do not leave this pin floating.

PIN FUNCTIONS

SHDN1 (Pin 9): Shutdown Pin for Switcher 1. Pull this pin above 1.5V to enable Switcher 1. Pull below 0.3V to turn it off. Do not leave this pin floating.

FB1 (Pin 10): Feedback Pin for Switcher 1. Set the output voltage by selecting values for R1 and R2.

GND (Pin 11): Exposed Pad. Solder this exposed pad directly to the local ground plane. This pad must be electrically connected for proper operation.

BLOCK DIAGRAM

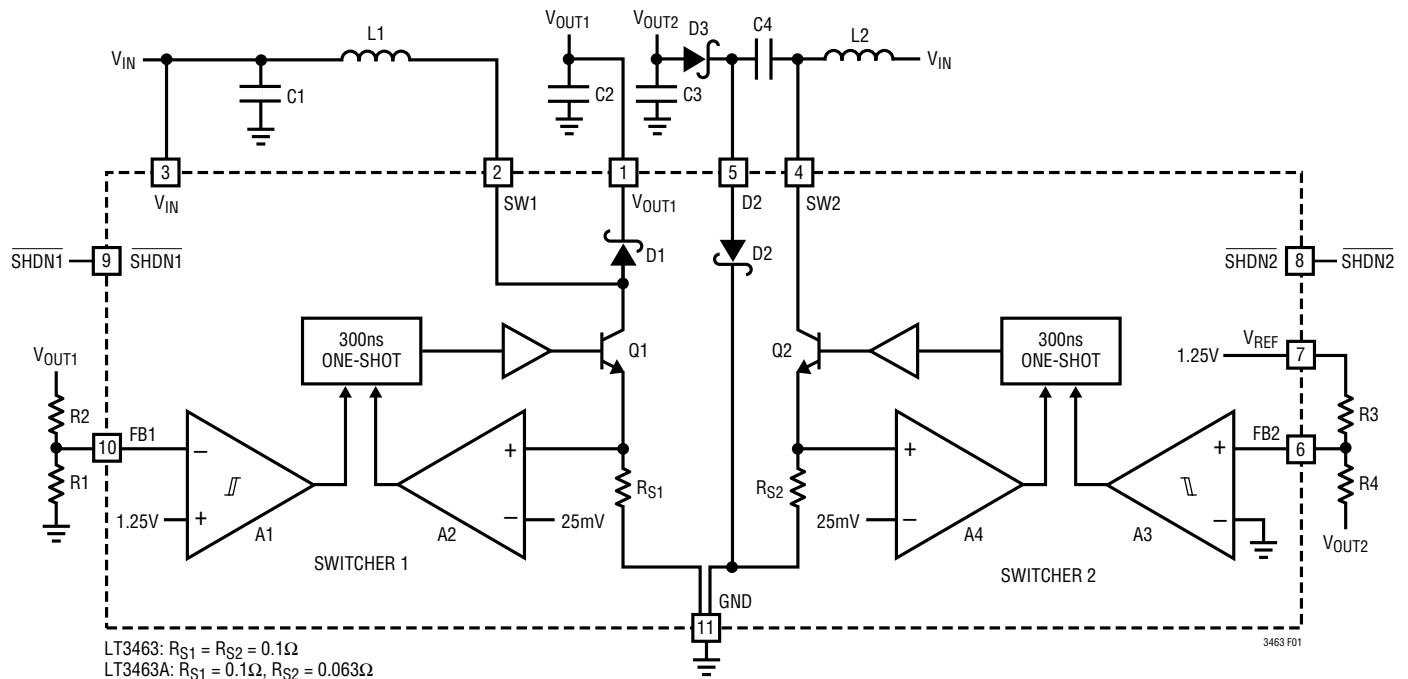

Figure 1. Block Diagram

OPERATION

The LT3463 uses a constant off-time control scheme to provide high efficiency over a wide range of output current. Operation can be best understood by referring to the block diagram in Figure 1. When the voltage at the FB1 pin is slightly above 1.25V, comparator A1 disables most of the internal circuitry. Output current is then provided by capacitor C2, which slowly discharges until the voltage at the FB1 pin goes below the hysteresis point of A1 (typical hysteresis at the FB1 pin is 8mV). A1 then enables the internal circuitry, turns on power switch Q1, and the

current in inductor L1 begins ramping up. Once the switch current reaches 250mA, comparator A2 resets the one-shot, which turns off Q1 for 300ns. Q1 turns on again and the inductor currents ramp back up to 250mA, then A2 again resets the one-shot. This switching action continues until the output voltage is charged up (until the FB1 pin reaches 1.25V), then A1 turns off the internal circuitry and the cycle repeats. The second switching regulator is an inverting converter (which generates a negative output) but the basic operation is the same.

APPLICATIONS INFORMATION

Choosing an Inductor

Several recommended inductors that work well with the LT3463 are listed in Table 1, although there are many other manufacturers and devices that can be used. Consult each manufacturer for more detailed information and for their entire selection of related parts. Many different sizes and shapes are available. Use the equations and recommendations in the next few sections to find the correct inductance value for your design.

Table 1. Recommended Inductors

PART	L (μH)	MAX I _{DC} (mA)	MAX DCR(Ω)	HEIGHT (mm)	MANUFACTURER
CMD4D06	4.7	750	0.22	0.8	Sumida (847) 956-0666 www.sumida.com
	10	500	0.46		
	22	310	1.07		
CDRH3D16	10	500	0.19	1.8	Sumida
	22	310	0.36		
LPO4812	4.7	600	0.16	1.2	Coilcraft (847) 639-6400 www.coilcraft.com
	10	400	0.30		
	22	280	0.64		
LQH32C	10	450	0.39	1.8	Murata (714) 852-2001 www.murata.com
	15	300	0.75		
	22	250	0.92		
LQH31C	4.7	340	0.85	1.8	Murata

Inductor Selection—Boost Regulator

The formula below calculates the appropriate inductor value to be used for a boost regulator using the LT3463 (or at least provides a good starting point). This value provides a good tradeoff in inductor size and system performance. Pick a standard inductor close to this value. A larger value can be used to slightly increase the available output current, but limit it to around twice the value calculated below, as too large of an inductance will increase the output voltage ripple without providing much additional output current. A smaller value can be used (especially for systems with output voltages greater than 12V) to give a smaller physical size. Inductance can be calculated as:

$$L = \frac{V_{OUT} - V_{IN(MIN)} + V_D}{I_{LIM}} t_{OFF}$$

where $V_D = 0.5V$ (Schottky diode voltage), $I_{LIM} = 250mA$ (or 400mA) and $t_{OFF} = 300ns$; for designs with varying V_{IN}

such as battery powered applications, use the minimum V_{IN} value in the above equation. For most regulators with output voltages below 7V, a 4.7μH inductor is the best choice, even though the equation above might specify a smaller value.

For higher output voltages, the formula above will give large inductance values. For a 3V to 20V converter (typical LCD Bias application), a 21μH inductor is called for with the above equation, but a 10μH inductor could be used without much reduction in the maximum output current.

Inductor Selection—Inverting Regulator

The formula below calculates the appropriate inductor value to be used for an inverting regulator using the LT3463 (or at least provides a good starting point). This value provides a good tradeoff in inductor size and system performance. Pick a standard inductor close to this value (both inductors should be the same value). A larger value can be used to slightly increase the available output current, but limit it to around twice the value calculated below, as too large of an inductance will increase the output voltage ripple without providing much additional output current. A smaller value can be used (especially for systems with output voltages greater than 12V) to give a smaller physical size. Inductance can be calculated as:

$$L = 2 \left(\frac{|V_{OUT}| + V_D}{I_{LIM}} \right) t_{OFF}$$

where $V_D = 0.5V$ (Schottky diode voltage), $I_{LIM} = 250mA$ (or 400mA) and $t_{OFF} = 300ns$.

For higher output voltages, the formula above will give large inductance values. For a 3V to 20V converter (typical LCD bias application), a 49μH inductor is called for with the above equation, but a 10μH or 22μH inductor could be used without much reduction in the maximum output current.

Inductor Selection—Inverting Charge Pump Regulator

For the inverting regulator, the voltage seen by the internal power switch is equal to the sum of the absolute value of the input and output voltages, so that generating high

APPLICATIONS INFORMATION

output voltages from a high input voltage source will often exceed the 50V maximum switch rating. For instance, a 12V to –40V converter using the inverting topology would generate 52V on the SW pin, exceeding its maximum rating. For this application, an inverting charge pump is the best topology.

The formula below calculates the approximate inductor value to be used for an inverting charge pump regulator using the LT3463. As for the boost inductor selection, a larger or smaller value can be used. For designs with varying V_{IN} such as battery powered applications, use the minimum V_{IN} value in the equation below.

$$L = \frac{|V_{OUT}| - V_{IN(MIN)} + V_D}{I_{LIM}} t_{OFF}$$

Capacitor Selection

The small size and low ESR of ceramic capacitors makes them ideal for LT3463 applications. Use only X5R and X7R types because they retain their capacitance over wider voltage and temperature ranges than other ceramic types. A 1 μ F input capacitor and a 0.22 μ F or 0.47 μ F output capacitor are sufficient for most applications. Table 2 shows a list of several ceramic capacitor manufacturers. Consult the manufacturers for more detailed information on their entire selection of ceramic capacitors. For applications needing very low output voltage ripple, larger output capacitor values can be used.

Table 2. Recommended Ceramic Capacitor Manufacturers

MANUFACTURER	PHONE	URL
AVX	843-448-9411	www.avxcorp.com
Kemet	408-986-0424	www.kemet.com
Murata	814-237-1431	www.murata.com
Taiyo Yuden	408-573-4150	www.t-yuden.com

Inrush Current

When V_{IN} is increased from ground to operating voltage while the output capacitor is discharged, an inrush current will flow through the inductor and integrated Schottky diode into the output capacitor. Conditions that increase

inrush current include a larger more abrupt voltage step at V_{IN} , a larger output capacitor tied to the outputs, and an inductor with a low saturation current.

While the internal diode is designed to handle such events, the inrush current should not be allowed to exceed 1 amp. For circuits that use output capacitor values within the recommended range and have input voltages of less than 5V, inrush current remains low, posing no hazard to the device. In cases where there are large steps at V_{IN} and/or a large capacitor is used at the outputs, inrush current should be measured to ensure safe operation.

Setting the Output Voltages

The output voltages are programmed using two feedback resistors. As shown in Figure 1, resistors R1 and R2 program the positive output voltage (for Switcher 1), and resistors R3 and R4 program the negative output voltage (for Switcher 2) according to the following formulas:

$$V_{OUT1} = 1.25V \left(1 + \frac{R2}{R1} \right)$$

$$V_{OUT2} = -1.25V \left(\frac{R4}{R3} \right)$$

R1 and R3 are typically 1% resistors with values in the range of 50k to 250k.

Board Layout Considerations

As with all switching regulators, careful attention must be paid to the PCB board layout and component placement. To maximize efficiency, switch rise and fall times are made as short as possible. To prevent electromagnetic interference (EMI) problems, proper layout of the high frequency switching path is essential. The voltage signal of the SW pin has sharp rising and falling edges. Minimize the length and area of all traces connected to the SW pin and always use a ground plane under the switching regulator to minimize interplane coupling. In addition, the ground connection for the feedback resistor R1 should be tied directly to the GND pin and not shared with any other component, ensuring a clean, noise-free connection.

TYPICAL APPLICATION

Dual Output ±20V Converter

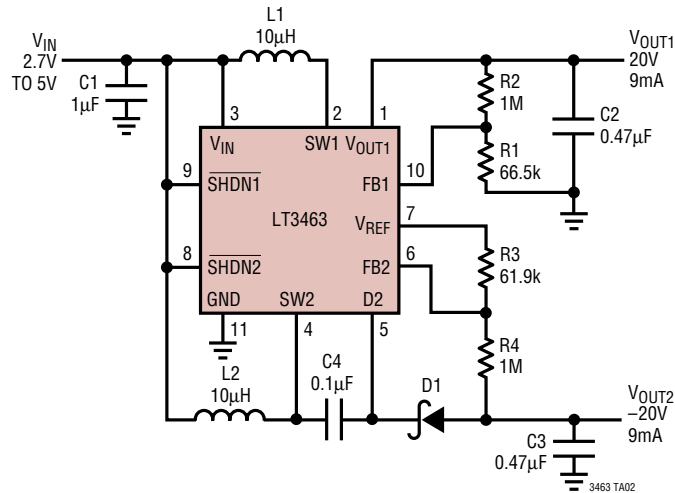

PACKAGE DESCRIPTION

DD Package
10-Lead Plastic DFN (3mm × 3mm)
 (Reference LTC DWG # 05-08-1699)

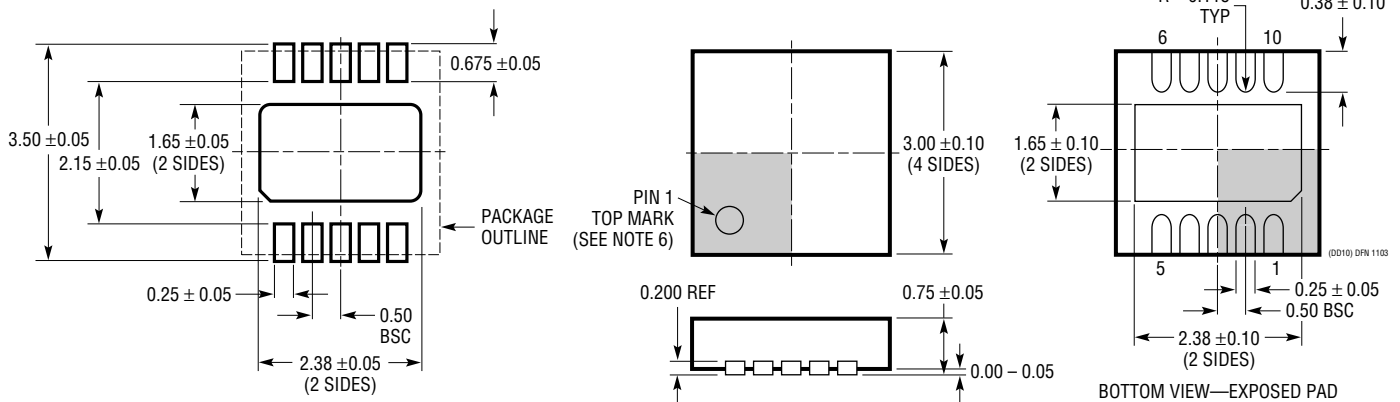

RECOMMENDED SOLDER PAD PITCH AND DIMENSIONS

NOTE:

1. DRAWING TO BE MADE A JEDEC PACKAGE OUTLINE MO-229 VARIATION OF (WEED-2). CHECK THE LTC WEBSITE DATA SHEET FOR CURRENT STATUS OF VARIATION ASSIGNMENT
2. DRAWING NOT TO SCALE
3. ALL DIMENSIONS ARE IN MILLIMETERS
4. DIMENSIONS OF EXPOSED PAD ON BOTTOM OF PACKAGE DO NOT INCLUDE MOLD FLASH. MOLD FLASH, IF PRESENT, SHALL NOT EXCEED 0.15mm ON ANY SIDE

5. EXPOSED PAD SHALL BE SOLDER PLATED
6. SHADED AREA IS ONLY A REFERENCE FOR PIN 1 LOCATION ON THE TOP AND BOTTOM OF PACKAGE

TYPICAL APPLICATION

CCD Bias Supply

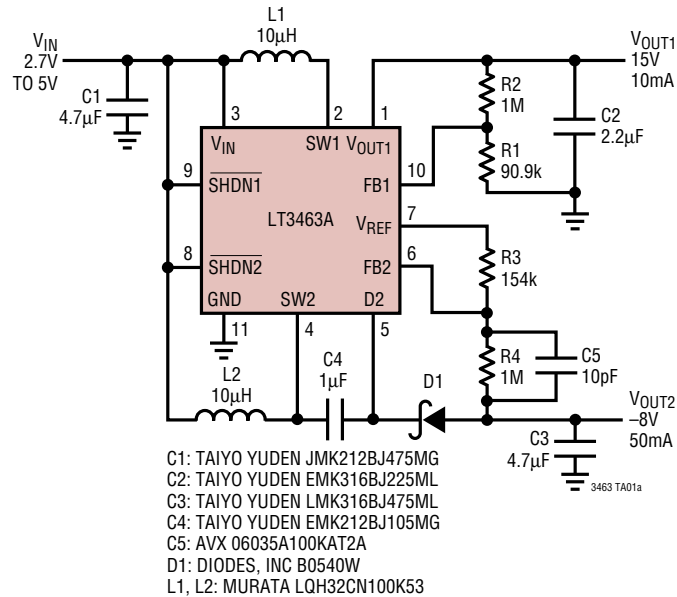

Typical Waveforms for 15V Output

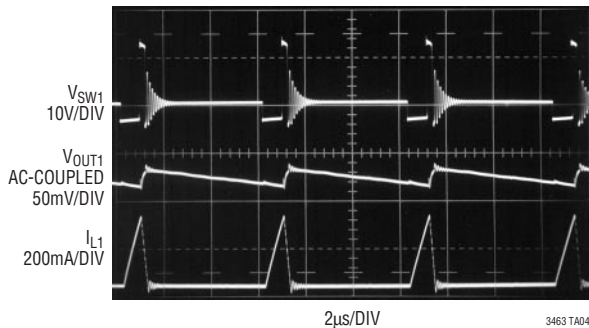

Typical Waveforms for -8V Output

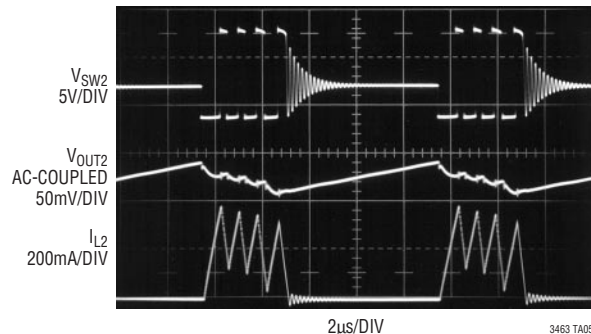

RELATED PARTS

PART NUMBER	DESCRIPTION	COMMENTS
LT1615/LT1615-1	300mA/80mA (I_{SW}), High Efficiency Step-Up DC/DC Converters	V_{IN} : 1V to 15V, $V_{OUT(MAX)}$: 34V, I_Q : 20µA, I_{SD} : <1µA, ThinSOT Package
LT1944	Dual Output 350mA (I_{SW}), Constant Off-Time, High Efficiency Step-Up DC/DC Converter	V_{IN} : 1.2V to 15V, $V_{OUT(MAX)}$: 34V, I_Q : 20µA, I_{SD} : <1µA, MS Package
LT1944-1	Dual Output 150mA (I_{SW}), Constant Off-Time, High Efficiency Step-Up DC/DC Converter	V_{IN} : 1.2V to 15V, $V_{OUT(MAX)}$: 34V, I_Q : 20µA, I_{SD} : <1µA, MS Package
LT1945	Dual Output, Pos/Neg, 350mA (I_{SW}), Constant Off-Time, High Efficiency Step-Up DC/DC Converter	V_{IN} : 1.2V to 15V, $V_{OUT(MAX)}$: ±34V, I_Q : 20µA, I_{SD} : <1µA, MS Package
LT3464	85mA (I_{SW}), High Efficiency Step-Up DC/DC Converter with Integrated Schottky and PNP Disconnect	V_{IN} : 2.3V to 10V, $V_{OUT(MAX)}$: 34V, I_Q : 25µA, I_{SD} : <1µA, ThinSOT Package