

**User Guide for
FEBFAN23XX_LVA
Evaluation Board**

High-Efficiency Synchronous Buck Converters

Featured Products:

FAN2306/56/SV06/SV56/06M/SV06P

FAN2310/60/SV10M/SV60

FAN2315/65/SV15M/SV65

*Direct questions or comments
about this evaluation board to:
“Worldwide Direct Support”*

Fairchild Semiconductor.com

Table of Contents

1. Introduction	3
1.1. Typical Applications	3
1.2. Features	3
2. Featured Products	4
3. Product Specifications	5
4. Board Specifications.....	5
5. Schematic	6
6. Test Setup.....	7
6.1. Test Equipment.....	7
6.2. Test Setup.....	7
7. Configuration Changes.....	8
7.1. Enable Selection.....	8
7.2. PGOOD	8
7.3. On-Board Transient Generator.....	8
8. Test Procedure	9
8.1. Measurement Procedure	9
9. Performance Data and Characteristic Curves.....	10
10. Printed Circuit Board.....	11
11. Bill of Materials.....	13
12. Revision History.....	18

This user guide supports the evaluation board for the FAN23XX / FAN23SVXX family of integrated synchronous buck regulators. It should be used in conjunction with the product datasheets as well as Fairchild's application notes and technical support team. Please visit Fairchild's website at www.fairchildsemi.com.

1. Introduction

The FAN23XX evaluation board highlights the FAN23XX family of highly efficient integrated synchronous buck regulators. This family of devices combines Fairchild's constant on-time control architecture with integrated MOSFETs to supply a wide range of load current in various applications.

1.1. Typical Applications

- Servers
- NVDC Notebooks
- Telecommunications
- Game Consoles
- Storage

1.2. Features

- Component Footprints to Cover Load Currents: 6 A to 15 A
- Configurable Enable Function
- Supports Startup with Output Pre-bias
- On-board Transient Generator with Adjustable Load Current Slew Rate
- Supports Internal Regulator ("SV" parts) or External Bias Supply
- Test Points for Probing Critical Waveforms and Efficiency Measurements

2. Featured Products

Table 1. Featured Product Descriptions

Current Rating	Part Number	Board Number	Description
6 A	FAN2306	FEBFAN2306_LVA	6 A Integrated Synchronous Buck Regulator with Ultrasonic Mode
	FAN2356	FEBFAN2356_LVA	6 A Integrated Synchronous Buck Regulator with Ultrasonic Mode and Wide Input Range
	FAN23SV06	FEBFAN23SV06_LVA	6 A Integrated Synchronous Buck Regulator with Ultrasonic Mode and Internal Linear Regulator
	FAN23SV56	FEBFAN23SV56_LVA	6 A Integrated Synchronous Buck Regulator with Ultrasonic Mode, Internal Linear Regulator and Wide Input Range
	FAN2306M	FEBFAN2306M_LVA	6 A Integrated Synchronous Buck Regulator with No Ultrasonic Mode
	FAN23SV06P	FEBFAN23SV06P_LVA	6 A Integrated Synchronous Buck Regulator with Internal Linear Regulator and No PFM Mode
10 A	FAN2310	FEBFAN2310_LVA	10 A Integrated Synchronous Buck Regulator with Ultrasonic Mode
	FAN2360	FEBFAN2360_LVA	10 A Integrated Synchronous Buck Regulator with Ultrasonic Mode and Wide Input Range
	FAN23SV60	FEBFAN23SV60_LVA	10 A Integrated Synchronous Buck Regulator with Ultrasonic Mode, Internal Linear Regulator and Wide Input Range
	FAN23SV10M	FEBFAN23SV10M_LVA	10 A Integrated Synchronous Buck Regulator with Internal Linear Regulator and No Ultrasonic Mode
15 A	FAN2315	FEBFAN2315_LVA	15 A Integrated Synchronous Buck Regulator with Ultrasonic Mode
	FAN2365	FEBFAN2365_LVA	15 A Integrated Synchronous Buck Regulator with Ultrasonic Mode and Wide Input Range
	FAN23SV65	FEBFAN23SV65_LVA	15 A Integrated Synchronous Buck Regulator with Ultrasonic Mode, Internal Linear Regulator and Wide Input Range
	FAN23SV15M	FEBFAN23SV15M_LVA	15 A Integrated Synchronous Buck Regulator with Internal Linear Regulator and No Ultrasonic Mode

3. Product Specifications

Table 2. Product Specifications

Current Rating	Part Number	EVB Number	V _{IN} Range (V)	V _{OUT} Range (V)	f _{sw} Range (kHz)	Internal LDO	PFM Enable	Ultrasonic Mode
6 A	FAN2306	FEBFAN2306_LVA	4.5-15	0.6~5.5	200~1500	No	Yes	Yes
	FAN2356	FEBFAN2356_LVA	4.5-24	0.6~5.5	200~1500	No	Yes	Yes
	FAN23SV06	FEBFAN23SV06_LVA	7-15	0.6~5.5	200~1500	Yes	Yes	Yes
	FAN23SV56	FEBFAN23SV56_LVA	7-24	0.6~5.5	200~1500	Yes	Yes	Yes
	FAN2306M	FEBFAN2306M_LVA	4.5-15	0.6~5.5	200~1500	No	Yes	No
	FAN23SV06P	FEBFAN23SV06P_LVA	7-15	0.6~5.5	200~1500	Yes	No	Yes
10 A	FAN2310	FEBFAN2310_LVA	4.5-15	0.6~5.5	200~1500	No	Yes	Yes
	FAN2360	FEBFAN2360_LVA	4.5-24	0.6~5.5	200~1500	No	Yes	Yes
	FAN23SV60	FEBFAN23SV60_LVA	7-24	0.6~5.5	200~1500	Yes	Yes	Yes
	FAN23SV10M	FEBFAN23SV10M_LVA	7-15	0.6~5.5	200~1500	Yes	Yes	No
15 A	FAN2315	FEBFAN2315_LVA	4.5-15	0.6~5.5	200~1000	No	Yes	Yes
	FAN2365	FEBFAN2365_LVA	4.5-24	0.6~5.5	200~1000	No	Yes	Yes
	FAN23SV65	FEBFAN23SV65_LVA	7-24	0.6~5.5	200~1000	Yes	Yes	Yes
	FAN23SV15M	FEBFAN23SV15M_LVA	7-15	0.6~5.5	200~1000	Yes	Yes	No

4. Evaluation Board Specifications

Table 3. Evaluation Board Configurations & PCB Structure

Description	Symbol	Value	Comments
Input Supply	PVIN/VIN		Refer to Table 2
Bias Supply for Controller	PVCC/VCC	5 V	Required only for Non-LDO devices
Output Voltage	V _{OUT}	1.2 V	
Switching Frequency	f _{sw}	500 kHz	
Output Load Current	I _{OUT}		Refer to Table 2
Output Current Limit		120%	Maximum load current
PCB Size		7 cm X 7 cm	
PCB Layer		4 Layers	
PCB Thickness		1.6 mm	
PCB Copper Thickness		1 oz-1 oz-1 oz-1 oz	

5. Schematics

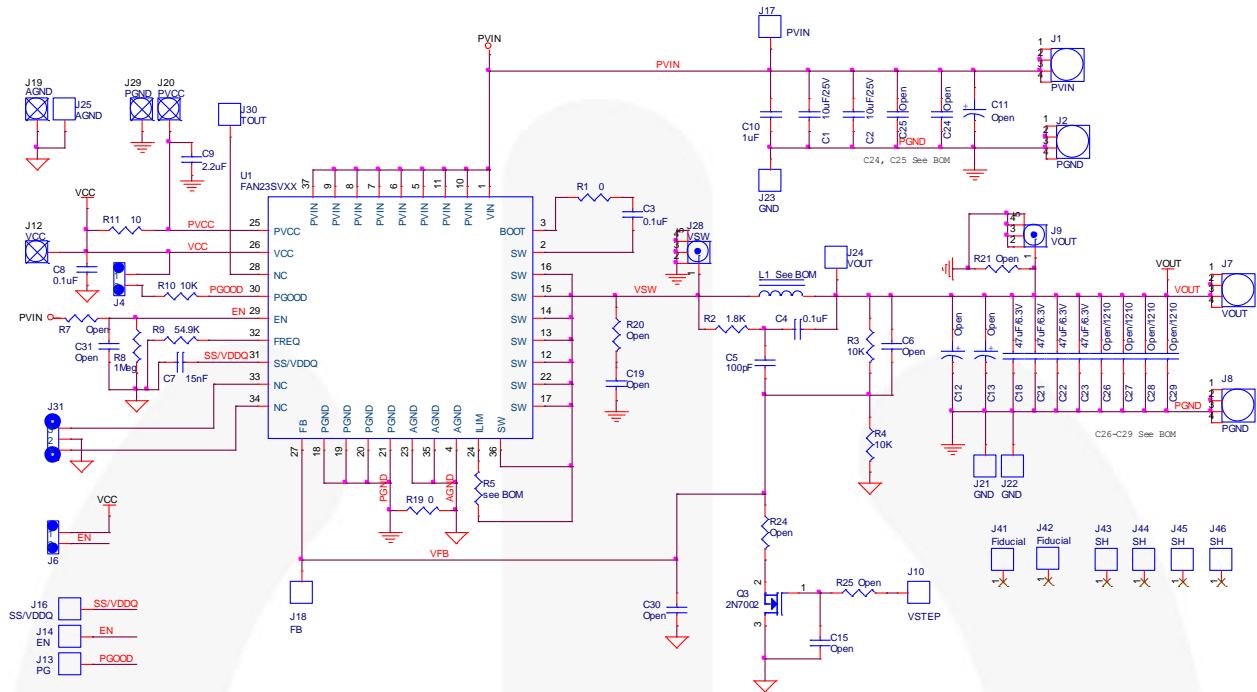

Figure 1. Evaluation Board Regulator Schematic

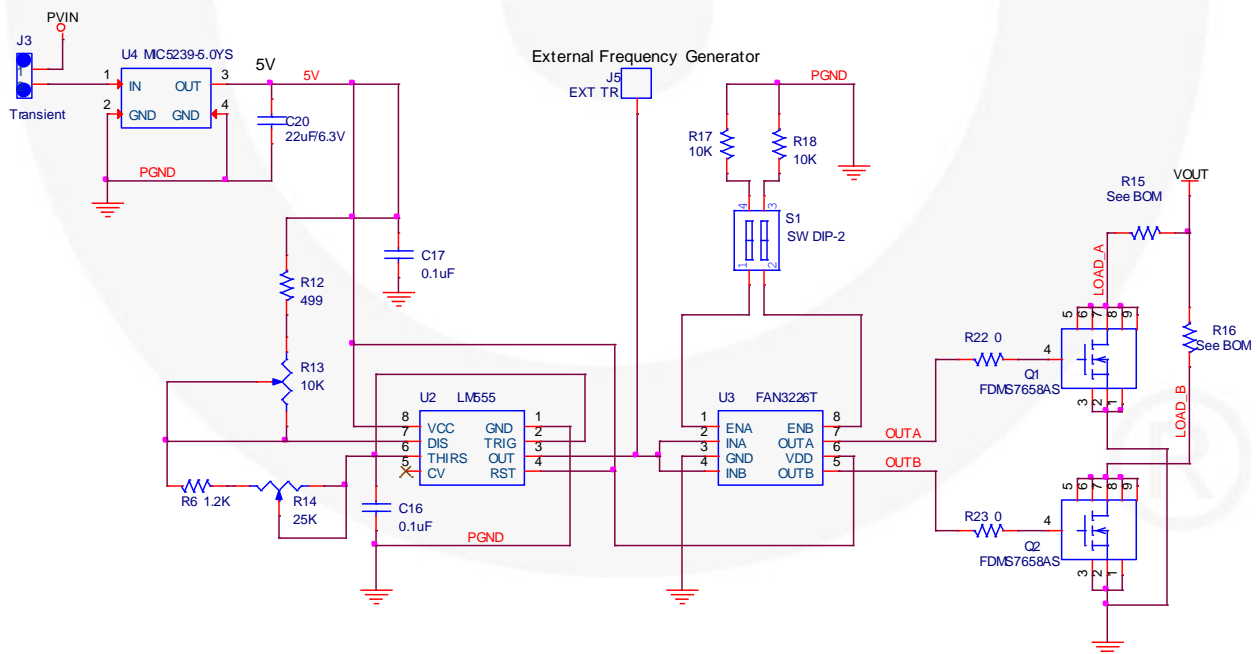

Figure 2. Evaluation Board Transient Generator Schematic

6. Test Setup

6.1. Test Equipment

- 0 - 20 V / 5 A power supply for input voltage
- 0 - 5 V / 0.5 A power supply for optional PVCC bias (when using non-SV parts)
- Oscilloscope to view waveforms
- 0 - 5 V / 0.1 A power supply for optional external enable signal

6.2. Test Setup

- Adjust V_{IN} power supply, PVCC bias supply, and external EN supply to 0 V; connect as shown in Figure 3 (non-SV part) or Figure 4 (SV part).
- Connect V_{IN} supply to PV_{IN} (J1) and GND (J2).
- For non-SV parts, connect V_{BIAS} supply to PVCC (J20) and PGND (J29).
- Connect the external enable source to EN (J14) and AGND (J25).

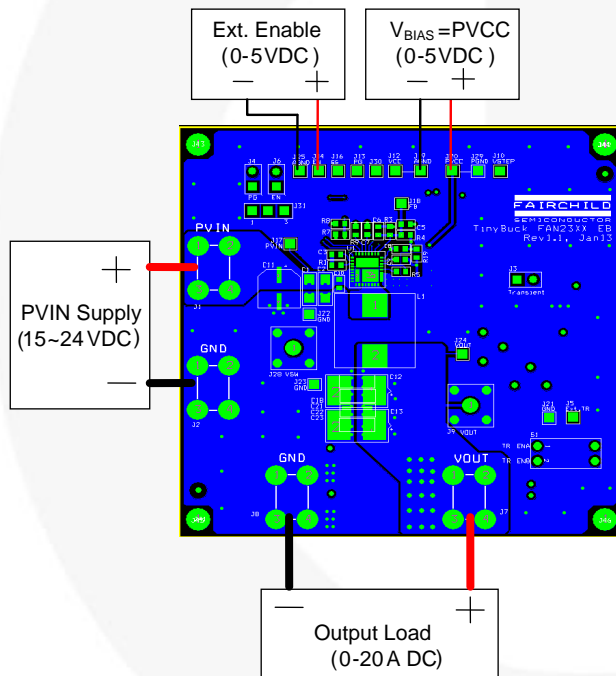

Figure 3. Test Setup for Non-SV Application
(V_{BIAS} Required)

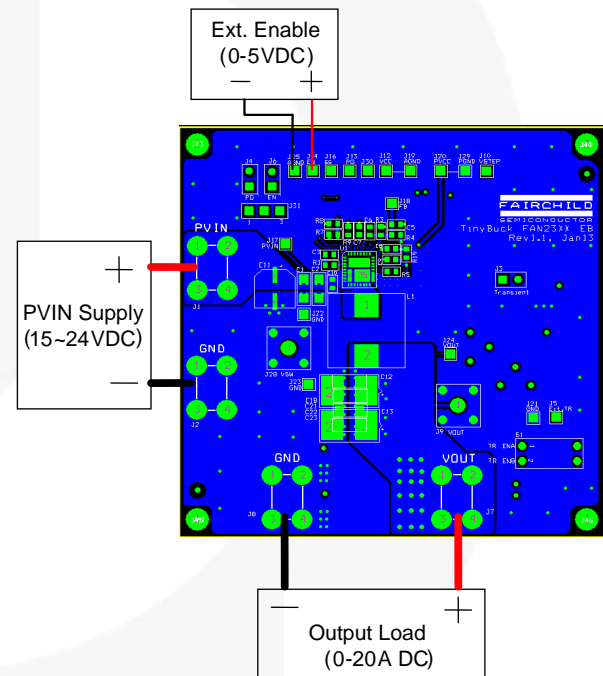

Figure 4. Test Setup for SV (Single Voltage)
Applications

7. Configuration Changes

7.1. Enable Selection

The FAN23XX evaluation board can be enabled using an external-enable-logic signal, as shown in Figure 3 and Figure 4. By default, R8 is populated with 1 M Ω to hold EN LOW. For non-SV parts, an auto-enable function can be implemented by placing a shorting jumper in location J6 to enable the part when PVCC is applied.

7.2. PGOOD

Jumper J4 is normally populated with a shorting jumper to allow the PGOOD pin to pull HIGH to V_{CC}. For efficiency measurements under extremely light loads, the shorting jumper should be removed for accurate efficiency measurements.

7.3. On-Board Transient Generator

Transient generator circuitry, shown in Figure 2, is included on the bottom of the board to facilitate testing of extremely fast transient loads, with the following usage guidelines:

- A shorting jumper installed on J3 enables the transient generator.
- Open J3 to conduct efficiency testing.
- R13 and R14 adjust the frequency and duty cycle of the LM555 timer.
- J5 can be used to monitor transient frequency and to trigger an oscilloscope.
- Switch S1 enables turn-on of load switch Q1 or Q2 or both simultaneously.
- Load applied with Q1 is equal to V_{OUT}/R15; with Q2 equal to V_{OUT}/R16.
- Use a low duty cycle to minimize power dissipation on PCB.
- R22/R23 can be increased in value to reduce load current slew rate.

8. Test Procedure

8.1. Measurement Procedure

- Set up equipment and board as shown in Figure 3 or Figure 4.
- For efficiency testing, open J3 (disable transient generator) and J4 (open PGOOD).
- Adjust load to sink 0 A.
- Monitor V_{IN} on J17(+) and J23(-) as voltage is increased from 0 V to 12 V.
- Adjust the external enable signal to 3.3 V to enable converter operation.
- Monitor PVCC on J20(+) and J19(-) as voltage is increased from 0 to 5 V.
- Monitor V_{OUT} on J24(+) and J23(-).
- With I_{OUT} from 0 to $I_{OUT,MAX}$, V_{OUT} should remain in regulation.
- To disable the converter, adjust the external enable signal to 0 V.
- After the converter is disabled, reduce PVCC to 0 V; then reduce V_{IN} to 0 V.

Table 4. List of Test Points and Connections

Test Points	Name	Description
J1	PVIN	V_{IN} connection (+)
J2	GND	V_{IN} connection (-)
J3	Transient	Connects PVIN to power transient generator
J4	PG	Connects PGOOD open-drain to pull-up resistor
J5	Ext. TR	External transient generator frequency monitor
J6	EN	Connects EN to VCC for auto-enable with non-SV parts
J7	VOUT	V_{OUT} connection (+)
J8	GND	V_{OUT} connection (-)
J9	VOUT	V_{OUT} scope jack
J10	VSTEP	Input to optional V_{OUT} step circuit
J12	VCC	Monitor V_{CC} voltage
J13	PG	PGOOD output
J14	EN	Enable input to controller
J16	SS	Monitor SS pin
J17	PVIN	Input voltage (+)
J18	FB	Feedback pin 27
J19	AGND	
J20	PVCC	PVCC supply input (+)
J21	GND	
J22	GND	Input voltage (-)
J23	GND	V_{OUT} monitor (-)
J24	VOUT	V_{OUT} monitor (+)
J25	AGND	AGND reference for EN input
J28	VSW	Switch node scope jack
J29	PGND	PVCC supply input (-)
J30		No connect
J31		No connect

9. Performance Data and Characteristic Curves

Additional typical operational and efficiency curves are included in the individual datasheets for the family of parts.

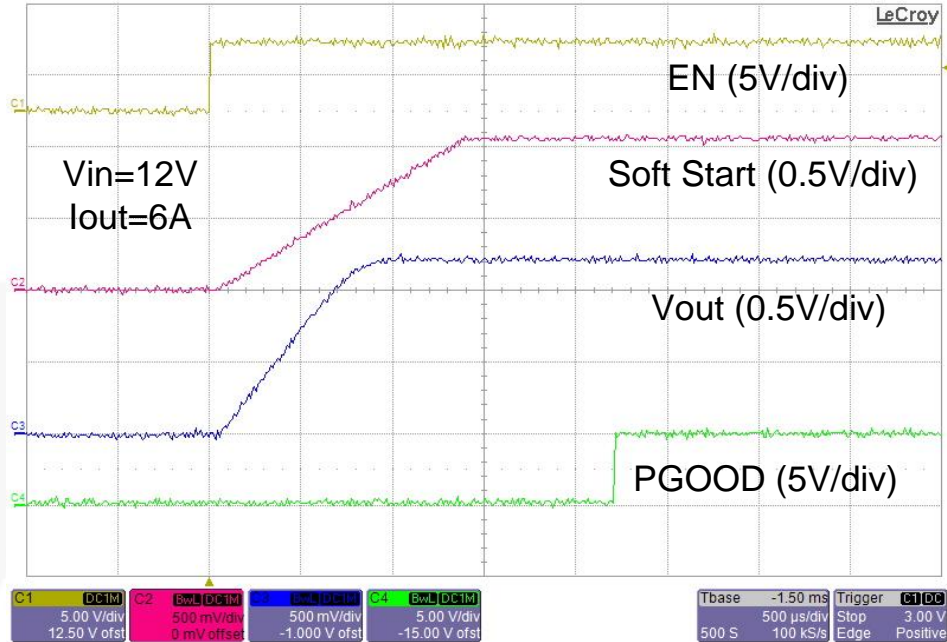

Figure 5. Typical FAN2306 Startup Waveforms

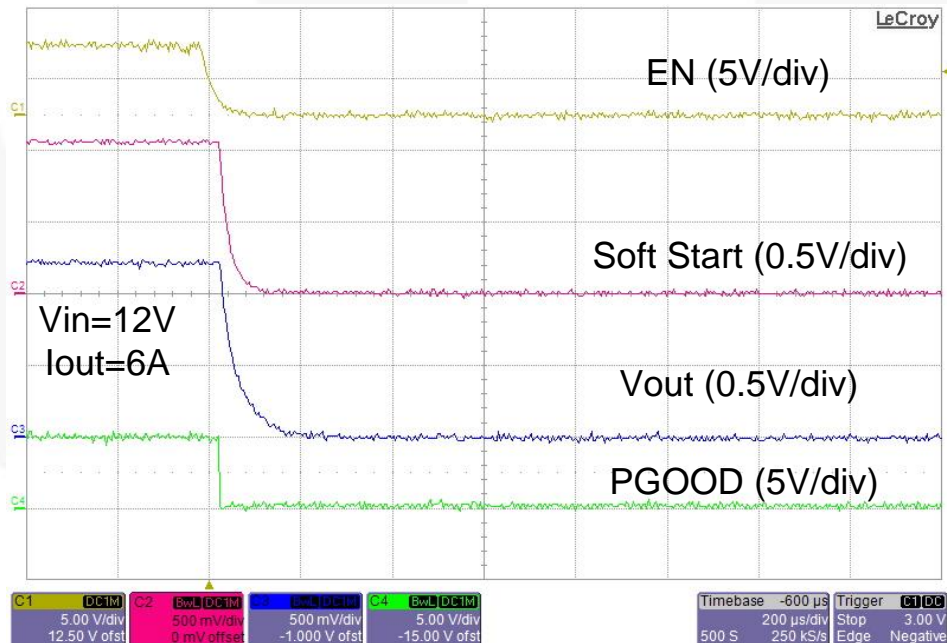

Figure 6. Typical FAN2306 Shutdown Waveforms

10. Printed Circuit Board

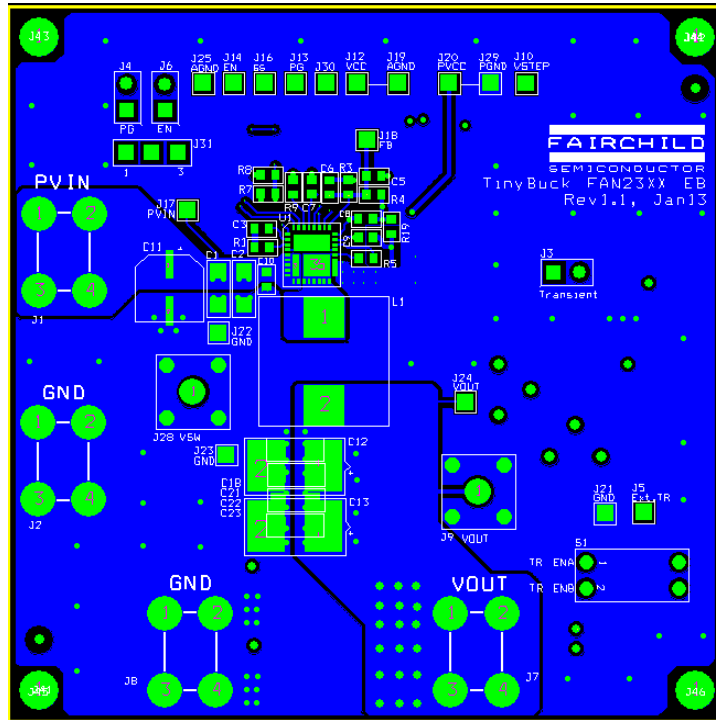

Figure 7. Top Side

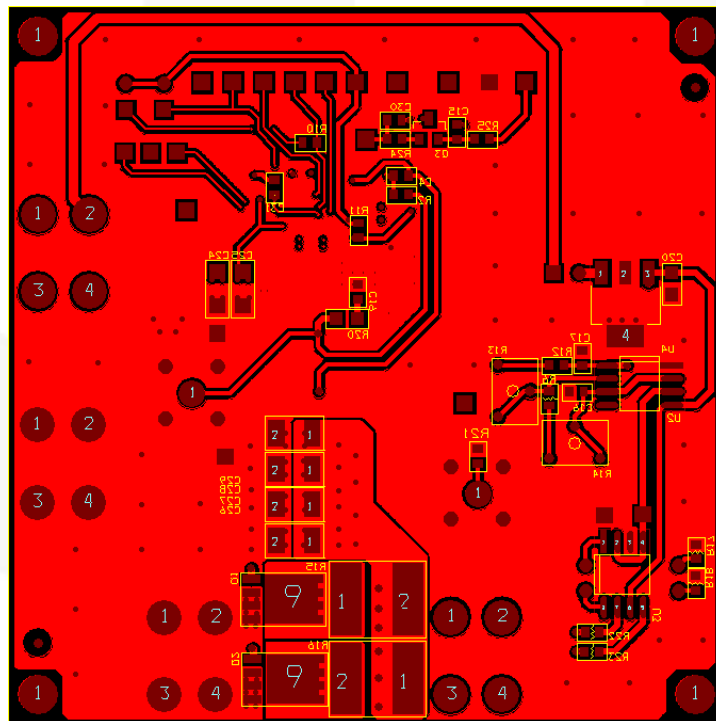

Figure 8. Bottom Side

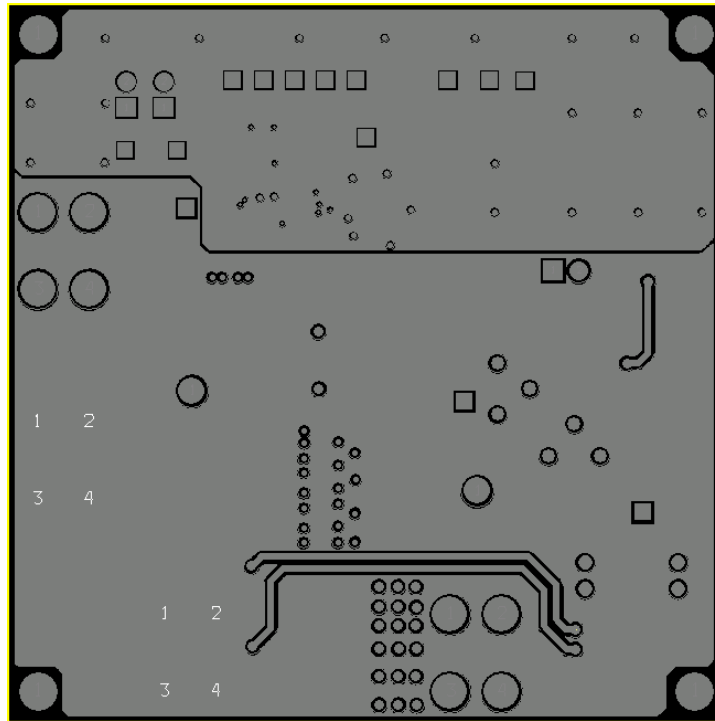

Figure 9. Inner Layer 1

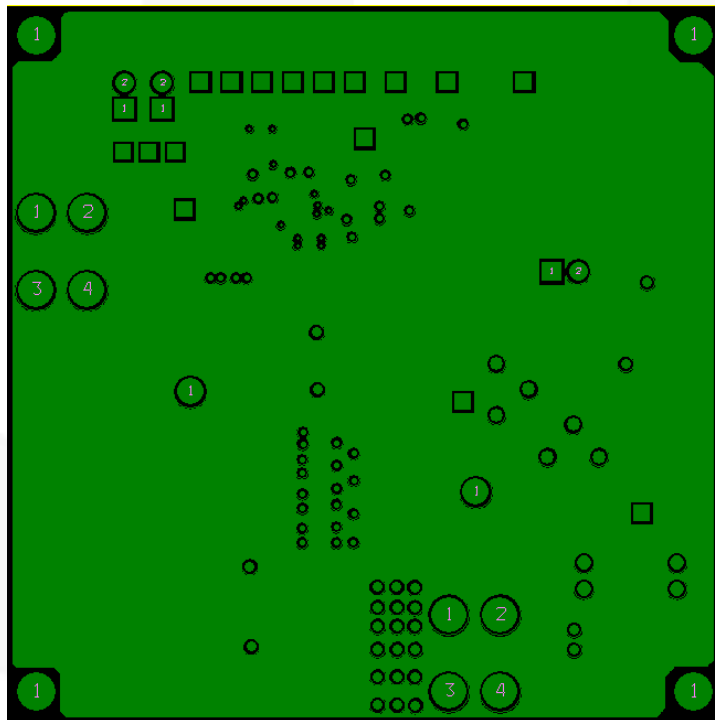

Figure 10. Inner Layer 2

11. Bills of Materials

Table 5. BOM for FAN2306, FAN2356, FAN23SV06, FAN23SV56, FAN2306M, and FAN23SV06P

Reference	Value	Description	Manufacturer PN	Manufacturer	Case
C1	10 μ F	Capacitor, SMD, Ceramic, X7R, 25 V	TMK316B7106KL-TD	Taiyo Yuden	1206
C2	10 μ F	Capacitor, SMD, Ceramic, X7R, 25 V	TMK316B7106KL-TD	Taiyo Yuden	1206
C3	0.1 μ F	Capacitor, SMD, Ceramic, X7R, 25 V	C1608X7R1E104K	TDK	0603
C4	0.1 μ F	Capacitor, SMD, Ceramic, X7R, 25 V	C1608X7R1E104K	TDK	0603
C5	100 pF	Capacitor, SMD, Ceramic, NPO, 50 V	C1608COG1H101J	TDK	0603
C7	0.015 μ F	Capacitor, SMD, Ceramic, X7R, 25 V	C1608X7R1E153K	TDK	0603
C8	0.1 μ F	Capacitor, SMD, Ceramic, X7R, 25 V	C1608X7R1E104K	TDK	0603
C9	2.2 μ F	Capacitor, SMD, Ceramic, X5R, 25 V	C1608X5R1E225M	TDK	0603
C10	0.1 μ F	Capacitor, SMD, Ceramic, X7R, 25 V	C1608X7R1E104K	TDK	0603
C18	47 μ F	Capacitor, SMD, Ceramic, 6.3 V	C3216X5R0J476M	TDK	1206
C21	47 μ F	Capacitor, SMD, Ceramic, 6.3 V	C3216X5R0J476M	TDK	1206
C22	47 μ F	Capacitor, SMD, Ceramic, 6.3 V	C3216X5R0J476M	TDK	1206
C23	47 μ F	Capacitor, SMD, Ceramic, 6.3 V	C3216X5R0J476M	TDK	1206
R1	0 Ω	Resistor, SMD, 1/10W	ERJ-3GEY0R00V	Panasonic	0603
R2	1.5 k Ω	Resistor, SMD, 1/10W	ERJ-3EKF1501V	Panasonic	0603
R3	10 k Ω	Resistor, SMD, 1/10W	ERJ-3EKF1002V	Panasonic	0603
R4	10 k Ω	Resistor, SMD, 1/10W	ERJ-3EKF1002V	Panasonic	0603
R5 (FAN2306/S V06/06M/SV 06P)	1.58 k Ω	Resistor, SMD, 1/10W	CRCW06031K58FKE A	Vishay Dale	0603
R5 (FAN2356/ SV56)	1.78 k Ω	Resistor, SMD, 1/10W	ERJ-3EKF1781V	Panasonic	0603
R8	1 M Ω	Resistor, SMD, 1/10W	ERJ-3EK1001V	Panasonic	0603
R9	54.9 k Ω	Resistor, SMD, 1/10W	ERJ-3EKF5492V	Panasonic	0603
R10	10 k Ω	Resistor, SMD, 1/10W	ERJ-3EKF1002V	Panasonic	0603
R11	10 Ω	Resistor, SMD, 1/10W	ERJ-3EKF10R0V	Panasonic	0603
R19	0 Ω	Resistor, SMD, 1/10W	ERJ-3GEY0R00V	Panasonic	0603
L1	1.2 μ H	Inductor, SMD	744325120	WE	
U1	FAN23XX/S VXX	TinyBuck 6 A COT Integrated Regulator	FAN23XX/SVXX	Fairchild	MLP 5.5x5
J1-J2, J7-J8		Terminal, 15 A, Screw, Vertical PC Mount	8191	Keystone	
J3,J4,J6		Generic 2-Pin SIP .100 Centers		Samtec	
J12-14, J16-20,J22- J25, J29-J29		Test Pin, Gold, 40 mil	3103-2-00-21-00-00- 08-0 (DS10P11)	Mill-Max (Young Jin)	
J31		Generic 3-Pin SIP Header .100 Centers		Samtec	
PCB		PCB, FAN23XX EB Rev 1.1, Jan 13			

Reference	Value	Description	Manufacturer PN	Manufacturer	Case
C16	0.1 μ F	Capacitor, SMD, Ceramic, 25 V, X7R	C1608X7R1E104K	TDK	0603
C17	0.1 μ F	Capacitor, SMD, Ceramic, 25 V, X7R	C1608X7R1E104K	TDK	0603
C20	22 μ F	Capacitor, SMD, Ceramic, 10 V, X5R	LMK212BJ226MG-T	TAIYO YUDEN	0805
R6	1.2 k Ω	Resistor, SMD, 1/10W	ERJ-3EKF1201V	Panasonic	0603
R12	499 Ω	Resistor, SMD, 1/10W	ERJ-3EKF4990V	Panasonic	0603
R13	10 k Ω	Pot, 0.25W	3266W-1-103LF	Bourns	
R14	25 k Ω	Pot, 0.25W	3266W-1-253LF	Bourns	
R15-R16	0.4 Ω	Resistor, SMD, 1W	PT2512FK-070R4L	Yageo	2512
R17-R18	10 k Ω	Resistor, SMD, 1/10W	ERJ-3EKF1002V	Panasonic	0603
R22	0 Ω	Resistor, SMD, 1/10W	ERJ-3GEY0R00V	Panasonic	0603
R23	0 Ω	Resistor, SMD, 1/10W	ERJ-3GEY0R00V	Panasonic	0603
U2	LM555	Timer	LM555CM	Fairchild	SO8
U3	FAN3226T	Driver	FAN3226TMX	Fairchild	SO8
U4	MIC5239	LDO	MIC5239-5.0YS	Micrel	SOT-223
J3		Generic 2-Pin SIP .100 Centers			
Q1-Q2	FDMS7658 AS	MOSFET	FDMS7658AS	Fairchild	MLP5x6
S1	209-2MS	Switch DIP Top Slide Flush 6-POS	209-2MS	CTS	DIP4

Table 6. BOM for FAN2310, FAN23SV10M, FAN2360, and FAN23SV60

Reference	Value	Description	Manufacturer PN	Manufacturer	Case
C1	10 μ F	Capacitor, SMD, Ceramic, X7R, 25 V	TMK316B7106KL-TD	Taiyo Yuden	1206
C2	10 μ F	Capacitor, SMD, Ceramic, X7R, 25 V	TMK316B7106KL-TD	Taiyo Yuden	1206
C3	0.1 μ F	Capacitor, SMD, Ceramic, X7R, 25 V	C1608X7R1E104K	TDK	0603
C4	0.1 μ F	Capacitor, SMD, Ceramic, X7R, 25 V	C1608X7R1E104K	TDK	0603
C5	100 pF	Capacitor, SMD, Ceramic, NPO, 50 V	C1608COG1H101J	TDK	0603
C7	0.015 μ F	Capacitor, SMD, Ceramic, X7R, 25 V	C1608X7R1E153K	TDK	0603
C8	0.1 μ F	Capacitor, SMD, Ceramic, X7R, 25 V	C1608X7R1E104K	TDK	0603
C9	2.2 μ F	Capacitor, SMD, Ceramic, X5R, 25 V	C1608X5R1E225M	TDK	0603
C10	0.1 μ F	Capacitor, SMD, Ceramic, X7R, 25 V	C1608X7R1E104K	TDK	0603
C18	47 μ F	Capacitor, SMD, Ceramic, 6.3 V	C3216X5R0J476M	TDK	1206
C21	47 μ F	Capacitor, SMD, Ceramic, 6.3 V	C3216X5R0J476M	TDK	1206
C22	47 μ F	Capacitor, SMD, Ceramic, 6.3 V	C3216X5R0J476M	TDK	1206
C23	47 μ F	Capacitor, SMD, Ceramic, 6.3 V	C3216X5R0J476M	TDK	1206
C24	10 μ F	Capacitor, SMD, Ceramic, X7R, 25 V	TMK316B7106KL-TD	Taiyo Yuden	1206
C28	47 μ F	Capacitor, SMD, Ceramic, 6.3 V	C3216X5R0J476M	TDK	1206
C29	47 μ F	Capacitor, SMD, Ceramic, 6.3 V	C3216X5R0J476M	TDK	1206
R1	0 Ω	Resistor, SMD, 1/10W	ERJ-3GEY0R00V	Panasonic	0603
R2	1.5 k Ω	Resistor, SMD, 1/10W	ERJ-3EKF1501V	Panasonic	0603
R3	10 k Ω	Resistor, SMD, 1/10W	ERJ-3EKF1002V	Panasonic	0603

Reference	Value	Description	Manufacturer PN	Manufacturer	Case
R4	10 kΩ	Resistor, SMD, 1/10W	ERJ-3EKF1002V	Panasonic	0603
R5 (FAN2310/S V10M)	1.47 kΩ	Resistor, SMD, 1/10W	ERJ-3EKF1471V	Panasonic	0603
R5 (FAN2360/S V60)	1.65 kΩ	Resistor, SMD, 1/10W	ERJ-3EKF1651V	Panasonic	0603
R8	1 MΩ	Resistor, SMD, 1/10W	ERJ-3EK1001V	Panasonic	0603
R9	54.9 kΩ	Resistor, SMD, 1/10W	ERJ-3EKF5492V	Panasonic	0603
R10	10 kΩ	Resistor, SMD, 1/10W	ERJ-3EKF1002V	Panasonic	0603
R11	10 Ω	Resistor, SMD, 1/10W	ERJ-3EKF10R0V	Panasonic	0603
R19	0 Ω	Resistor, SMD, 1/10W	ERJ-3GEY0R00V	Panasonic	0603
L1	0.72 μH	Inductor, SMD	744325072	WE	
U1	FAN23XX/S VXX	TinyBuck 10 A COT Integrated Regulator	FAN23XX/SVXX	Fairchild	MLP 5.5x5
J1-J2, J7-J8		Terminal, 15 A, Screw, Vertical. PC Mount	8191	Keystone	
J3, J4, J6		Generic 2-Pin SIP .100 Centers		Samtec	
J12-14, J16- 20, J22-J25, J29-J29		Test Pin, Gold, 40 mil	3103-2-00-21-00-00- 08-0 (DS10P11)	Mill-Max (Young Jin)	
J31		Generic 3-Pin SIP Header .100 Centers		Samtec	
PCB		PCB, FAN23XX EB Rev 1.1, Jan 13			
C16	0.1 μF	Capacitor, SMD, Ceramic, 25 V, X7R	C1608X7R1E104K	TDK	0603
C17	0.1 μF	Capacitor, SMD, Ceramic, 25 V, X7R	C1608X7R1E104K	TDK	0603
C20	22 μF	Capacitor, SMD, Ceramic, 10 V, X5R	LMK212BJ226MG-T	TAIYO YUDEN	0805
R6	1.2 kΩ	Resistor, SMD, 1/10W	ERJ-3EKF1201V	Panasonic	0603
R12	499 Ω	Resistor, SMD, 1/10W	ERJ-3EKF4990V	Panasonic	0603
R13	10 kΩ	Pot, 0.25W	3266W-1-103LF	Bourns	
R14	25 kΩ	Pot, 0.25W	3266W-1-253LF	Bourns	
R15-R16	0.24 Ω	Resistor, SMD, 1W	ERJ-1TRQFR24U	Panasonic	2512
R17-R18	10 kΩ	Resistor, SMD, 1/10W	ERJ-3EKF1002V	Panasonic	0603
R22	0 Ω	Resistor, SMD, 1/10W	ERJ-3GEY0R00V	Panasonic	0603
R23	0 Ω	Resistor, SMD, 1/10W	ERJ-3GEY0R00V	Panasonic	0603
U2	LM555	Timer	LM555CM	Fairchild	SO8
U3	FAN3226T	Driver	FAN3226TMX	Fairchild	SO8
U4	MIC5239	LDO	MIC5239-5.0YS	Micrel	SOT- 223
J3		Generic 2-Pin SIP .100 Centers			
Q1-Q2	FDMS7658 AS	MOSFET	FDMS7658AS	Fairchild	MLP5x 6
S1	209-2MS	Switch DIP Top Slide Flush 6-POS	209-2MS	CTS	DIP4

Table 7. BOM for FAN2315, FAN23SV15M, FAN2365, and FAN23SV65

Reference	Value	Description	Manufacturer PN	Manufacturer	Case
C1	10 μ F	Capacitor, SMD, Ceramic, X7R, 25 V	TMK316B7106KL-TD	Taiyo Yuden	1206
C2	10 μ F	Capacitor, SMD, Ceramic, X7R, 25 V	TMK316B7106KL-TD	Taiyo Yuden	1206
C3	0.1 μ F	Capacitor, SMD, Ceramic, X7R, 25 V	C1608X7R1E104K	TDK	0603
C4	0.1 μ F	Capacitor, SMD, Ceramic, X7R, 25 V	C1608X7R1E104K	TDK	0603
C5	100 pF	Capacitor, SMD, Ceramic, NPO, 50 V	C1608COG1H101J	TDK	0603
C7	0.015 μ F	Capacitor, SMD, Ceramic, X7R, 25 V	C1608X7R1E153K	TDK	0603
C8	0.1 μ F	Capacitor, SMD, Ceramic, X7R, 25 V	C1608X7R1E104K	TDK	0603
C9	2.2 μ F	Capacitor, SMD, Ceramic, X5R, 25 V	C1608X5R1E225M	TDK	0603
C10	0.1 μ F	Capacitor, SMD, Ceramic, X7R, 25 V	C1608X7R1E104K	TDK	0603
C18	47 μ F	Capacitor, SMD, Ceramic, 6.3 V	C3216X5R0J476M	TDK	1206
C21	47 μ F	Capacitor, SMD, Ceramic, 6.3 V	C3216X5R0J476M	TDK	1206
C22	47 μ F	Capacitor, SMD, Ceramic, 6.3 V	C3216X5R0J476M	TDK	1206
C23	47 μ F	Capacitor, SMD, Ceramic, 6.3 V	C3216X5R0J476M	TDK	1206
C24	10 μ F	Capacitor, SMD, Ceramic, X7R, 25 V	TMK316B7106KL-TD	Taiyo Yuden	1206
C25	10 μ F	Capacitor, SMD, Ceramic, X7R, 25 V	TMK316B7106KL-TD	Taiyo Yuden	1206
C26	47 μ F	Capacitor, SMD, Ceramic, 6.3 V	C3216X5R0J476M	TDK	1206
C27	47 μ F	Capacitor, SMD, Ceramic, 6.3 V	C3216X5R0J476M	TDK	1206
C28	47 μ F	Capacitor, SMD, Ceramic, 6.3 V	C3216X5R0J476M	TDK	1206
C29	47 μ F	Capacitor, SMD, Ceramic, 6.3 V	C3216X5R0J476M	TDK	1206
R1	0 Ω	Resistor, SMD, 1/10W	ERJ-3GEY0R00V	Panasonic	0603
R2	1.5 k Ω	Resistor, SMD, 1/10W	ERJ-3EKF1501V	Panasonic	0603
R3	10 k Ω	Resistor, SMD, 1/10W	ERJ-3EKF1002V	Panasonic	0603
R4	10 k Ω	Resistor, SMD, 1/10W	ERJ-3EKF1002V	Panasonic	0603
R5 (FAN2315/S V15M)	1.3 k Ω	Resistor, SMD, 1/10W	ERJ-3EKF1301V	Panasonic	0603
R5 (FAN2365/S V65)	1.4 k Ω	Resistor, SMD, 1/10W	ERJ-3EKF1401V	Panasonic	0603
R8	1 M Ω	Resistor, SMD, 1/10W	ERJ-3EK1001V	Panasonic	0603
R9	54.9 k Ω	Resistor, SMD, 1/10W	ERJ-3EKF5492V	Panasonic	0603
R10	10 k Ω	Resistor, SMD, 1/10W	ERJ-3EKF1002V	Panasonic	0603
R11	10 Ω	Resistor, SMD, 1/10W	ERJ-3EKF10R0V	Panasonic	0603
R19	0 Ω	Resistor, SMD, 1/10W	ERJ-3GEY0R00V	Panasonic	0603
L1	0.56 μ H	Inductor, SMD	744355256	WE	
U1	FAN23XX/S VXX	TinyBuck 15 A COT Integrated Regulator	FAN23XX/SVXX	Fairchild	MLP 5.5x5
J1-J2, J7-J8		Terminal, 15 A, Screw, Vertical PC Mount	8191	Keystone	

Reference	Value	Description	Manufacturer PN	Manufacturer	Case
J3,J4,J6		Generic 2-Pin SIP .100 Centers		Samtec	
J12-14, J16-20,J22- J25, J29-J29		Test Pin, Gold, 40mil	3103-2-00-21-00- 00-08-0 (DS10P11)	Mill-Max (Young Jin)	
J31		Generic 3-Pin SIP Header .100 Centers		Samtec	
PCB		PCB, FAN23XX EB Rev 1.1, Jan 13			
C16	0.1 μ F	Capacitor, SMD, Ceramic, 25 V, X7R	C1608X7R1E104K	TDK	0603
C17	0.1 μ F	Capacitor, SMD, Ceramic, 25 V, X7R	C1608X7R1E104K	TDK	0603
C20	22 μ F	Capacitor, SMD, Ceramic, 10 V, X5R	LMK212BJ226MG- T	TAIYO YUDEN	0805
R6	1.2 k Ω	Resistor, SMD, 1/10W	ERJ-3EKF1201V	Panasonic	0603
R12	499 Ω	Resistor, SMD, 1/10W	ERJ-3EKF4990V	Panasonic	0603
R13	10 k Ω	Pot, 0.25W	3266W-1-103LF	Bourns	
R14	25 k Ω	Pot, 0.25W	3266W-1-253LF	Bourns	
R15-R16	0.15 Ω	Resistor, SMD, 1W	PT2512FK- 070R15L	Yageo	2512
R17-R18	10 k Ω	Resistor, SMD, 1/10W	ERJ-3EKF1002V	Panasonic	0603
R22	0 Ω	Resistor, SMD, 1/10W	ERJ-3GEY0R00V	Panasonic	0603
R23	0 Ω	Resistor, SMD, 1/10W	ERJ-3GEY0R00V	Panasonic	0603
U2	LM555	Timer	LM555CM	Fairchild	SO8
U3	FAN3226T	Driver	FAN3226TMX	Fairchild	SO8
U4	MIC5239	LDO	MIC5239-5.0YS	Micrel	SOT- 223
J3		Generic 2-Pin SIP .100 Centers			
Q1-Q2	FDMS7658 AS	MOSFET	FDMS7658AS	Fairchild	MLP5x 6
S1	209-2MS	Switch DIP Top Slide Flush 6-POS	209-2MS	CTS	DIP4

12. Revision History

Rev.	Date	Description
0.0.1	September 2012	Draft with BOMs added
0.0.2	October 2012	Prepare for public
0.0.3	May 2013	Updated contents and BOM
1.0.0	June 2013	Added Evaluation Board number on Table 1 & Released

WARNING AND DISCLAIMER

Replace components on the Evaluation Board only with those parts shown on the parts list (or Bill of Materials) in the Users' Guide. Contact an authorized Fairchild representative with any questions.

This board is intended to be used by certified professionals, in a lab environment, following proper safety procedures. Use at your own risk. The Evaluation board (or kit) is for demonstration purposes only and neither the Board nor this User's Guide constitute a sales contract or create any kind of warranty, whether express or implied, as to the applications or products involved. Fairchild warrants that its products meet Fairchild's published specifications, but does not guarantee that its products work in any specific application. Fairchild reserves the right to make changes without notice to any products described herein to improve reliability, function, or design. Either the applicable sales contract signed by Fairchild and Buyer or, if no contract exists, Fairchild's standard Terms and Conditions on the back of Fairchild invoices, govern the terms of sale of the products described herein.

DISCLAIMER

FAIRCHILD SEMICONDUCTOR RESERVES THE RIGHT TO MAKE CHANGES WITHOUT FURTHER NOTICE TO ANY PRODUCTS HEREIN TO IMPROVE RELIABILITY, FUNCTION, OR DESIGN. FAIRCHILD DOES NOT ASSUME ANY LIABILITY ARISING OUT OF THE APPLICATION OR USE OF ANY PRODUCT OR CIRCUIT DESCRIBED HEREIN; NEITHER DOES IT CONVEY ANY LICENSE UNDER ITS PATENT RIGHTS, NOR THE RIGHTS OF OTHERS.

LIFE SUPPORT POLICY

FAIRCHILD'S PRODUCTS ARE NOT AUTHORIZED FOR USE AS CRITICAL COMPONENTS IN LIFE SUPPORT DEVICES OR SYSTEMS WITHOUT THE EXPRESS WRITTEN APPROVAL OF THE PRESIDENT OF FAIRCHILD SEMICONDUCTOR CORPORATION.

As used herein:

- Life support devices or systems are devices or systems which, (a) are intended for surgical implant into the body, or (b) support or sustain life, or (c) whose failure to perform when properly used in accordance with instructions for use provided in the labeling, can be reasonably expected to result in significant injury to the user.
- A critical component is any component of a life support device or system whose failure to perform can be reasonably expected to cause the failure of the life support device or system, or to affect its safety or effectiveness.

ANTI-COUNTERFEITING POLICY

Fairchild Semiconductor Corporation's Anti-Counterfeiting Policy. Fairchild's Anti-Counterfeiting Policy is also stated on our external website, www.fairchildsemi.com, under Sales Support.

Counterfeiting of semiconductor parts is a growing problem in the industry. All manufacturers of semiconductor products are experiencing counterfeiting of their parts. Customers who inadvertently purchase counterfeit parts experience many problems such as loss of brand reputation, substandard performance, failed applications, and increased cost of production and manufacturing delays. Fairchild is taking strong measures to protect ourselves and our customers from the proliferation of counterfeit parts. Fairchild strongly encourages customers to purchase Fairchild parts either directly from Fairchild or from Authorized Fairchild Distributors who are listed by country on our web page cited above. Products customers buy either from Fairchild directly or from Authorized Fairchild Distributors are genuine parts, have full traceability, meet Fairchild's quality standards for handling and storage and provide access to Fairchild's full range of up-to-date technical and product information. Fairchild and our Authorized Distributors will stand behind all warranties and will appropriately address any warranty issues that may arise. Fairchild will not provide any warranty coverage or other assistance for parts bought from Unauthorized Sources. Fairchild is committed to combat this global problem and encourage our customers to do their part in stopping this practice by buying direct or from authorized distributors.

EXPORT COMPLIANCE STATEMENT

These commodities, technology, or software were exported from the United States in accordance with the Export Administration Regulations for the ultimate destination listed on the commercial invoice. Diversion contrary to U.S. law is prohibited.

U.S. origin products and products made with U.S. origin technology are subject to U.S. Re-export laws. In the event of re-export, the user will be responsible to ensure the appropriate U.S. export regulations are followed.