



nRF9X5™

Single Chip 433/868/915 MHz Radio Transceiver

SoC 0.18µm CMOS – RF - Microcontroller - Peripherals - ADC - Voltage regulators

www.BDTIC.com/NORDIC



NORDIC
SEMICONDUCTOR

nRF9E5 – NORDIC ALL IN ONE SINGLE CHIP SOLUTION FOR LONG RANGE

System-on-Chip 0.18µm CMOS

430 - 435MHz

- 100dBm sensitivity

862 - 870MHz

902 - 928MHz

On-chip voltage regulators

5x5mm size

-40 to +85°C

1.9 - 3.6V

+10dBm Pout



Introducing the nRF9E5 multiband transceiver for long range applications, highly integrated device, with 8051 MCU, 4-channel 12 bit ADC and peripherals

The nRF9E5 is designed to offer the user a ultimate solution, with an ease of use, integration and performance that is groundbreaking. Every effort has been paid to details which are typically encountered as a difficulty, in both of PCB and software development.

All critical passive components are integrated on the chip, easing hardware layout issues, as well as lowering the Bill of Material. The RF transceiver unit has a separate protocol pre-processor, performing address decoding, CRC checking and buffering of data in receive and transmit. This is coupled tightly with the on-chip 8051 core enabling a unique low power design and a easy radio protocol design. Also included in the nRF9E5 is a state of the art low power multi channel ADC, and extensive I/O peripherals for the ultimate balanced design.

The nRF9E5 is manufactured in an ultra modern 0.18µm CMOS process, and offered in an extremely small 5x5mm QFN for high volume production.

RF Specifications

- 430-435MHz
- 862-928MHz
- 100kHz channel resolution @ 433MHz
- 200kHz channel resolution @ 868/915MHz
- 10dBm maximum output power
- -100dBm typical sensitivity
- GFSK modulation for efficient output spectrum
- Channel switching time <650µs
- RF tested

General specifications

- -40°C to + 85°C operation
- 1.9 - 3.6V voltage supply, on chip voltage regulator
- 32 pin QFN package 5x5mm
- Few external components, Crystal, resistor and 4KB EEPROM

Ease of use

- Close integration of RF, 8051MCU, ADC and peripherals
- Protocol pre-processing on-chip
- Low threshold for software development
- Ready made SW and HW examples available
- Supported by advanced 3rd party SW tools
- No trimming in production
- Smallest available BOM & footprint
- No need for external SAW filter

Embedded RF features

- 8 or 16 bit CRC computation in RX and TX
- Address stripping in RX - 1 to 4 Byte address
- Retransmit function
- Address Match function in RX
- Data ready function in RX and Tx
- Low power receive mode
- 0 - 50Kbit/sec datarate
- ShockBurst
- Carrier detect function
- 0-32 Byte Data packages

Performance and quality

- GFSK modulation for efficient output spectrum
- Robust against PCB noise with on chip voltage regulator
- High EMC performance
- Support for flexible frequency hopping
- RF tested

MCU features nRF9E5

- 4KByte program RAM
- 256Byte data RAM
- 0.5-20MHz clock
- 4-20 clock cycle instruction
- Scalable low power modes
- Programmable wakeup

Embedded peripherals nRF9E5

- Programmable PWM (Pulse Width Modulation)
- UART
- SPI
- 3 timers
- 4 channel 12 bit ADC
- Battery Monitoring
- I/O pins with 10mA drive

www.BDTIC.com/NORDIC

nRF

Embedded features in nRF9E5 and nRF905 to reduce Bill of Material (BOM) and to improve ease of use

Internal voltage regulator and robust architecture

A key element in the nRF9E5 and nRF905 is the attention which has been paid to the on chip power supply and filtering. The net result is that nRF9E5 and nRF905 can run directly from most known battery technologies without any extra external components, and are very robust in the presence of PCB as well as EMC noise.

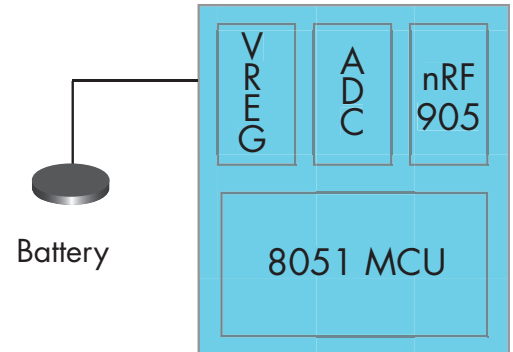

ShockBurst™ technology to reduce current consumption, BOM and improve ease of SW development

The nRF9E5 and nRF905 use ShockBurst™ technology to allow the embedded 8051 MCU to clock in data at the desired speed into the transceiver. The transceiver computes the CRC checksum and buffers up data in an on-chip FIFO for transmission. At the receiving end the opposite takes place. The transceiver buffers up data, decodes the address and computes the CRC checksum, allowing the MCU to clock out data, with extensive control signals available to ease the protocol design. The net result is a considerable reduction in average current, freeing up extensive resources for the MCU, and thereby reducing the required MIPS and memory needed to perform a TX or RX operation compared to a conventional radio architecture.

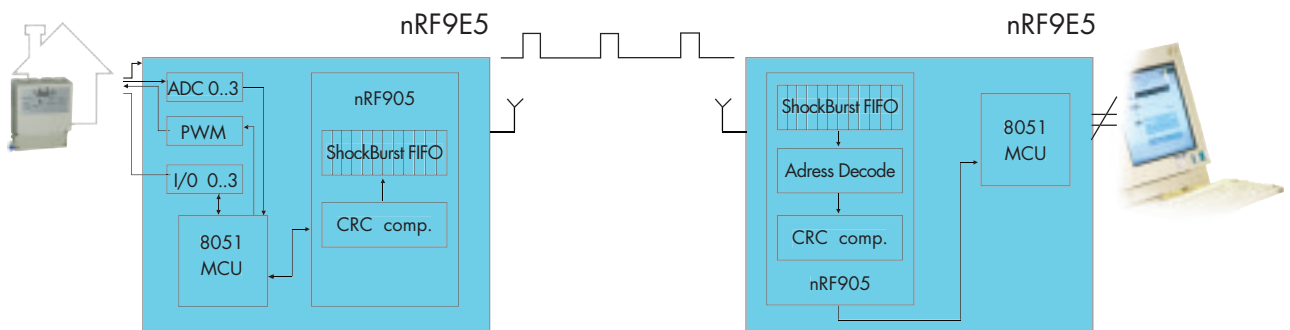

Nordic Semiconductor embedded RF

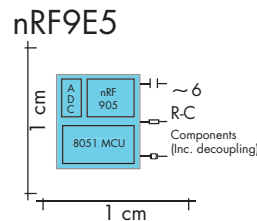
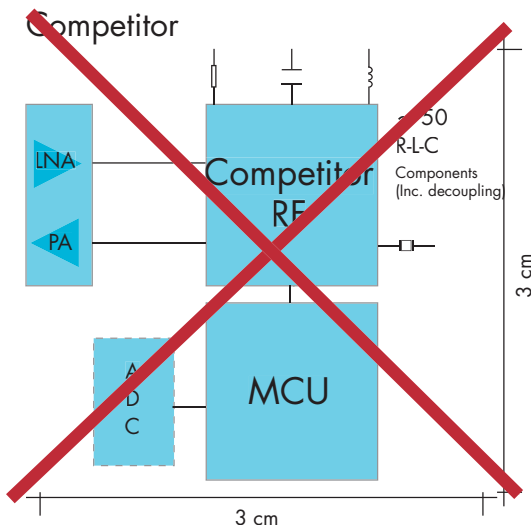

Using the nRF9E5 for an embedded RF design will allow substantial savings in cost, component count and board size, whilst easing design and increasing reliability.

nRF9E5 with external components

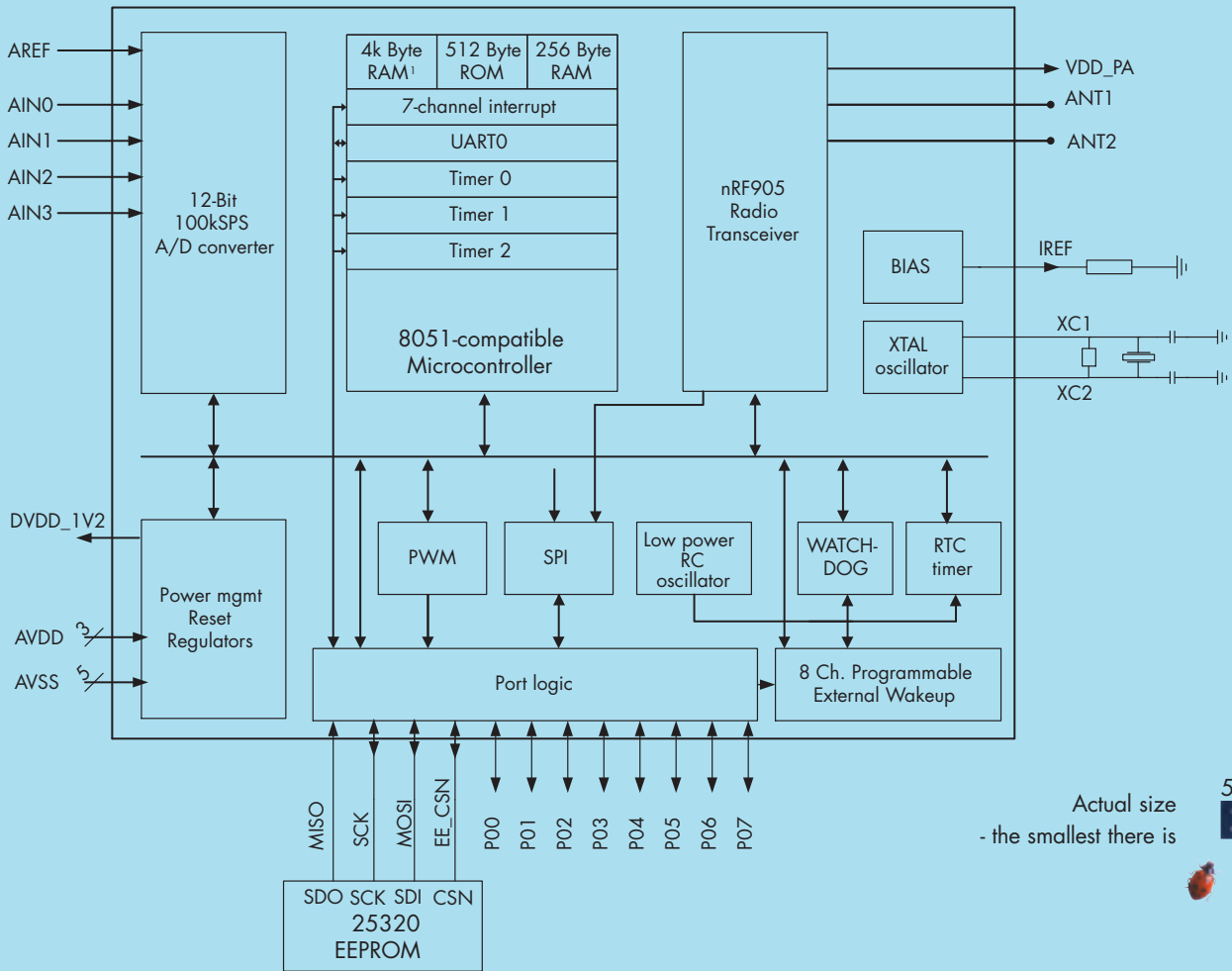

Actual size
- the smallest there is

5 mm



Extremely low current consumption	
Datarate - mode	Current consumption (typ)
Power Down	< 2.5µA
StandBy @ 4MHz, upclk off.	12µA
RX @ 433/868/915MHz	12.5mA
RX (Reduced power mode)	10.5mA
Tx @ 10dBm POUT, 433/868/915MHz	28mA
Tx @ 2dBm POUT, 433/868/915MHz	19mA
Tx @ -6dBm POUT, 433/868/915MHz	13mA
Tx @ -14dBm POUT, 433/868/915MHz	10mA
Supply current for 8051 MCU @ 16MHz @ 3V	3mA
Supply current for 8051 MCU @ 4MHz @ 3V	<1mA

nRF 9E5/905

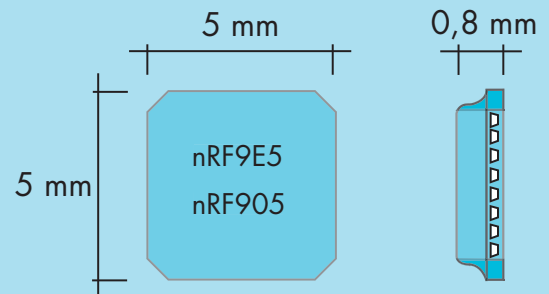

nRF905 with external components

Actual size
- the smallest there is

5 mm

The nRF905 transceiver is the smallest, lowest Bill of Material transceiver for 433/868 and 915MHz applications available today

Launched as a powerful complement to the nRF9E5™ the nRF905™ can be used in all applications where investments have already been made in software for other microcontroller architectures, or where the requirements of peripherals or I/O exceeds that offered by the nRF9E5. The radioarchitecture of the nRF905™ covers most of the frequency bands used worldwide, with a perfect balance between power consumption, voltage supply and features.

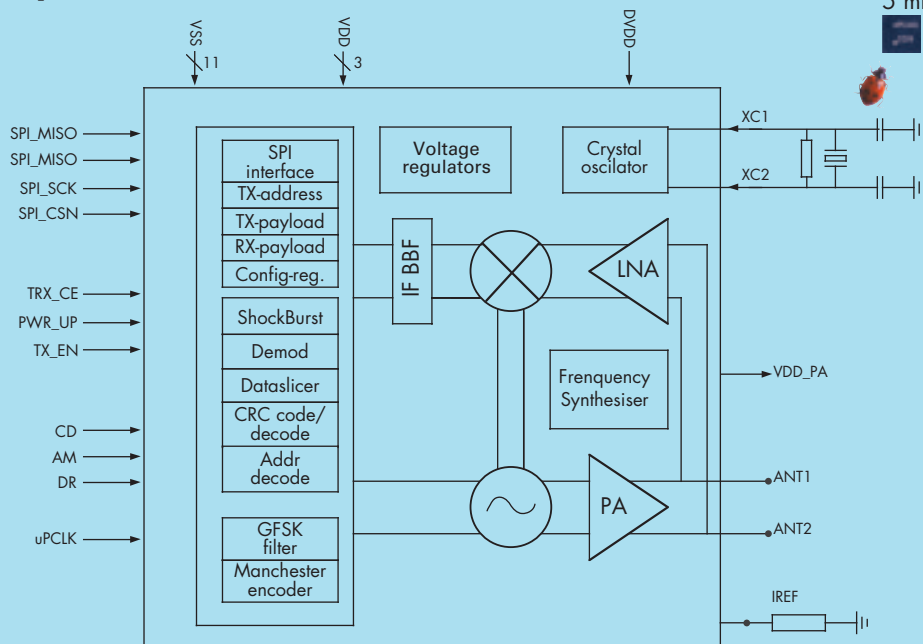

nRF9E5 and nRF905 applications

nRF9E5 and nRF905 are used in applications where size, price and power consumption coupled with long range are important parameters. The nRF9E5 integration with MCU, memory and ADC will fit almost all

applications. The nRF905 is ideally suited for applications where the required number of I/O and available memory is higher than for the nRF9E5, or where already developed software dictates the choice of microcontroller.

RF ID and Point of Sale

With its low Bill of Material the nRF9E5 is a single chip solution for active RF ID and Point of Sale applications. It offers a low cost interface for various readers and tags and offers an exceptional power vs range ratio.



Industrial automation

In industrial automation there is an ever-increasing need to monitor and analyse the status or wear and tear of machines and sensors. Using the low power wireless connectivity of the nRF9E5 is a low cost high reliability method of getting access to this data.



Remote meter reading

With the extremely high integration of the nRF905, its high output power and sensitivity can be used to make a single chip long range solutions for remote meter reading

Building automation

Controlling the environment inside buildings can be done at a low installation cost and without wires running across buildings

Security

Frequency hopping and short time on air increases security in applications using the nRF9E5. In Remote Keyless Entry systems the low voltage operation, internal voltage regulator and low current operation of the nRF9E5 increases the battery lifetime.

Features and benefits:

- True single chip GFSK transceiver in a small 32-pin package (32L QFN 5x5mm)
- ShockBurst™ mode for low power operation
- Power supply range 1.9 to 3.6 V
- Multi channel operation
- Channel switching time 650µS
- Extremely low cost Bill Of Material (BOM)
- No need for external SAW filter
- Adjustable output power up to 10dBm
- Carrier detect for "listen before transmit" protocols
- Data Ready signal indicates when valid data package is received or transmitted
- Address Match for detection of incoming package
- Automatic retransmission of data packages
- Automatic CRC and preamble generation
- Low supply current (TX), typical 11mA @ -14dBm output power
- Low supply current (RX), typical 12.5mA in receive mode
- "Green" Pb free

Wireless solutions

Have you ever wanted to...?

- Link devices together
- Monitor the state of a machine
- Remote control something
- Be warned of a critical event
- Transfer data

BUT faced problems with...?

- Distance
- Rugged terrain
- Hazardous areas
- Physical obstructions
- Battery powered applications

WIRELESS SOLUTIONS give:

- Flexibility
- Portability
- Low cost installation
- Scalability

Development tools

The nRF9E5-EVKIT and nRF905-EVKIT are made for low cost evaluation and development. Programming and setup is performed via a PC USB interface. All I/O pins of both devices are available on external connectors, and the evaluation boards themselves are built up of an RF module connected to a carrier board.



nRF9E5-EVKIT

Two boards with nRF9E5 transceiver

- Connectors for ADC interface
- Connectors for Digital I/O and peripherals
- 4 push buttons for user input
- 4 light diodes for output
- Temperature sensor for ADC/range evaluation
- SMA connector for antenna
- Two antennas for SMA connector

Two USB interface boards

- Connects to nRF9E5-EVBOARD
- Connects to PC USB port

CD-ROM with Software and documentation

- PC Interface SW
- Example programmes
- Support for 3rd party development tools:
 - Assemblers - Linkers
 - Compilers - Debugger

nRF905-EVKIT

Two boards with nRF905 transceiver

- Connectors for MCU interface
- SMA connector for antenna
- Two antennas for SMA connector

Two USB interface boards

- Connects to nRF905-EVBOARD
- Connects to PC USB port

CD-ROM with Software and documentation

- PC Interface SW



www.nordicsemi.no e-mail: nrf@nordicsemi.no

Trondheim:

Nordic Semiconductor ASA
Vestre Rosten 81 Phone: +47 72 89 89 00
N-7075 Tiller Fax: +47 72 89 89 89
Norway

Oslo:

Nordic Semiconductor ASA
Hoffsveien 23 Phone: +47 22 51 10 50
P.O. Box 436 Skøyen Fax: +47 22 51 10 99
N-0211 Oslo, Norway

Hong Kong:

Nordic Semiconductor ASA
16/F, Cheung Kong Centre Phone: +852 22 97 23 83
2 Queen's Road Central Fax: +852 22 97 23 40
Hong Kong

