

# RF Performance Test Guidelines

## White Paper

All rights reserved.

Reproduction in whole or in part is prohibited without the prior written permission of the copyright holder.

November 2008

[www.BDTIC.com/NORDIC](http://www.BDTIC.com/NORDIC)

## Liability disclaimer

Nordic Semiconductor ASA reserves the right to make changes without further notice to the product to improve reliability, function or design. Nordic Semiconductor ASA does not assume any liability arising out of the application or use of any product or circuits described herein.

## Life support applications

These products are not designed for use in life support appliances, devices, or systems where malfunction of these products can reasonably be expected to result in personal injury. Nordic Semiconductor ASA customers using or selling these products for use in such applications do so at their own risk and agree to fully indemnify Nordic Semiconductor ASA for any damages resulting from such improper use or sale.

## Contact details

For your nearest dealer, please see <http://www.nordicsemi.no>

Receive available updates automatically by subscribing to eNews from our homepage or check our website regularly for any available updates.

### Main office:

Otto Nielsens vei 12  
7004 Trondheim  
Phone: +47 72 89 89 00  
Fax: +47 72 89 89 89  
[www.nordicsemi.no](http://www.nordicsemi.no)



## Revision History

Date	Version	Description
November 2008	1.0	

## Contents

<b>1</b>	<b>Introduction .....</b>	<b>4</b>
<b>2</b>	<b>Output power .....</b>	<b>5</b>
2.1	Carrier wave output power .....	5
2.1.1	Test method and setup .....	5
2.1.2	Calibration of measurements .....	6
2.2	Carrier wave sweep .....	7
<b>3</b>	<b>Spurious emissions .....</b>	<b>10</b>
3.1	Harmonic output power .....	10
3.1.1	Test method and setup .....	11
3.1.2	Measurement accuracy .....	12
3.2	RX local oscillator leakage .....	12
3.2.1	Test methods and set up .....	13
<b>4</b>	<b>Frequency accuracy .....</b>	<b>15</b>
4.1	Test method and setup .....	15
<b>5</b>	<b>Modulation bandwidth .....</b>	<b>18</b>
5.1	Modulation bandwidth theory .....	18
5.2	Test method and setup .....	22
<b>6</b>	<b>Receiver Sensitivity .....</b>	<b>24</b>
6.1	Receiver sensitivity theory .....	24
6.1.1	Bit Error Rate .....	25
6.1.2	Sensitivity accuracy .....	25
6.1.3	What do sensitivity measurements tell you? .....	27
6.2	Test Method and Configuration .....	28
6.2.1	Test Setup .....	28
6.2.2	Calibration of measurements .....	30
6.2.3	Low cost set up .....	30
<b>7</b>	<b>Receiver selectivity .....</b>	<b>32</b>
7.1	Theory .....	32
7.2	Test Method and Configuration .....	33
7.2.1	Test Setup .....	33
7.2.2	Calibration of measurements .....	35
7.3	Types of interference .....	35
<b>8</b>	<b>Current consumption .....</b>	<b>36</b>
8.1	Static and average current consumption .....	36
8.2	Dynamic current consumption .....	37
8.2.1	Test method and HW setup active current consumption .....	37
8.3	Calculation of average current consumption .....	40
<b>9</b>	<b>Glossary of Terms .....</b>	<b>41</b>

## 1 Introduction

RF front end performance plays a vital role in any RF product and it is also the main area of testing when qualifying your RF application for regulatory standards for RF emissions (like FCC, ETSI and TELEC). This document aims to give you the necessary background for understanding the terminology, how different RF parameters are tested and why it is important to test these parameters. The following are the main tests when verifying the frontend performance of a nRF device:

- Output power
- Frequency accuracy
- Spurious emissions:
  - ▶ Harmonic output power
  - ▶ RX local oscillator leakage
- Deviation and modulation bandwidth
- Receiver sensitivity
- Receiver selectivity
- Current consumption

The general guidelines presented in this document are complemented by device specific application notes that give a brief guide on how to run the various tests on our different radio devices (nRF family). Performance tests must be conducted on more than one unit to avoid misleading conclusions. Running the same test with the same setup on multiple units should give you similar results, if not there may be something wrong with the unit or with your test set-up.

**Note:** The tests described in this document are intended for prototype stage testing. Some of these tests can also be used during production testing while others are too complex and take too much time to be feasible for use in a production line.

## 2 Output power

The output power of a radio is a critical factor for achieving your desired communication range. Output power is also the first test criteria to qualify for regulatory standards for RF emissions (like FCC, ETSI and TELEC).

### 2.1 Carrier wave output power

Although all nRF devices send short packages of data in normal operation, output power is best measured while sending continuously on one frequency. To get this frequency output, modulation (see [chapter 5 on page 18](#)) is turned off, this concentrates all the output power from the nRF device into one frequency called a transmit carrier wave or short TX carrier. With the power concentrated at one frequency instead of spread across the modulation bandwidth you get the absolute maximum power readings (see [chapter 5 on page 18](#)).

Measuring TX carrier output power is the most straightforward of all RF measurements.

#### 2.1.1 Test method and setup

The output power from a radio device in transmit mode is easily measured with a spectrum analyzer in the simple hardware (HW) test setup shown in [Figure 1](#). You should use cables for all output power measurements on a radio device (this type of setup is called a conducted measurement). Using cables is the only way to have a controlled transfer of power from the radio to the measurement equipment. Measuring power accurately over the air requires a fully controlled environment and calibrated antennas, this means you need a calibrated reflection and an echo free (anechoic) chamber.

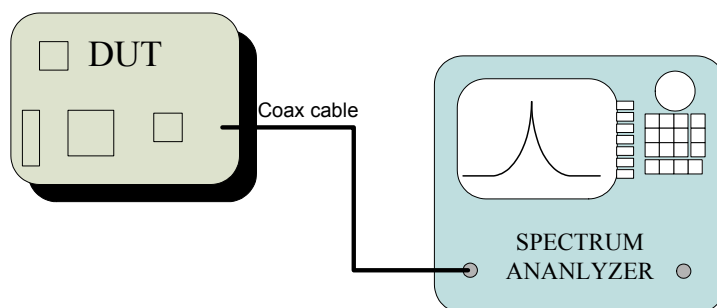

*Figure 1. TX carrier hardware test setup*

The radio circuitry, generally referred to as the Device Under Test (DUT) and the spectrum analyzer are connected with a coaxial or COAX cable. The spectrum analyzer must cover the frequency range you want to measure. The frequency range depends on the operation frequency of the radio you want to measure.

Spectrum analyzers have the following four main configurations that must be set up before testing:

- **Center frequency:** Equal to the RF frequency configured in the DUT.
- **Frequency span:** 1-10 MHz (depending on the DUT).
- **Amplitude:** Must be set higher than the maximum output power of the DUT.
- **Resolution Bandwidth (RBW):** 30kHz- 300kHz depending on the frequency span used. Generally, it is best to set the spectrum analyzer RBW to auto so that it follows the span.

Recommendations on the above parameters are found in the nRF performance test instructions for each nRF device.

The amplitude setting of a spectrum analyzer controls how much gain is set in the input stages of the instrument. Setting the amplitude setting wrong may saturate the input stages and distort the measurements. For example, if the DUT transmits 0 dBm (1 mW) the spectrum analyzer amplitude should be set to +5 dBm (that is, the input signal can be up to +5dBm strong). If set to 0 dBm or lower, the input amplifiers of the spectrum analyzer may saturate. This causes unwanted frequency components showing on the spectrum analyzer screen, making the DUT seem to have a lot of unwanted output frequencies.

The RBW has an impact on how easy it is to read the spectrum and on the accuracy of the output power reading. Using the auto setting (found on most spectrum analyzers) on RBW usually resolves this. [Figure 2](#) is an example of a carrier output spectrum.

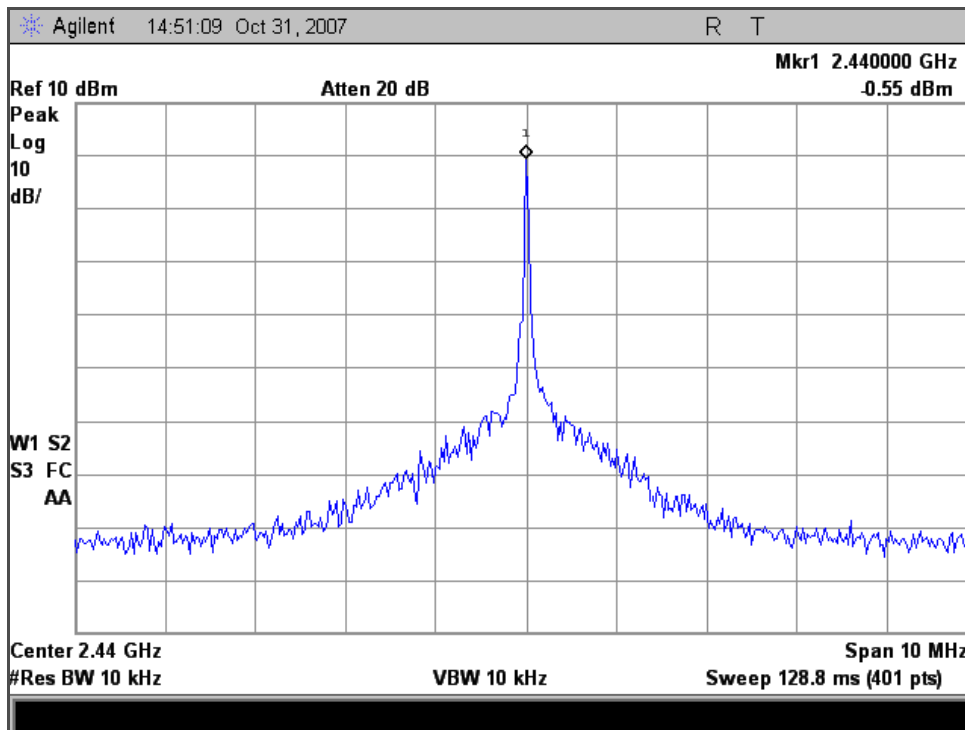

Figure 2. nRF2401 single carrier output spectrum

How to set different nRF devices in a constant carrier transmit mode is described in the nRF performance test instructions for each nRF device.

## 2.1.2 Calibration of measurements

You always lose some of the power the DUT provides in the test cables and connectors when working on high frequency systems like RF. This is called insertion loss and how much loss you have depends on frequency and the type of cable and connectors you are using.

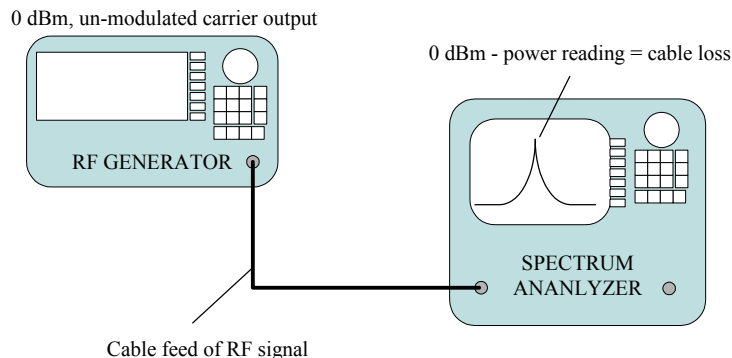

Figure 3. Calibrating DUT output power measurement

To compensate for this loss, measure the insertion loss from the DUT to the spectrum analyzer. You can do this by replacing the DUT with a calibrated RF generator sending a carrier wave with a known output power of, for instance, 0 dBm (Figure 3.). The power level you now measure on the spectrum analyzer should be slightly lower than the output set on the generator, this gives you the insertion loss of the cable and connectors. The insertion loss value should then be added to all your later measurement results. Adding the insertion loss value is called calibrating the test setup because this gives the true output from the DUT.

**Note:** If you do not have a RF generator you can use an estimated loss in RF cables of ~0.5 dB per meter. However, this is only a rough estimate.

The type of connectors you are using must be designed for the frequency you are measuring on. For example, BNC COAX connectors are usually specified for use only up to 1.8 GHz. On a 2.4GHz system these connectors may give a significant loss while SMA COAX connectors, which are still within specification at 2.4GHz (and above), give you very little insertion loss.

## 2.2 Carrier wave sweep

If the DUT can operate over a range of frequencies, called a frequency band (for example, ~80 MHz in the case of a 2.4GHz ISM band radio), it is important that you measure the output power at different frequencies across the DUT's frequency band. This will show you the overall output power performance. If the radio output power is the same across all frequencies, you have verified that your communication range stays the same no matter which frequency is used.

Measuring output power across a frequency band can be done by running the TX carrier test on a few frequencies manually. But, the best way to measure the output power is to program the DUT to make a frequency sweep covering all the frequencies of the band and set up the spectrum analyzer slightly differently from the TX carrier test in [section 2.1](#). The necessary routine to implement a TX carrier wave sweep is

shown in [Figure 4](#). This routine runs consecutive TX carrier wave tests on all available RF channels in the specified band.

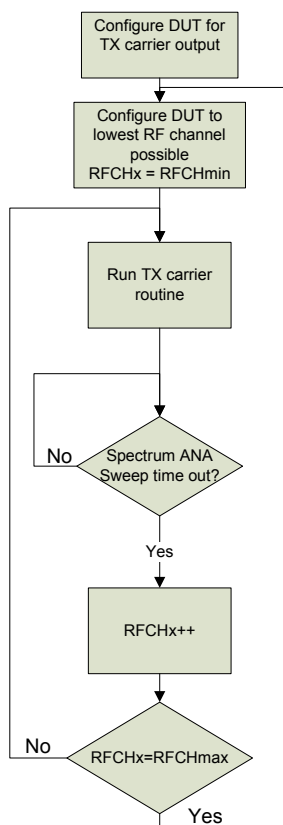

Figure 4. DUT TX carrier sweep flowchart

On some nRF devices the carrier wave sweep must run in an external MCU while other nRF devices have it built in. Please refer to the ‘nRF performance test instructions’ document for each device.

The spectrum analyzer setup should be as follows:

1. **Center Frequency:** Middle of frequency band in use. For example, 2.4GHz: 2.42GHz.
2. **Span:** Wide enough to cover the entire band in use. For example, 2.4GHz: > 83 MHz.
3. **RBW:** Auto like in the TX carrier wave test.
4. **Amplitude:** Higher than the maximum DUT output power, same as in the TX carrier wave test.
5. Peak or max hold measurement enabled.

Since the DUT only transmits on one frequency at a time, the spectrum analyzer must utilize a feature called peak hold measurement to gradually capture all the carrier frequencies across the band. This feature enables the spectrum analyzer to store all the maximum power readings it has captured. The peak hold feature is found under the AVERAGE or TRACE menu on most spectrum analyzers.

As shown in [Figure 4](#), the carrier wave sweep depends on a spectrum analyzer sweep time out. This means that to capture all TX carriers fast, the DUT should keep the carrier on one channel for as long as it takes the spectrum analyzer to sweep across the whole measurement span. The reason it takes the spectrum analyzer a little time to measure the whole frequency span is because it does many consecutive power measurements on small segments of the span set by the RBW.



This sweep time varies a lot from analyzer to analyzer, you can usually find it listed on the spectrum analyzer's main screen directly or in the SWEEP menu of each instrument. In [Figure 5](#), you can find the sweep time (4 ms) listed in the lower right corner of the screen. This sweep time may be up to several hundred milliseconds depending on the processing speed of the spectrum analyzer.

What you want to achieve is shown in [Figure 5](#). This figure shows the TX carrier output on all the possible frequencies this radio device can use. From the envelope formed by the TX carrier wave sweep you can see if the output power is level across the band or is stronger in particular areas.

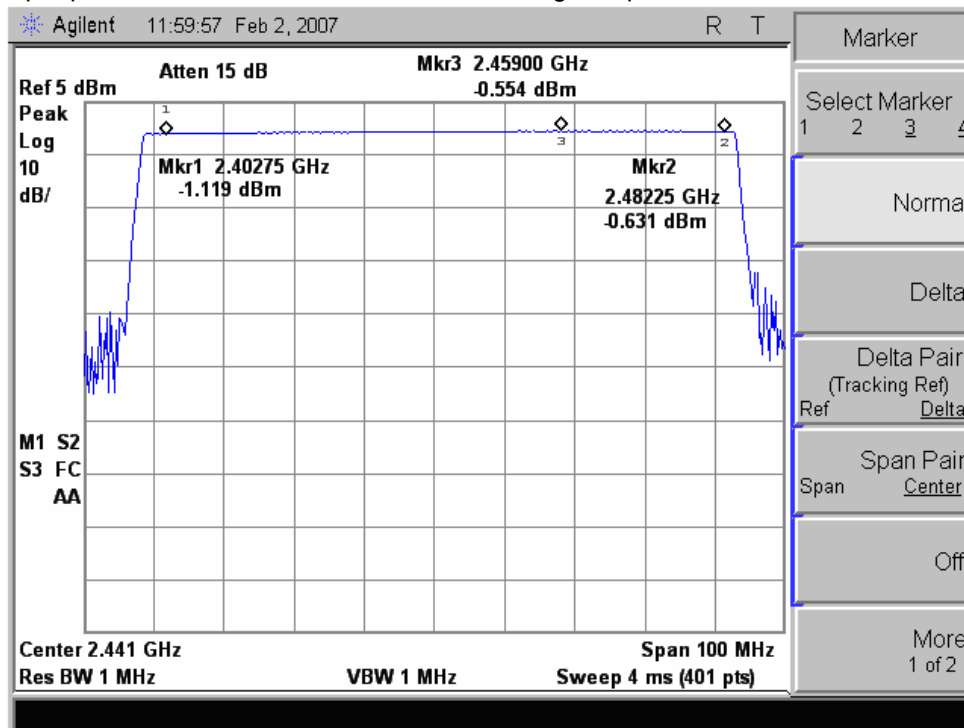

Figure 5. TX carrier frequency sweep across the 2.4GHz band

The TX output power of all nRF devices is tested during our production to guarantee that the devices provide the same power across the band. Therefore, the carrier wave sweep test primarily shows the frequency response of the antenna matching circuitry found between the nRF device and the antenna on your PCB. You can use this information to optimize the antenna matching network, a vital task in any RF design.

### 3 Spurious emissions

Spurious emissions is radiation from a RF device that is outside the appropriate frequency band. These emissions act as noise for RF systems operating in other frequency bands. The most important spurious emissions are harmonics of the RF output in TX mode and Local Oscillator (LO) leakage in RX mode. Keeping these unwanted RF emissions under control is one of the main criteria for qualifying for governmental regulations like FCC, ETSI or TELEC.

#### 3.1 Harmonic output power

Harmonic output is spurious (unwanted) TX power that appears on harmonics or multiples of the RF frequency used. In the case of a 2.4GHz system these appear at  $2 \times 2.4\text{GHz} = 4.8\text{GHz}$ ,  $3 \times 2.4\text{GHz} = 7.2\text{GHz}$ ,  $4 \times 2.4\text{GHz}$ , and so on. In [Figure 6](#), a wide band spectrum analyzer measurement shows the desired output power on 2.4GHz and the unwanted harmonic outputs from a nRF device.

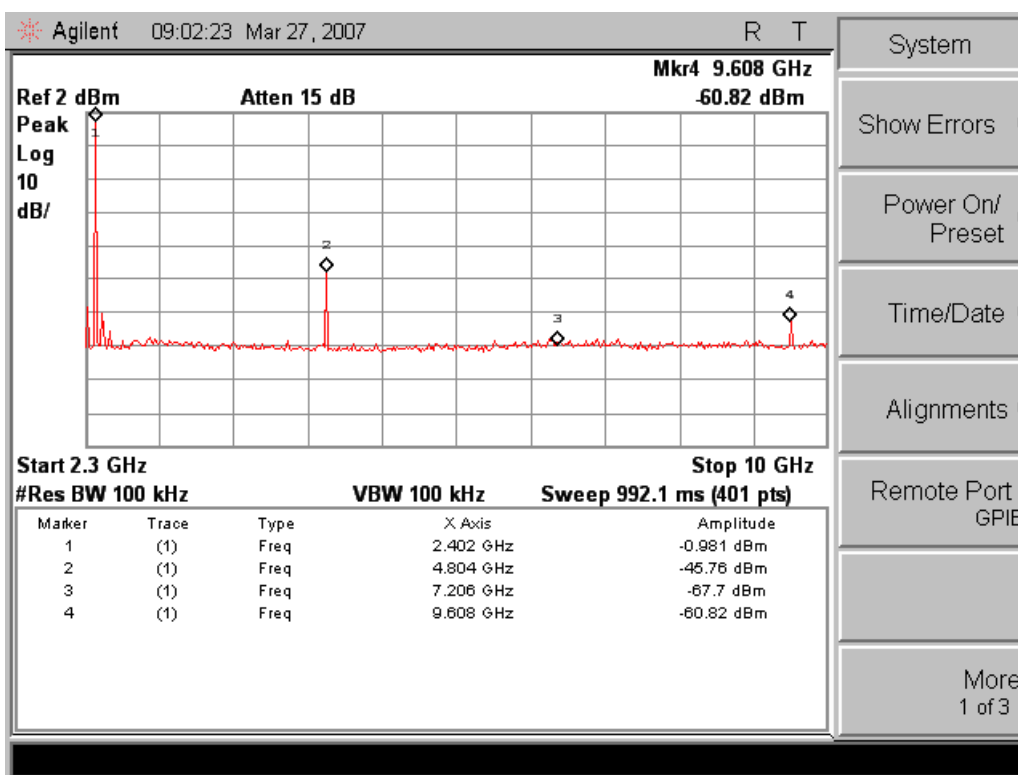

Figure 6. TX harmonic output power

The maximum power allowed on the harmonics depends on regulatory standards and you must identify which regulations you need to pass. Each nRF device is made to comply with certain regulatory standards.

nRF devices suppress harmonics to a certain degree while the remaining filtering is done in the antenna matching network found on the PCB outside the nRF device. When you are testing and optimizing an application for maximum RF output power you must always check the harmonic output. An application with good output power is useless unless you also meet regulatory requirements on maximum harmonic output power level.

### 3.1.1 Test method and setup

The spurious emissions tests use the same HW setup as the TX carrier wave output power tests. To get accurate measurements you must calibrate for cable insertion loss on each of the frequencies you conduct tests on.

The DUT configuration and test routine (single channel or carrier sweep) from the output power measurements is used in this test. You need to configure the spectrum analyzer to the correct frequency range.

The spectrum analyzer setup should be as follows:

- **Center frequency:**
  - ▶ TX carrier wave: N times the RF frequency configured in the DUT where N = 2, 3, and so on.
  - ▶ TX carrier wave sweep: N times center of RF band in use. N = 2, 3, and so on.
- **Frequency span:**
  - ▶ TX carrier wave setup: the same as TX carrier wave output power.
  - ▶ TX carrier wave sweep setup: N times the span used at the TX carrier sweep test.
- **Amplitude:** the same as TX output power test.

Keeping the amplitude at the same level that is used for the TX output power test is very important. Although the main carrier is now outside the view on the spectrum analyzer screen and the output power on the harmonic you measure on should be at least 30 to 40 dB lower than the main carrier output, the spectrum analyzer input is still subjected to the power from the main carrier. Reducing the amplitude setting may lead to saturation of the spectrum analyzer input stages.

[Figure 7.](#) shows a close up of the 2. harmonic (2x TX frequency) of a 2.4GHz nRF device. The device is running a TX carrier sweep and [Figure 7.](#) shows all the 2. harmonic frequencies the device can emit.

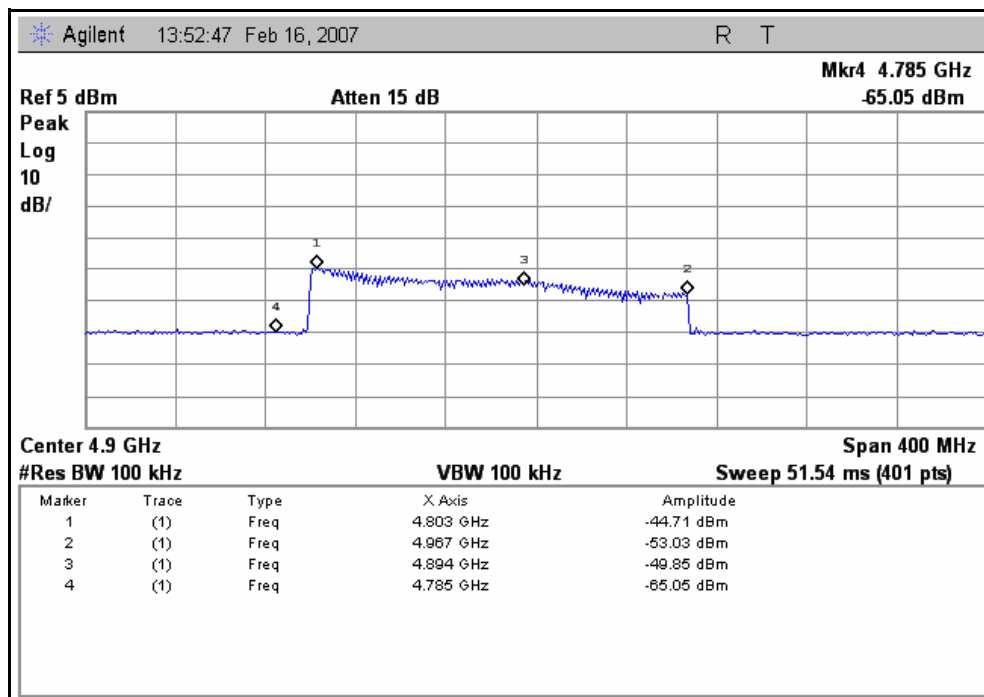

Figure 7. Harmonic output power

### 3.1.2 Measurement accuracy

When conducting spectrum analyzer measurements on weak spurious components it is important to remember that power levels measured on frequency components that are less than 6 dB above the noise floor of the spectrum analyzer (the line you see on the spectrum analyzer screen without any input, see marker 4 in [Figure 7.](#)), will be very inaccurate.

If any spurious components are less than 6 dB above the noise floor in your measurements you must reduce the frequency span and/or RBW to reduce the spectrum analyzer noise floor. You may need to measure segments of the harmonic spectrum individually.

In [Figure 8.](#) the RBW of the spectrum analyzer is set deliberately high so the noise floor of the spectrum analyzer is too high. The level of some of the harmonic frequency components as shown in [Figure 7.](#) are now, in [Figure 8.](#)) less than 6 dB higher than the noise floor and consequently the power level measured is different from the correct setup used in [Figure 7.](#) Setting the RBW high raises all the measured power levels slightly higher. This is because the wider RBW measures power over a wider bandwidth for each point drawn on the spectrum analyzer screen. What is important to note is that in [Figure 8.](#) the error made by the spectrum analyzer becomes bigger the closer it is to the noise floor.

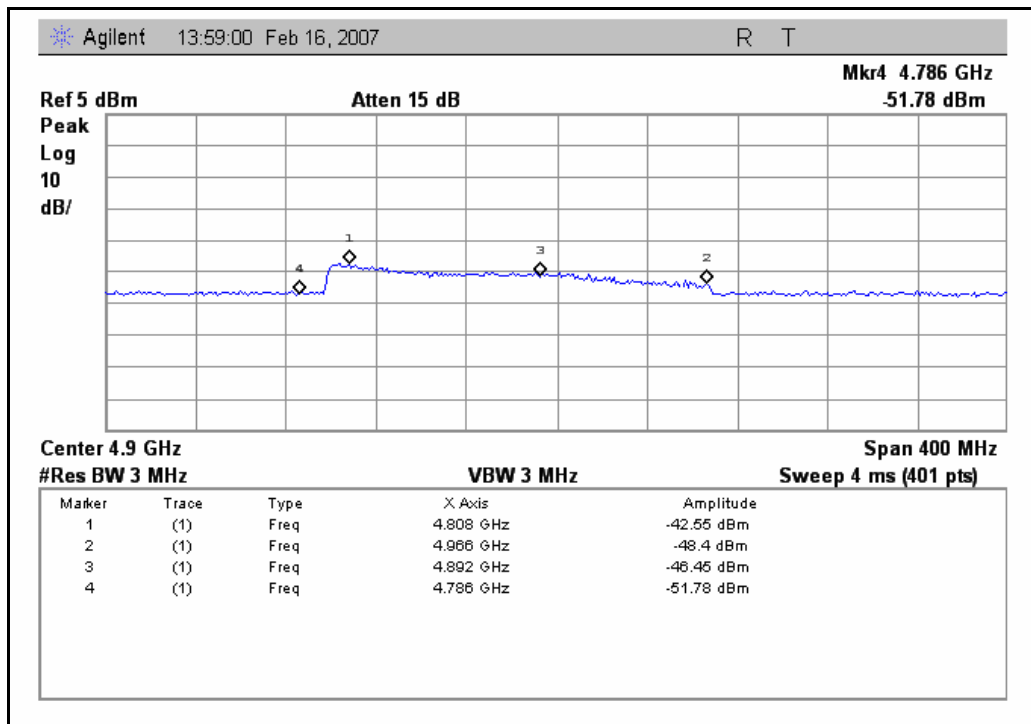

Figure 8. Harmonic output power measured with incorrect spectrum analyzer configuration

### 3.2 RX local oscillator leakage

RX local oscillator leakage is an unwanted RF power emission from a RF device when it is in receive mode. It is one of the critical parameters you must pass in order to meet the regulatory standards (FCC, ETSI/CE) for your end product.

All nRF receivers first multiply (mix) the incoming RF signal with a RF signal generated locally in the receiver to convert the received RF signal to a base band signal. This local RF signal is made in the Local

Oscillator (LO) and some of the output power from this oscillator leaks out to the antenna interface through the receiver front end low noise amplifiers. So, even in receive mode a RF device emits some very weak spurious frequency components.

This is a common effect in radios and the maximum level on these emitted frequencies is set in regulatory standards. The level of these spurious emissions depends mainly on the actual output from the device, but a poorly tuned antenna matching network also contributes. This means that you need to conduct the RX local oscillator test as well to verify the full performance of the antenna matching network.

The frequencies where this spurious output is found depends on the design of each nRF device family and can be found in the nRF performance test instructions document for each nRF device.

### 3.2.1 Test methods and set up

Use the same HW setup and routines used for the TX output power measurements, but configure the DUT to receive mode. To measure LO leakage on all possible RF channels run the TX carrier sweep test routine.

The spectrum analyzer setup should be as follows:

- **Center frequency and span:** According to the LO frequency range of each radio device.
- **Amplitude:** Since there is no powerful carrier output in this test, the amplitude only has to be higher than the max LO leakage output. Start with -30 to -40 dBm and reduce this until you have a good view of the LO spurious components on the analyzer screen. To get accurate measurements you need to have a 6 dB margin from the spectrum analyzer noise floor to the output power level of the LO leakage.
- **RBW:** You may need to set a RBW lower than the one you get on the auto setting to get the necessary 6 dB margin to the spectrum analyzer noise floor.

[Figure 9](#) shows an example of the LO leakage measured on the nRF24L01 device. The device scans through all RX channels and the spectrum analyzer captures the LO leakage in each RF channel with a peak hold measurement. For this device the spectrum analyzer is set up with center frequency: 2.8 GHz, Span: 200MHz, Amplitude -40 dBm and RBW: 300kHz to give a good picture of the LO leakage.

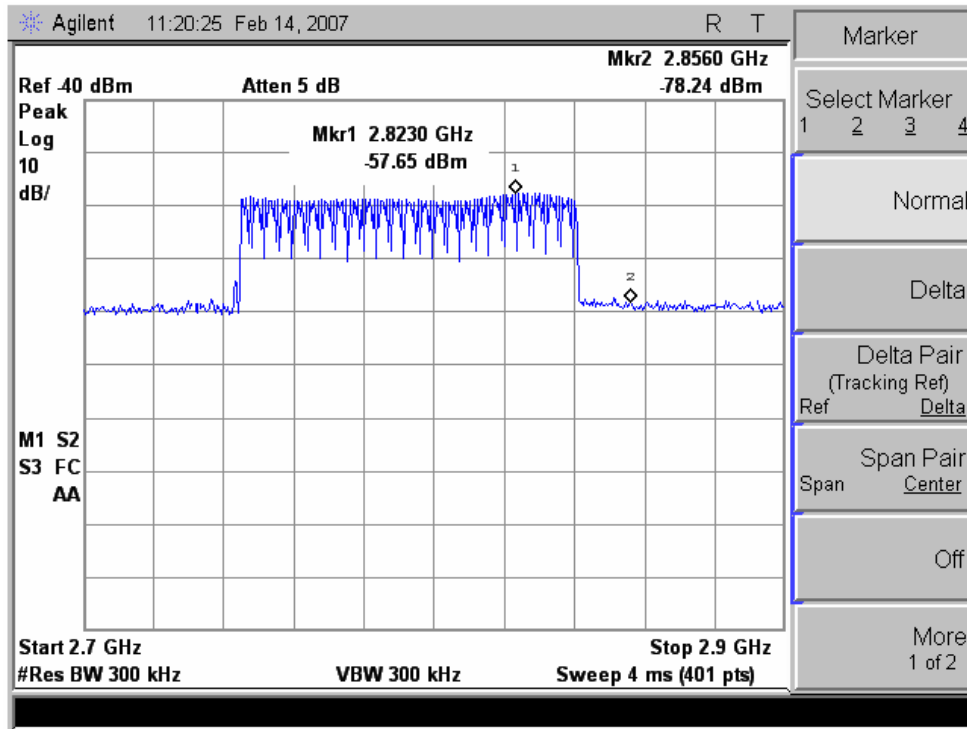

Figure 9. nRF24L01 Receiver LO leakage

## 4 Frequency accuracy

Through the TX carrier wave measurement you can also measure the frequency accuracy of the radio. Frequency accuracy is part of the telecommunication standards in some areas of the world (Japan and South Korea). But, the main reason for measuring frequency accuracy is to ensure a stable range performance in your application.

All radio devices have a specification on the output frequency error they can tolerate. In nRF devices the external crystal oscillator accuracy is the only contributing factor on frequency accuracy. This means frequency accuracy in nRF designs is directly linked to the crystal specification. Therefore, the frequency accuracy specification of a nRF device is given through a maximum part per million (ppm) offset requirement on the reference crystal.

**Note:** The crystal accuracy specification in nRF product specifications is the sum of absolute tolerance at 25 degrees celsius, temperature drift and aging in the crystal. These three points are usually separated in crystal data sheets.

Since the frequency accuracy of a nRF device is decided only by crystal reference frequency accuracy, measuring the frequency accuracy actually verifies that the external crystal circuitry design is correct.

### 4.1 Test method and setup

This test uses the single TX carrier test setup as described in [section 2.1 on page 5](#). Because this test is only concerned with frequency it can also be done over the air using antennas.

Once you have set up the HW and DUT, the most critical thing is to set the spectrum analyzer resolution bandwidth low enough to measure the frequency with sufficient accuracy. Sufficiently low Resolution Bandwidth (RBW) is essential to get a frequency measurement with good resolution.

Setting a RBW of 100 KHz on a spectrum analyzer means that the peak power can be found with a resolution of 100 kHz (+/-50 kHz). If we take as an example a 2.4GHz nRF device with a crystal accuracy specification of maximum +/- 30 ppm, the carrier on this device should not vary more than  $2.4\text{GHz} \times \pm 30\text{e-}6 \text{ ppm} = \pm 72 \text{ kHz}$ . This means that if you try to measure frequency accuracy on this +/-30 ppm radio with a RBW of 100kHz the accuracy in the measurement is heavily influenced by the accuracy of the spectrum analyzer reading, not the actual accuracy of the DUT.

Generally, a measurement accuracy 10 times the actual variation expected is a good guideline, so a RBW of maximum 10 kHz ( $2 \times 72\text{kHz} / 10 = 14.4 \text{ kHz}$ ) should be used to measure this parameter.

When you have set the measurement accuracy correctly it is easy to verify if the TX carrier is outside the accepted range.

Frequency accuracy is OK if:

$$\frac{|F_0 - F_{DUT}|}{F_{DUT}} \leq M \cdot 10^{-6}$$

Variable	Description
F <sub>0</sub>	Measured TX carrier frequency
F <sub>DUT</sub>	The frequency the DUT is configured to send (For example: 2.403 GHz)
M <sup>a</sup>	Absolute frequency tolerance of crystal at room temperature in ppm (For example: 20)

- a. M must be the absolute tolerance of the crystal at room temperature and not the total crystal accuracy requirement of the nRF device. This is because this measurement is conducted at room temperature and crystal frequency offset due to temperature drift should not be present.

Table 1. Frequency accuracy parameters

Figure 10. shows a crystal accuracy measurement on a nRF device with a +/-20ppm tolerance crystal programmed to 2.44GHz. The frequency offset is the difference between the center frequency (2.44GHz) and the marker frequency. The frequency offset in Figure 10. is 2.44Ghz-2.43999425 GHz = 5.75 kHz which is comfortably within the crystal accuracy (2.44GHz\* +/-20e-6 = +/-48.8kHz).

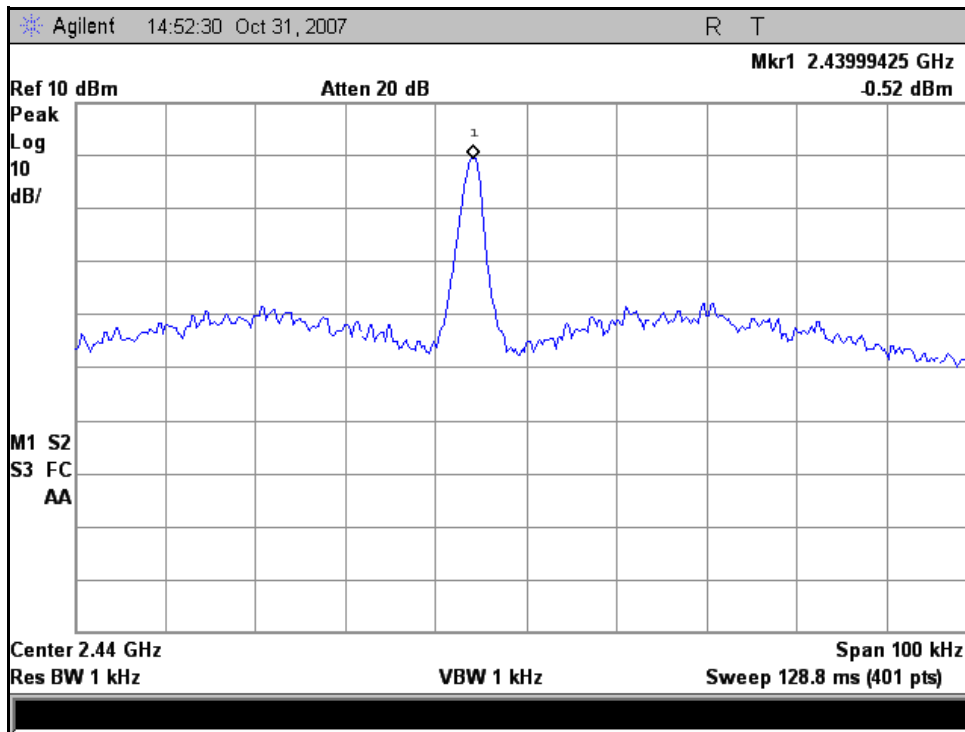

Figure 10. TX frequency accuracy measurement



---

If the measurement fulfills the frequency accuracy equation then your crystal oscillator circuitry is functioning as intended.

But, what is wrong if you measure a TX carrier frequency outside the window set by the equation?

- **Crystal accuracy:** The first issue to check is the accuracy specification of the crystal fitted. If this is too poor; replace it with a crystal that complies with our crystal specifications (available in the nRF product specifications).
- **Crystal load:** Wrong capacitive loading of the crystal also causes offsets in the TX frequency.

## 5 Modulation bandwidth

In the frequency bands where the nRF devices operate the modulation bandwidth is generally not regulated if all transmission power stays within the allocated band (2.400 – 2.4835 GHz in case of the 2.4GHz band).

There are two situations where it is important to verify the modulation bandwidth:

- Operation close to the edge of an allocated band (for example, close to 2.400 or 2.4835 GHz).
- If you add an external PA. In this situation the margin to the band edge must be increased and as the output power is increased all regulatory standards require that frequency spreading schemes like frequency hopping (FHSS) are used. The exact power level where these requirements take effect varies (FCC@ -1 dBm average ERP, ETSI/CE@10dBm ERP). The number of hopping positions that must be used in the FHSS scheme depends on the modulation bandwidth of the system. This means that the standards to follow are set by the modulation bandwidth.

### 5.1 Modulation bandwidth theory

To transfer data, a RF transmitter has to code the data it sends onto the pure carrier wave (explained in the previous chapters). All nRF devices use Gaussian Frequency Shift Keying (GFSK), a filtered version of basic Frequency Shift Keying (FSK). In FSK the logic level of the data sent is translated to a low and a high frequency as shown in [Figure 11](#). Varying the output frequency is called modulation.

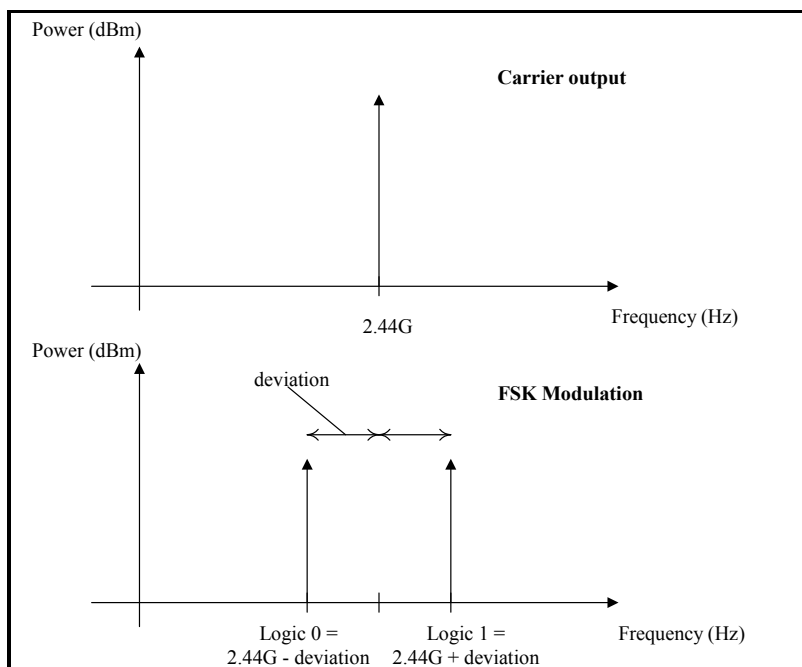

Figure 11. FSK modulation

A FSK transmitter never sends anything on the center frequency (given by the carrier frequency), only on the high and low frequency and which of these is used depends on the logic level of the incoming data. The offset from the center frequency to the frequency the FSK transmitter uses is called deviation.

The succession of changes between the high and low frequency creates a frequency spectrum called the transmit (TX) spectrum of the radio. If the modulation data changes with a periodical low rate the two FSK frequencies dominate the TX spectrum, see [Figure 12](#). This setup makes it easy to measure the deviation

of a nRF device (indicated by the markers in [Figure 12.](#)) and as shown, the bandwidth increases but the peak power level decreases compared to the pure carrier wave spectrum. This is because the carrier power is now spread over a wider frequency area called the modulation bandwidth.

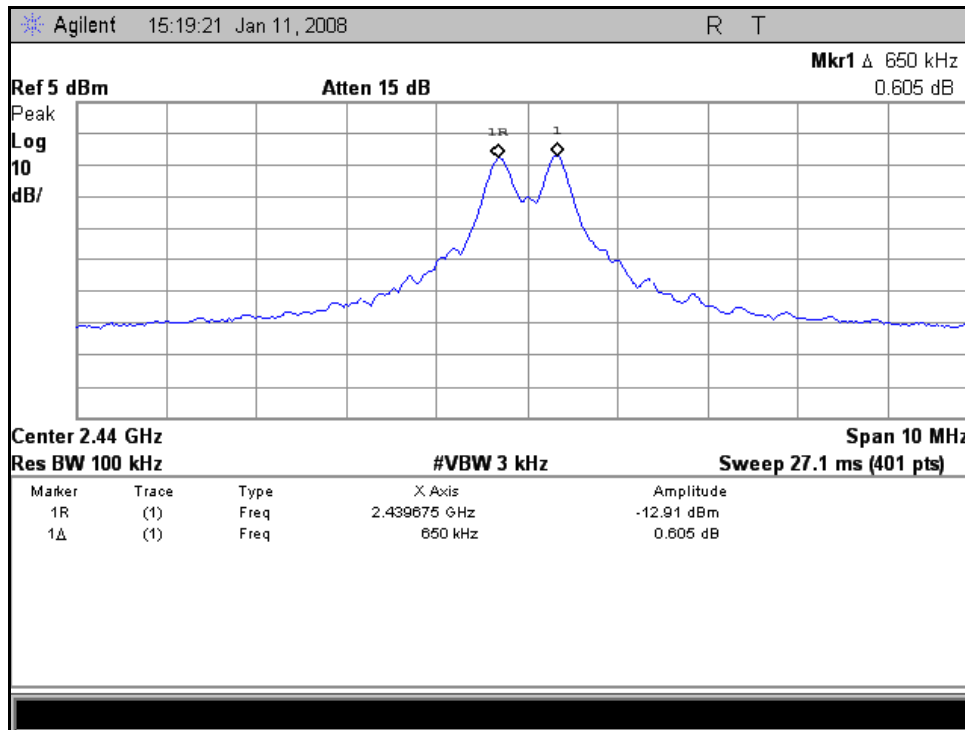

Figure 12. Spectrum showing nRF device deviation

The modulation bandwidth depends on the modulation type (for example, FSK or GFSK), deviation, data rate and the actual data sent. With a nRF device, modulation type and deviation are set by the chip design, so the spectrum in [Figure 12.](#) is of limited interest. What is interesting is the maximum modulation bandwidth of the radio in normal operation. To get a representative picture of the maximum modulation bandwidth on a specific data rate a Pseudo Random Bit Sequence (PRBS) should be used as actual payload data and the device should be set to send data packets as in a normal application. The PRBS sequence ensures an equal number of logic 0 and 1 in a random sequence is sent, mimicking the normal behavior of a transmitter.

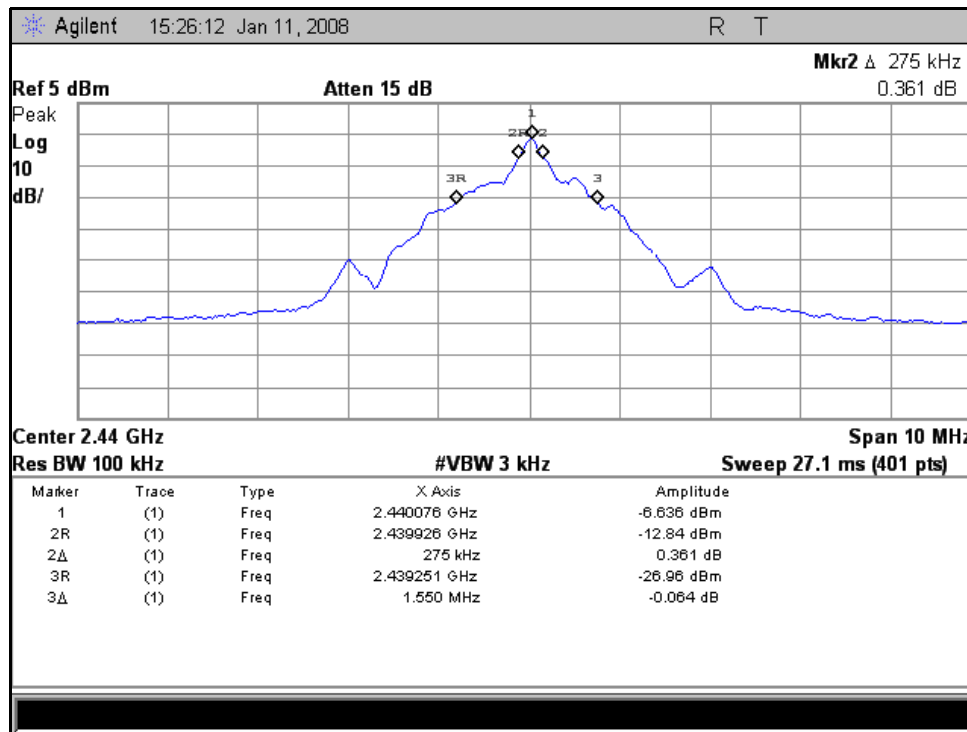

Figure 13. Modulated carrier bandwidth measurements

An example of the modulation bandwidth of a nRF device used in 2 Mbit/s mode is shown in [Figure 13](#). Both 6 dB and 20 dB bandwidths (BW) are commonly used to specify the width of this TX spectrum. The 6 dB bandwidth is, as indicated in [Figure 13](#), the frequency offset between a point (marker 2 and 2R) on each side of the spectrum that is 6 dB lower than the center of the spectrum indicated by the peak output power (marker 1). The 20 dB bandwidth is similarly the offset (marker 3 and 3R) between two points on each side of the spectrum, 20 dB below the peak output power.

A TX bandwidth specification does not mean that there is no power emitted outside this bandwidth. As can be seen in [Figure 13](#), the power in the TX spectrum rolls off outside the 20 dB bandwidth. This is a fact in all radio devices and the rate of the drop is mainly decided by the modulation type used in the RF device.

The 20 dB bandwidth of a transmitter is often denoted as the channel bandwidth of the system because this is the bandwidth the system needs for operating a channel of communication. The power emitted outside this bandwidth is emitted in channels next to the one in use and is called a neighbor channel emission, one of the parameters often specified in a device product specification. The neighbor channel emission shows you how much energy leaks out and can affect a second system operating on one of the neighboring channels.

The modulation bandwidth also impacts how close to the allowed band edges you can operate. All emission outside the frequency band you operate in (for example, 2.4GHz) is seen as spurious (unwanted) emission and must conform to the regulatory standards. [Figure 14](#) shows an example of a radio device set for operation at the lower band edge of the 2.4GHz band (2.400 GHz). This leads to a large amount of too powerful emissions below 2.400 GHz indicated by the shaded area in [Figure 14](#). At 2.400 GHz the out of band spurious limit of the regulatory standards comes into effect. For instance, the maximum spurious

emission limit in the regulatory standard for Europe (ETSI) is - 30 dBm. This means that all emissions in the shaded area (that is, everything between the markers) in [Figure 14](#), are illegal.

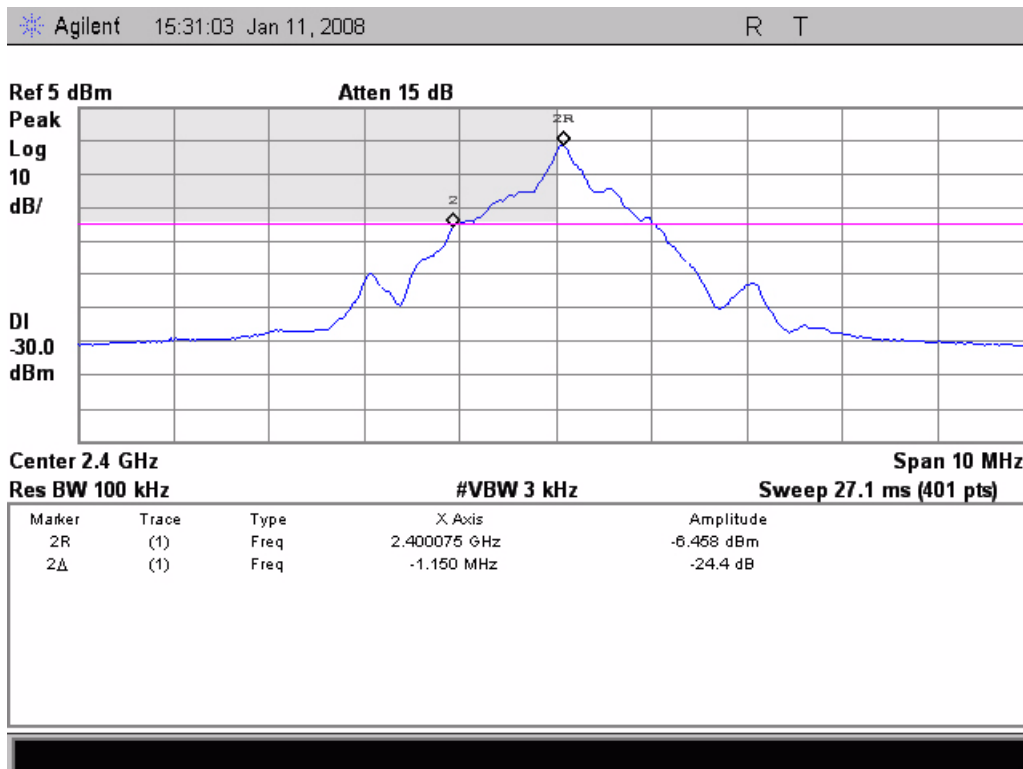

Figure 14. Emission limits at the band edge

This effect is called band edge spurious emission and is one of the main test criteria for regulatory RF emission standards approval. To comply with regulatory standards the lowest frequency this radio device can be set to is 2.402 GHz as shown in [Figure 15](#). It is visible from this figure that the output power at 2.400 GHz (marker 2) and below now has an ample margin to the limit at -30 dBm (marked by the red horizontal line).

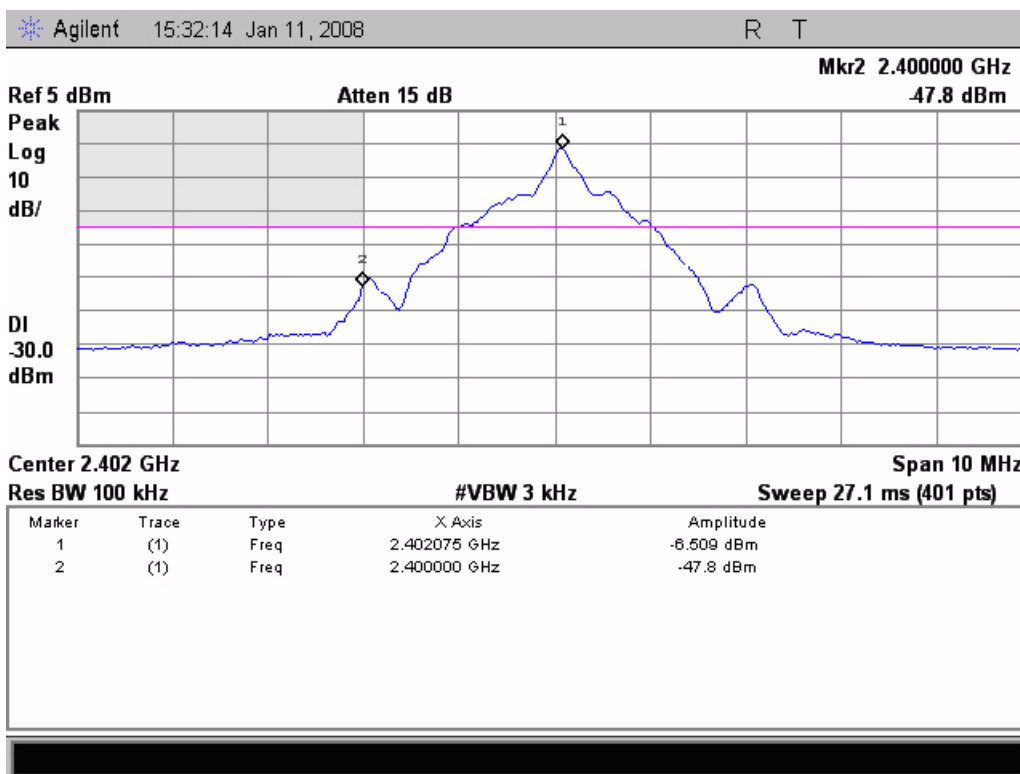

Figure 15. Emission complying with band edge spurious requirement

## 5.2 Test method and setup

The HW setup for this test is identical to the TX carrier wave setup.

You must set the Device Under Test (DUT) to send data, most nRF devices are optimized to send packets of data in short bursts. The payload of each packet should contain a PRBS sequence. How to set up a specific nRF device for this test can be found in the nRF performance test instructions for each nRF device.

The Spectrum analyzer setup is the same as for the TX carrier test:

- **Center frequency:** Equal to the RF frequency configured in the DUT.
- **Frequency span:** 1 - 10 MHz depending on the DUT.
- **Amplitude:** Must be set higher than the maximum output power capable of the DUT.
- **Resolution Bandwidth (RBW):** 30kHz- 300kHz depending on the frequency span used. In most cases simply setting the spectrum analyzer RBW to auto so that it follows the span is the best option.

Since all nRF devices are sending packets of information, the spectrum analyzer must be set to peak hold measurement and measure over several packets to capture the full TX spectrum. How long this takes depends on the processing speed of your spectrum analyzer.

The modulation bandwidth is found by adding the frequency markers as described in [Figure 13](#). Some spectrum analyzers can do this measurement automatically, to check if your spectrum analyzer can do this refer to its manual.

---

All nRF devices send packets in this test, this means the spectrum may not be as symmetrical as you expect. Since the measurement is done using peak hold, the measured spectrum also holds some frequency components originating from the frequency settling of the transmitter prior to the actual data modulation. This measurement gives the true picture of the TX spectrum of a nRF device in normal operation.

## 6 Receiver Sensitivity

The receiver sensitivity level is one of the vital receiver parameters that decides the maximum range you can achieve on a RF link. Measuring sensitivity in a receiver unit is very important since it not only relies on the nRF device, but also on the quality of the PCB design supporting the nRF device.

This section presents the terms related to receiver sensitivity and describes how radio devices are tested to find the receiver sensitivity numbers presented in the electrical specification tables in each device product specification.

### 6.1 Receiver sensitivity theory

Receiver sensitivity is the minimum input power level from the antenna that a radio receiver can handle without making a critical number of errors when decoding (demodulating) incoming data.

As the power received from your transmitter decreases ([Figure 16.](#)) with increasing physical distance between TX and RX, so does the margin between the incoming signal and the receiver's noise floor. The receiver noise floor is decided by the inherent noise found in all electrical circuitry. At a certain level this margin becomes too small for the receiver's demodulator to interpret the received data accurately leading to a sharp increase in the number of errors the receiver makes. The minimum margin between the receiver noise floor and the input power level where it can process an incoming signal properly is called the demodulator threshold. The noise floor level and demodulator threshold equals the sensitivity level of the receiver as shown in [Figure 16.](#)

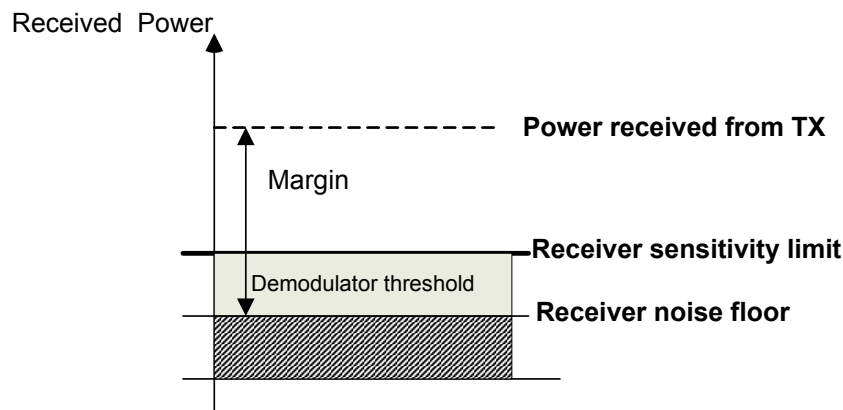

Figure 16. Receiver input power budget

The demodulator threshold depends on what modulation type is used, the noise floor is set by the bandwidth of the receiver and design trade offs (for example, current consumption in the receiver front end).

To design a radio with the best possible sensitivity you must minimize the bandwidth of the radio (less background noise received) and increase the current consumption in the receiver front end (less self generated noise). But, narrow receiver bandwidth limits the data rate you can achieve over the air and, for example, a too high current consumption in the receiver may render the radio unsuitable for battery applications.



Different radios have different sensitivity levels based on the trade offs made to make the radio the best overall solution for a set of end applications.

### 6.1.1 Bit Error Rate

Before measuring the RX sensitivity level, you must define poor receiver performance. As the received power drops towards and below the sensitivity limit, the average number of errors made by the receiver increases sharply. You must decide how many errors on average are acceptable to deem the receiver performance good. How many errors a receiver, on average, makes is given by the Bit Error Rate calculated by the following equation:

$$BER = \frac{\text{Number of errors made}}{\text{total number of bits received}}$$

A BER limit often used on low cost radios to define the sensitivity limit is  $10^{-3}$  or 0.1%. This means that if the input power is set at the sensitivity limit (for example -82 dBm) the receiver makes an average of 1 error for every 1000 bit it receives.

**Note:** This means that the radio does make a steady stream of errors when operating on the sensitivity limit.

Specifying sensitivity is always inter-connected with what bit error rate you are willing to accept and the data rate you operate on. Specifying a sensitivity limit without specifying the BER does not make sense. So, comparing the sensitivity limit of two receivers without making sure the BER level and data rate are set to the same, will lead to the wrong conclusions.

### 6.1.2 Sensitivity accuracy

To measure RX sensitivity with a good amount of accuracy you must first calculate the BER with a good enough accuracy. The noise that causes the receiver to fail at the sensitivity limit is stochastic (random), because of this the number of errors done by the receiver will also have a stochastic variation over time. You can see this effect in real life by the fact that when you measure the number of errors the receiver does over a given number of received bits, the number of errors will be slightly different for each test run. This of course also results in a slightly different BER for each test run. The only way to calculate a 100% accurate BER is to do an infinite number of test runs. This is, of course, not feasible, so when doing sensitivity measurements you must use statistical methods to set up a test that will give you an accurate BER.

Statistical measurements are aimed at measuring in a way that gives you a good confidence level. A confidence level of 99% means that you can be 99% sure that the number of errors found in one sample volume (one test run) are differing from the 'true' average number of errors (the mean found from an infinite number of test runs) with less than 3 times the variance ( $3 \cdot \sigma$ ). The  $\pm 3 \cdot \sigma$  interval is called the confidence interval.

The variance is a variable telling you how much the variable (number of errors) can differ from test run to test run. The variance takes on different characteristics depending on what kind of statistical distribution the variable you measure has. Since each error made by the receiver has the same probability, the statistical distribution of the number of errors in one sample volume will follow a Gaussian distribution. This is due to the central limit theorem. Due to these facts the variance in these tests will simply be the square root of the mean value of errors in a given sample volume.

In [Table 2 on page 26](#) you can see some examples of these relations for different sample volumes:

Total # of received bits (Sample volume)	Expected # of errors in sample volume (Mean)	99% Confidence interval (3*sigma)	Possible variation in # of erros on consecutive tests
10,000	10	+/- 9.5	+/- 95%
100,000	100	+/- 30	+/- 30%
1,000,000	1000	+/- 95	+/- 9.5%

*Table 2. Accuracy of BER measurement on different sample volumes*

Here you can see that if you plan to run a BER test with a total number of received bits of 10.000, the expected number of erros should be:

$$10000 \times 1e - 3 = 10$$

But due to the variance of the normal distribution:

$$SQRT(10) = 3.16$$

The only thing you can say with 99% confidence is that actual measured number of errors in each test run will be somewhere between:

$$\pm 3 * sigma = \pm 3 * 3.16 = \pm 9.5 \dots 0.5 - -19.5 errors$$

This means that you can get a variation in the number of errors on consecutive test runs of +/- 95%. Clearly establishing the BER from a sample volume of 10,000 received bits does not give you a very accurate result. But as you can see increasing the total number of received bits in each test run will give you ever better accuracy in the numbers you base the BER calculation on.

The next step is to decide how accurate the BER actually needs to be to give you a good measurement of the RX sensitivity. In [Figure 16](#), you can see a typical BER versus received RF power relation for a nRF device measured over a very large number of received bits. This is a very time consuming test but has good BER accuracy as a result.

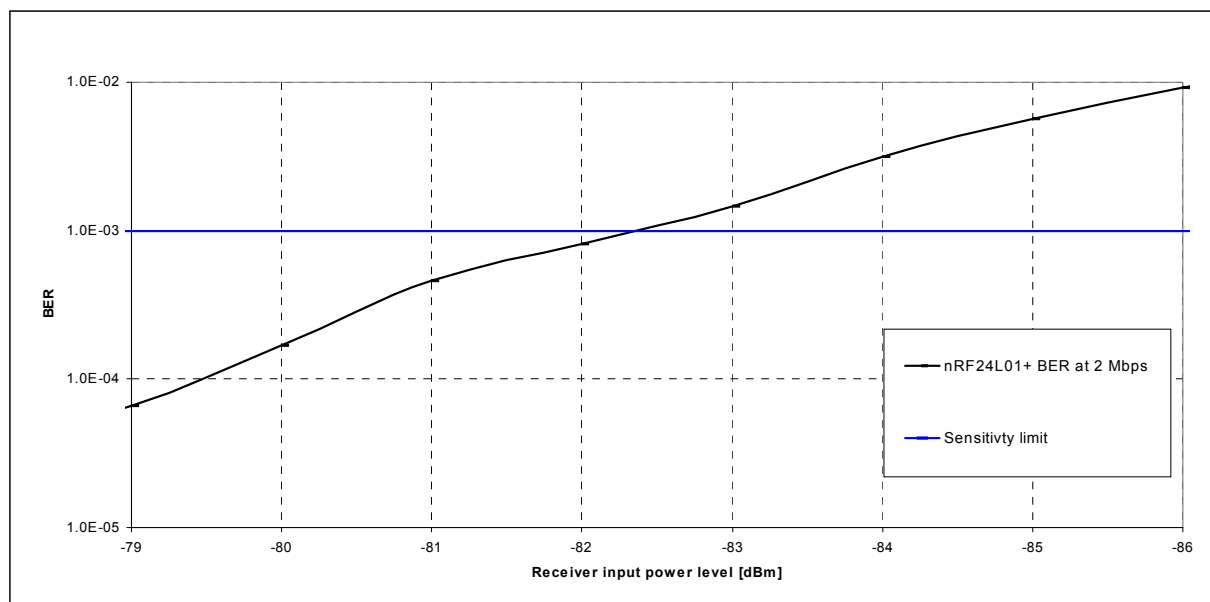

Figure 17. nRF24L01+ BER vs. RF input power

From this figure you can see that measuring the sensitivity limit of a nRF device (Example: -82 dBm for nRF24L01+@ 2 Mbps) with an accuracy of +/- 0.5 dB you must be able to accurately measure and calculate a BER between  $8e-4$  and  $1.4e-3$  or  $1e-3$  -20%/+40%, which we can approximate to  $1e-3$  +/-30%.

Referring back to [Table 2 on page 26](#), this gives us the conclusion that to measure the sensitivity limit of a nRF device with an accuracy of +/-0.5 dB, you must calculate the BER from the number of errors the receiver does in no less than 100.000 received bits.

### 6.1.3 What do sensitivity measurements tell you?

Sensitivity on all nRF devices is tested in our production. All our shipped devices comply with specified sensitivity levels in the nRF product specifications. But, in the final application, sensitivity is not decided only by the nRF device.

The deciding factor for actual sensitivity in your application is the incoming signal strength from the transmitter compared to the total noise level in the receiver. Any losses in the receiver signal path on the PCB (from antenna to the radio device antenna pins) or noise introduced from other PCB circuitry into the radio device degrades the sensitivity.

This means that measuring sensitivity on a nRF evaluation or development board enables you to verify our sensitivity limit specification, while measuring it on your own prototypes reveals the quality of your own PCB design. If your design or layout increases the losses in the RF path or level of noise in the RF circuitry, it will be seen as a degradation of the sensitivity limit.

**Note:** Optimal receiver performance can only be achieved if the PCB design is also optimal.

The reference layouts we provide address both these problems in the RF circuitry. The recommended antenna matches ensure minimal input loss when properly tuned. For details on antenna match tuning, please refer to [Tuning the nRF24xx matching network](#) white paper found on our web site. However, the total noise level on any given PCB is something that must be managed in each design through good circuit

design and layout (especially power supply and GND). Measuring sensitivity level on your prototype shows you if the noise level in your design is low enough. Use of GND planes and star routing of the power supply is essential for making the radio and other parts of the design perform at their best.

## 6.2 Test Method and Configuration

To measure sensitivity you must:

1. Apply a modulated RF signal that the receiver can demodulate.
2. Vary the power of this source in a controlled way.
3. Count the number of errors the receiver makes.

When conducting sensitivity measurements the receiver is tested on its performance limit. Low signal levels make this test the most demanding of all RF prototype tests. It is very important to control the test environment closely as any additional noise directly affects the measurement. Following the guidelines in [section 6.2.1](#) is essential. Also, putting the DUT into a shield box prevents neighboring RF systems affecting the stability of your measurements.

### 6.2.1 Test Setup

Always use cables when measuring sensitivity, using cables to measure is called conducted measurements. Any attempt to measure over the air, using antennas, is impossible because you no longer have exact knowledge of the power received by the DUT.

The test setup for a sensitivity measurement is shown in [Figure 18](#).

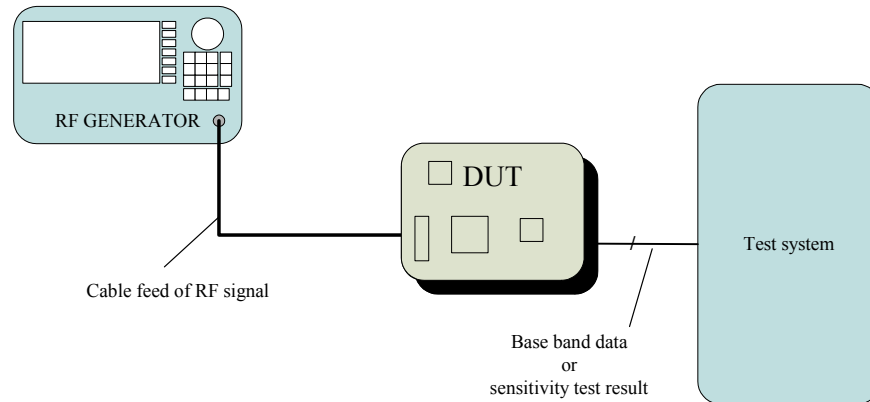

*Figure 18. Receive sensitivity level test setup*

To get a controlled RF input, use a RF signal generator to generate the input for the DUT. The required test routine is shown in [Figure 19](#).

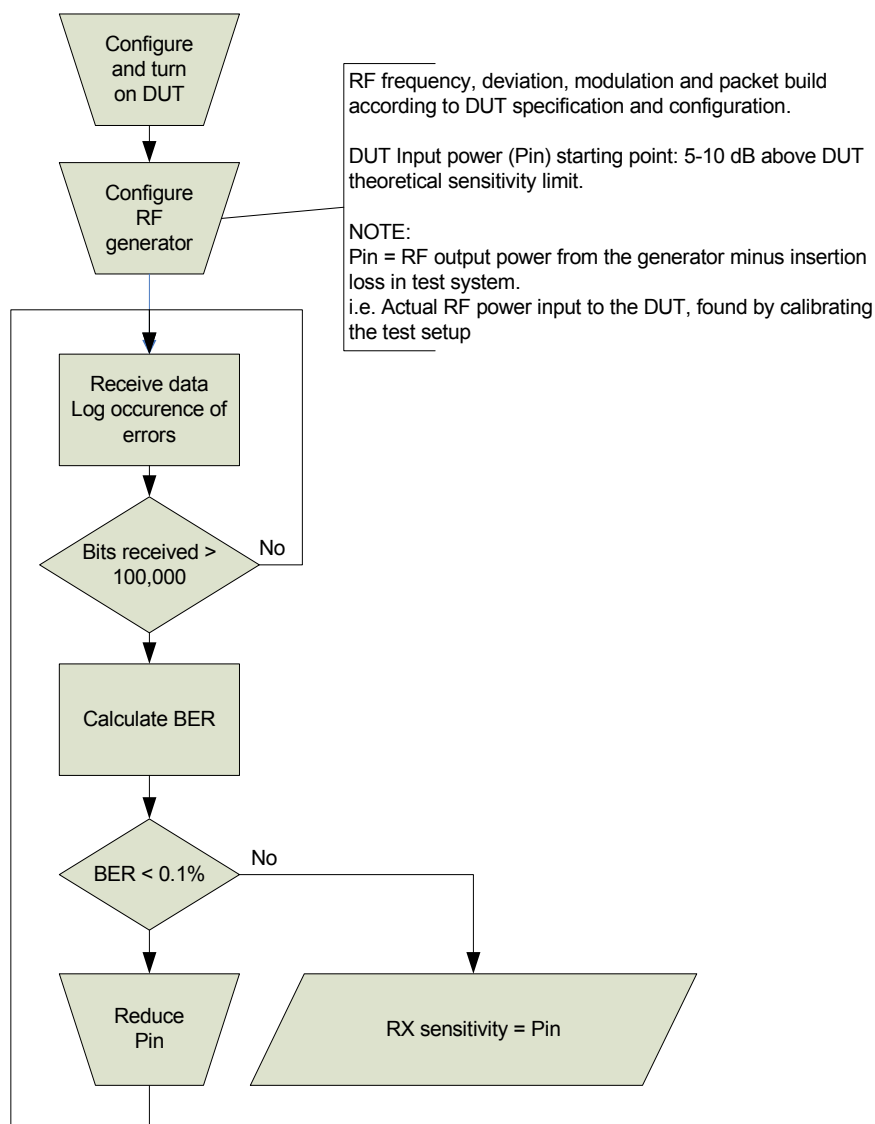

Figure 19. Receiver sensitivity test flowchart

RF generator frequency, modulation, deviation, data rate and possible data format (packet build with preamble, address and so on) are all decided by the DUT product specification. See details of the RF generator setup for specific nRF devices in the nRF performance test instructions for each nRF device.

On the base band side of the receiver you must have a system that can decide if the DUT has made an error. To do this the test system must compare the data sent from the RF source with the data output from the DUT. This can be done by feeding the modulation data from the RF generator to the test system which compares it to the DUT output while receiving. Alternatively, you can set a predefined data pattern (RF packets) in the RF generator to which the test system can compare the received data.

If you test by feeding the modulation data from the RF generator to the test system you need a RF generator that sends out the baseband data to the test system at the same time it sends data to the DUT. The test

system must also compensate for the different delays in the path directly from the RF generator and through the DUT. This is often done through auto correlation of two long sequences of data after the test is run. This requires a rather big and complex test system.

Instead, if you test using a predefined data pattern (data package), you run the same packet over and over again. The base band test system can be a simple microcontroller, preferably the one fitted to control the radio in your end application. This significantly reduces complexity. The payload you use should be a PRBS sequence. The results using this method are adequate for identifying noise problems in your design. How to make this sensitivity measurement test firmware on a simple MCU is described for each nRF device in the nRF performance test instructions.

**Note:** Using off the shelf BER testers is not always straightforward because they generally are made to test devices running on open standard protocol, such as Bluetooth, and key RF parameters usually differ from nRF proprietary ones.

### 6.2.2 Calibration of measurements

RF generator output power is the varying input parameter in the test. Remember that losses in the coax cable and connectors must be subtracted from the power level indicated on the RF generator to get the true power level applied to the DUT.

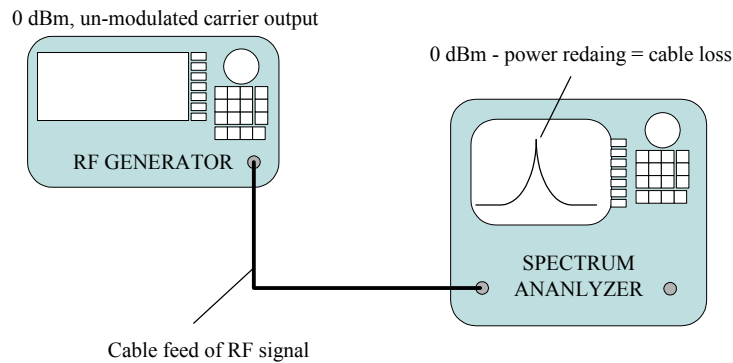

Figure 20. Calibrating DUT power input

The insertion loss from the RF generator to the input of the DUT can be measured by sending a carrier of, for instance, 0 dBm from the RF generator and measuring the actual power level at the DUT input with a spectrum analyzer. 0 dBm is far from the level you are going to use in the sensitivity test, but these levels (-80 to -100 dBm) are very difficult to measure on the spectrum analyzer, so a higher level is usually needed. To add accuracy to the calibration you can also measure the RF generator level on lower output power levels to verify that the linearity of the RF generator output is good, that is, that setting the RF generator to 0 dBm equals 0 dBm output, and setting it to -50 dBm equals -50 dBm output, and so on. For details on spectrum analyzer setup refer to [Section 2.1 on page 5](#).

### 6.2.3 Low cost set up

If you do not have a RF generator you can get an approximate level of the sensitivity limit through the set up shown in [Figure 21](#).

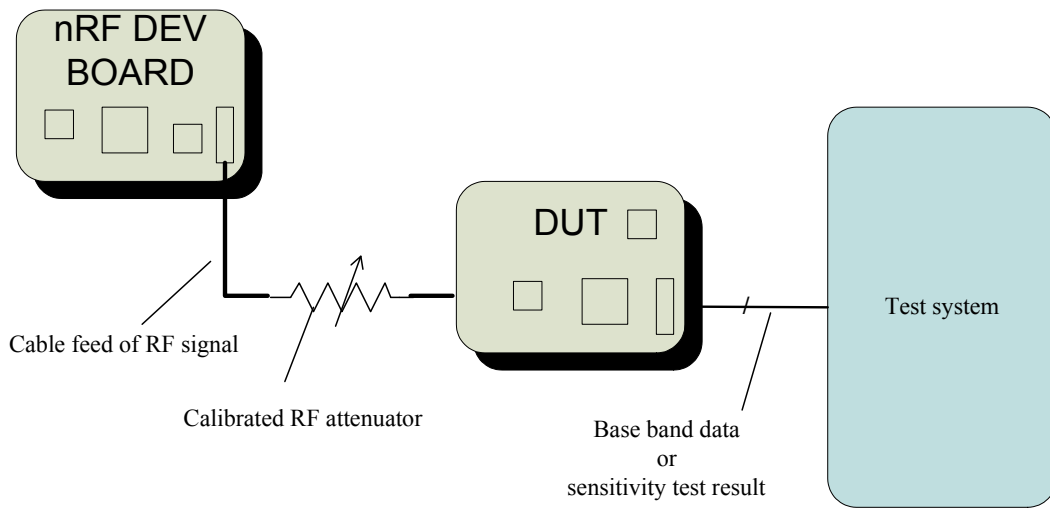

Figure 21. Low cost set up with nRF development board

In this set up you use a Nordic Semiconductor development board as a signal source and a RF attenuator to control your input power. The input power of the DUT must be verified using a spectrum analyzer. The rest of the test routine is as described in [Figure 19](#).

**Note:** The measurement of the input power at the low levels will not be as accurate as the test setup using a calibrated RF generator.

## 7 Receiver selectivity

Receiver selectivity quantifies how a RF receiver performs when subjected to unwanted radiation (interference) from other RF systems operating either on the same frequency (co-channel) or frequencies close (adjacent channel) to your operating channel.

The selectivity in nRF devices is fully controlled by the chip design which means this test can only be used to verify the selectivity numbers given in different nRF device product specifications. Performing the following complex test will not give you any information that can improve your PCB design. Receiver selectivity is included to show how the selectivity parameters found in nRF product specifications are measured.

**Note:** Receiver selectivity is generally not part of governmental regulations and consequently not critical for getting a nRF design approved for sale.

### 7.1 Theory

Receiver selectivity specifies how much input power from an interfering/unwanted system the receiver can handle while still receiving a signal from its own wanted transmitter. The receiver's ability to reject input signals from other systems is also commonly called co-channel rejection and adjacent channel rejection. The ability of the receiver to reject power from unwanted transmitters operating on frequencies more than 2-3 channels away is called blocking or wideband blocking.

The RF channel is defined as the bandwidth (BW) that the radio under test requires for communication. The first adjacent (neighboring) channel is one bandwidth offset from the frequency used by the radio under test, the second is  $2 \times BW$  offset and so on. This is illustrated in [Figure 22](#).

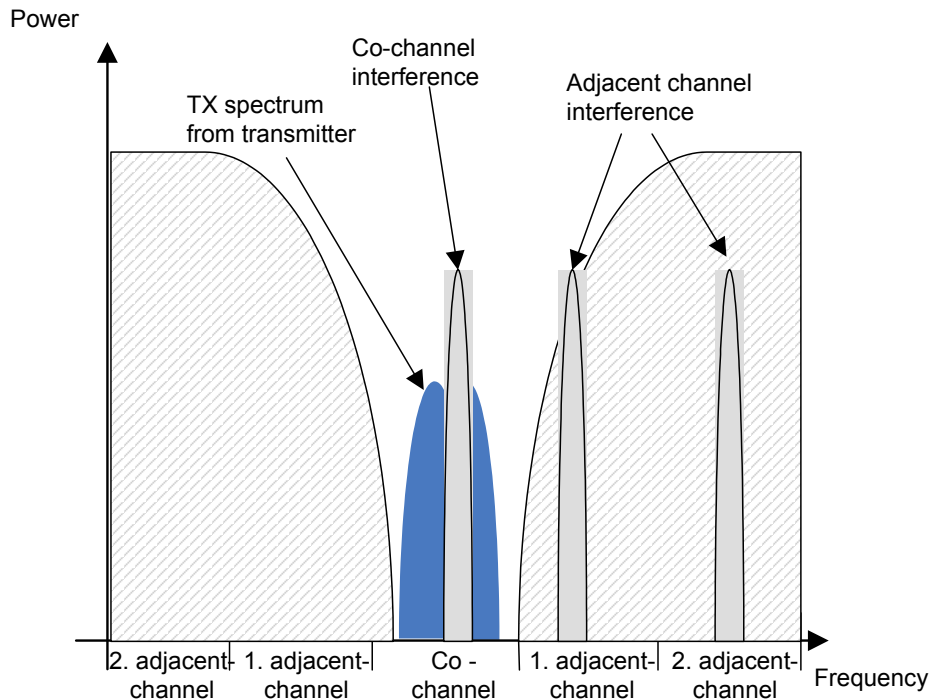

Figure 22. Co and adjacent channel interference

Receiver selectivity is indicated by the shaded area in [Figure 22](#).



If the input power received from an interfering system exceeds the selectivity of the receiver then the interference causes the receiver to make errors and you have an increase in the Bit Error Rate (BER). [Figure 22](#) shows how a received interference signal with a certain power level may affect your receiver if it is the co-channel or 1st adjacent channel interference, while it is no problem if it is found in the 2nd adjacent channel or further away.

## 7.2 Test Method and Configuration

### 7.2.1 Test Setup

To measure RX selectivity you must apply the wanted RX input signal and an interfering signal at the same time.

When measuring receiver selectivity, the test environment must be closely controlled. This is only achieved by using cables between the transmitter, noise source and receiver (conducted measurement) instead of antennas. Using antennas is not reliable because of multipath fading effects, constructive and destructive interference and unpredictable signal levels. This is why conducted measurements are the only way to conduct precise receiver parameter tests.

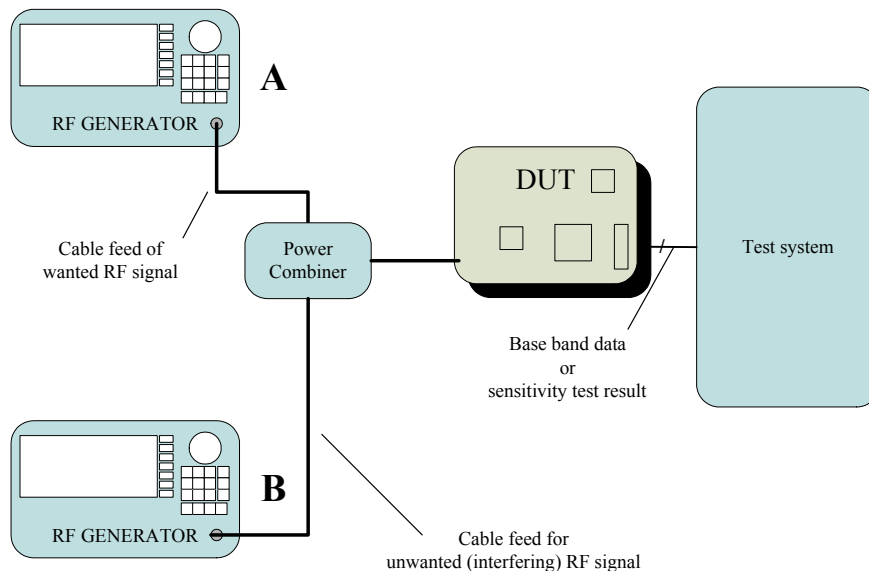

Figure 23. RX selectivity test setup

[Figure 23](#) shows the required hardware test setup. Signal generator A generates the wanted input signal for the Device Under Test (DUT). Signal generator B acts as the interference source. The power from the two generators is then combined and applied to the DUT.

See nRF performance test instructions for each nRF device for details on instrument set up.

RX selectivity test is based on the same core routine as the RX sensitivity test but, with the interference from generator B being the variable input. The test routine for finding RX selectivity is shown in [Figure 24.](#)

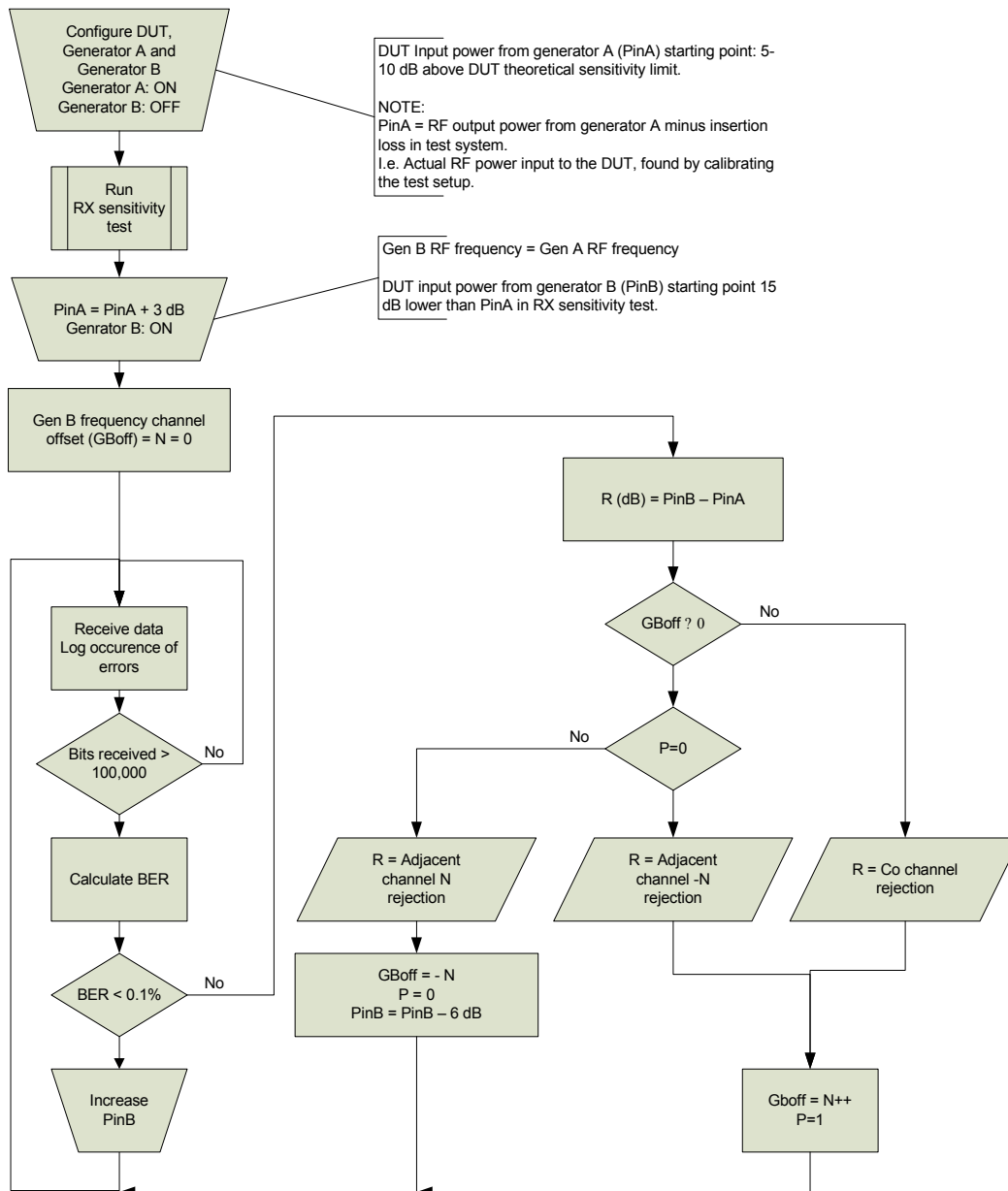

Figure 24. RX selectivity test flowchart

In the RX selectivity test the sensitivity of the DUT is first established and a 'wanted' input signal is applied slightly (3 dB) above this. Then the RX performance of the DUT is measured with generator B applying noise on co- and adjacent channels. How many channels (how big N can be) depends on how much information you want and how much time you have to do the test. Usually in product specifications numbers for up to 3 adjacent channels are used giving  $N < +/-3$ . The wanted signal generator is set to send the same information as in the RX sensitivity test, but at a power level 3 dB above the sensitivity limit found in the RX sensitivity test. As long as RF generator B is off, the DUT should make no errors receiving the signal from generator A.

The RX selectivity data can be presented in two ways:

- Receiver selectivity: PinA – PinB.
- Receiver noise rejection: PinB – PinA.

The only different results are the polarity of the numbers presented in device product specifications.

## 7.2.2 Calibration of measurements

To calibrate this test setup use the same routine that is used for the sensitivity measurements (see [chapter 6](#)). With the power combiner, the insertion loss between the RF generators and the DUT increases. The insertion losses from each RF generator must be measured separately, but with both generators connected. [Figure 25](#) shows the setup used to find the insertion loss from generator A. The difference between the RF output power set on generator A and what you read on the spectrum analyzer informs you of how much the wanted signal level (that is, RF generator A output power) must be increased in order to apply a power of PinA on the DUT. Repeat the measurement with generator A OFF and B on, this reading informs you of how much you must add to the RF power setting of generator B to get a correct level of PinB.

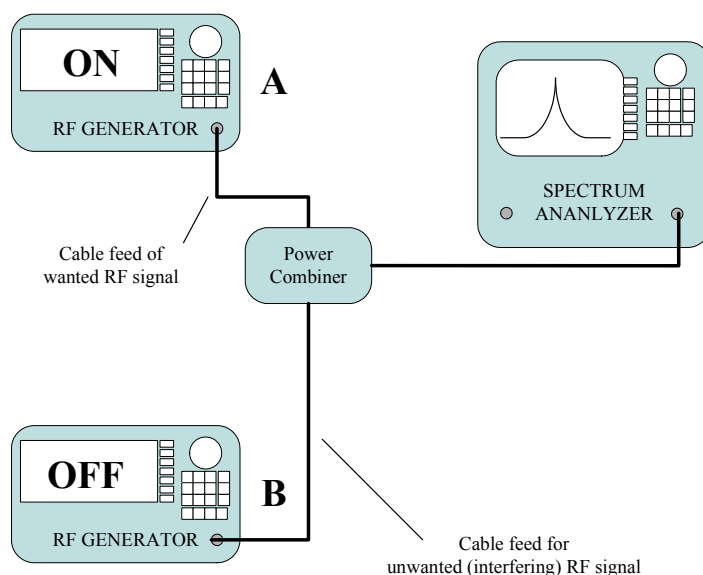

Figure 25. Insertion loss test set up

## 7.3 Types of interference

Radio devices are exposed to several kinds of interference sources. To compare with other receivers, the nRF devices product specifications have two types of interference listed.

As defined in European regulation ETSI EN 300 440-1 V1.3.1 (2001-09):

- Interfering source is an unmodulated carrier in the center of each channel (Chapter 8.2)
  - This gives a selectivity number purely for comparison with different receivers.

As defined in Bluetooth Core Ver. 2.0:

- Interfering source is a modulated signal similar to the one used by the DUT itself (Ch.4.1.2)
  - This gives a more realistic picture of how several units of the same radio manage.

## 8 Current consumption

Current consumption is one of the main design parameters in any electronic design. It is important, especially in battery operated applications, to keep current consumption tightly controlled. Current consumption calculations form the basis for your choice of power supply circuitry, battery technology and estimating battery lifetime.

This section presents the method and test setup for accurate measurements of the current consumption (static, average and dynamic) in nRF devices. It also describes how you can use these measurements to find average current consumption in the radio and how you can use it to estimate battery lifetime.

### 8.1 Static and average current consumption

The simplest approach to measuring current consumption is to use a standard ampere meter. Using an ampere meter or multimeter with the nRF device, as shown in [Figure 26.](#), makes measuring the current consumption of a nRF device while it is in a steady state straightforward.

The following points are important for measuring static current consumption accurately:

- Ensure that your measurement setup isolates the current drawn by the nRF device, that is, put it on a VDD branch supplying only the nRF device.
- Ensure that the nRF device is in a steady state. All nRF devices contain HW link layer protocol engines (ShockBurst™ engines), which means that they return to standby as soon as they have finished a task. The most convenient time to measure the current consumption stated in nRF product specifications is during the tests described in this document.
  - TX current consumption: while running any of the TX tests
  - RX current consumption: during the sensitivity test (or normal operation)

In power saving modes the current consumption can be measured at any time but be aware of the accuracy requirements on these tests. High accuracy ampere meters or multi-meters are required to measure in these modes. The current consumption of nRF devices is usually  $\ll 100 \mu\text{A}$  in standby and  $< 1 \mu\text{A}$  in power down.

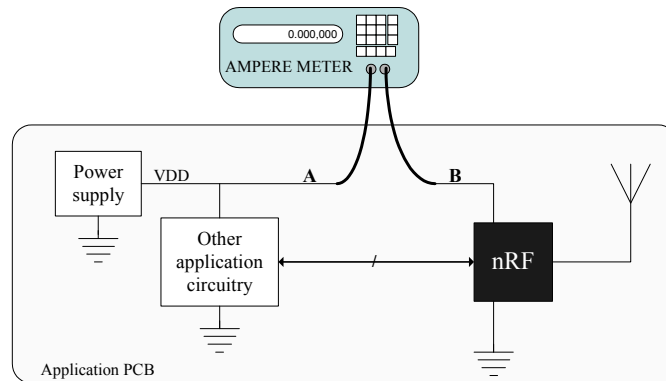

Figure 26. Power down and standby current consumption HW setup

If your ampere meter can also take RMS readings, you can monitor the average current consumption drawn by the nRF device in normal operation, that is, running communication and changing between TX, RX and power saving modes. All ampere meters rely on a shunt resistor and the current is converted to a voltage drop that can be measured. This voltage drop decreases the voltage supplied to the radio device. A typical high accuracy, low current ampere meter has a 5 ohm shunt resistor. You must check the speci-

caution for the ampere meter used and make sure this shunt resistor does not cause a too high voltage drop.

If the application has a very low duty cycle (spends little time in active mode), measuring average current consumption with an ampere meter gives you little or no information, especially if you find that your average current consumption is not as expected. There is another way to measure the dynamic current consumption in a nRF device which is described in the following sections.

## 8.2 Dynamic current consumption

Measuring dynamic current consumption gives you accurate numbers on the current consumption in a nRF device as it switches between different modes. Based on these measurements you can calculate the average current consumption based on measured values. Dynamic current consumption measurements can also be a good tool if you find that unexpected currents are drawn. Even if you have a logical error in your design (it does not do what was expected) a dynamic current consumption test shows clearly which modes the nRF device enters and when it enters them. There are two main challenges when measuring the dynamic current consumption of radio devices:

- Transient current consumption measurements are needed to accurately capture peak current levels when radio devices are in active (TX or RX) mode. All radio devices utilize hardware protocol engines (ShockBurst™) and high data rate to minimize the time used to transfer data. This means short bursts of high and low levels of current consumption. Capturing the peak current levels in different modes is a task that normal ampere meters cannot do.
- High accuracy measurements when radio devices are in standby or power down. High accuracy ampere meters are needed, but how accurate and what should you look out for if the measurements are not as expected?

### 8.2.1 Test method and HW setup active current consumption

Because of the transient nature of a radio device sending packets, an oscilloscope must be used to measure the voltage drop over a small test resistor put in series with the radio device power supply. On most modern (digital) oscilloscopes you can use mathematics on the measured wave forms and then use this to show the current consumption. See [Figure 27](#), for this type of test setup.

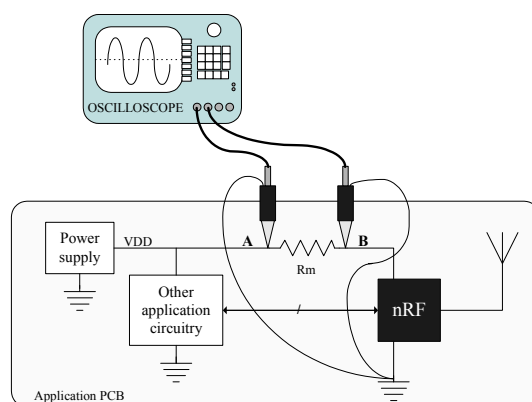

Figure 27. Radio active current consumption measurement

The two probes from the oscilloscope measure the voltage on each side of a test resistor  $R_m$ . The current drawn by the radio device gives rise to a voltage drop in the resistor and the difference between the voltage in point A and B gives the following current consumption:

$$I = \frac{V_A - V_B}{R_m}$$

With the mathematics option on the oscilloscope, Channel A minus Channel B ( $V_A - V_B$ ) can be shown on the oscilloscope screen directly. The value read when divided with  $R_m$  gives you the instantaneous current consumption of the radio device.

The value of  $R_m$  should be in the range of 1 to 10 ohms. A larger resistor gives you a larger voltage drop over the resistor, but a larger resistor also increases the VDD ripple (noise) in the RF device. A large resistor together with the de-coupling capacitors on the RF device will form a low pass filter and smooth the transition to current out, making the measurement difficult to read. To ensure good RF performance the power supply noise should be kept under 50 mVpp. Power supply ripple on the radio device is verified by measuring the voltage in point B.

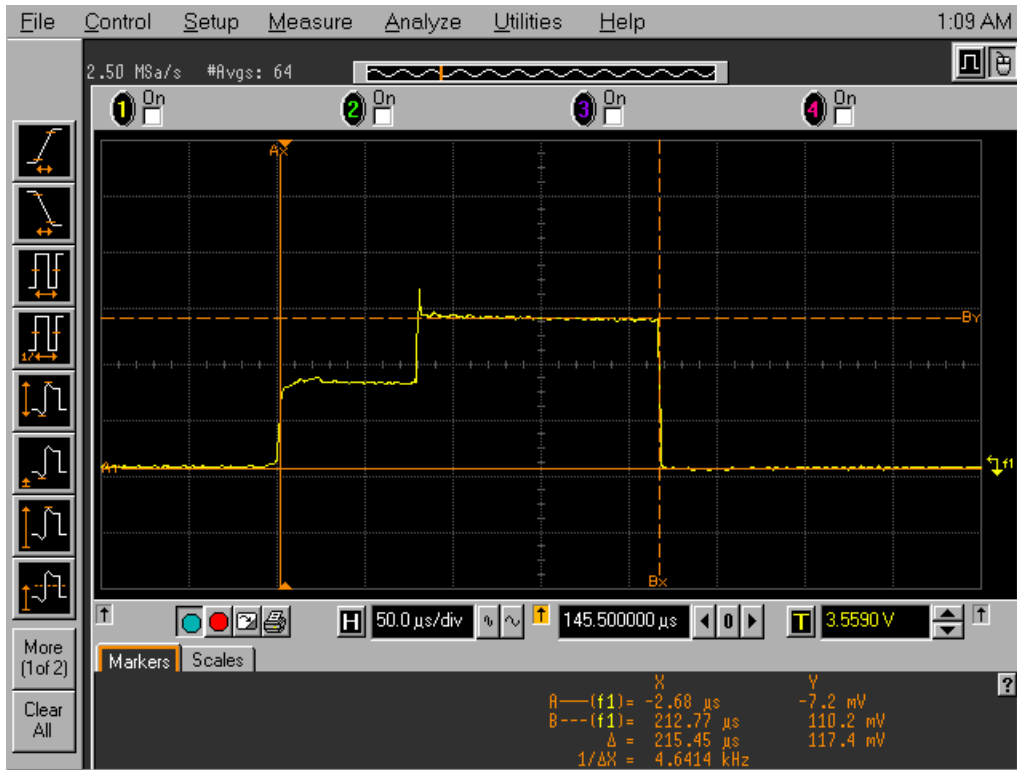

Figure 28. nRF24L01 transient current consumption measurement

Figure 28. shows an example of the current consumption variation during a transmission of a packet using nRF24L01. Initially, the device is in standby and the current consumption is low. From marker AX it increases the current drawn as it powers up internal modules preparing to send data. At  $t = 80 \mu s$  the final modules (the PA) are powered up and the device consumes the peak TX current set in the device product specification. After the final modules have stabilized (nRF24L01:  $t=130\mu s$ ) the actual packet is sent (no change in current consumption). When sending the packet is finished the device automatically returns to standby at  $t=215 \mu s$ .

**Note:** To capture these transient changes in the DUT current consumption, it is vital that  $R_m$  is placed as close to the device as possible.

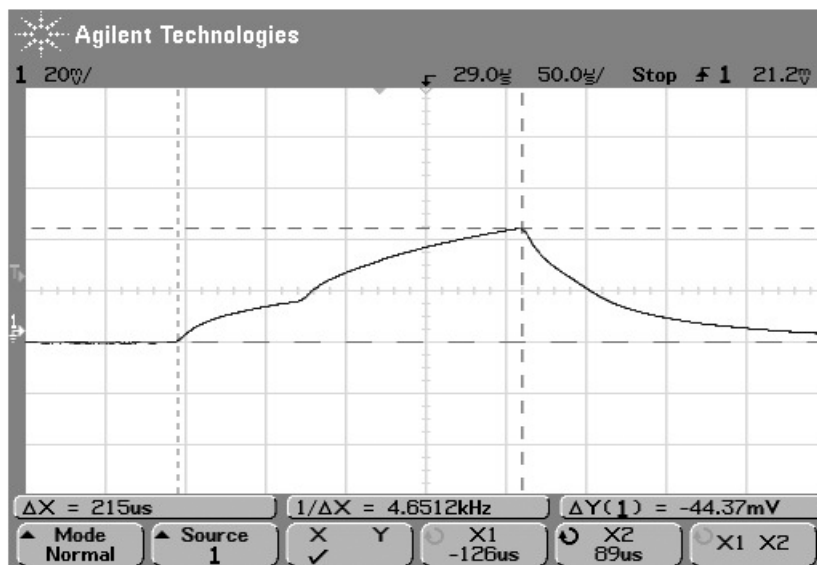

Figure 29. Transient current consumption measurement filtered

Any routing and de-coupling capacitors between  $R_m$  and the DUT act as a low pass filter and affect the measurement. [Figure 29](#) shows how the transient current consumption output may look if you have too much filtering between  $R_m$  and the DUT. All the transient edges are smoothed out and it is impossible to measure the exact current consumption in the different modes.

If you do not have an oscilloscope with a mathematic option you can do the same measurement with the set up in [Figure 30](#). In this way the  $V_A - V_B$  voltage is shown directly on the oscilloscope screen.

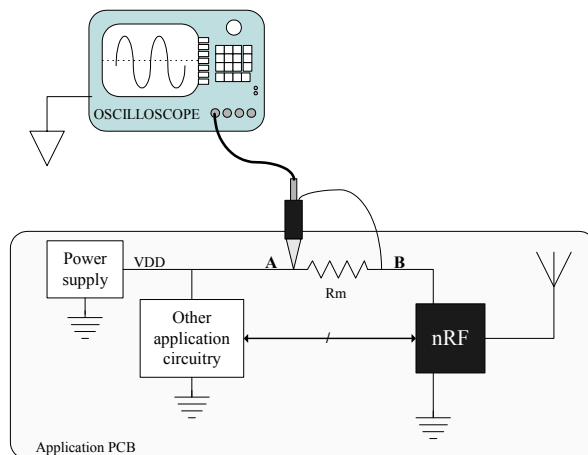

Figure 30. An alternate way to measure current consumption

Now the GND reference of the oscilloscope is no longer the same as the GND in the application. Point B in [Figure 30](#) is an oscilloscope GND reference and is separated from the application VDD by  $R_m$ . If your application is mains supplied, ensure that the GND of the oscilloscope is isolated from the GND of your application. If you do not do this massive currents may flow from your power supply through  $R_m$  and the oscilloscope to GND.

**Warning:** This can destroy the power supply in your application and can also be harmful to the oscilloscope.

This isolation is achieved by putting an isolating transformer in series on the oscilloscope mains supply. Isolating transformers can be bought from a number of sources that provide transformers and laboratory power supplies.

### 8.3 Calculation of average current consumption

If you have an application with a fixed report rate, the average current consumption in a radio circuit can be calculated from this measurement using the following formula:

$$I_{AV} = \frac{\sum_n I_{peak_n} \cdot t_n}{\sum_n t_n}$$

As an example let us look at the TX current consumption measured in [Figure 28](#). Let us assume that the device sends a packet like this every 10 ms and stays in standby using 20 uA between each packet. The overall average current consumption can then be calculated by finding the average current consumption over one of the 10 ms periods. The below equation assumes that the current has peaked from the start of the packet transmission:

$$\begin{aligned}
 I_{AV} &= \frac{\sum_n I_{peak_n} \cdot t_n}{\sum_n t_n} = \frac{\frac{V_A - V_B}{Rm} \cdot t_{burst} + I_{standby} \cdot t_{standby}}{t_{burst} + t_{standby}} \\
 &= \frac{11,7mA \cdot 0,215ms + 0,02mA \cdot 9,785ms}{10ms} = 0,27mA
 \end{aligned}$$



## 9 Glossary of Terms

Term	Description
BER	Bit Error Rate: The number of errors a receiver makes.
Conducted measurements	Using cables to conduct all output power measurements on a radio device.
DUT	Device Under Test
FSK	Frequency Shift Keying
Insertion loss	Loss of some power from the DUT in the test cables and connectors. Occurs when working on high frequency systems.

*Table 3. Glossary*