

# NLAS7242MUGEVB

## NLAS7242 High-Speed USB 2.0 (480 Mbps) DPDT Switch Evaluation Board User's Manual



ON Semiconductor®

<http://onsemi.com>

### EVAL BOARD USER'S MANUAL

#### INTRODUCTION

This evaluation board has been designed for a quick evaluation of the NLAS7242. The NLAS7242 is a 2-to-1 analog switch designed for USB 2.0 signals, as shown in the block diagram in Figure 1 on the right. Among its main characteristics, this evaluation board has been constructed to easily interface with a customer's systems and equipment through USB connectors. The evaluation board can be seen in Figure 2 below.

This manual provides a bill of materials, board schematic, and a layout overview of the evaluation board. The appropriate setup to evaluate the device is also provided.

This document must be used with the NLAS7242 datasheet available on [www.onsemi.com](http://www.onsemi.com). The datasheet contains full technical details about the specifications and operation of the device. When the intention is to evaluate the device considering the specifications given in the datasheet, it is important to take into account the additional circuitry which may include changes in the characteristic impedance matching.

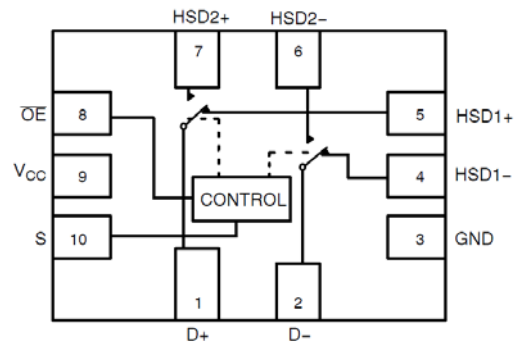

Figure 1. Block Diagram of NLAS7242

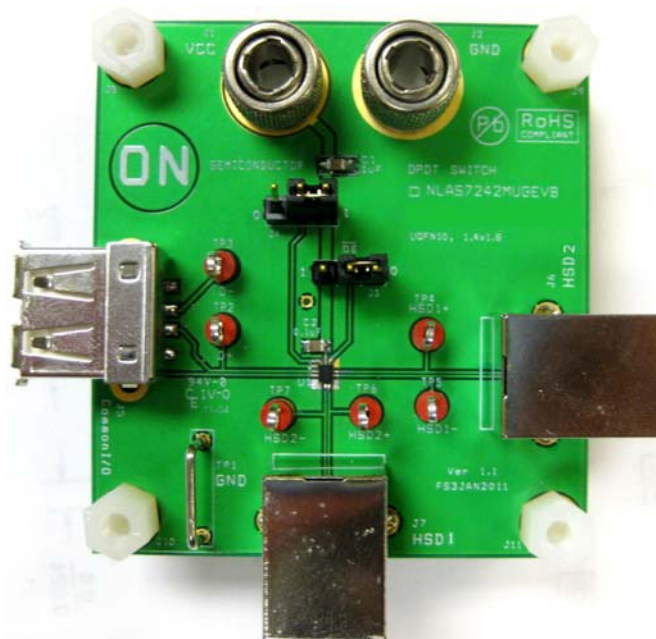

Figure 2. Evaluation Board

# NLAS7242MUGEVB

## GET STARTED

### Equipment

- DC Power Supply
- 2 Banana Cables
- Computer with USB port
- USB Flash Drive
- USB Cable (Type A to Type B)

### Procedure

1. Set the power supply to 3.3 V. Connect the power supply from **VCC** to **GND** using the banana cables. The supply current should be less than 1  $\mu$ A.
2. Connect the USB drive to the **Common I/O** USB port.

3. Select the desired output port (**HSD1** or **HSD2**) by moving the jumpers to the appropriate logic level for **S** and **OE**, as shown in the function table in Table 1.
4. Connect the USB cable from the desired output port (**HSD1** or **HSD2**) to the computer's USB port. You will now be able to access the USB drive through the computer.

Table 1. FUNCTION TABLE

OE	S	HSD1+, HSD1-	HSD2+, HSD2-
1	X	OFF	OFF
0	0	ON	OFF
0	1	OFF	ON

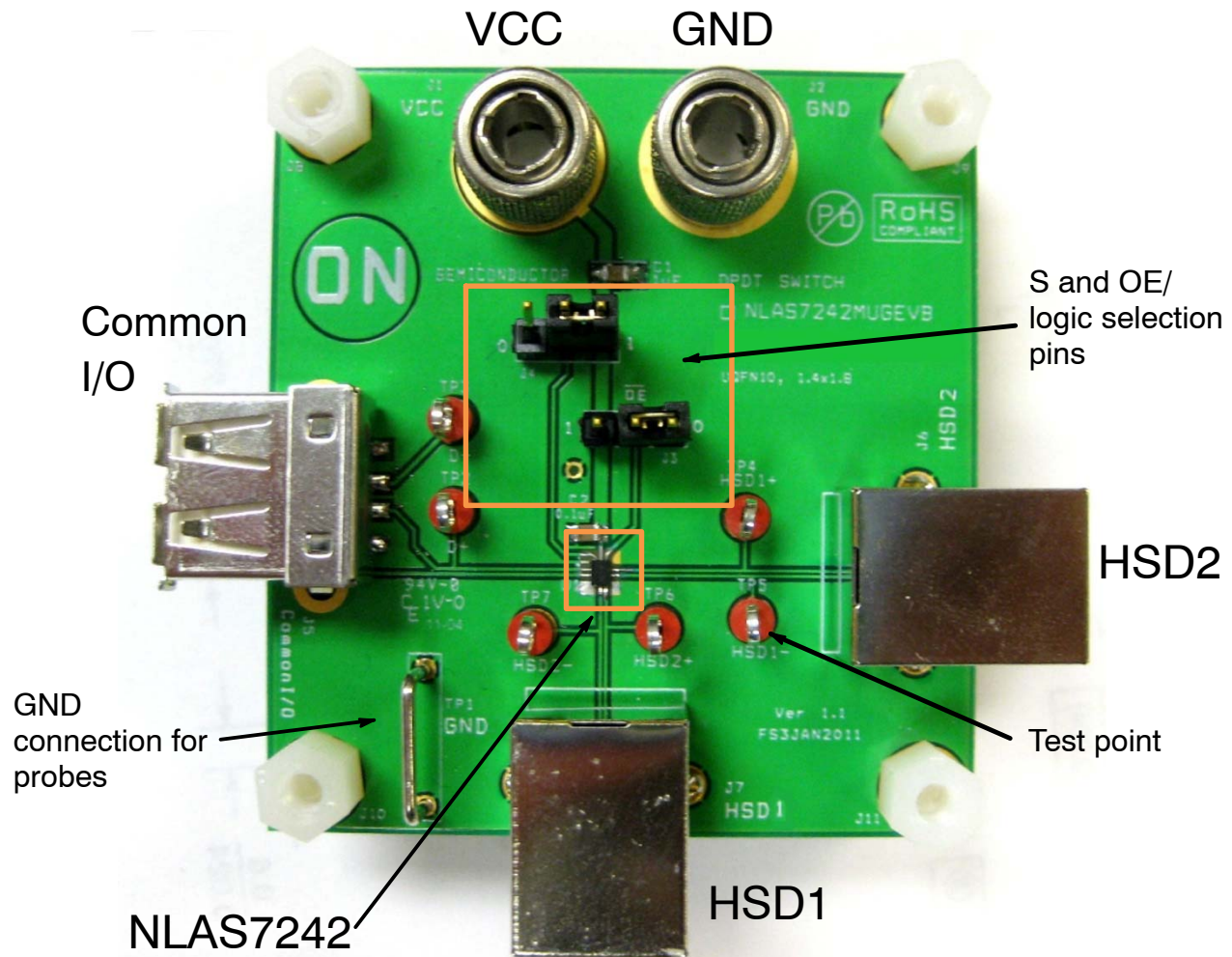

Figure 3. Demo Board Close-Up

# NLAS7242MUGEVB

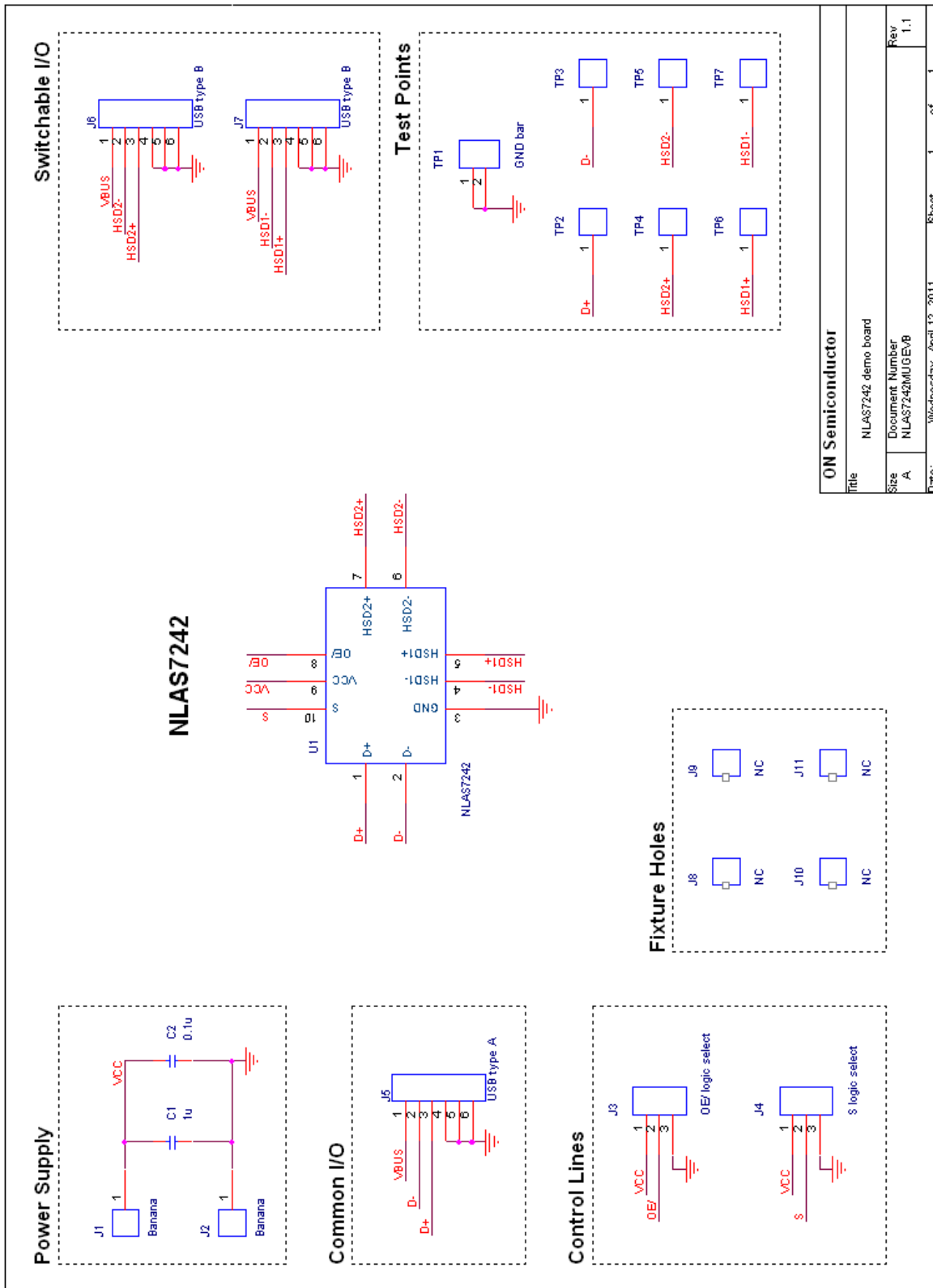

Figure 4. Schematic

## NLAS7242MUGEVB

**Table 2. BILL OF MATERIALS**

Designator	Qty	Description	Value	Tolerance	Footprint	Manufacturer	Manufacturer Part Number
C1	1	Ceramic Capacitor SMD	1 $\mu$ F	10%	0805	AVX	GRM155R60J105
C2	1	Ceramic Capacitor SMD	0.1 $\mu$ F	10%	0603	Murata	04023C103KAT2A
J1, J2	2	Banana Connector	n/a	n/a	7 mm Hole	Johnson Components	111-2223-001
J3, J4	2	3-Pin Header	n/a	n/a	Header3	Tyco Electronics	5-826629-0
J3, J4	2	2-Pin Jumper	n/a	n/a	n/a	Tyco Electronics	4-881545-2
J5	1	USB TypeA Connector	n/a	n/a	USB TypeA	Mill-Max	896-43-004-00-000000
J6, J7	2	USB TypeB Connector	n/a	n/a	USB TypeB	Adam Tech	USB-B-S-RA
J8, J9, J10, J11	4	Standoff Nut	n/a	n/a	n/a	Keystone Electronics	1903C
J8, J9, J10, J11	4	Standoff Screw	n/a	n/a	n/a	Keystone Electronics	4814K-ND
TP1	1	PCB Shorting Link	n/a	n/a	n/a	Harwin	D3082-46
TP2, TP3, TP4, TP5, TP6, TP7	6	Test Point PC Multi Purpose	n/a	n/a	1.6mm hole	Keystone Electronics	5010
U1	1	NLAS7242 DPDT Switch	n/a	n/a	UQFN10	ON Semiconductor	NLAS7242MUTBG

# NLAS7242MUGEVB

## PCB LAYOUT

The PCB and components are made of lead-free and RoHS compliant materials. The layout is shown in Figure 5 below. Ground pours are present on the top and bottom

layers for connectivity. The top layer traces are shown in magenta, and the bottom layer traces are shown in cyan. PCB dimensions are 53 mm x 58 mm x 1 mm.

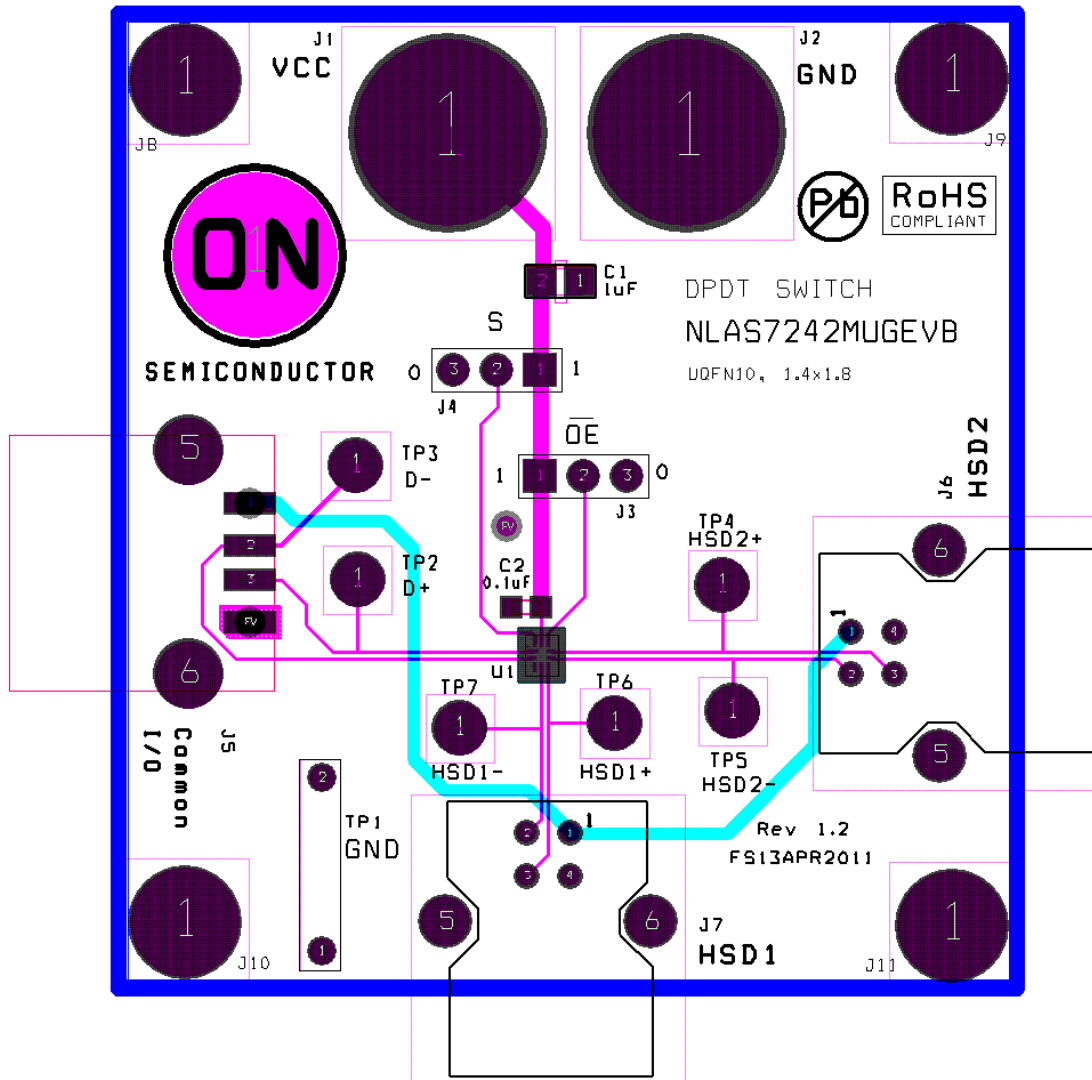

Figure 5. Evaluation Board Layout

## PCB LAYOUT GUIDELINES

### Electrical Layout Considerations

Implementing a high speed USB switch device requires paying attention to data lines and traces to preserve signal integrity. The demonstration board serves as layout example and can support the design engineers to preserve high speed performances.

Electrical layout guidelines are:

- The bypass capacitor must be placed as close as possible to the V<sub>CC</sub> input pin for noise immunity.
- The characteristic impedance of each switch segment must be 45 Ω.
- The ground plane of the PCB will be used to determine the characteristics impedance of each line.
- All corresponding D+/D- line segment pairs must be the same length.
- The use of vias to route these signals should be avoided when possible.
- The use of turns or bends to route these signal should be avoided when possible.

**ON Semiconductor** and  are registered trademarks of Semiconductor Components Industries, LLC (SCILLC). SCILLC reserves the right to make changes without further notice to any products herein. SCILLC makes no warranty, representation or guarantee regarding the suitability of its products for any particular purpose, nor does SCILLC assume any liability arising out of the application or use of any product or circuit, and specifically disclaims any and all liability, including without limitation special, consequential or incidental damages. "Typical" parameters which may be provided in SCILLC data sheets and/or specifications can and do vary in different applications and actual performance may vary over time. All operating parameters, including "Typicals" must be validated for each customer application by customer's technical experts. SCILLC does not convey any license under its patent rights nor the rights of others. SCILLC products are not designed, intended, or authorized for use as components in systems intended for surgical implant into the body, or other applications intended to support or sustain life, or for any other application in which the failure of the SCILLC product could create a situation where personal injury or death may occur. Should Buyer purchase or use SCILLC products for any such unintended or unauthorized application, Buyer shall indemnify and hold SCILLC and its officers, employees, subsidiaries, affiliates, and distributors harmless against all claims, costs, damages, and expenses, and reasonable attorney fees arising out of, directly or indirectly, any claim of personal injury or death associated with such unintended or unauthorized use, even if such claim alleges that SCILLC was negligent regarding the design or manufacture of the part. SCILLC is an Equal Opportunity/Affirmative Action Employer. This literature is subject to all applicable copyright laws and is not for resale in any manner.

## PUBLICATION ORDERING INFORMATION

### LITERATURE FULFILLMENT:

Literature Distribution Center for ON Semiconductor  
P.O. Box 5163, Denver, Colorado 80217 USA  
**Phone:** 303-675-2175 or 800-344-3860 Toll Free USA/Canada  
**Fax:** 303-675-2176 or 800-344-3867 Toll Free USA/Canada  
**Email:** [orderlit@onsemi.com](mailto:orderlit@onsemi.com)

**N. American Technical Support:** 800-282-9855 Toll Free  
USA/Canada  
**Europe, Middle East and Africa Technical Support:**  
Phone: 421 33 790 2910  
**Japan Customer Focus Center**  
Phone: 81-3-5773-3850

**ON Semiconductor Website:** [www.onsemi.com](http://www.onsemi.com)  
**Order Literature:** <http://www.onsemi.com/orderlit>  
For additional information, please contact your local  
Sales Representative