

Schematic for the NCN6001 Demonstration Board

ON Semiconductor



4/2/2004

Smart Card Interface:

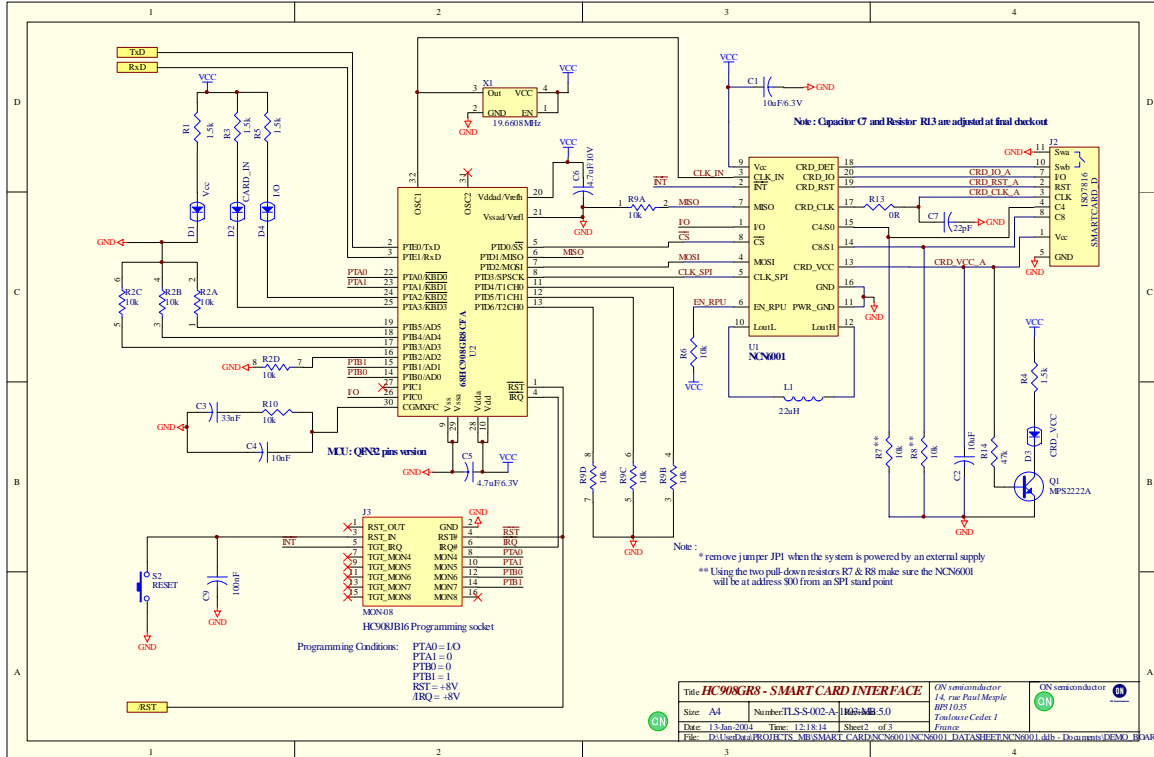

Power Supply & RS232:

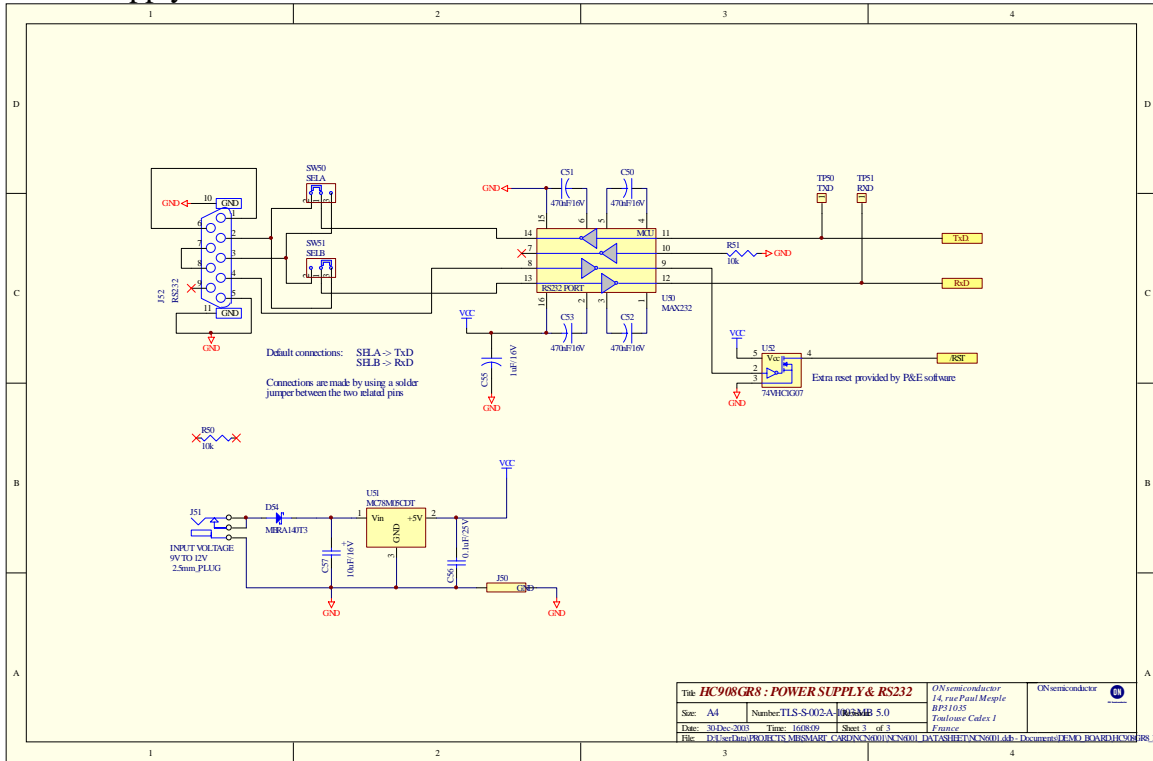

Title: HC908GR8 : POWER SUPPLY & RS232		ON Semiconductor	ON Semiconductor
Size: A4	Number: T1S-S-002-A-003MB 5.0	14, rue Paul Meple	BP91035
Date: 01-Dec-2003	Time: 16:08:09	Zimrose, Cales 1	
File: D:\user\don\PROJECTS\MISSMART_CARD\2S-2001\N-2001\DAT\SHIB\TNS-2001.A4 - Documents\FEMO_BOA8010328.dwg		France	
Sheet 3 of 3			