



ON Semiconductor

Test Procedure for the NCP3125 Ceramic Evaluation Board

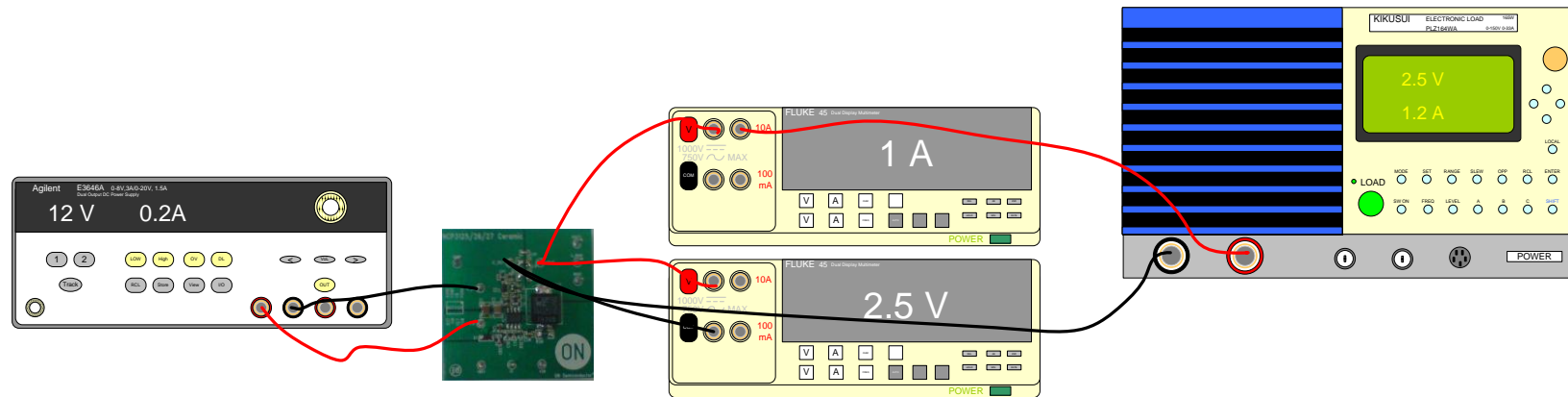

Figure 1: Test Setup

The following steps describe the test procedure for all these boards:

Suggested Equipment:

Current limited DC Power Supply (e.g. AGILENT 6645A)	1pc
DC Volt-Meter able to measure up to 60 V DC (e.g. KEITHLEY 2000)	2pcs
DC Amp-Meter able to measure up to 1 A DC (e.g. KEITHLEY 2000)	1pc
DC Amp-Meter able to measure up to 5 A DC (e.g. FLUKE 89 IV).....	1pc
DC Electronic Load (e.g. AGILENT 6060B)	1pc

Test Procedure:

1. Connect the test setup as shown in Figure 1.
2. Apply an input voltage, $V_{IN} = 4.5-13.2$ Vdc
3. Apply $I_{OUT}(\text{load}) = 0$ A
4. Check that $V_{OUT} = 2.5$ Vdc
5. Set I_{OUT} to desired level 0 A- 4 A
6. Check that $V_{OUT} = 2.5$ Vdc
7. Turn off the load
8. Turn off V_{IN}
9. End of the test