

NCV7680-NCV3163EVB

NCV7680 - NCV3163 Evaluation Board Manual

Prepared by: David Berdy
ON Semiconductor



ON Semiconductor®

<http://onsemi.com>

EVALUATION BOARD MANUAL

Description

The NCV7680 is an octal LED driver designed for automotive LED rear combination lamps. External programmability of the NCV7680 allows the user to set the tail current and stop currents using a single resistor for each function. An optional external FET is used to help distribute power for high power systems.

The NCV7680-NCV3163 Evaluation Board includes both an NCV7680 (octal driver) and NCV3163 (Boost Regulator). The NCV3163 allows for an increased number of LEDs per NCV7680 output by boosting the LED string anode voltage. The DIAG pin is brought out for reporting of open circuit conditions.

The LED's mounted on the demo board are jumpered giving flexibility for evaluating customer defined loads.

Part Features

- Constant Current Outputs for LED String Drive
- Open LED String Diagnostic with Open-Drain Output
- Low Dropout Operation for Pre-Regulator Applications
- External Modulation Capable

- On-chip 1 kHz Tail PWM Dimming
- Single Resistor for Stop Current Set Point
- Single Resistor for Tail Dimming Set Point
- Overvoltage Set Back Power Limitation
- AEC Q100 Qualified
- 16 Lead SOW Exposed Pad
- These are Pb-Free Devices

Board Features

- STOP Input Switch – Controls power to the circuit
- DIAG Output – Open Circuits are Reported
- LED Isolation – On-board LEDs can be Removed with Jumpers for Alternative LED Evaluation
- STOP Programming Current – Programming Resistor can be Adjusted Externally by Jumper Removal
- External PWM Input
- Adjustable Boost Circuit with Internal Switch – Set for 28 V on the NCV7680-NCV3163EVB Demo Board
- These Devices are Pb-Free and are RoHS Compliant

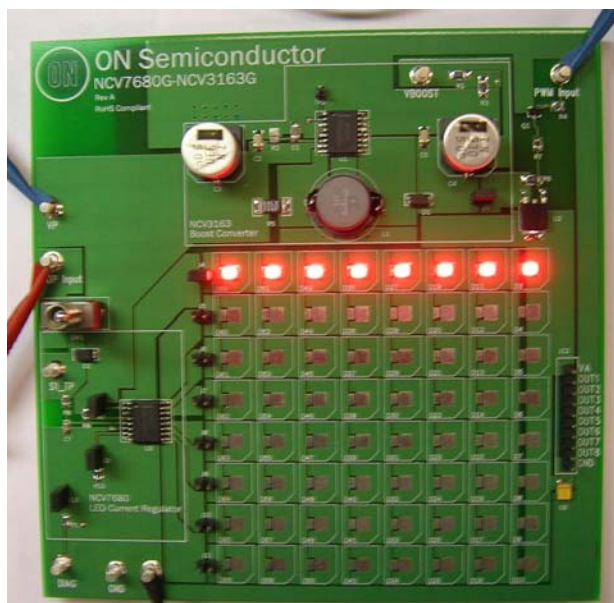

Figure 1. NCV7680-NCV3163EVB Photo

NOTE: For 100% Duty Cycle operation, connect the PWM Input post to the VP post. The default setup (with the 2 posts floating) yields 0% Duty Cycle.

NCV7680-NCV3163EVB

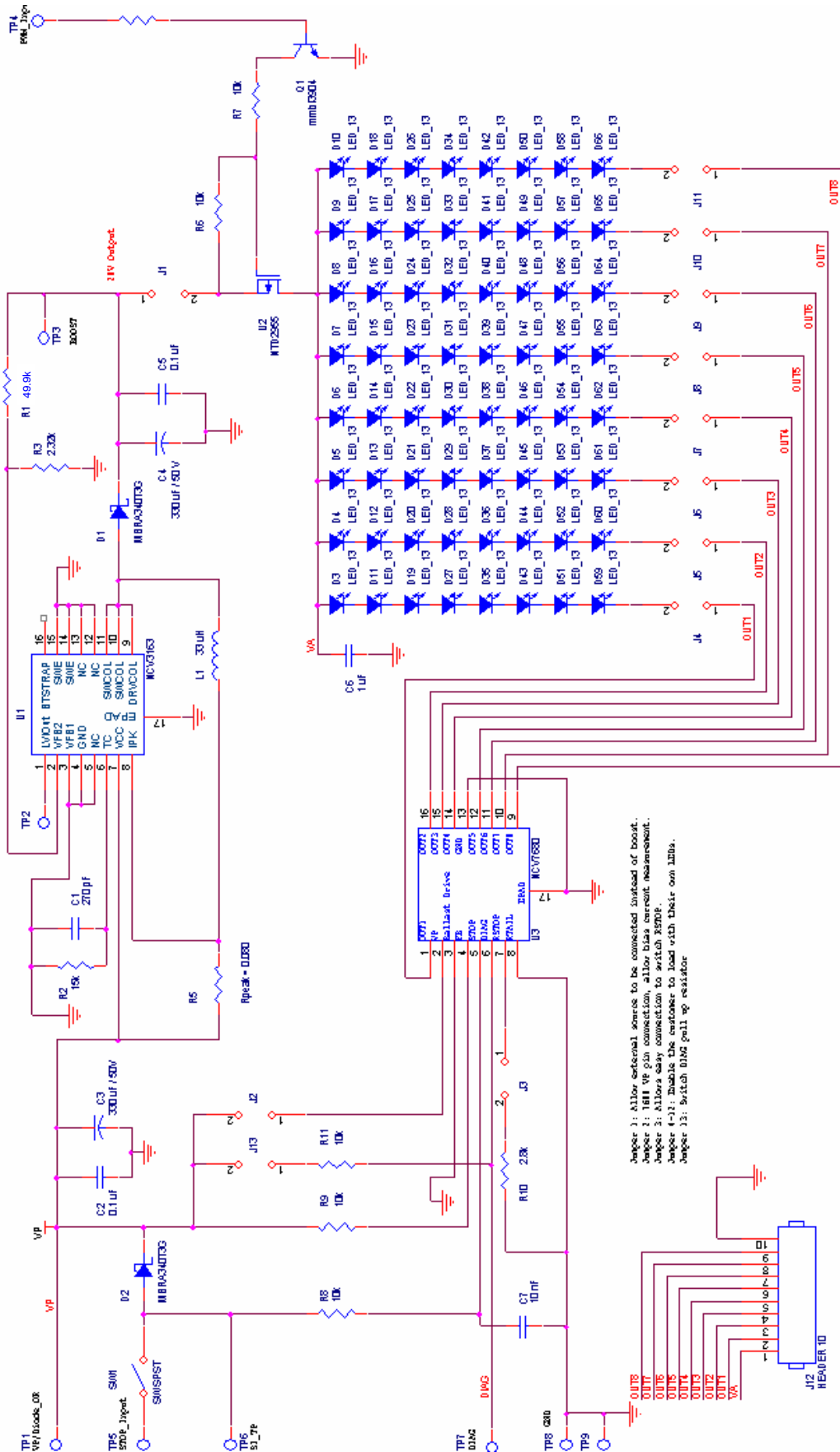

Figure 2. NCV7680-NCV3163EVB Schematic

NCV7680-NCV3163EVB

Powering up the Board

Equipment Needed

- 1 power supply (2 A)
- 1 Function Generator (200 Hz)
 1. There are 12 jumpers on the board. Start with all 12 jumpers connected. Jumper locations are shown in Figure 3. A list of jumper functionality is shown in the board schematic (Figure 2).

2. Typical connections to the evaluation board are shown in Figure 4. Set the PWM input to a 200 Hz 5 V square wave when using external PWM. To disable PWM and run at 100% duty cycle, connect PWM Input to VP.
3. Connect the power supply, 13.2 V typical for a car battery
4. Position switch 1 (SW1) left to turn the circuit off, and right to turn the circuit on.

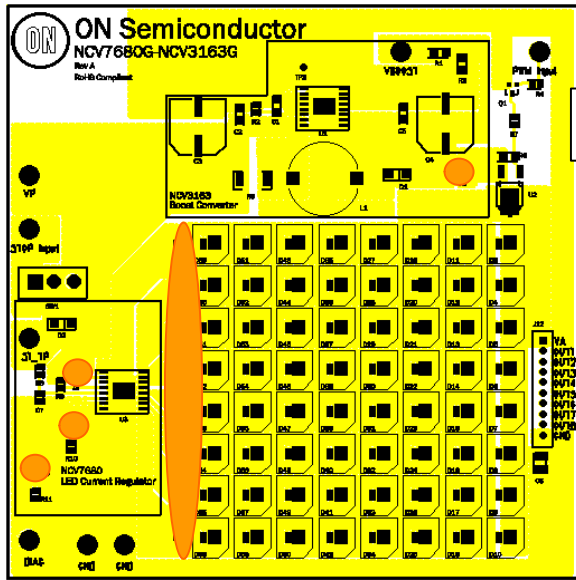

Figure 3. Jumper Locations

NOTE: Unloaded OUTx pins should be grounded for proper operation.

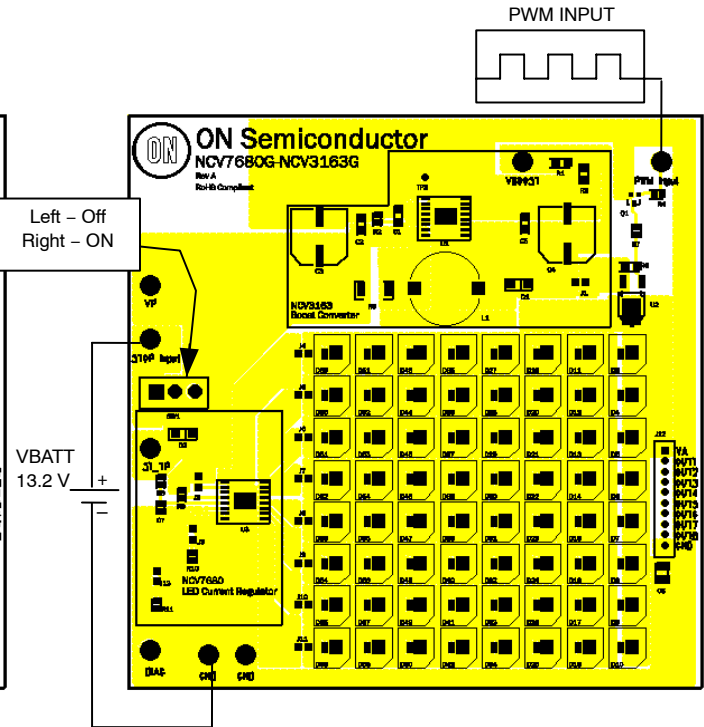

Figure 4. Power Connections

NOTE: For 100% Duty Cycle operation, connect the PWM Input post to the VP post. The default setup (with the 2 posts floating) yields 0% Duty Cycle.

NCV7680-NCV3163EVB

Jumpers 4-11: DIAG Reporting of Open Circuit

Jumpers 4-11 highlight the open circuit functionality of diagnostic pin (DIAG).

Monitor DIAG while creating an open circuit by removing any on these jumpers (4-11). DIAG will go high when an open is detected.

NOTE: If external PWM is being used, the DIAG will always report an “open” (high value) while the PWM Input is low (i.e. the LEDs are off). Therefore, to check if an open is occurring on any output LED strand, only check DIAG when PWM Input is high.

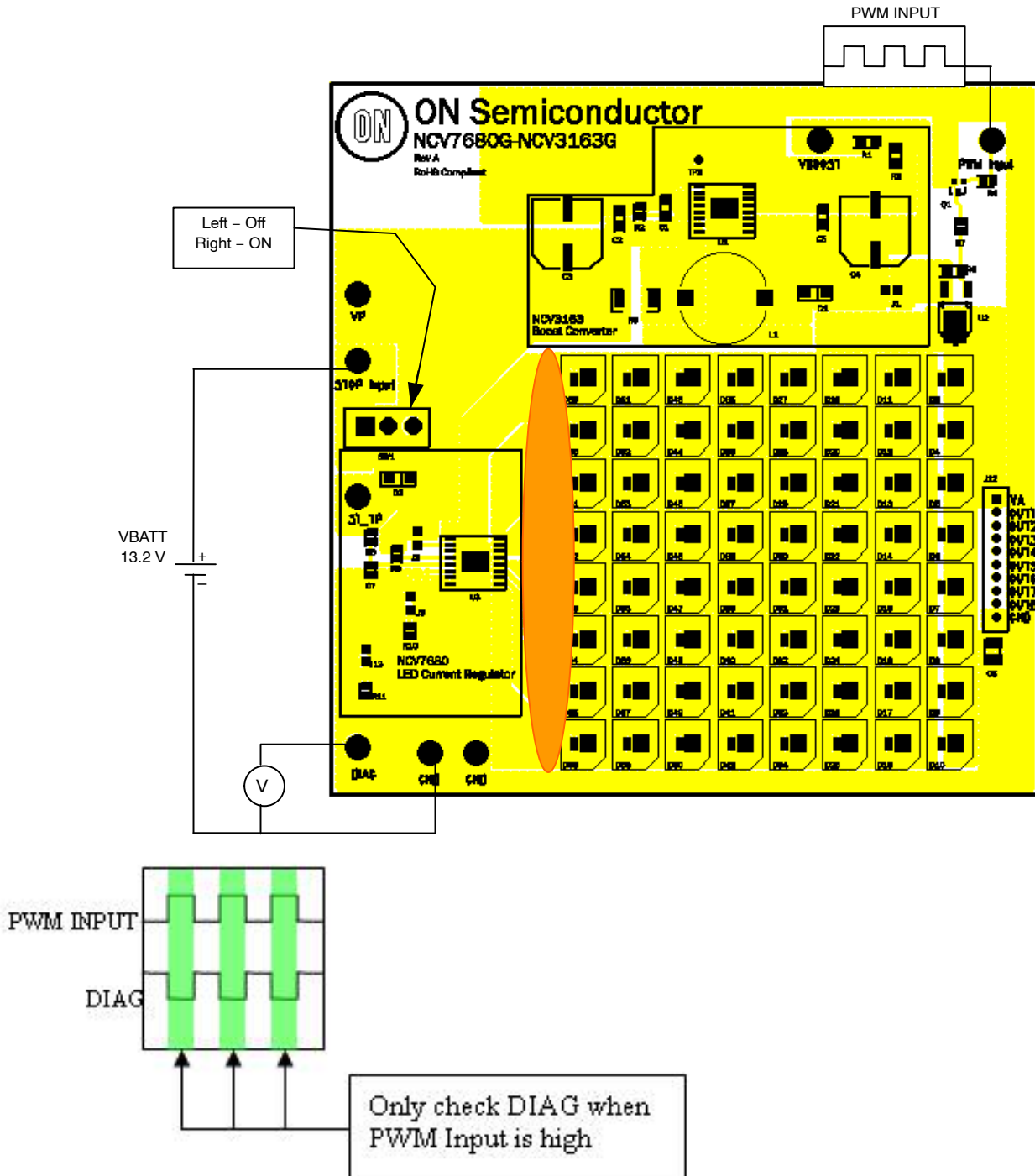

Figure 5. Open Circuit Detection

NCV7680–NCV3163EVB

Jumper 13, DIAG Load

Jumper 13 disconnects the PC board pullup resistor and allows the user to interface their own component and power supply to the DIAG pin.

Disconnect Jumper 13. Connect the external resistor to a separate supply. The DIAG pin is limited to 45 V per the maximum ratings table.

Figure 6 shows the test setup for using DIAG with a separate supply.

MAXIMUM RATINGS (Voltages are with respect to device substrate)

Rating	Value	Unit
VP, Ballast Drive, STOP, DIAG DC Peak Transient	-0.3 to 45 45	V
Output Pin Voltage (OUTX)	-0.3 to 45	V
Output Pin Current (OUTX)	100	mA
Input Voltage (RTAIL, RSTOP, FB)	-0.3 to 5	V
Junction Temperature, T _J	-40 to 150	°C
Peak Reflow Soldering Temperature: Pb-Free 60 to 150 seconds at 217°C (Note 1)	260 peak	°C

Stresses exceeding Maximum Ratings may damage the device. Maximum Ratings are stress ratings only. Functional operation above the Recommended Operating Conditions is not implied. Extended exposure to stresses above the Recommended Operating Conditions may affect device reliability.

- For additional information, see or download ON Semiconductor's Soldering and Mounting Techniques Reference Manual, SOLDERRM/D, and Application Note AND8003/D.

DIAG Output

Characteristic	Conditions	Min	Typ	Max	Unit
Output Low Voltage	DIAG Active, I _{DIAG} = 1 mA	-	0.1	0.40	V
Output Leakage Current	V _{DIAG} = 5 V	-	-	10	µA

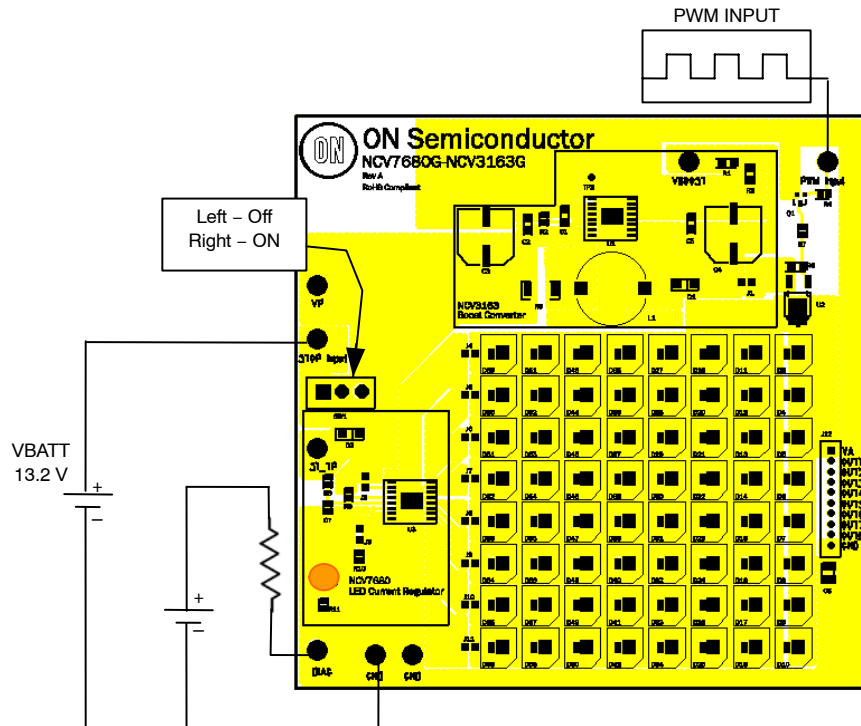

Figure 6. DIAG Connection

NCV7680-NCV3163EVB

Jumper 3, Program Current

Jumper 3 allows the user to program the LED output current. The value of RSTOP (R10) initially on the board is 4.3k, 25 mA through each output. Remove the jumper to disconnect the PC board resistor and connect a different value.

Resistor values and resultant output programmed currents can be calculated using these design equations:

$$OUTX = 100 \times \frac{R_{STOP_Bias_Voltage}}{R_{STOP}} \quad (eq. 1)$$

$$R_{STOP} \text{ Bias Voltage} = 1.08 \text{ V (typ)}$$

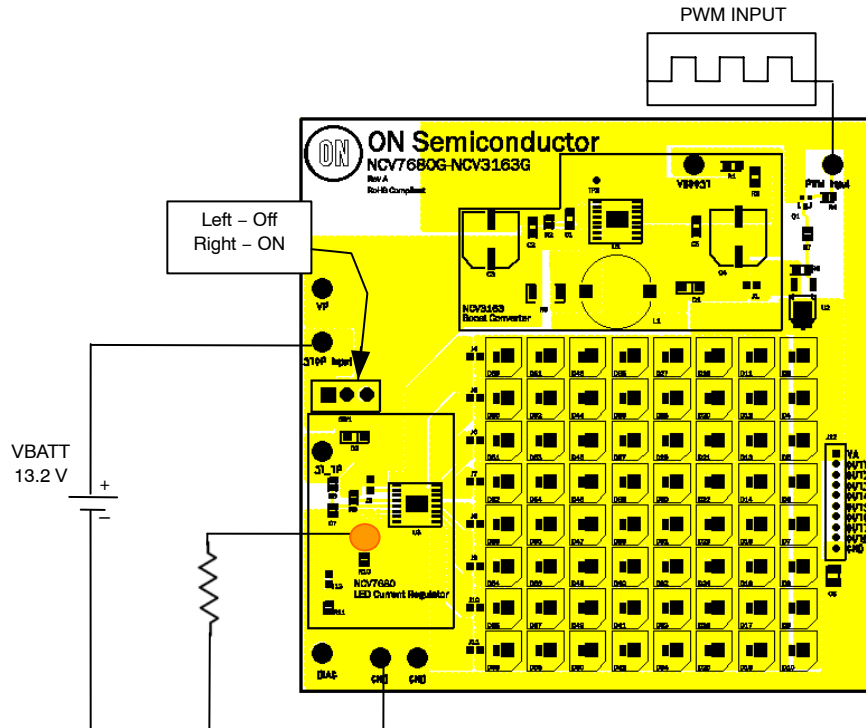

Figure 7. RSTOP Programming Resistor

NCV7680-NCV3163EVB

Jumper 1, Boost Voltage

Jumper 1 disconnects the boost voltage from the LED anode. This allows the user to connect an external source in place of the boost as seen in Figure 8.

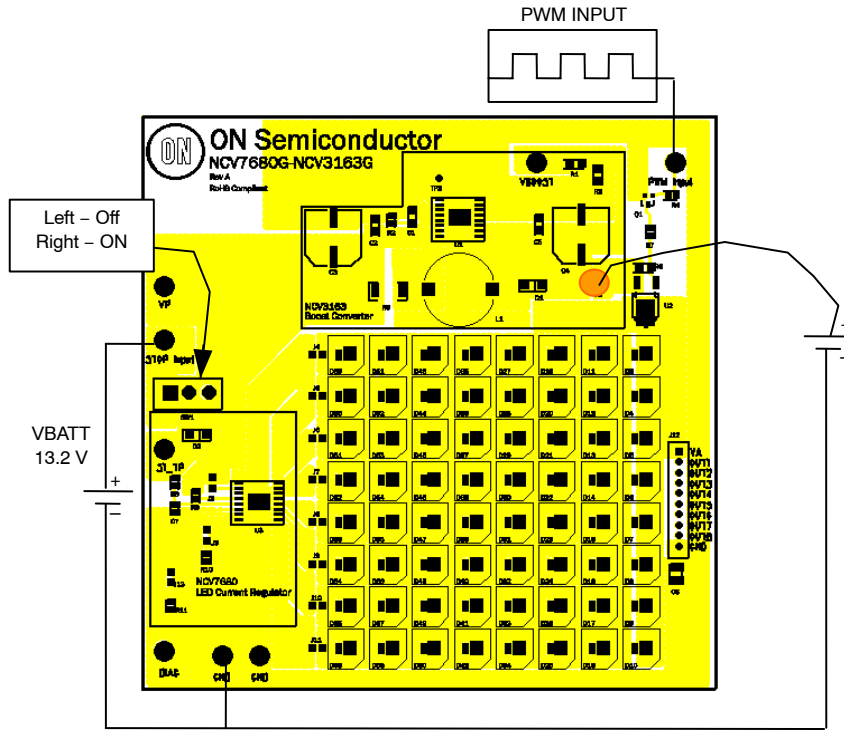

Figure 8. External Boost or Other Source Connection

NCV7680-NCV3163EVB

External LED Connection

Jumpers 4 through 11 allow the user to connect additional LEDs or an entirely different set of LEDs in place of the LEDs on the board. Figure 9 shows an external set of LEDs connected to the board while the on-board LEDs are disconnected (J4-11 removed).

Figure 10 shows how to connect additional LEDs in series with the on-board LEDs to increase the number of LEDs per strand. Note that you will need to increase the boost voltage or use an external source to drive the same current.

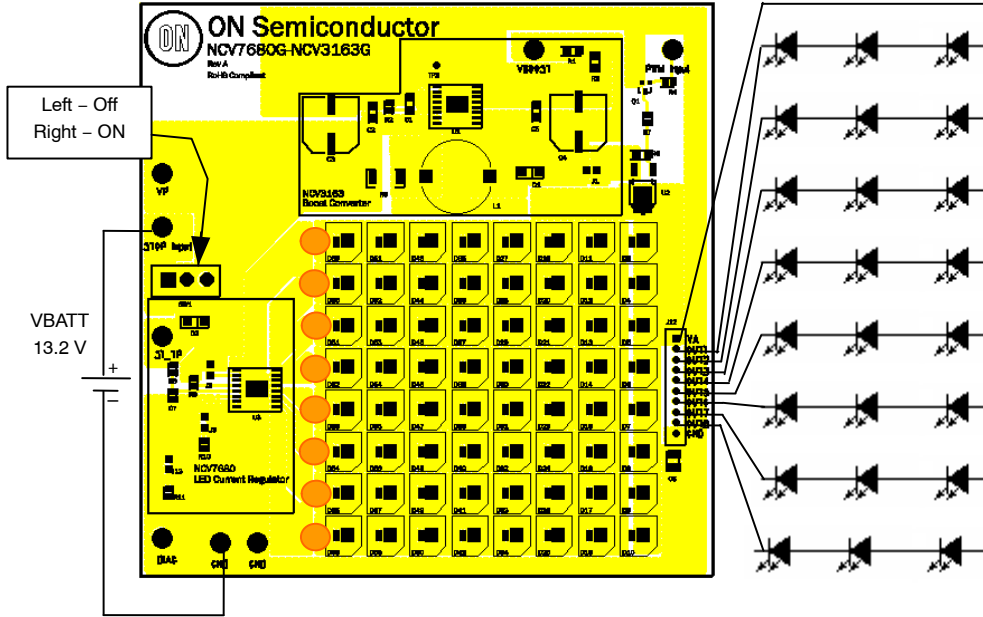

Figure 9. External LEDs

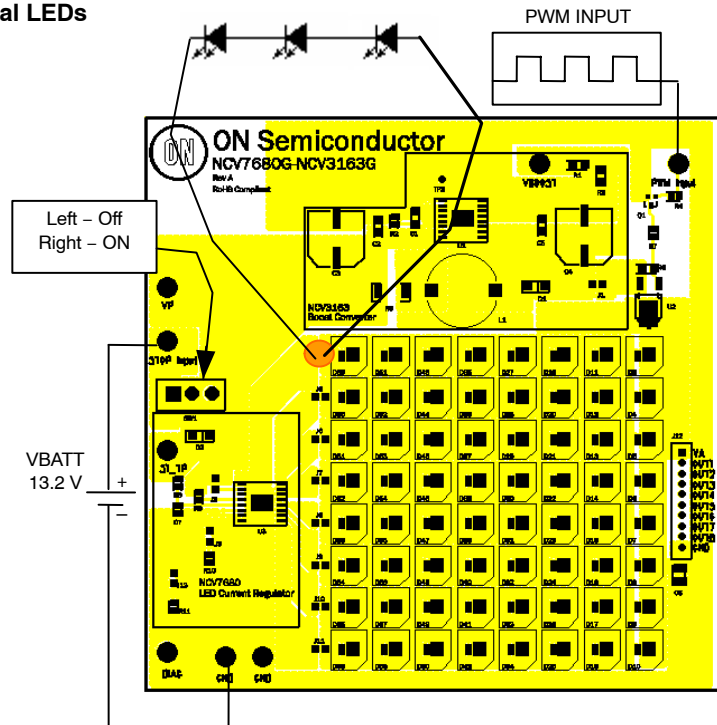

Figure 10. Additional LEDs (Only One Strand Shown)

NCV7680-NCV3163EVB

Boost Voltage

Resistors R3 and R1 set the boost regulation voltage. This resistor network may be changed to regulate to a different voltage. Please follow the NCV3163 design spreadsheet (located at www.onsemi.com).

The internal switch of the NCV3163 is rated at 3.4 A max, raising the regulation voltage or current too high may cause the boost circuit to operate undesirably or require different components.

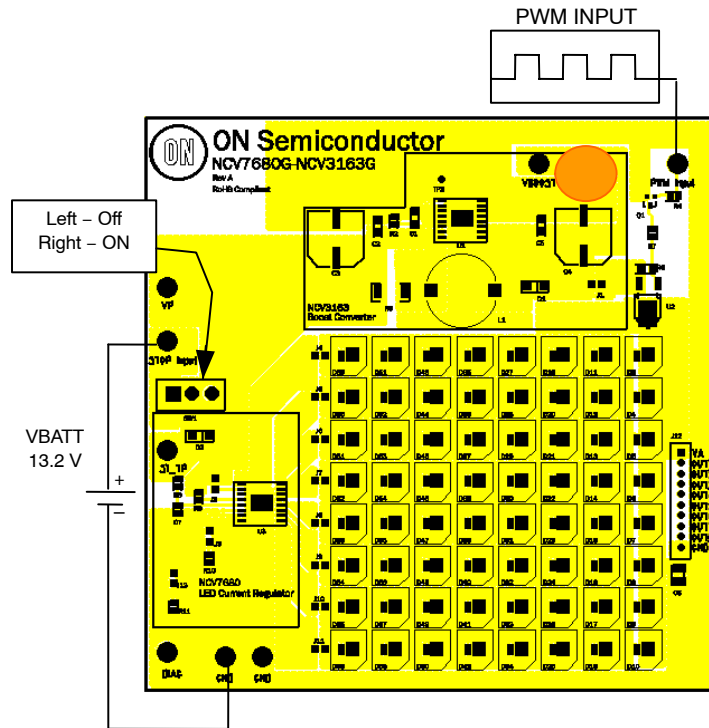

Figure 11. Boost Feedback Resistor Network

NCV7680-NCV3163EVB

Jumper 2, VP Connection

Jumpers 2 allows for measurement of the 7680 bias current.

BILL OF MATERIALS (NCV7680-NCV3163 Demonstration Board)

Des.	Qty	Description	Val	Tol	Footprint	Manufacturer	Manufact. P/N	Substitution Allowed
C1	1	Timing Capacitor	100 pF	10%	1206	Yageo	CC1206JRNPO9BN101B	Yes
C2, C5	2	Input Capacitor	0.1 µF	10%	1206	Yageo	CC1206KRX7R9BB104	Yes
C3, 4	2	Electrolytic Capacitor	330 µF / 50 V	20%	12.5 mm x 13.5 mm	Panasonic	EEV-TG1H331Q	Yes
C6	1	Output Capacitor	1 µF	10%	1210	Kemet	C1210C105K3RACTU	Yes
C7	1	Debounce Cap	10 nF	10%	805	Yageo	CC0805KRX7R9BB103	Yes
D1, D2	2	Schottky Rectifier	3 A / 40 V	-	SMA	ON Semiconductor	MBRA340T3G	No
D3-66	64	OSRAM TOPLED	Red	-	PLCC-2	OSRAM	LS T67B-S1U1-1-0-30-R18-Z	Yes
J1-11, 13	13	Jumper (100 mil spacing)	-	-	JMP	Molex-Waldom Electronics Corp	22-28-4103	Yes
J12	1	10 SIP Jumper (100 mil spacing)	-	-	SIP10	Molex-Waldom Electronics Corp	22-28-4023	Yes
L1	1	Inductor	33 µH / 4.5 A	-	15.24 mm x 18.54 mm	Coilcraft	DO5022P-333	Yes
Q1	1	PWM Logic	-	-	SOT23	ON Semiconductor	MMBT3904LT3G	No
R1	1	Output Program Resistor	49.9k for 28 V	1%	1206	Vishay	CRCW120649K9FKEA	Yes
R2	1	Timing Resistor	NU	NU	NU	NU	NU	Yes
R3	1	Output Program Resistor	2.32k	1%	1206	Vishay	CRCW12062K32FKEA	Yes
R4, 7-9, 11	5	Resistor	10k	1%	805	Vishay	CRCW080510K0FKEA	Yes
R5	1	Peak Current Sense Resistor	0.08	1%	2512	Vishay	WSL2512R0800FEB	Yes
R6	1	Pull-up Resistor	10k	1%	1206	Vishay	CRCW120610K0FKEA	Yes
R10	1	Current Program Resistor	4.3k (25 mA)	5%	805	Panasonic - ECG	ERJ-6GEYJ432V	Yes
SW1	1	Power Switch	-	-	C&K_7101	C&K	7101SYCQE	Yes
TP1, 3-8	7	Connector Posts	-	-	TURRET	Vector Electronics	K24C/M	Yes
TP2	1	Test Via	NU	NU	NU	NU	NU	Yes
U1	1	NCV3163	-	-	SOIC16W EPAD	ON Semiconductor	NCV3163PWG	No
U2	1	NTD2955	-	-	DPAK	ON Semiconductor	NTD2955T4G	No
U3	1	NCV7680	-	-	SOIC16W EPAD	ON Semiconductor	NCV7680PDWG	No

ON Semiconductor and  are registered trademarks of Semiconductor Components Industries, LLC (SCILLC). SCILLC reserves the right to make changes without further notice to any products herein. SCILLC makes no warranty, representation or guarantee regarding the suitability of its products for any particular purpose, nor does SCILLC assume any liability arising out of the application or use of any product or circuit, and specifically disclaims any and all liability, including without limitation special, consequential or incidental damages. "Typical" parameters which may be provided in SCILLC data sheets and/or specifications can and do vary in different applications and actual performance may vary over time. All operating parameters, including "Typicals" must be validated for each customer application by customer's technical experts. SCILLC does not convey any license under its patent rights nor the rights of others. SCILLC products are not designed, intended, or authorized for use as components in systems intended for surgical implant into the body, or other applications intended to support or sustain life, or for any other application in which the failure of the SCILLC product could create a situation where personal injury or death may occur. Should Buyer purchase or use SCILLC products for any such unintended or unauthorized application, Buyer shall indemnify and hold SCILLC and its officers, employees, subsidiaries, affiliates, and distributors harmless against all claims, costs, damages, and expenses, and reasonable attorney fees arising out of, directly or indirectly, any claim of personal injury or death associated with such unintended or unauthorized use, even if such claim alleges that SCILLC was negligent regarding the design or manufacture of the part. SCILLC is an Equal Opportunity/Affirmative Action Employer. This literature is subject to all applicable copyright laws and is not for resale in any manner.

PUBLICATION ORDERING INFORMATION

LITERATURE FULFILLMENT:
 Literature Distribution Center for ON Semiconductor
 P.O. Box 5163, Denver, Colorado 80217 USA
Phone: 303-675-2175 or 800-344-3860 Toll Free USA/Canada
Fax: 303-675-2176 or 800-344-3867 Toll Free USA/Canada
Email: orderlit@onsemi.com

N. American Technical Support: 800-282-9855 Toll Free USA/Canada
Europe, Middle East and Africa Technical Support:
 Phone: 421 33 790 2910
Japan Customer Focus Center
 Phone: 81-3-5773-3850

ON Semiconductor Website: www.onsemi.com
Order Literature: <http://www.onsemi.com/orderlit>
 For additional information, please contact your local Sales Representative