

L5961

Power management solution with integrated power supplies for MOST® automotive networks



STMicroelectronics' L5961 is the most compact, complete and flexible power management solution for MOST (media oriented systems transport) networks.

Replacing discrete components with a one-chip solution, the L5961 provides benefits in terms of cost and space savings.

It is specifically designed to form a chipset with SMSC's MOST network processor, and so can be used as a building block in any MOST node, independently of the application. The L5961 helps customers reduce design time and resources, and also ensures MOST compliance.

Based on the autonomous network operation principle, the L5961 decouples the MOST network from the influence and timing of the applications connected to it. The L5961 thus significantly improves network robustness against disturbances and potential failures. The current capability of the integrated DC/DC converter is able to drive a small application (such as GPS antenna or tuner box) in addition to INIC/NIC controller, thus replacing completely power supply for such small applications. With zero and ultra-zero power modes, the L5961 features a very low standby consumption to meet the most demanding car manufacturer requirements.

Key features

- 5 or 3.3 V/650 mA DC-DC converter (INIC/NIC supply)
- 5 or 3.3 V/40 mA standby voltage regulator (FOR supply)
- 5 or 3.3 V/60 mA switchable regulator (FOT supply)
- Very low quiescent current: zero and ultra-zero power modes
- I²C interface allows programmable system configuration
- Four different wake-up event triggers
 - Switch to power pulse (STPP)
 - Light on (FOR status)
 - Activity on Diag_I/O
 - On/off switch
- Reset generator
- Three battery detectors for battery voltage monitoring
- Intrinsic diagnostic transceiver (LIN 2.0 standard)
- Watchdog circuit
- PowerSS036/PowerSO36 packages

Key benefits

- Highly optimized cost and space for MOST network power management, with the single-chip solution: L5961 integrates all the power supplies needed for a MOST node
- Easiest implementation of the solution (plug-and-play approach)
- MOST compliance
- Highly-effective power-saving modes: very low standby consumption
- Chipset solution with SMSC's MOST network processor
- Intrinsic fail-safe behavior
- Very flexible solution thanks to system configurability, compatibility with main standard diagnostic protocols and support of different wake-up events
- High current capability of integrated DC/DC converter (able to drive a small application in addition to INIC/NIC controller)



Application diagram example with INIC controller

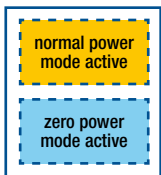
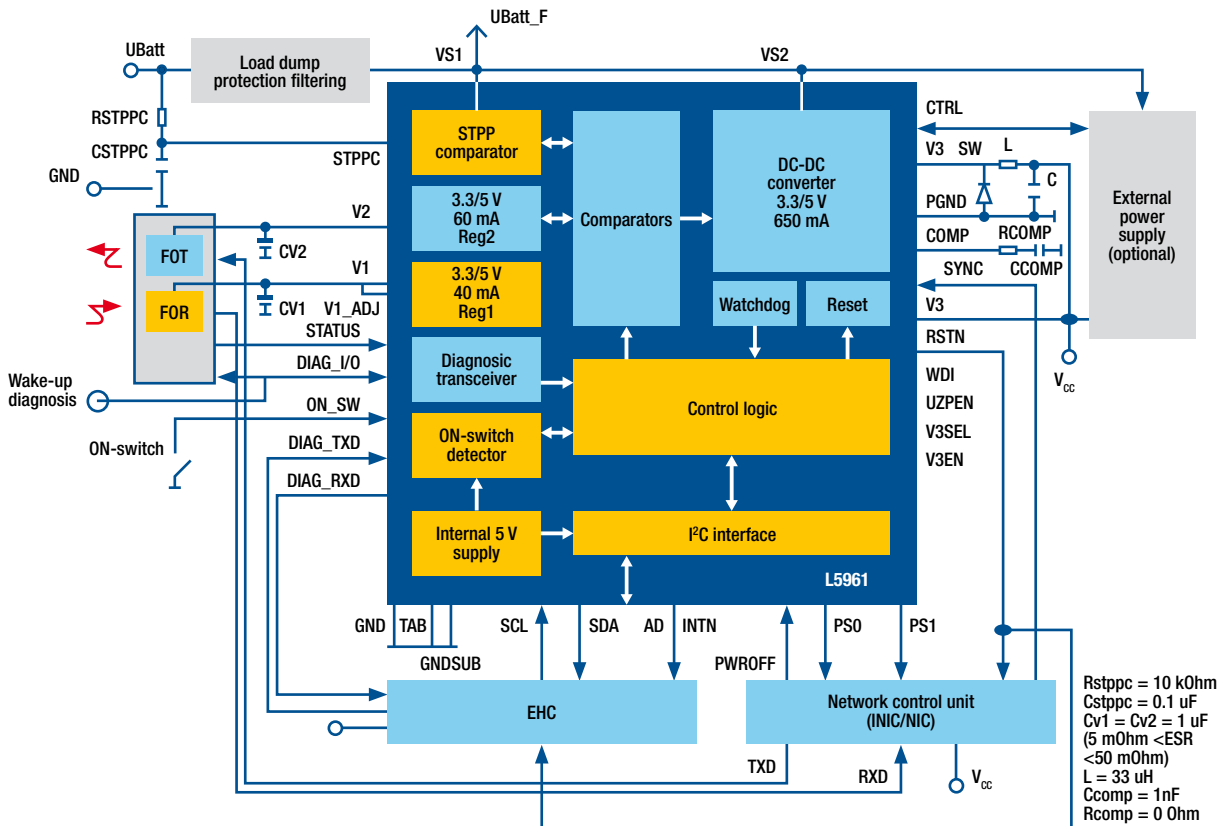

For further information please contact ST sales office in your country or visit www.st.com/most_pmd



© STMicroelectronics - February 2008 - Printed in Italy - All rights reserved

The STMicroelectronics corporate logo is a registered trademark of the STMicroelectronics group of companies. MOST is a trademark of Standard Microsystems Corp. (SMSC). All other names are the property of their respective owners.

For selected STMicroelectronics sales offices fax:

China +86 21 52574820; France +33 1 55489569; Germany +49 89 4605454; Italy +39 02 8250449; Japan +81 3 57838216; Singapore +65 6481 5124; Sweden +46 8 58774411; Switzerland +41 22 9292900; United Kingdom and Eire +44 1628 890391; USA +1 781 861 2678

Full product information at www.st.com

Order code: FL59610308

www.BDTIC.com/ST



Recycled and chlorine free paper