



FLI7510

Freeman Lite — iDTV SoC worldwide H.264/MPEG decoder + Faroudja video processing

Data brief

Features

- ST231 @ 450 MHz for advanced high definition video decoding (H.264/VC-1/MPEG2/...) --> Worldwide Digital Terrestrial Television (DTT) broadcast video standards compatibility
- Dual ST231 @ 450 MHz for advanced multi-channel audio decoding (MPEG-1/2, MP3, WMA, Dolby® Digital/Dolby Digital+, AAC/AAC+/...) --> Worldwide DTT broadcast audio standards compatibility
- Dual ST40 CPU @ 450 MHz (delivers 1600 DMIPS) runs Linux and OS21 --> One CPU (800 DMIPS) fully dedicated to application and user interface
- Faroudja® video processing for Main Video --> Vivid picture quality for the consumer
- 14-bit Advanced Color Management (3D) and Contrast processing --> Ultimate video quality for OEMs and consumers
- Award-winning DCDi, MADi technologies --> Crystal-clear rendering on 1080p displays
- Worldwide analog audio demodulator
- Physical graphics planes enabling rich, easy-to-use user I/Fs
- Extensive analog A/V and digital HDMI (x3) inputs --> End-user convenience for legacy and future content source boxes
- DVR support on Flash/HDD --> Integration into DTV results in convenience and ease-of-use
- Extensive connectivity (USB host controller and Ethernet MAC) --> Play back content from anywhere in home or from Internet
- Advanced security with trusted ST40 CPU and DRM support including HDCP, AES/3DES, CI/CI+ and DTCP-IP --> Protects IP & content
- 2 x 16 bits DDR2/DDR3 1066 Mbps DRAM I/F --> Performance and flexibility with DRAM ICs
- Dual high-speed 10-bit LVDS outputs --> Convenient connectivity to panel TCON
- Board Support Package (BSP) API accelerates time to market

Applications

- Connected, high-performance, and mainstream iDTVs with support for 3DTVs
- Multi-region, single footprint for DVB/ATSC/DTMB/ISDB

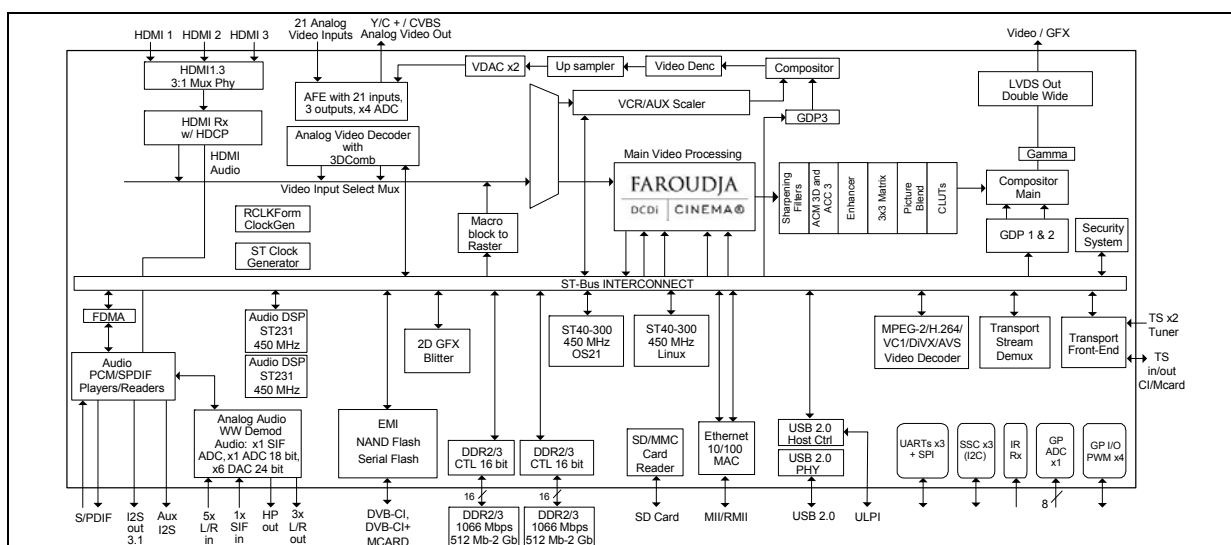

1 Description

The FLI7510 is a revolutionary new iDTV SoC that integrates two highly successful, market-proven subsystems: STi710x digital/front-end processing and multi-format audio/video decoding from the STB market, and Faroudja video/back-end processing from the TV market. The FLI7510 is a high-performance, state-of-the-art SoC that can power DTT/cable/satellite/IPTV iDTV designs for worldwide deployment. From the software compatibility extending from the mature STi710x STAPI layer to the extensive video processing, tuning, and tools from Faroudja Labs, the FLI7510 is the ideal solution for addressing the next generation of iDTV design requirements.

The FLI7510 is the first in a family of scalable in performance and software compatible SoCs that address mainstream and performance segments of the iDTV market.

The FLI7510 implements the latest generation of Faroudja Video Optimized technologies, which allow a high degree of customization for TV OEMs. Key technology improvements in this area include 14-bit color and contrast processing, upgraded sharpness, upgraded temporal noise reduction, and new MPEG noise reduction.

The FLI7510, with high performance CPU, A/V decode, graphics engine, and extensive network interface capability, enables TVs to deliver rich applications for convenient access to multimedia content, both from within the home, as well as from the web.

2 Main features

The FLI7510 is a new, advanced decoding SoC targeted at next generation iDTVs (DTT, as well as with combinations of cable/satellite/IPTV). It integrates in a single IC, multi-stream transport demux, CPU, multi-format audio/video decode, Faroudja video processing, graphics and display, advanced security, peripherals, audio/video ADCs/DACs, Digital A/V inputs/outputs, 3x HDMI switch, dual USB ports, Ethernet MAC, and glueless SD/MMC card interface.

2.1 Audio/video decoding

- Latest generation “Delta” Video Decoder with ST231 programmable CPU core:
 - MPEG2, H.264, VC-1, HD or SD
 - AVS SD decoding
 - DivX, XviD, H.263 decoding
- Advanced de-blocking and de-ringing of decoded H.264/MPEG2 HD/SD sources based on ST's Digital Source Enhancer (DSE) technology with 2D analysis window and Texture Adaptive Filter
- Dual ST231 @ 450 MHz for advanced multi-channel audio decoding (MPEG-1/2, MP3, WMA, Dolby Digital/Dolby Digital+, AAC/AAC+). Concurrent audio description decoding. Dolby Digital+ and AAC+ transcoding to Dolby Digital/DTS. In addition, generous headroom remains for OEM post-processing algorithm implementation.

2.2 Graphics and display

- Main video display pipelines: high-quality H & V reformatting/resizing with sample rate conversion/filtering. Motion adaptive spatial and temporal de-interlacing for 480p/576p and 1080p60 progressive output
 - 14-bit color/contrast processing
 - 10-bit temporal/space noise reduction
 - DCDi diagonal processing
 - 10-bit Motion Adaptive Deinterlacing (MADi)
 - 10-bit arbitrary scaling, Sharpness (linear and non-linear)
- Independent Main display compositions (Video/Graphics mixing)
- Pass-through display for graphics, Main video output concurrently with Main compositions (VCRO)
- Physical graphics planes for Main display composition. Options include:
 - One graphics plane at up to 1280 x 720p/32 bpp @ 60 Hz
 - One graphics plane at up to 1920 x 1080p/16 bpp resolution @ 60 Hz
 - Two graphics planes at up to 1920 x 1080p/8 bpp @ 60 Hz and 960 x 540/32 bpp @ 60 Hz

- Dedicated graphics plane for SD monitor/TV output
- Link list based 2D graphics blitter. Up to 200 Mpixels/sec with destination alpha blending. Capable of 3D-like user interface effects.
- HD display capture and down-conversion for concurrent HD and SD output of the main composition

2.3 3DTV/3D video

3D video is the ultimate entertainment experience to have at home. Bringing 3D to TV is about supporting the proper connectivity to 3D sources and FLI7510 supports all the connectivity options that are required.

- Supports 3D mandatory formats defined in HDMI 1.4a specification
- Supports Deep Color with mandatory 3D timings up to 12 bpc
- FLI7510 can be used with an enhancement device to support 1080p 240 Hz output to boost the quality of 3D playback by increasing the frame rate per eye

Table 1. 3D video formats supported

Input format	Output to enhancement device (1080p-240 Hz)
720p @ 50/60 Hz (frame packed)	720p @ 100/120 Hz (frame sequential)
1080p @ 24 Hz (frame packed)	1080p @ 48 Hz (frame sequential)
1080p @ 24 Hz (top-bottom half vertical resolution)	1080p @ 48 Hz (top-bottom half vertical resolution), or 1080p @ 48 Hz (frame sequential)
720p @ 50/60 Hz (side-by-side half horizontal resolution)	720p @ 50/60 Hz (side-by-side half horizontal resolution)
720p @ 50/60 Hz (top-bottom half vertical resolution)	720p @ 50/60 Hz (top-bottom half vertical resolution)
1080i @ 50/60 Hz (side-by-side half horizontal resolution)	1080p @ 50/60 Hz (side-by-side half horizontal resolution)
1080p @ 50/60 Hz (side-by-side half horizontal resolution)	1080p @ 50/60 Hz (side-by-side half horizontal resolution)
1080p @ 50/60 Hz (top-bottom half vertical resolution)	1080p @ 50/60 Hz (top-bottom half vertical resolution)

2.4 Legacy audio/video interfaces

- 3-inputs of HDMI into a single receiver, with HDCP supporting HD and SD video formats up to 1080p60 (222.75 MHz). HDMI receiver is compliant to v1.4a specification and supports deep color formats, enhanced colorimetry (xvYCC and gamut metadata reception). Supports audio reception in HDMI layout 0 and HDMI layout 1 formats.
- PAL/NTSC/SECAM analog video decoder
- PAL/NTSC/SECAM digital video encoder
- Two 10-bit DACs for S-Video/composite analog video output (SD formats up to 480i/576i)

- Integrated 2-ch, 16-bit audio ADC
- Integrated 6-ch, 24-bit audio DACs
- 3.1-channel Audio PCM Output Interface
- SPDIF input and output
- SCART input and output

2.5 Transport

- Dual transport stream inputs
- Multi-stream transport stream de-multiplexing, dual-tuner DVR, watch/record capable
- Glueless interface to DVB-CI/DVB-CI+/MCARD modules

2.6 Processors and memory

- High-performance dual ST40 CPUs for applications and real-time control
 - ST40@450 MHz, dual-issue, applications CPU, 32KI, 32KD caches deliver > 800 DMIPs
- 2 x 16-bit DDR2/DDR3 Local Memory Interface (LMI), up to 1066 Mbps
- Support for NAND Flash and Quad Speed Serial Flash
- Dual multi-channel, flexible DMA controllers

2.7 Connectivity

- USB 2.0 host interface, with one PHY
- Integrated 10/100 Ethernet MAC/MII/RMII
- SD/MMC card interface

2.8 DVR

- DVR support, with HDD attachment through USB or Flash drive
- DVB/3DES/AES/Multi-2/ARC4 descrambling and support for Hash functions

2.9 Security

- Advanced security management with secure boot and trusted processor
- Broadcast stream encryption management (CI/CI+/MCARD) and DVR data re-encryption
- Fully supports DRMs, including HDCP, WMDRM, DTCP-IP
- Rovi™ copy protection support

2.10 TV SoC peripherals

- Three UARTs
- Three SSC/I2C
- GPIO banks with alternate functions
- Infrared receiver
- Four PWMs
- HDMI CEC
- Low bandwidth ADC for chassis control

2.11 Package

- FPGBA 35 mm x 35 mm, 956 balls, R34x34, Pitch 1.0 mm, Ball 0.6 mm

3 Application overview

Figure 1. EU/US DTT + cable iDTV application

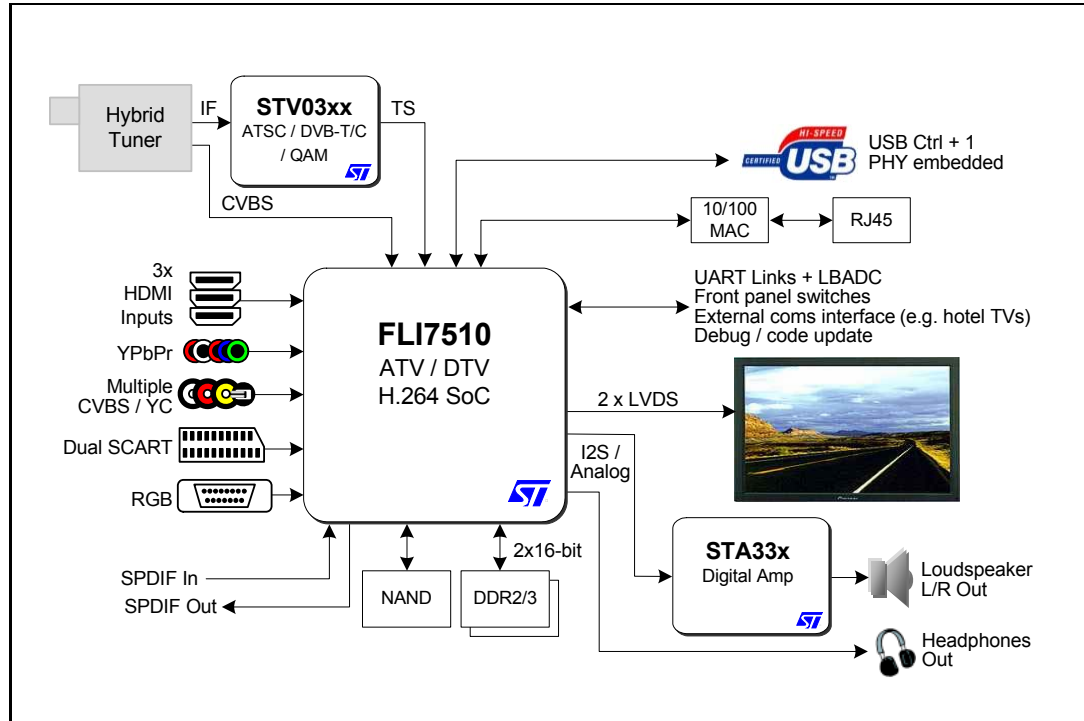

4 Ordering information

Table 2. Order codes

Part number	Description
FLI7510	FPBGA 35 x 35 mm

In order to meet environmental requirements, ST offers these devices in different grades of ECOPACK® packages, depending on their level of environmental compliance. ECOPACK® specifications, grade definitions and product status are available at: www.st.com. ECOPACK® is an ST trademark.

5 Revision history

Table 3. Document revision history

Date	Revision	Changes
08-Dec-2009	1	Initial release.
10-Mar-2010	2	Added support for 3DTV
17-May-2010	3	Updated Table 1 supported formats for HDMI 1.4a Minor updates to section 2.4: Changed section heading, added 576i to 10-bit DACs, moved Rovi copy protection to section 2.9
28-May-2010	4	Updated cover page figure and Section 2.10 TV SoC peripherals (Smart Card references provisionally removed)
13-Jul-2010	5	Added Freeman Lite to cover page title Updated sec 2.2 physical graphics planes Updated sec 2.3 3DTV/3D video intro paragraph
13-Aug-2010	6	Moved Freeman Lite to first description line on cover page
14-Oct-2010	7	Updated Table 1, 3D video formats supported
15-Nov-2010	8	Updated sec 2.9, removed Dwight Cavendish support
08-Jun-2011	9	Changed ST40 CPU bullet on cover page to 1600 DMIPS

Please Read Carefully:

Information in this document is provided solely in connection with ST products. STMicroelectronics NV and its subsidiaries ("ST") reserve the right to make changes, corrections, modifications or improvements, to this document, and the products and services described herein at any time, without notice.

All ST products are sold pursuant to ST's terms and conditions of sale.

Purchasers are solely responsible for the choice, selection and use of the ST products and services described herein, and ST assumes no liability whatsoever relating to the choice, selection or use of the ST products and services described herein.

No license, express or implied, by estoppel or otherwise, to any intellectual property rights is granted under this document. If any part of this document refers to any third party products or services it shall not be deemed a license grant by ST for the use of such third party products or services, or any intellectual property contained therein or considered as a warranty covering the use in any manner whatsoever of such third party products or services or any intellectual property contained therein.

UNLESS OTHERWISE SET FORTH IN ST'S TERMS AND CONDITIONS OF SALE ST DISCLAIMS ANY EXPRESS OR IMPLIED WARRANTY WITH RESPECT TO THE USE AND/OR SALE OF ST PRODUCTS INCLUDING WITHOUT LIMITATION IMPLIED WARRANTIES OF MERCHANTABILITY, FITNESS FOR A PARTICULAR PURPOSE (AND THEIR EQUIVALENTS UNDER THE LAWS OF ANY JURISDICTION), OR INFRINGEMENT OF ANY PATENT, COPYRIGHT OR OTHER INTELLECTUAL PROPERTY RIGHT.

UNLESS EXPRESSLY APPROVED IN WRITING BY AN AUTHORIZED ST REPRESENTATIVE, ST PRODUCTS ARE NOT RECOMMENDED, AUTHORIZED OR WARRANTED FOR USE IN MILITARY, AIR CRAFT, SPACE, LIFE SAVING, OR LIFE SUSTAINING APPLICATIONS, NOR IN PRODUCTS OR SYSTEMS WHERE FAILURE OR MALFUNCTION MAY RESULT IN PERSONAL INJURY, DEATH, OR SEVERE PROPERTY OR ENVIRONMENTAL DAMAGE. ST PRODUCTS WHICH ARE NOT SPECIFIED AS "AUTOMOTIVE GRADE" MAY ONLY BE USED IN AUTOMOTIVE APPLICATIONS AT USER'S OWN RISK.

Resale of ST products with provisions different from the statements and/or technical features set forth in this document shall immediately void any warranty granted by ST for the ST product or service described herein and shall not create or extend in any manner whatsoever, any liability of ST.

ST and the ST logo are trademarks or registered trademarks of ST in various countries.

Information in this document supersedes and replaces all information previously supplied.

The ST logo is a registered trademark of STMicroelectronics. All other names are the property of their respective owners.

© 2011 STMicroelectronics - All rights reserved

STMicroelectronics group of companies

Australia - Belgium - Brazil - Canada - China - Czech Republic - Finland - France - Germany - Hong Kong - India - Israel - Italy - Japan - Malaysia - Malta - Morocco - Philippines - Singapore - Spain - Sweden - Switzerland - United Kingdom - United States of America

www.st.com