



STEVAL-ICB004V1

Advanced resistive touchscreen controller demonstration board based on the STMPE811

Data brief

Features

- Four-wire resistive touch-sensing demonstration GUI
- Configurable touch-sensing parameters
- STMPE811 GPIO expander functionality hardware support
- Hardware configurable jumper headers offer freedom for easy interfacing of touchscreen controller in user designs
- USB universal dongle functionality for STM32 microcontroller SPI and I²C interfaces
- Run-time application firmware upgrade using DFU
- RoHS compliant



Description

The STEVAL-ICB004V1 board demonstrates the high-speed resistive touch-sensing functionality of the STMPE811 advanced resistive touchscreen controller. The board offers the added functionality of a USB universal dongle for I²C and SPI interfaces, and DFU (device firmware upgrade) protocol for run-time firmware upgrades. The STEVAL-ICB004V1 includes the STMPE811 demonstration GUI software (for Windows[®] XP) to capture writing/drawing events on the touchscreen. The board also includes an additional UUSCI (universal USB-to-serial communication interface) GUI for evaluation of different I²C and SPI sensors, and a DFU GUI for run-time firmware upgrades. The many functions integrated in this single board render the STEVAL-ICB004V1 a multi-purpose demonstration platform for evaluating the STMPE811 advanced touchscreen controller.

1 Schematic diagrams

Figure 1. Touchscreen controller

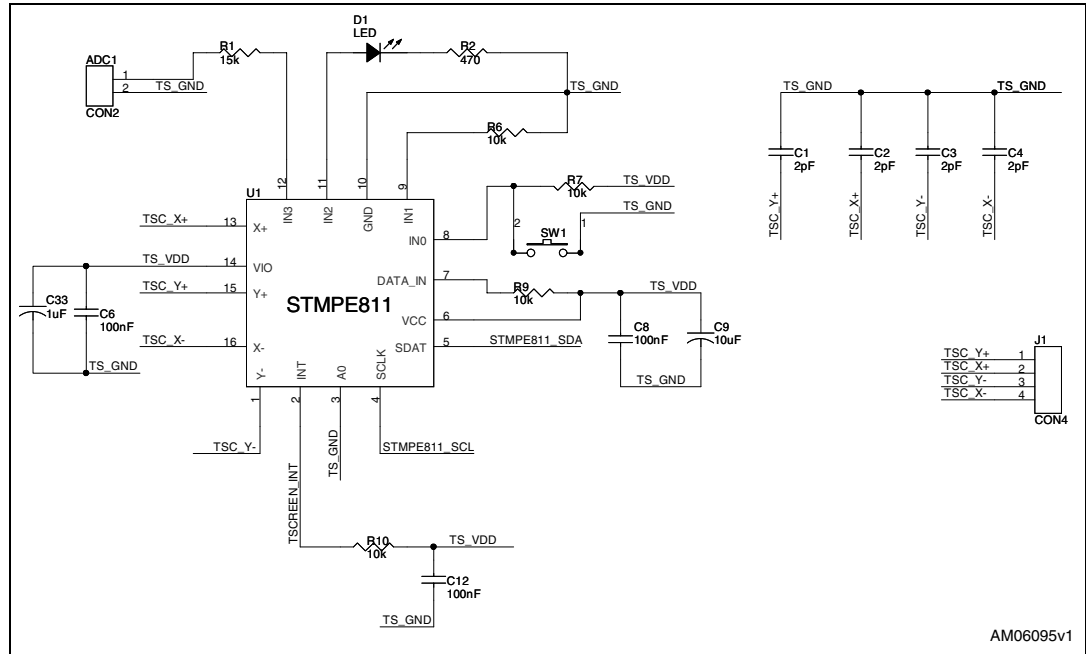

Figure 2. Microcontroller section

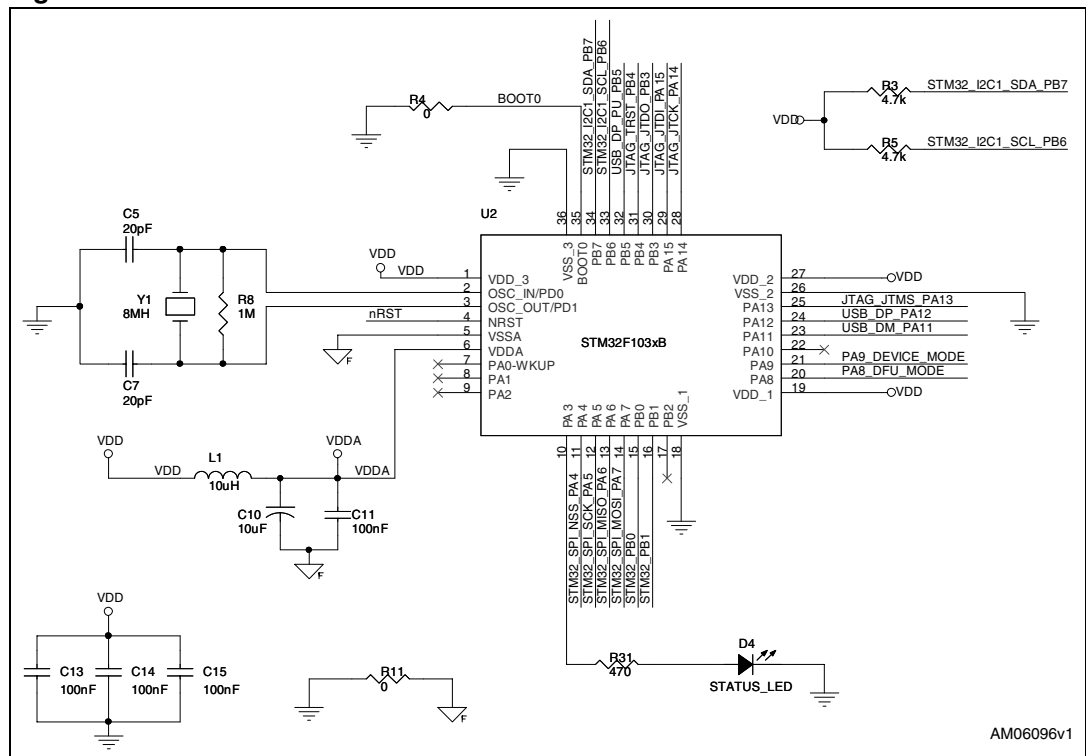

Figure 3. JTAG connector

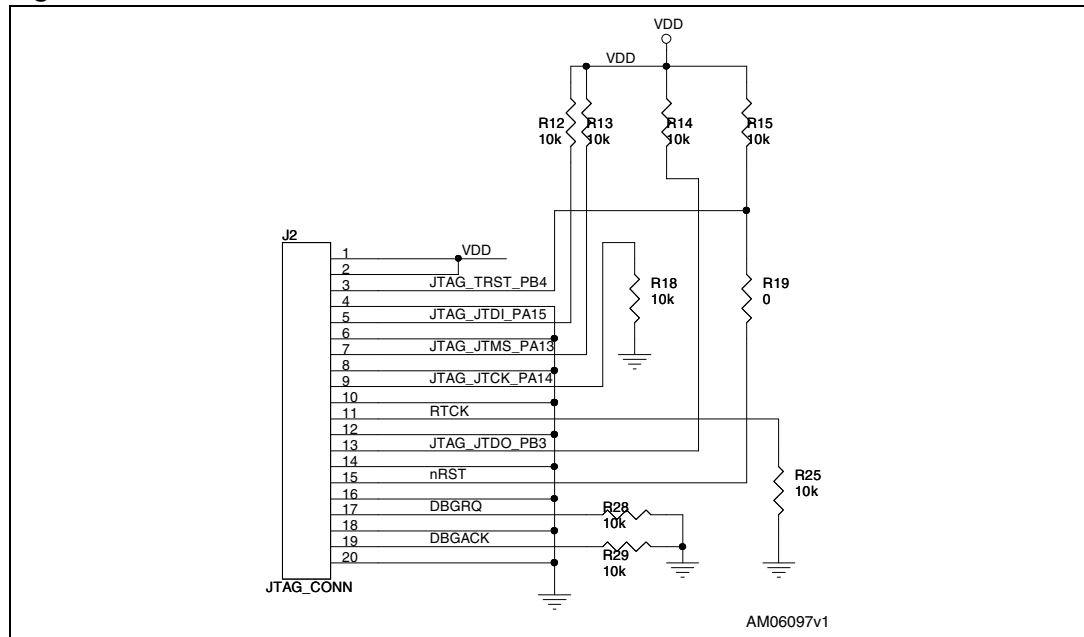

Figure 4. Voltage regulator section

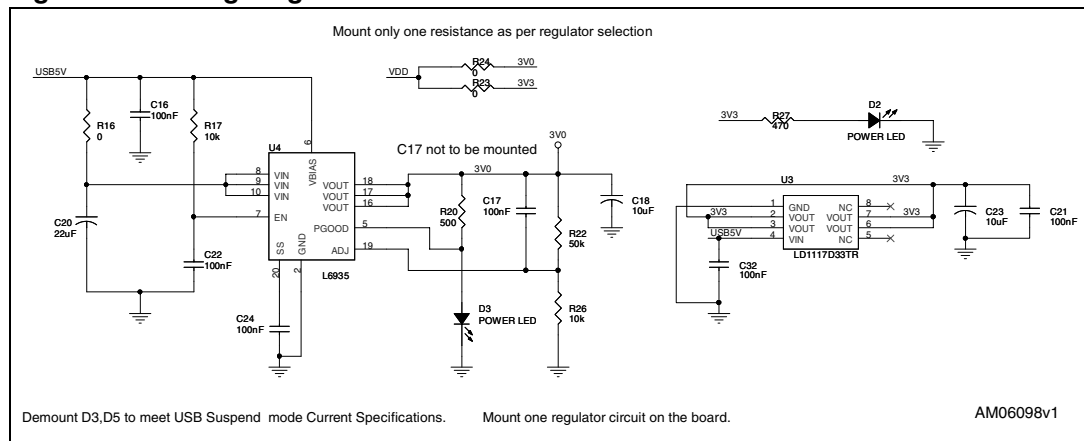

Figure 5. Connectors section

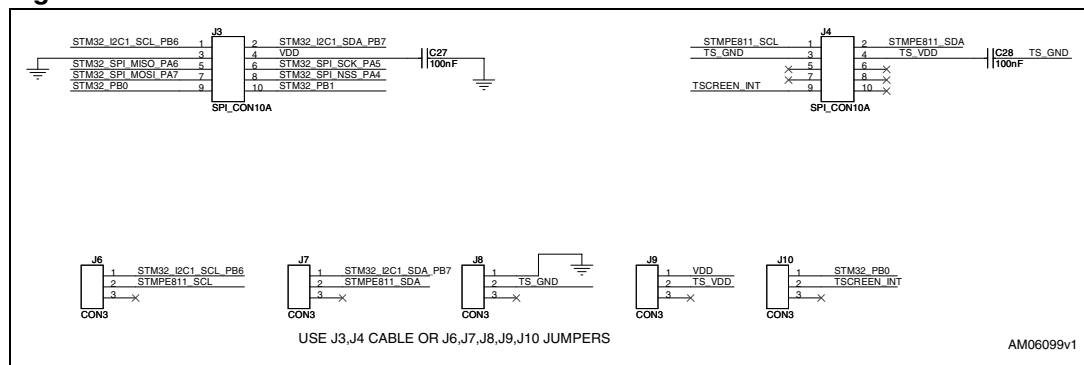

Figure 6. USB section

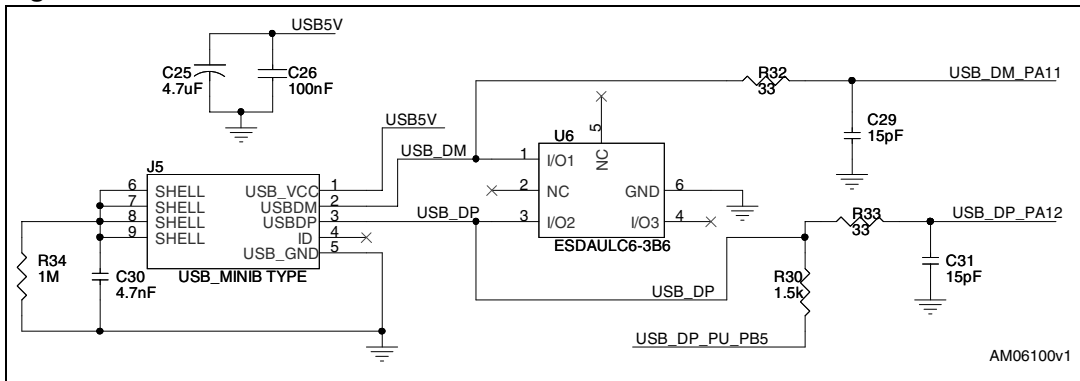

Figure 7. Reset section

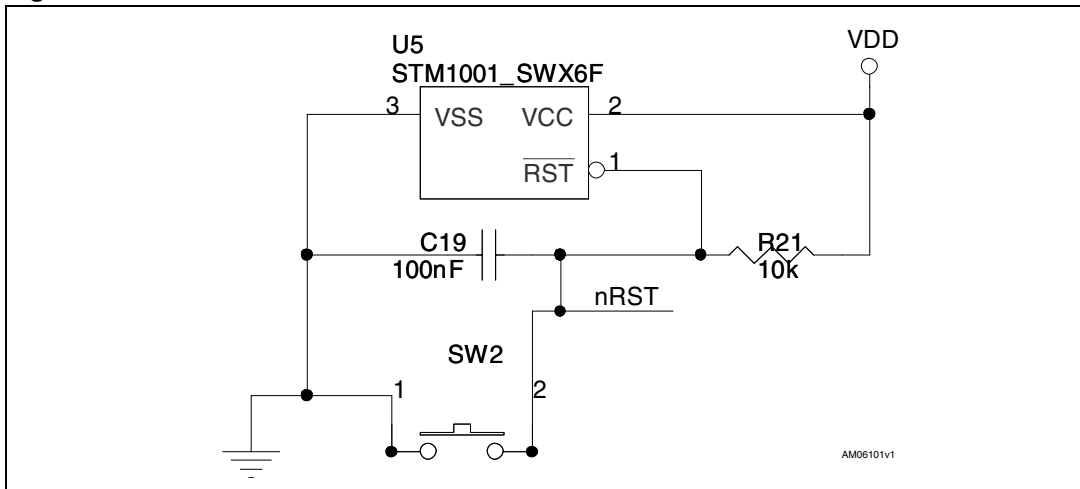
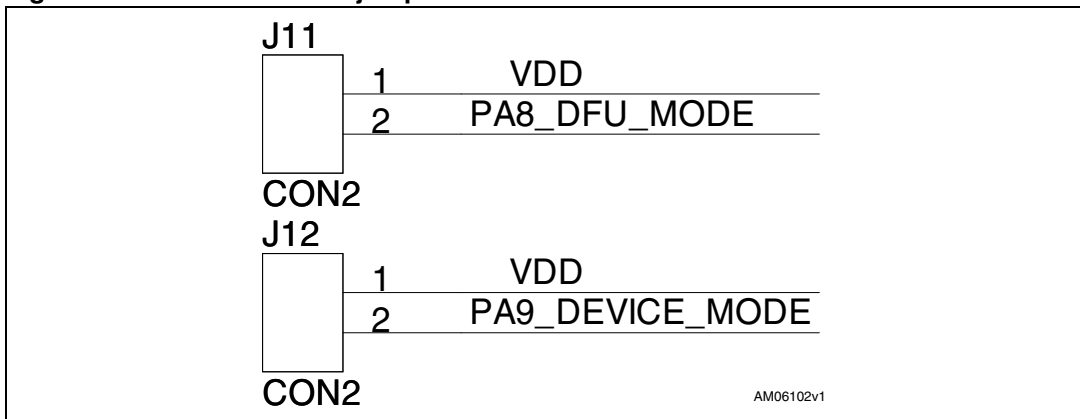

Figure 8. Mode selection jumpers



2 Revision history

Table 1. Document revision history

Date	Revision	Changes
23-Feb-2011	1	Initial release.

Please Read Carefully:

Information in this document is provided solely in connection with ST products. STMicroelectronics NV and its subsidiaries ("ST") reserve the right to make changes, corrections, modifications or improvements, to this document, and the products and services described herein at any time, without notice.

All ST products are sold pursuant to ST's terms and conditions of sale.

Purchasers are solely responsible for the choice, selection and use of the ST products and services described herein, and ST assumes no liability whatsoever relating to the choice, selection or use of the ST products and services described herein.

No license, express or implied, by estoppel or otherwise, to any intellectual property rights is granted under this document. If any part of this document refers to any third party products or services it shall not be deemed a license grant by ST for the use of such third party products or services, or any intellectual property contained therein or considered as a warranty covering the use in any manner whatsoever of such third party products or services or any intellectual property contained therein.

UNLESS OTHERWISE SET FORTH IN ST'S TERMS AND CONDITIONS OF SALE ST DISCLAIMS ANY EXPRESS OR IMPLIED WARRANTY WITH RESPECT TO THE USE AND/OR SALE OF ST PRODUCTS INCLUDING WITHOUT LIMITATION IMPLIED WARRANTIES OF MERCHANTABILITY, FITNESS FOR A PARTICULAR PURPOSE (AND THEIR EQUIVALENTS UNDER THE LAWS OF ANY JURISDICTION), OR INFRINGEMENT OF ANY PATENT, COPYRIGHT OR OTHER INTELLECTUAL PROPERTY RIGHT.

UNLESS EXPRESSLY APPROVED IN WRITING BY AN AUTHORIZED ST REPRESENTATIVE, ST PRODUCTS ARE NOT RECOMMENDED, AUTHORIZED OR WARRANTED FOR USE IN MILITARY, AIR CRAFT, SPACE, LIFE SAVING, OR LIFE SUSTAINING APPLICATIONS, NOR IN PRODUCTS OR SYSTEMS WHERE FAILURE OR MALFUNCTION MAY RESULT IN PERSONAL INJURY, DEATH, OR SEVERE PROPERTY OR ENVIRONMENTAL DAMAGE. ST PRODUCTS WHICH ARE NOT SPECIFIED AS "AUTOMOTIVE GRADE" MAY ONLY BE USED IN AUTOMOTIVE APPLICATIONS AT USER'S OWN RISK.

Resale of ST products with provisions different from the statements and/or technical features set forth in this document shall immediately void any warranty granted by ST for the ST product or service described herein and shall not create or extend in any manner whatsoever, any liability of ST.

ST and the ST logo are trademarks or registered trademarks of ST in various countries.

Information in this document supersedes and replaces all information previously supplied.

The ST logo is a registered trademark of STMicroelectronics. All other names are the property of their respective owners.

© 2011 STMicroelectronics - All rights reserved

STMicroelectronics group of companies

Australia - Belgium - Brazil - Canada - China - Czech Republic - Finland - France - Germany - Hong Kong - India - Israel - Italy - Japan - Malaysia - Malta - Morocco - Philippines - Singapore - Spain - Sweden - Switzerland - United Kingdom - United States of America

www.st.com