

STMicroelectronics		
Title: SPIRIT1-Development Kit		
Size: B	Document Number: 01-2011	Rev: B.1
Date: Friday, November 18, 2011	Sheet: 1	of 11

MOTHERBOARD

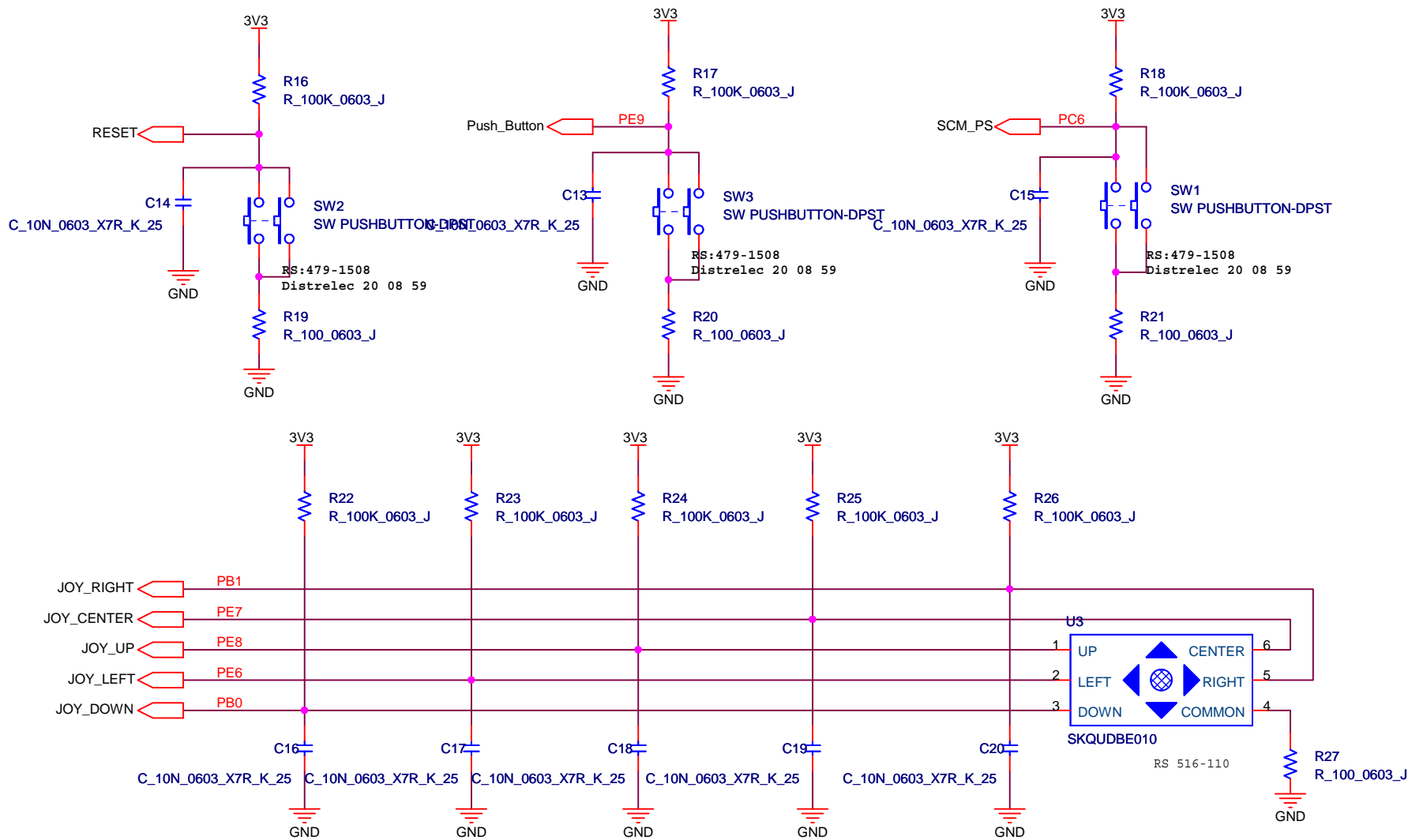

Title		
Buttons & Joystick		
Size	Document Number	Rev
A	<Doc>	B.1
Date:	Friday, November 18, 2011	Sheet 3 of 11

MOTHERBOARD

www.BDTIC.com/ST

JTAG/SWD

ST Link: 3.0-3.6V, 5V tolerant
IAR J-Link: 1.2-3.6V, 5V tolerant

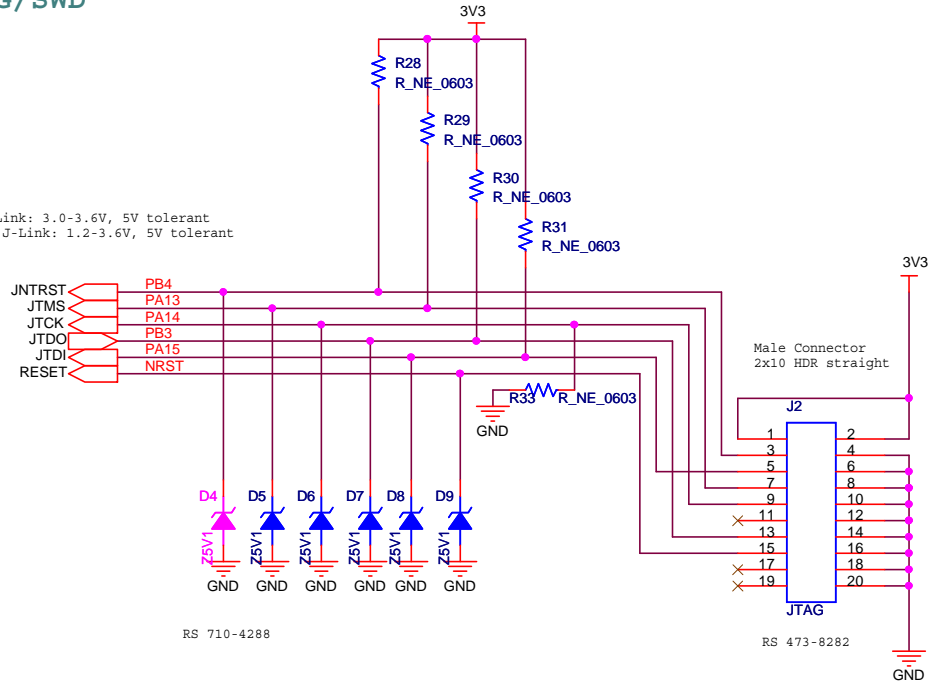

USB

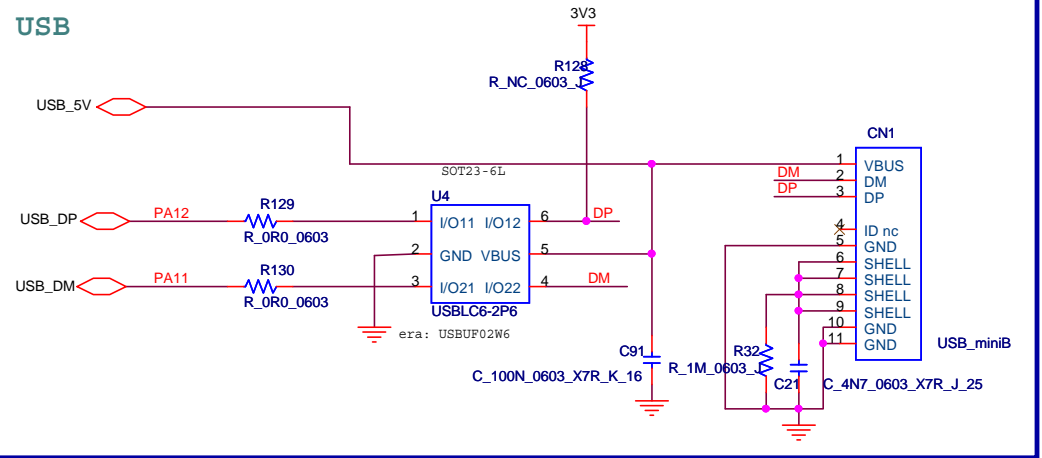

BNC

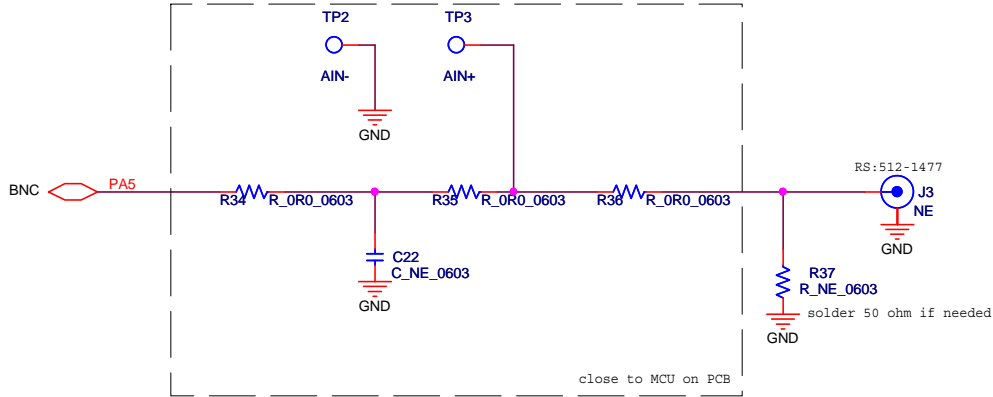

Title		Interface	
Size	Document Number	Rev	
Custom<Doc>		<RevCode>	
Date:	Monday, November 21, 2011	Sheet	4 of 11

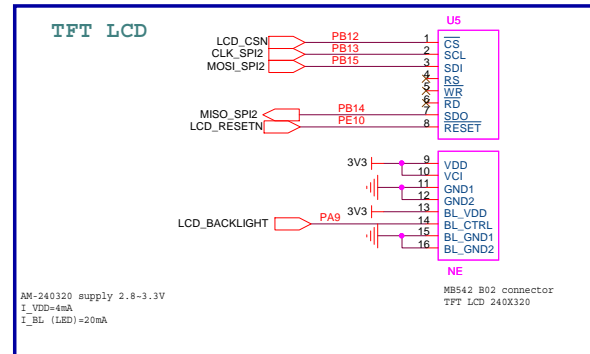
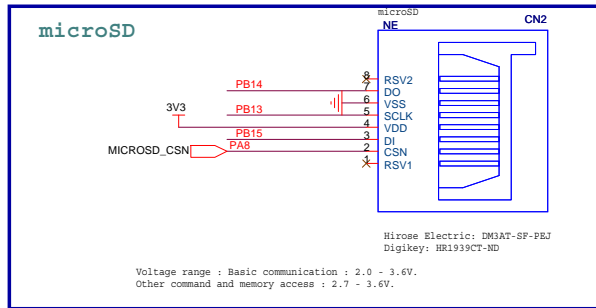

Title	LCD-SDA_Card	
Size	Document Number	Rev
B	<Doc>	<Rev Code>
Date:	Monday, November 07, 2011	Sheet 5 of 11

MOTHERBOARD

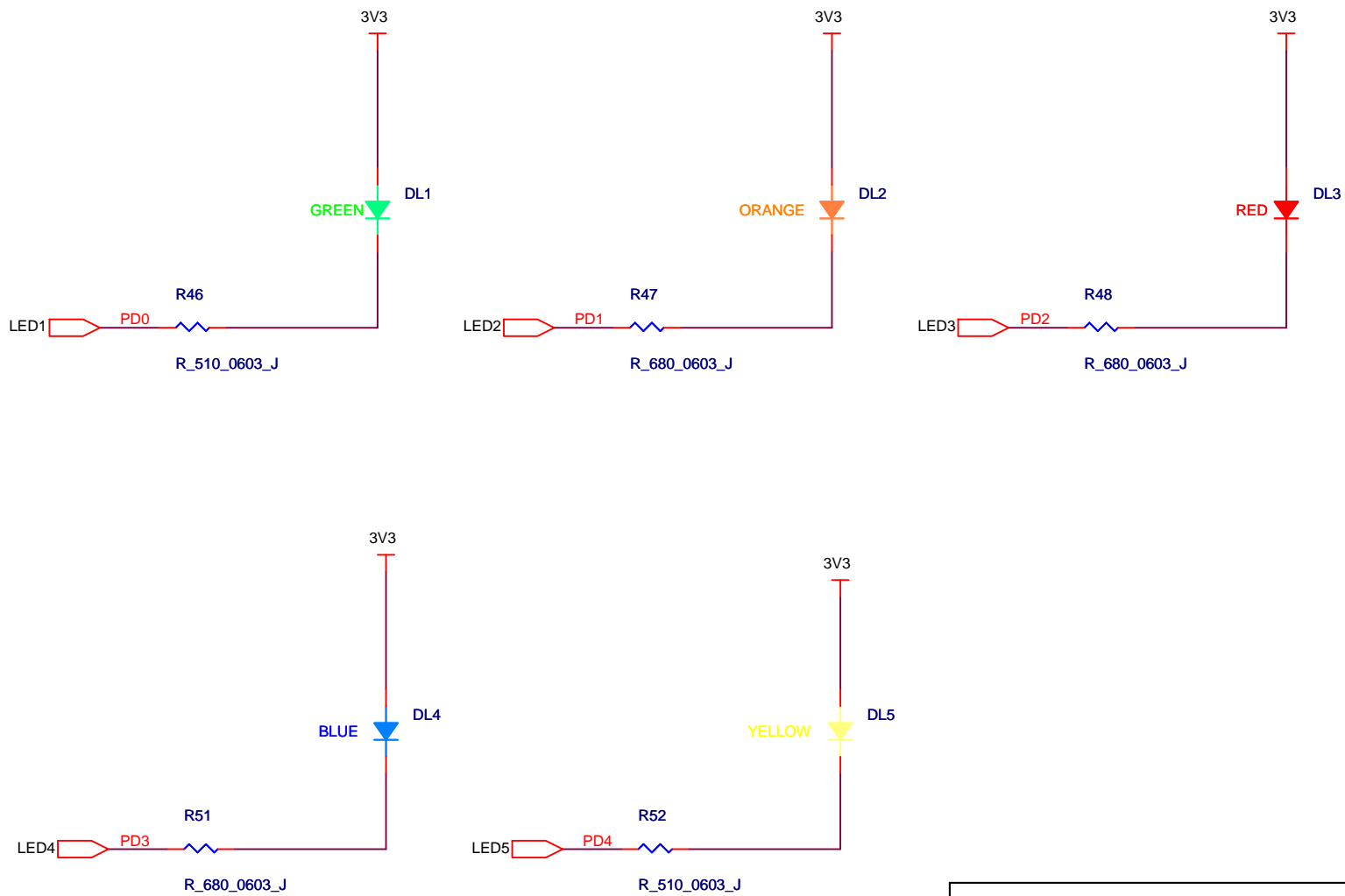

Title		
LEDS		
Size	Document Number	Rev
A	<Doc>	<RevCode>
Date:	Monday, November 07, 2011	Sheet 6 of 11

MOTHERBOARD

www.BDTIC.com/ST

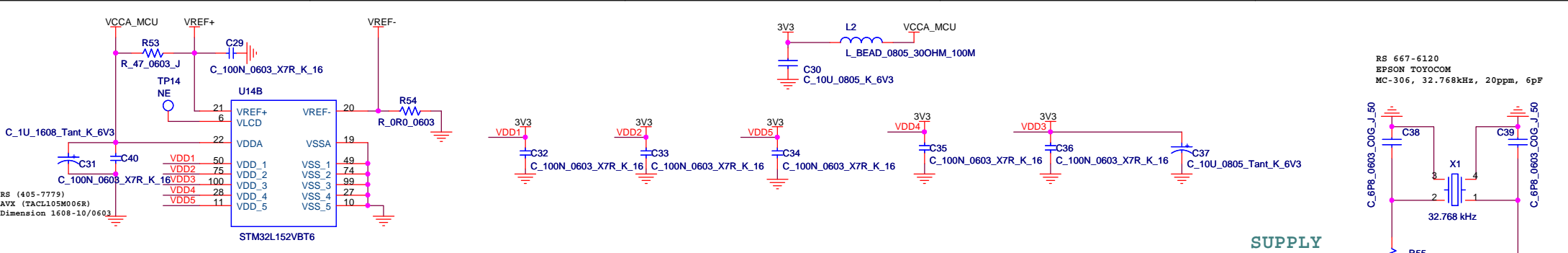

RS (405-7779)
AVX (TAACL105M06R)
Dimension 1608-10/0603

RS 667-6120
EPSON TOYOCON
MC-306, 32.768kHz, 20ppm, 6pF

SUPPLY

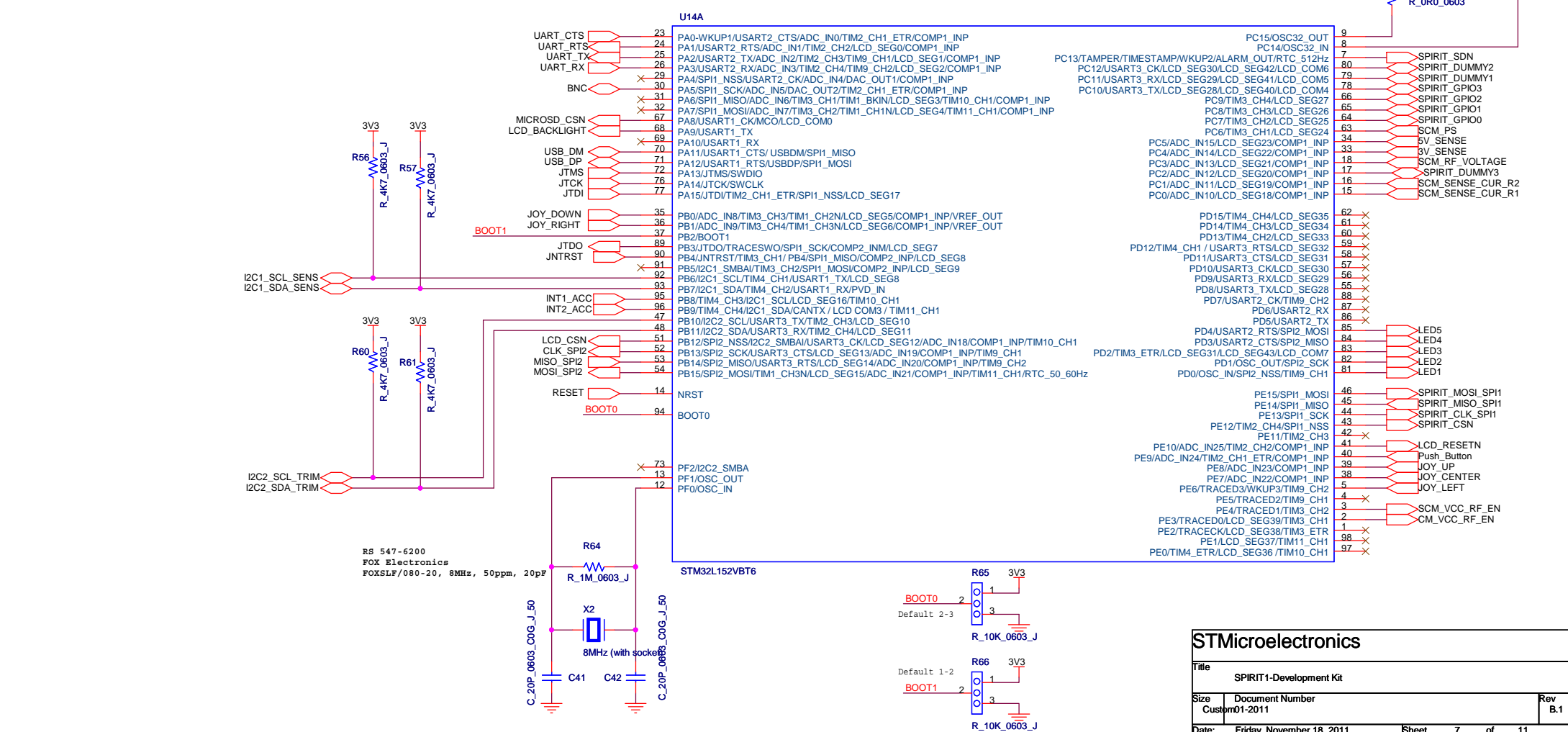

RS 547-6200
FOX Electronics
FOXSLF/080-20, 8MHz, 50ppm, 20pF

STMicroelectronics		
Title SPIRIT1-Development Kit		
Size	Document Number	Rev
Custom	01-2011	B.1
Date:	Friday, November 18, 2011	Sheet 7 of 11

1.8V - 3.6V Power Management with 110dB current range measurement

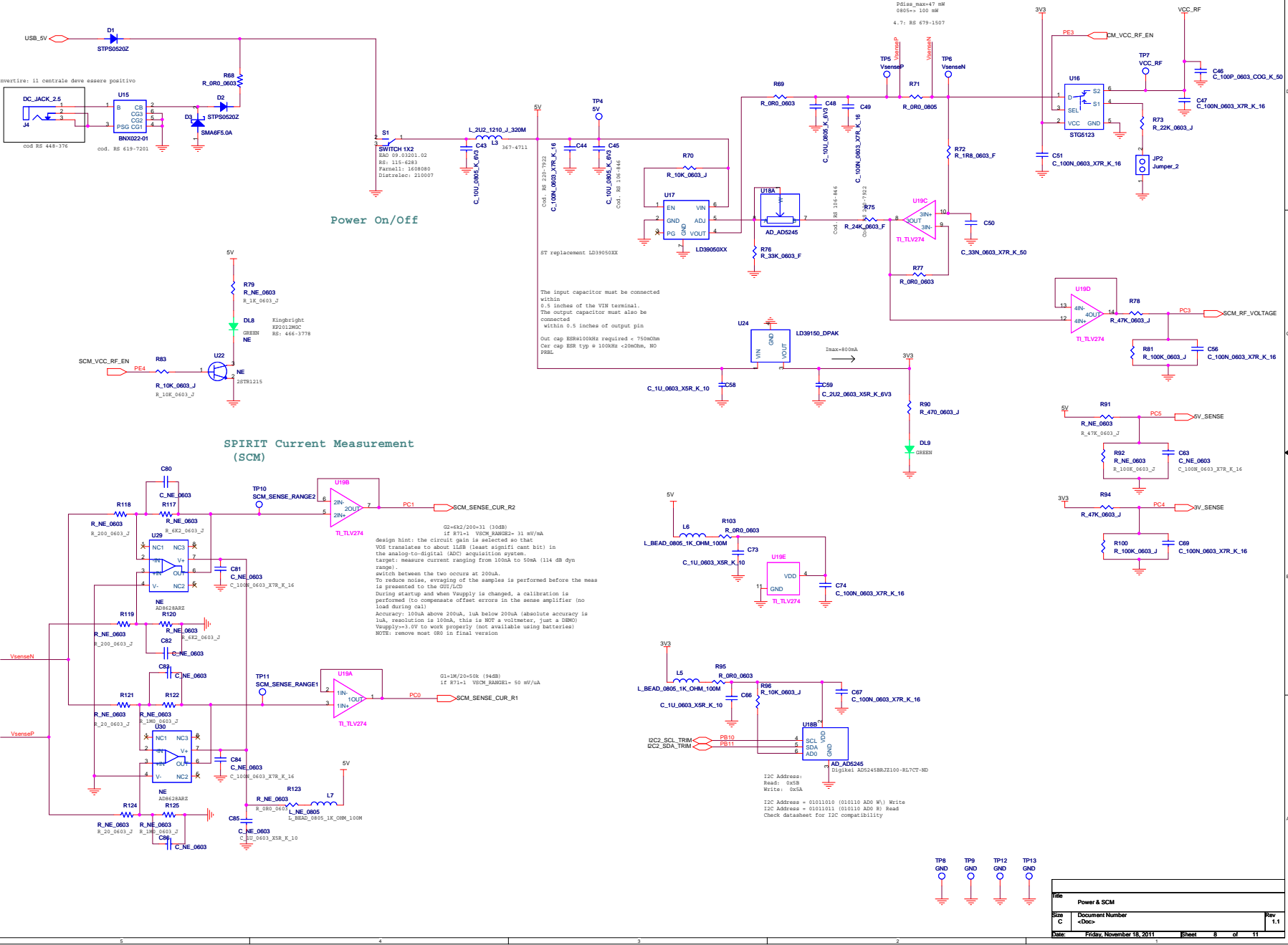

Power On/Off

SPIRIT Current Measurement (SCM)

ST replacement LD39050X

The input capacitor must be connected within 0.5 inches of the VIN terminal. The output capacitor must also be connected within 0.5 inches of output pin

Our cap 88k100nM required = 75000nM
Our cap 88k typ = 1000nM < 200nM, NO PREL

design hint: the circuit gain is selected so that VOS translates to about 1LSB (least signif cant bit) in the analog-to-digital (ADC) acquisition system.

target: measure current ranging from 100nA to 100uA (114 dB dyn range).

switch between the two occurs at 200uA.

To reduce noise, averaging of the samples is performed before the meas is presented to the GSI/DCI

During startup and when Vsupply is changed, a calibration is performed (to compensate offset errors in the sense amplifier (no load during cal))

Accuracy: 100nA above 200uA, 1uA below 200uA (absolute accuracy is 1uA, resolution is 100nA, this is NOT a voltmeter, just a DMM)

Vsupply > 3.0V to work properly (not available using batteries)

NOTE: remove most 000 in final version

I2C Address: Digital AD52458BZ100-RL7CT-MD
Read: 0x38
Write: 0x3A

I2C Address = 0101010 (010110 ADD W) Write
I2C Address = 0101011 (010110 ADD R) Read
Check datasheet for I2C compatibility

Title		Power & SCM
Size	Document Number	Rev
C	<Doc>	1.1
Date	Friday, November 18, 2011	Sheet 8 of 11

MOTHERBOARD

www.BDTIC.com/ST

Tantalum AVX ESR max at 100 kHz = 6 Ohm
 Ceramic Cap 0805 10uF 6V3 ESR typ at 100 kHz=0.1 Ohm!!!

Accelerometer LIS331DLH

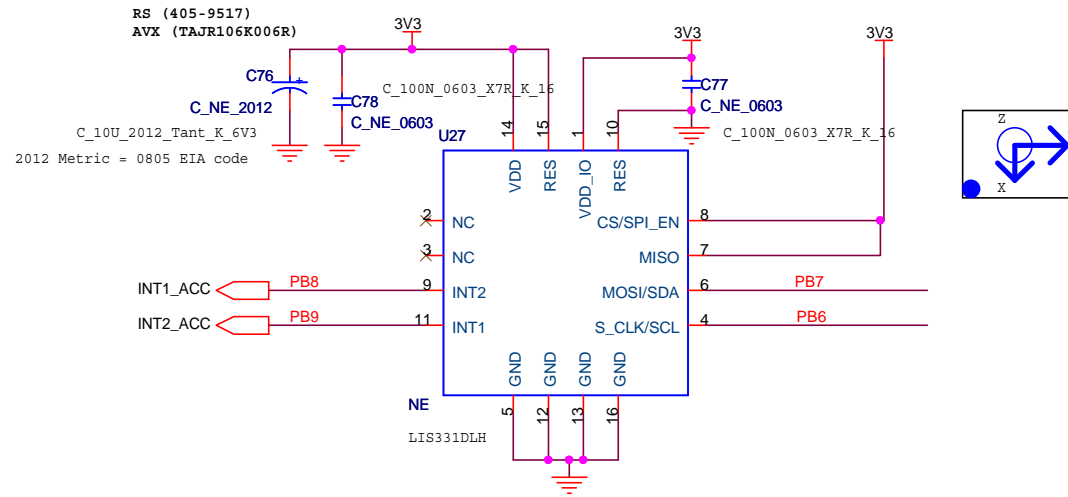

The Slave Address (SAD) associated to the LIS331DLH is 001100xb. SDO/SA0 pad can be used to modify less significant bit of the device address. If SA0 pad is connected to voltage supply, LSB is '1' (address 0011001b) else if SA0 pad is connected to ground, LSB value is '0' (address 0011000b). This solution permits to connect and address two different accelerometers to the same I2C lines.

Temperature Sensor

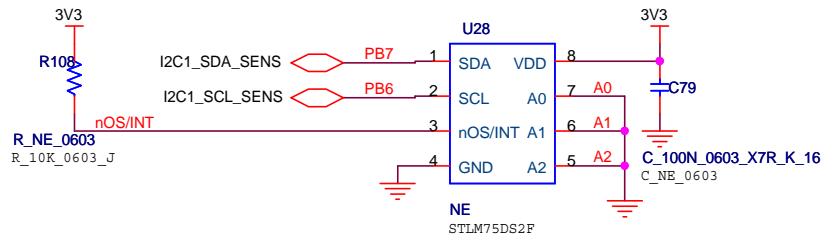

I2C Address:
 Read: 0x91
 Write: 0x90

I2C Address = 10010000 (1001A2A1A0W) Write
 I2C Address = 10010001 (1001A2A1A0R) Read

Title			Sensing		
Size	Document Number	Rev			
Custom	<Doc>	<RevCo			
Date:	Friday, November 18, 2011	Sheet	10	of	11

SPIRIT AND EXTENSION CONNECTORS

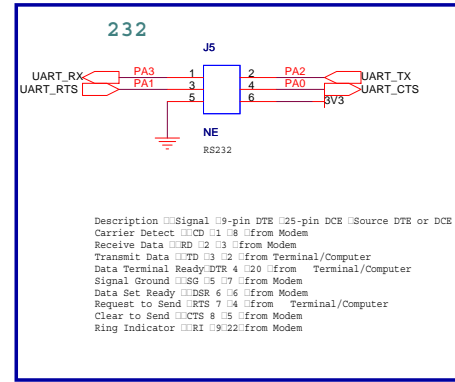
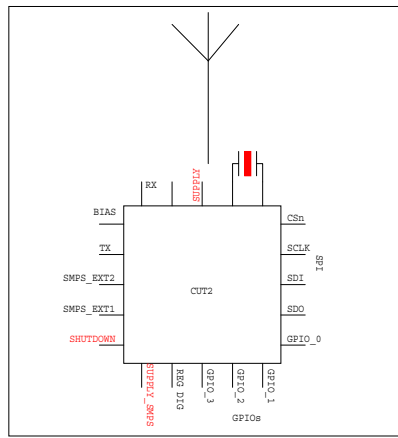

Gradconn BB02-KY102-K03-A00000

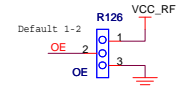
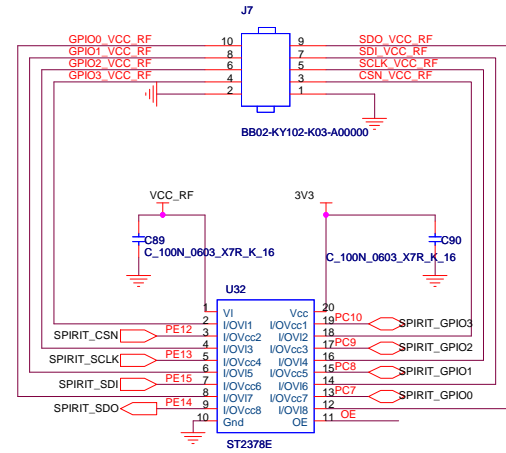
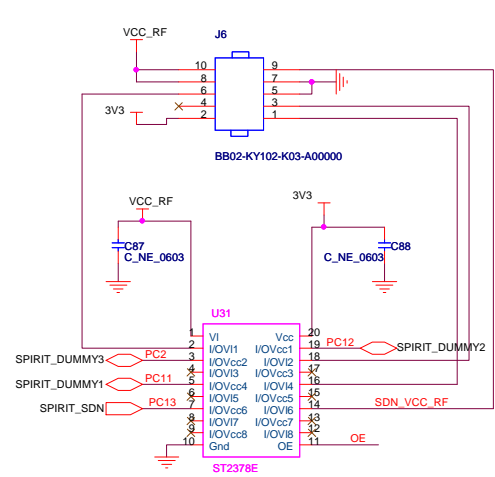
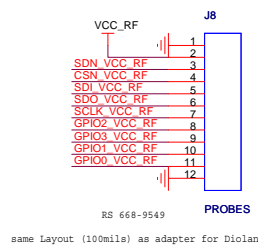

LEVEL TRASLATOR

Title		
SPIRIT AND EXTENSION CONNECTORS		
Size	Document Number	Rev
B	<Doc>	1
Date:	Friday, November 18, 2011	Sheet 11 of 11

MOTHERBOARD

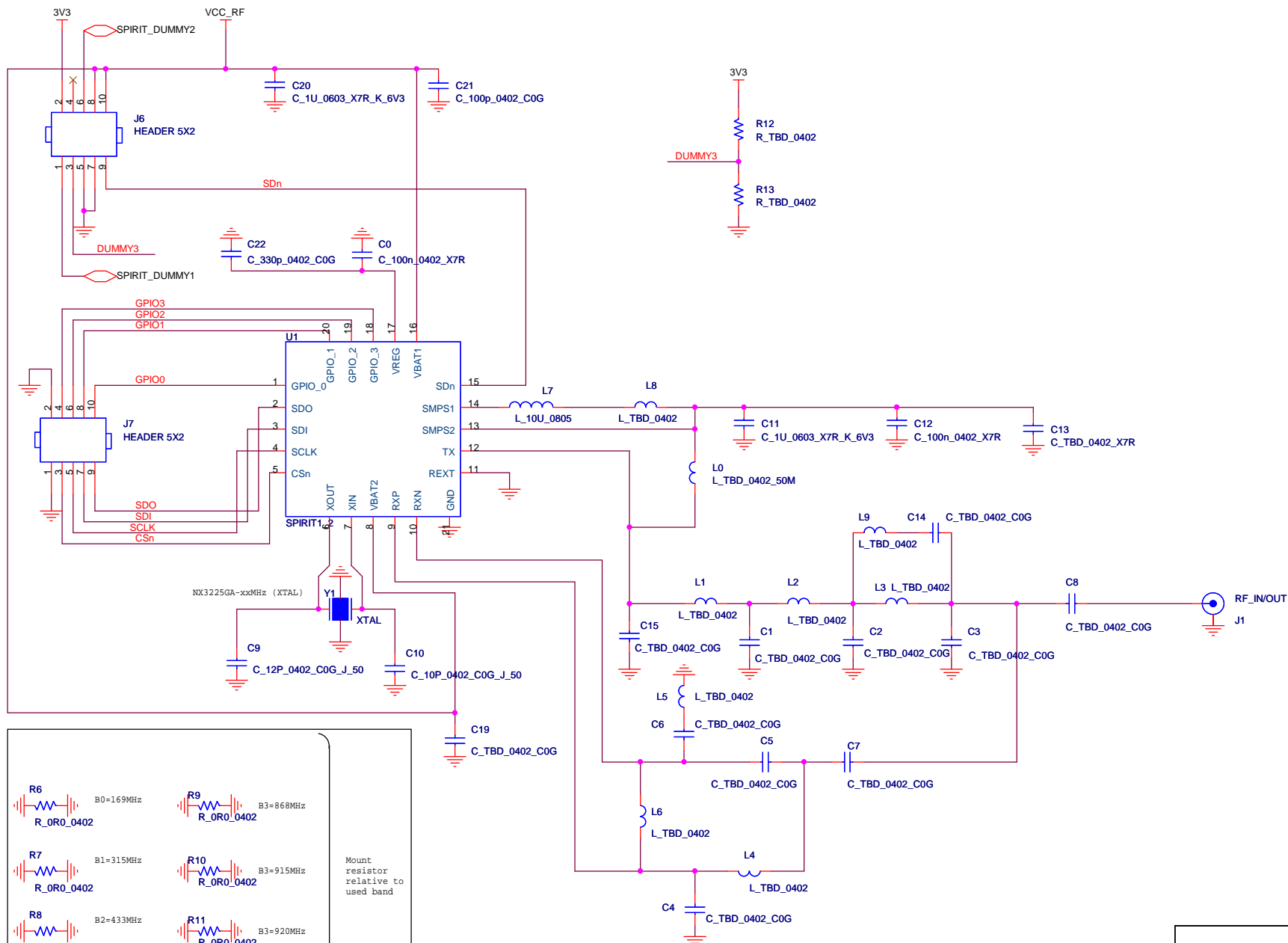

R6 R_0R0_0402 B0=169MHz	R9 R_0R0_0402 B3=868MHz	Mount resistor relative to used band
R7 R_0R0_0402 B1=315MHz	R10 R_0R0_0402 B3=915MHz	
R8 R_0R0_0402 B2=433MHz	R11 R_0R0_0402 B3=920MHz	

Title SPIRIT1 RF PCB		
Size B	Document Number 1.0	Rev 1.0
Date: Monday, May 07, 2012	Sheet 1	of 1