



STEVAL-ISB007V1

Low cost Li-Ion battery charger demonstration board based on the ST7260 and L6924U

Data Brief

Features

- Can be used in USB mode or adapter mode
- LEDs indicate status of charging conditions
- ICC connector available to program the microcontroller
- Li-Ion / Li-Polymer battery charger

Description

The STEVAL-ISB007V1 demonstration board is based on the L6924, a standalone Li-Ion/ Li-Polymer battery charger. Power to the board can be supplied either by USB or an external DC adaptor.

In USB mode, the charging current of the battery complies with high-power USB device specifications. The L6924 is powered by 5 V from the USB, thus also charging the battery.

An ST7260 microcontroller is used for enumeration with the PC, to control the SD pin and to ensure compliance with USB high-power bus-powered specifications.

The board also features a general-purpose adaptor socket for use when the board is powered by an external DC supply. In this case the L6924 is completely independent of the microcontroller.



STEVAL-ISB007V1

1 Circuit schematics

Figure 1. Microcontroller section

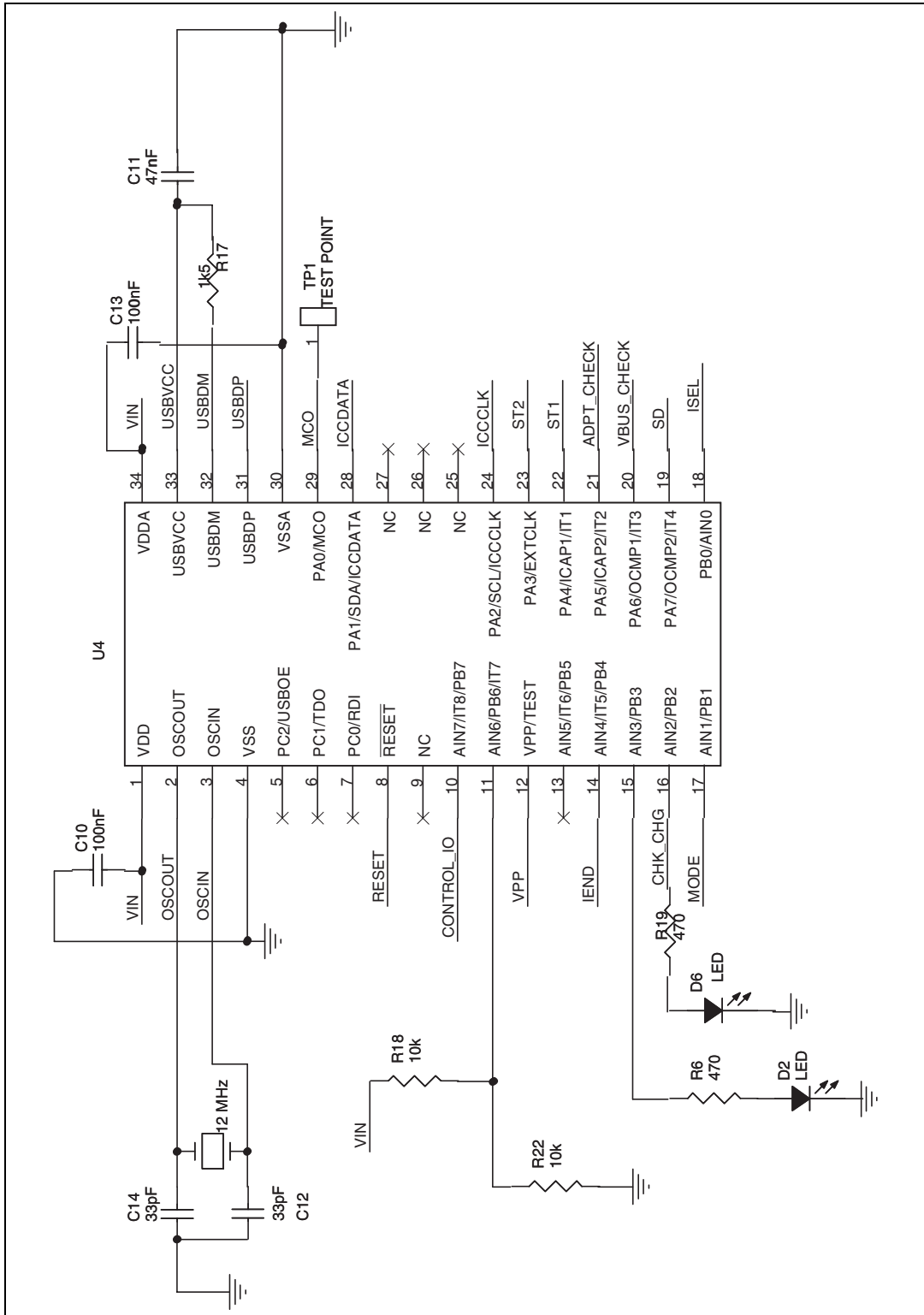
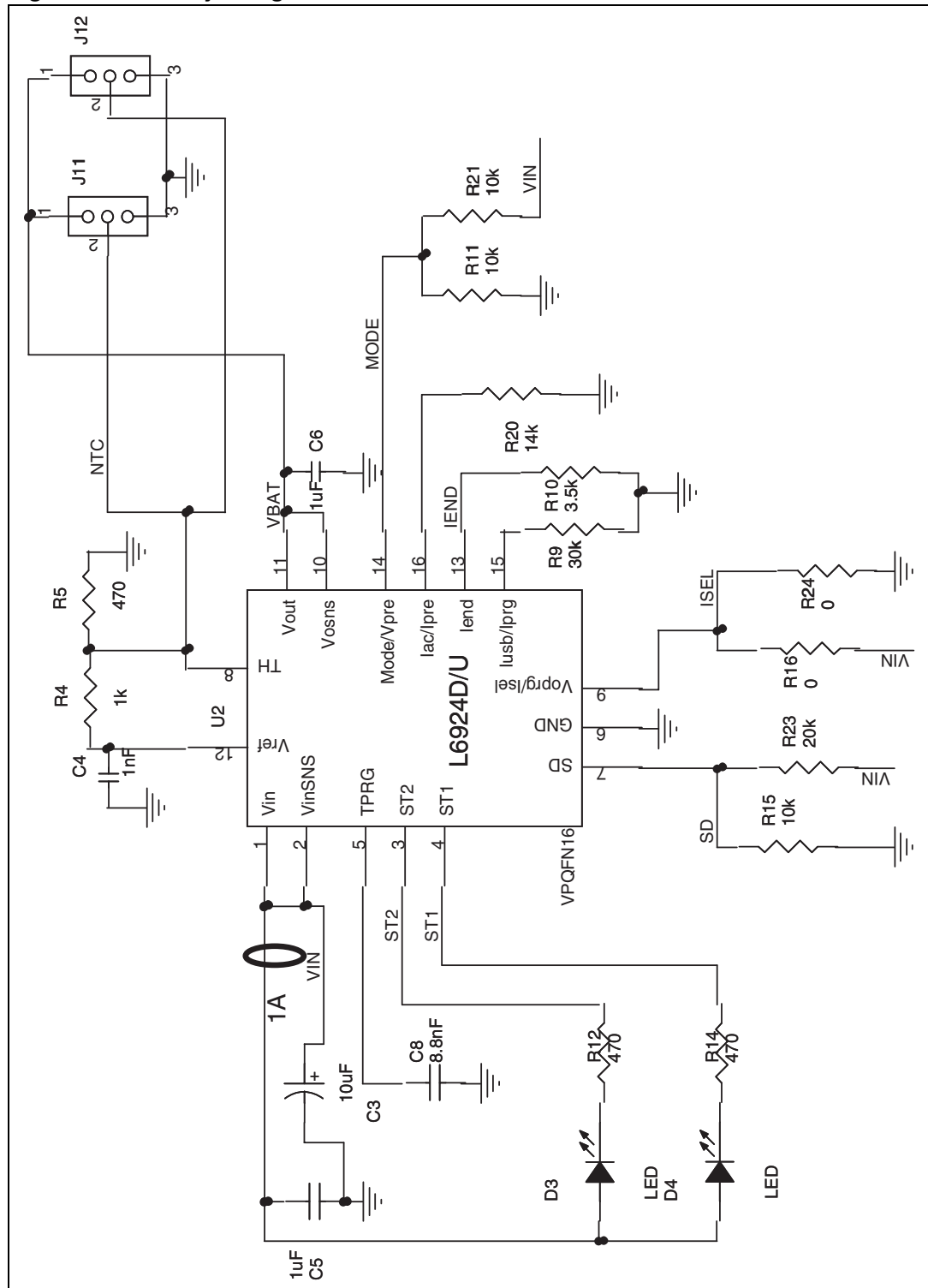

Figure 2. Battery charger⁽¹⁾



1. Pin no.description of L6924 is taken for both L6924D and L6924U.Pls refer to respective datasheets

Figure 3. Power supply

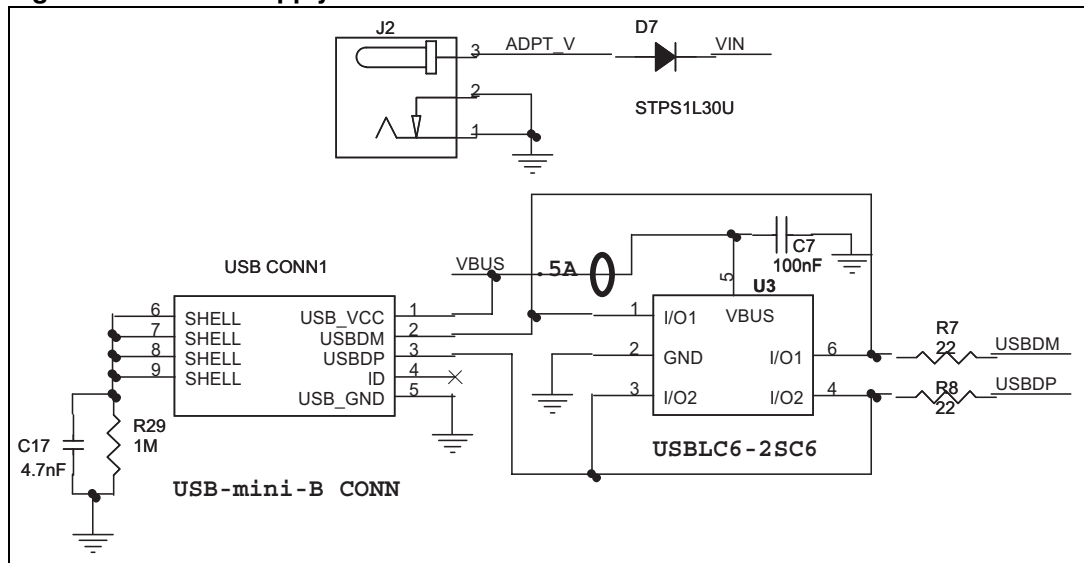

Figure 4. USB-B connector

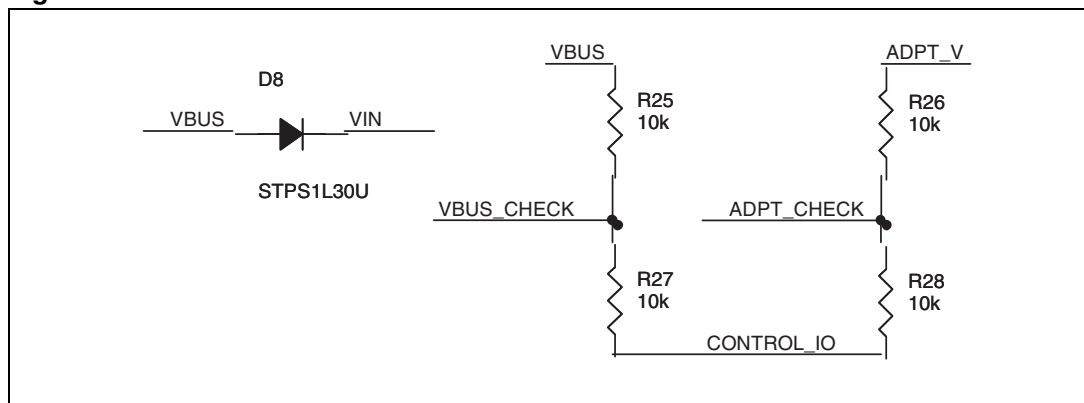
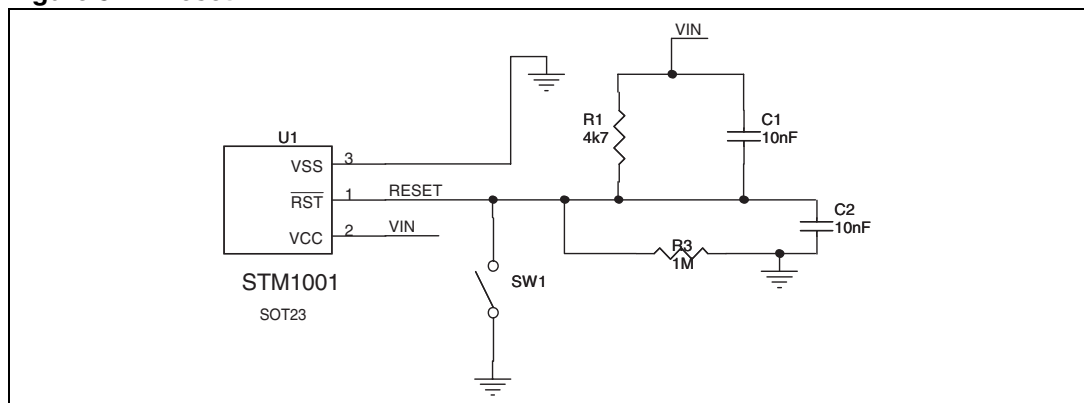

Figure 5. Reset



2 Revision history

Table 1. Document revision history

Date	Revision	Changes
26-Feb-2009	1	Initial release.

Please Read Carefully:

Information in this document is provided solely in connection with ST products. STMicroelectronics NV and its subsidiaries ("ST") reserve the right to make changes, corrections, modifications or improvements, to this document, and the products and services described herein at any time, without notice.

All ST products are sold pursuant to ST's terms and conditions of sale.

Purchasers are solely responsible for the choice, selection and use of the ST products and services described herein, and ST assumes no liability whatsoever relating to the choice, selection or use of the ST products and services described herein.

No license, express or implied, by estoppel or otherwise, to any intellectual property rights is granted under this document. If any part of this document refers to any third party products or services it shall not be deemed a license grant by ST for the use of such third party products or services, or any intellectual property contained therein or considered as a warranty covering the use in any manner whatsoever of such third party products or services or any intellectual property contained therein.

UNLESS OTHERWISE SET FORTH IN ST'S TERMS AND CONDITIONS OF SALE ST DISCLAIMS ANY EXPRESS OR IMPLIED WARRANTY WITH RESPECT TO THE USE AND/OR SALE OF ST PRODUCTS INCLUDING WITHOUT LIMITATION IMPLIED WARRANTIES OF MERCHANTABILITY, FITNESS FOR A PARTICULAR PURPOSE (AND THEIR EQUIVALENTS UNDER THE LAWS OF ANY JURISDICTION), OR INFRINGEMENT OF ANY PATENT, COPYRIGHT OR OTHER INTELLECTUAL PROPERTY RIGHT.

UNLESS EXPRESSLY APPROVED IN WRITING BY AN AUTHORIZED ST REPRESENTATIVE, ST PRODUCTS ARE NOT RECOMMENDED, AUTHORIZED OR WARRANTED FOR USE IN MILITARY, AIR CRAFT, SPACE, LIFE SAVING, OR LIFE SUSTAINING APPLICATIONS, NOR IN PRODUCTS OR SYSTEMS WHERE FAILURE OR MALFUNCTION MAY RESULT IN PERSONAL INJURY, DEATH, OR SEVERE PROPERTY OR ENVIRONMENTAL DAMAGE. ST PRODUCTS WHICH ARE NOT SPECIFIED AS "AUTOMOTIVE GRADE" MAY ONLY BE USED IN AUTOMOTIVE APPLICATIONS AT USER'S OWN RISK.

Resale of ST products with provisions different from the statements and/or technical features set forth in this document shall immediately void any warranty granted by ST for the ST product or service described herein and shall not create or extend in any manner whatsoever, any liability of ST.

ST and the ST logo are trademarks or registered trademarks of ST in various countries.

Information in this document supersedes and replaces all information previously supplied.

The ST logo is a registered trademark of STMicroelectronics. All other names are the property of their respective owners.

© 2009 STMicroelectronics - All rights reserved

STMicroelectronics group of companies

Australia - Belgium - Brazil - Canada - China - Czech Republic - Finland - France - Germany - Hong Kong - India - Israel - Italy - Japan - Malaysia - Malta - Morocco - Singapore - Spain - Sweden - Switzerland - United Kingdom - United States of America

www.st.com