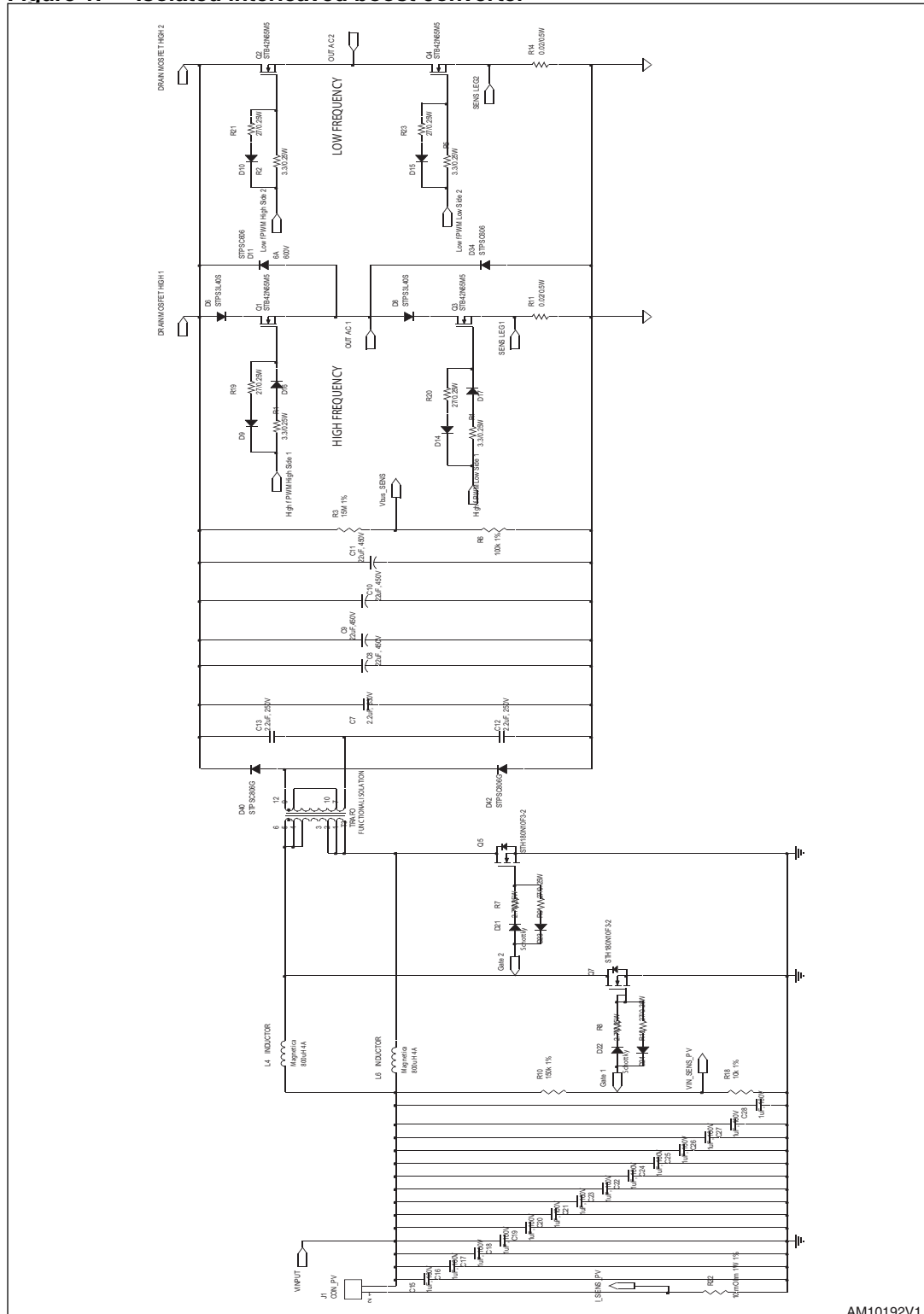
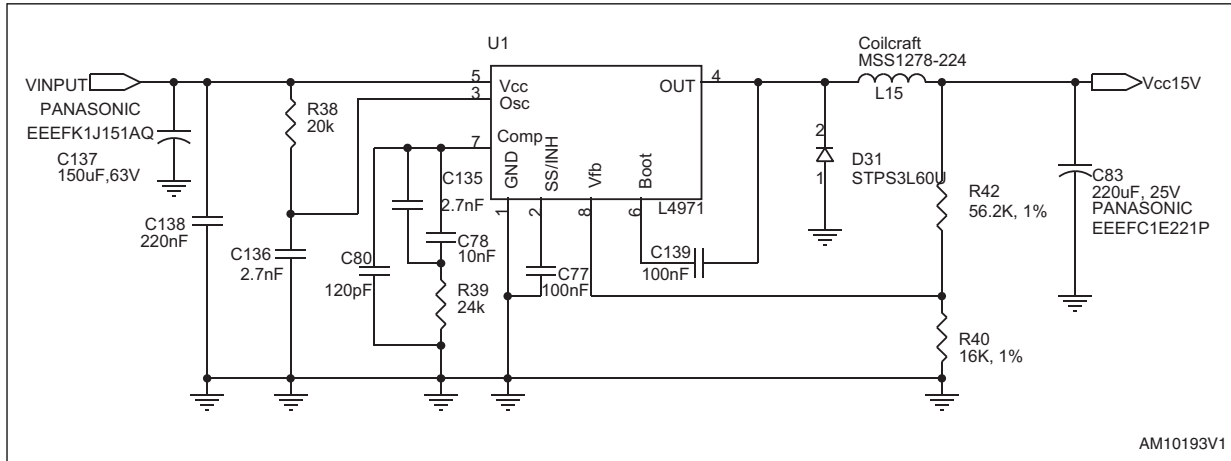

Figure 1. Isolated interleaved boost converter



AM10192V1

**Figure 2. Power supply section - 15 V**



AM10193V1

**Figure 3. Power supply section - 5 V**

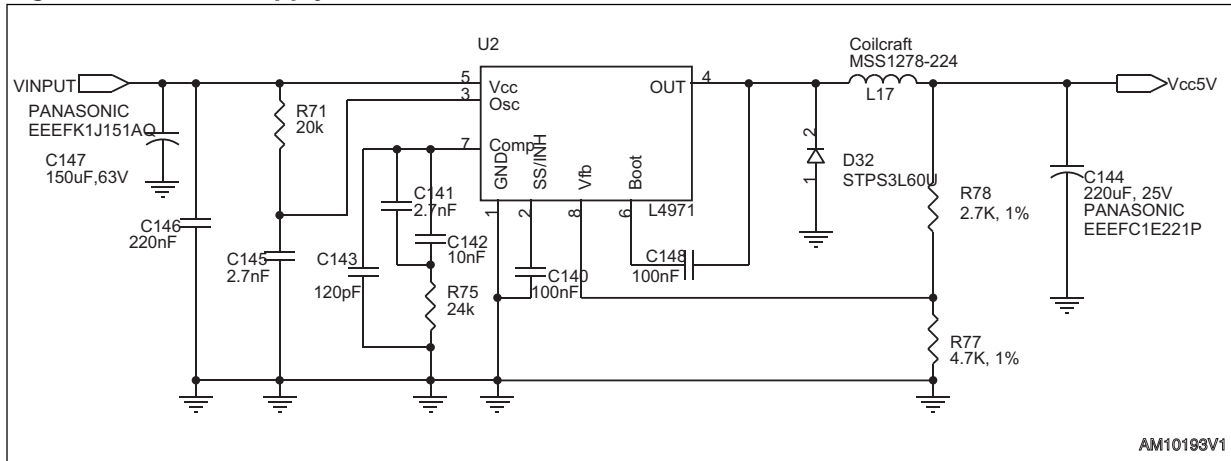

AM10193V1

**Figure 4. DC/DC drive selection**

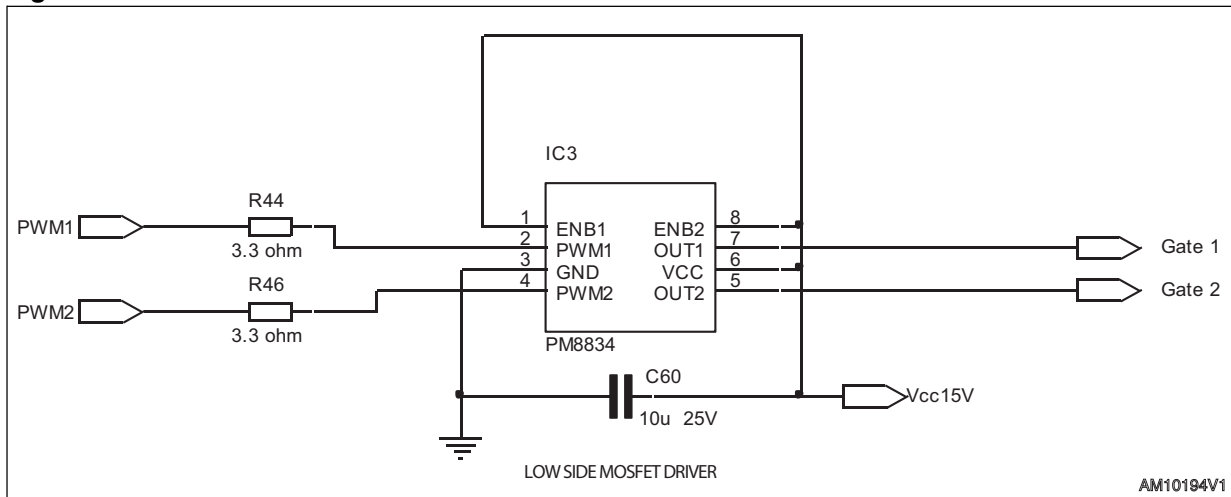

AM10194V1

Figure 5. V-bus sensing

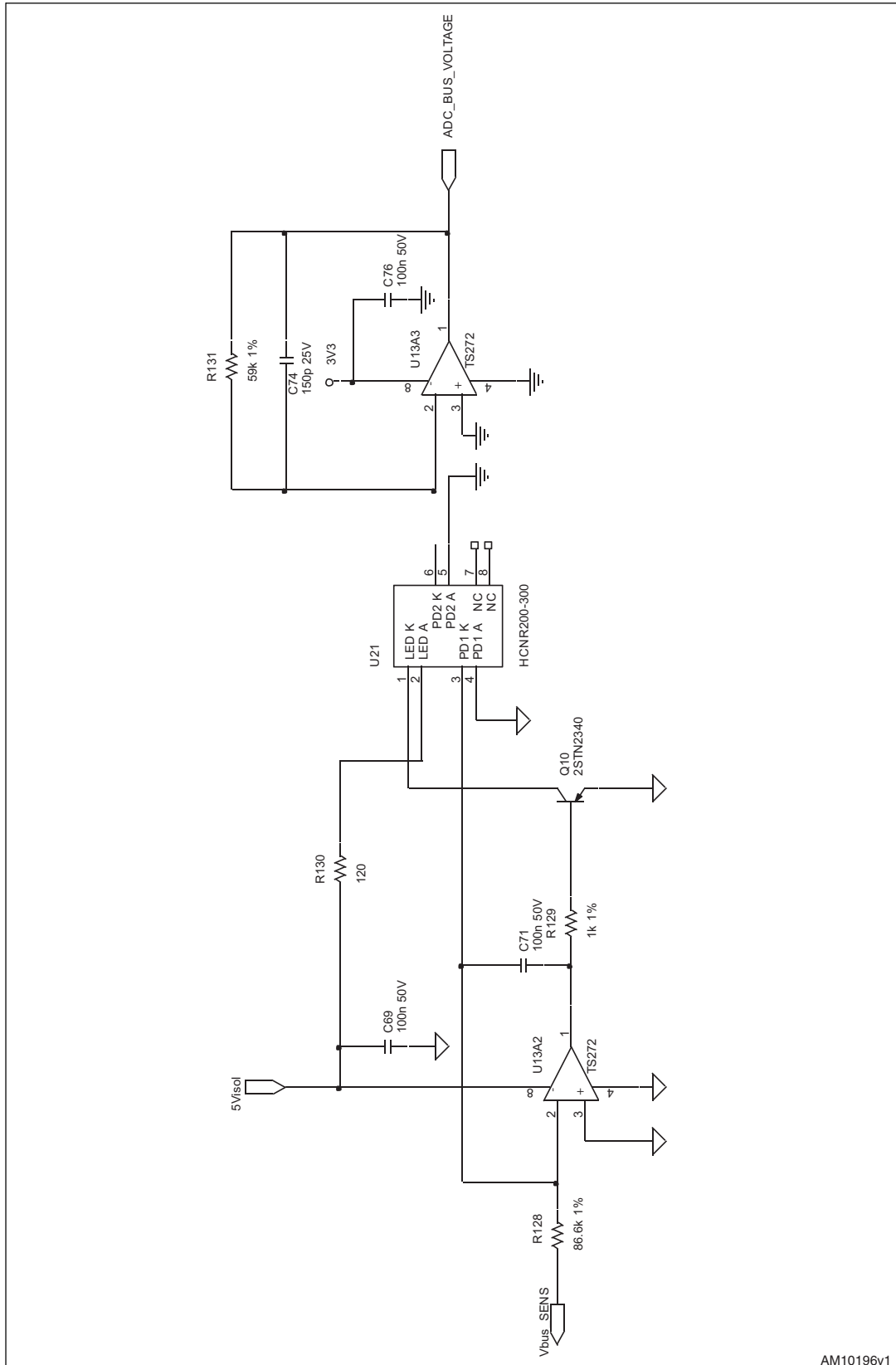

AM10196v1

**Figure 6. 5 V isolated**

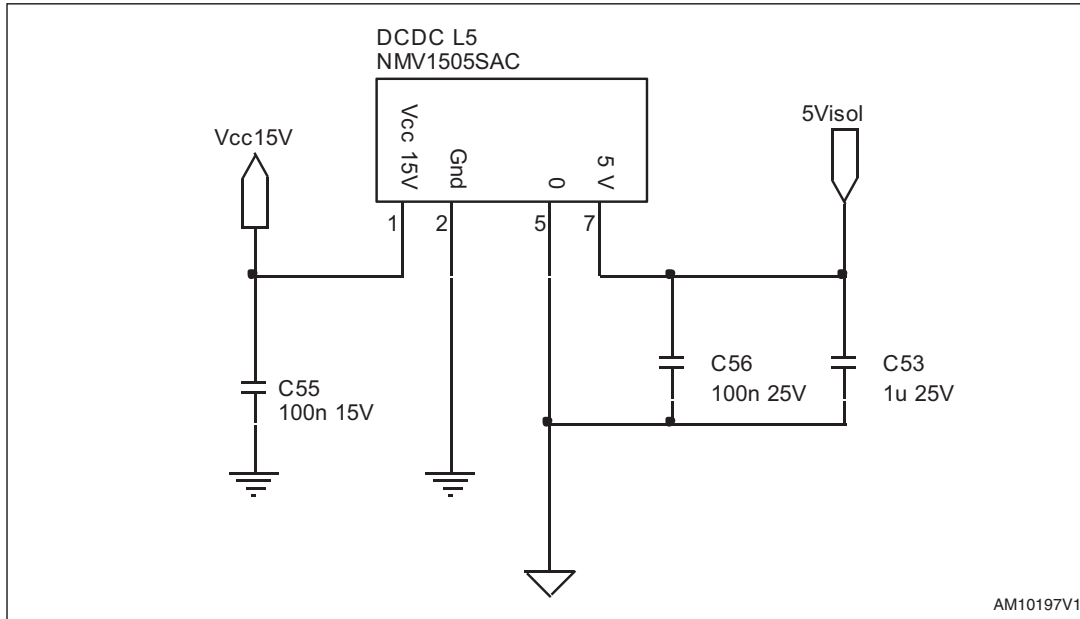

**Figure 7. PV voltage sensing section**

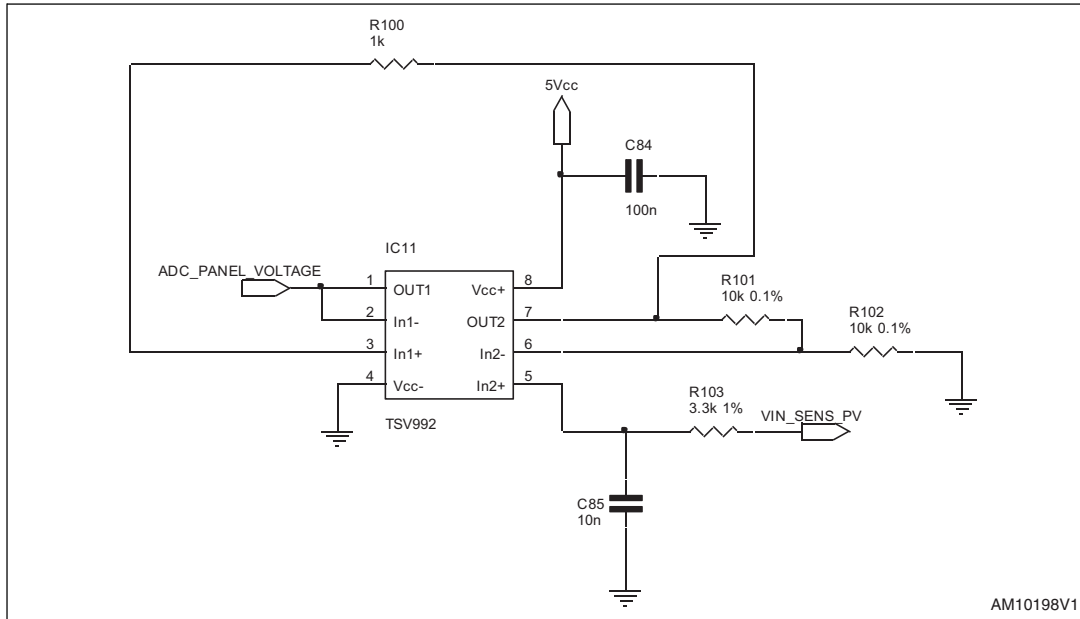
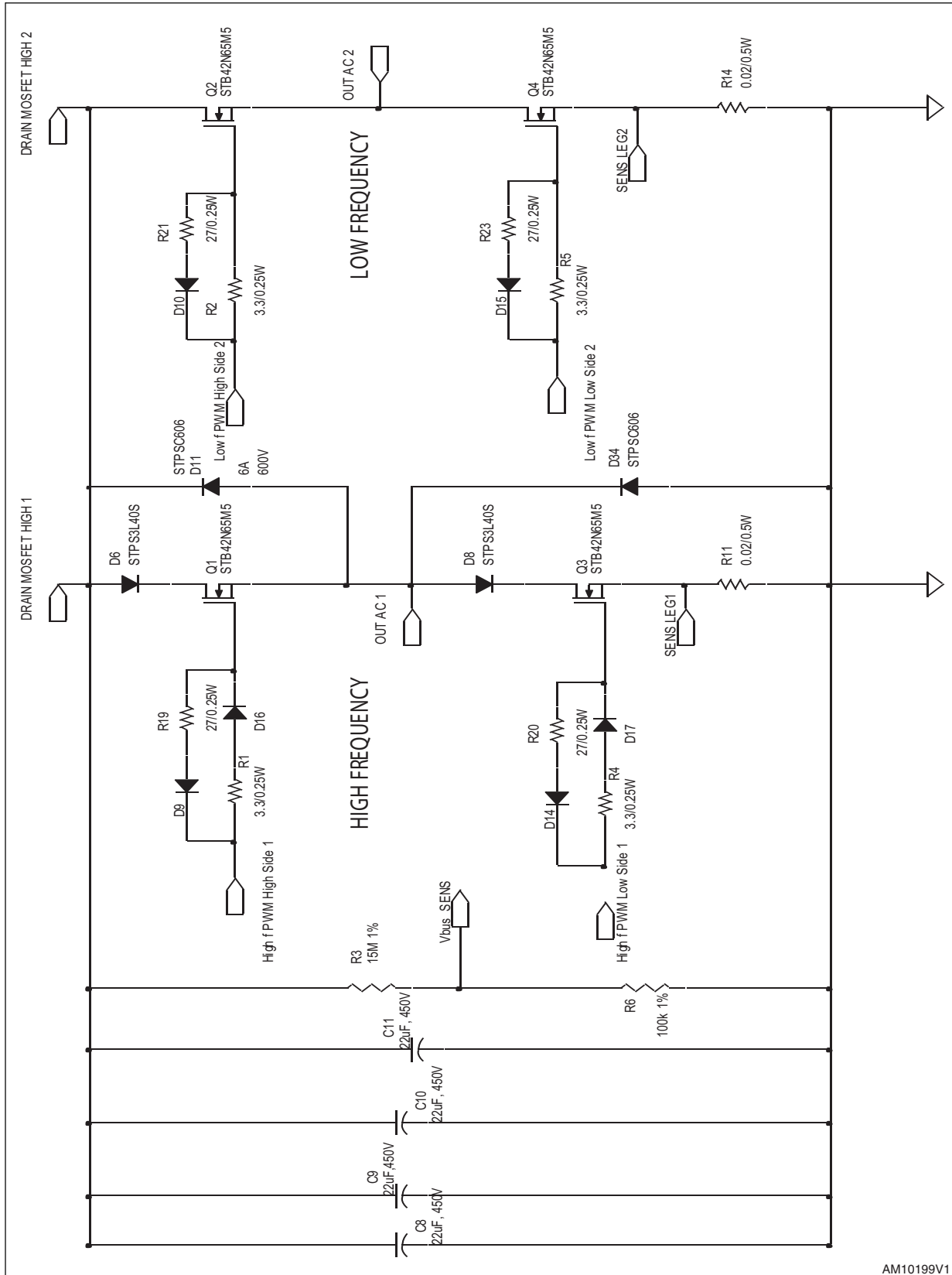

Figure 8. DC/AC topology: mixed-frequency inverter



AM10199V1

Figure 9. Output AC line filter

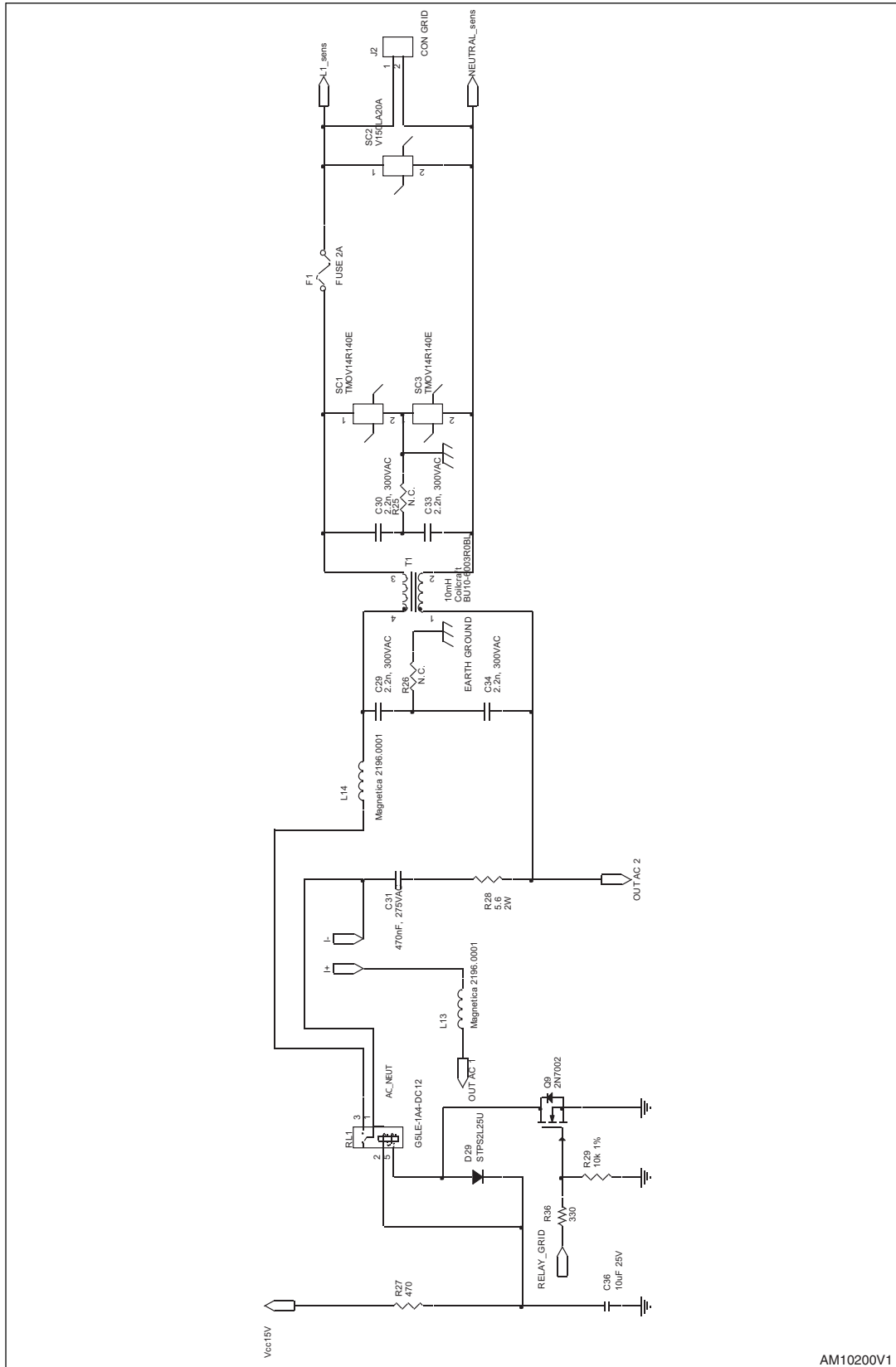

Figure 10. Output current sensor

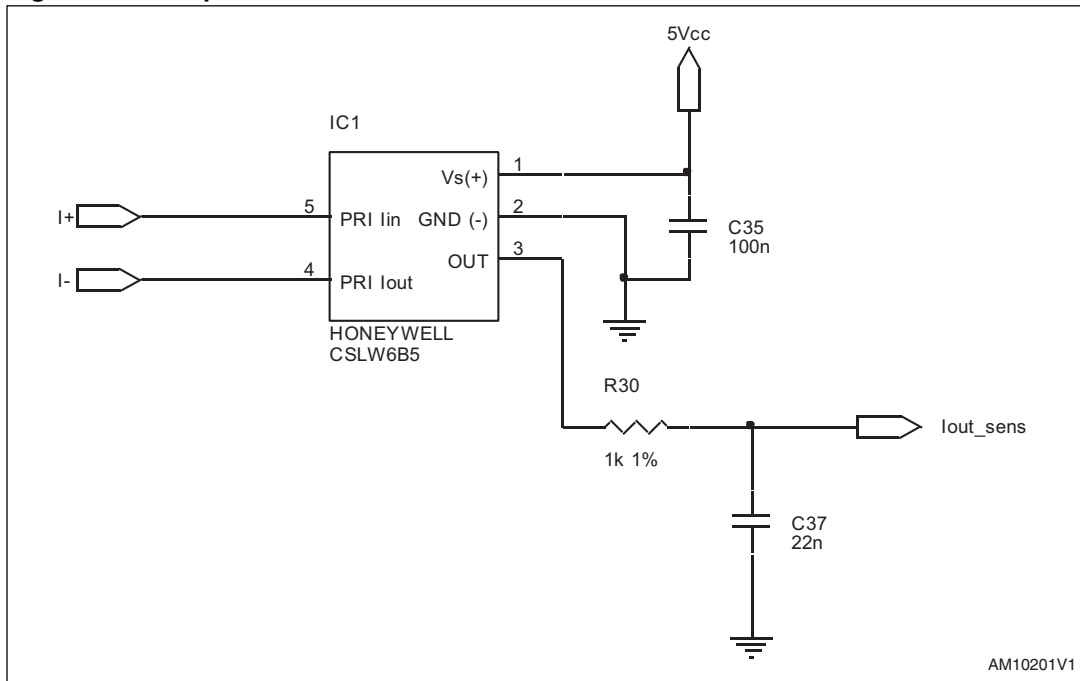

Figure 11. AC line current sensing

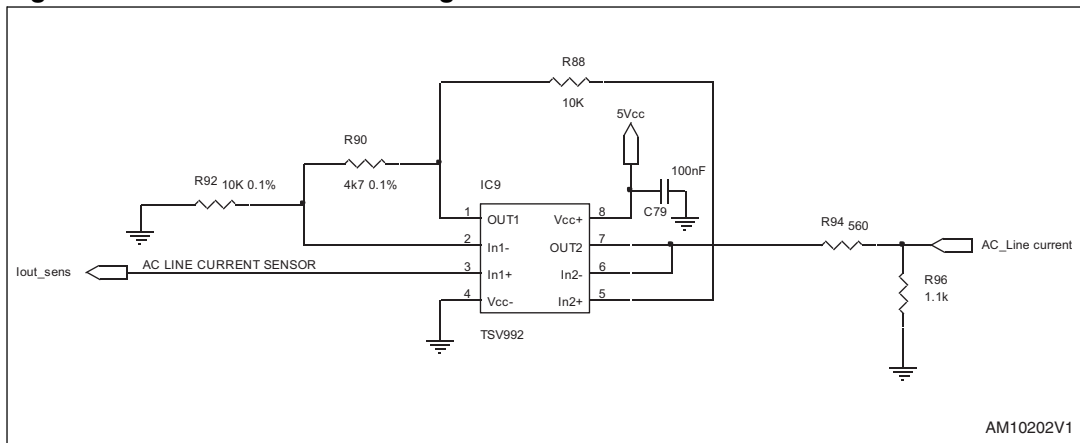
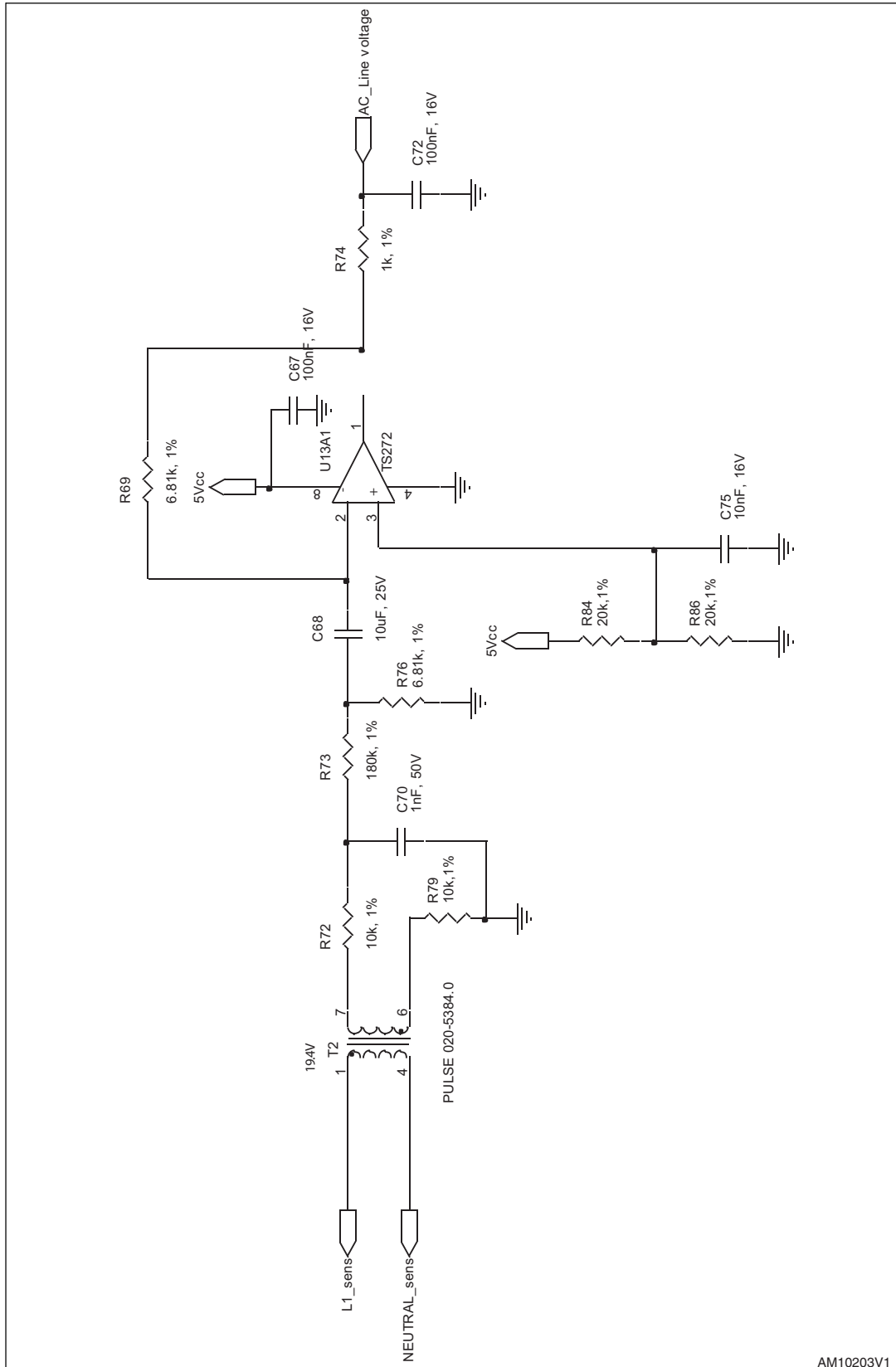

Figure 12. VOUT sensing section



AM10203V1



Figure 13. 32 bit MCU-STM32F electrical schematic

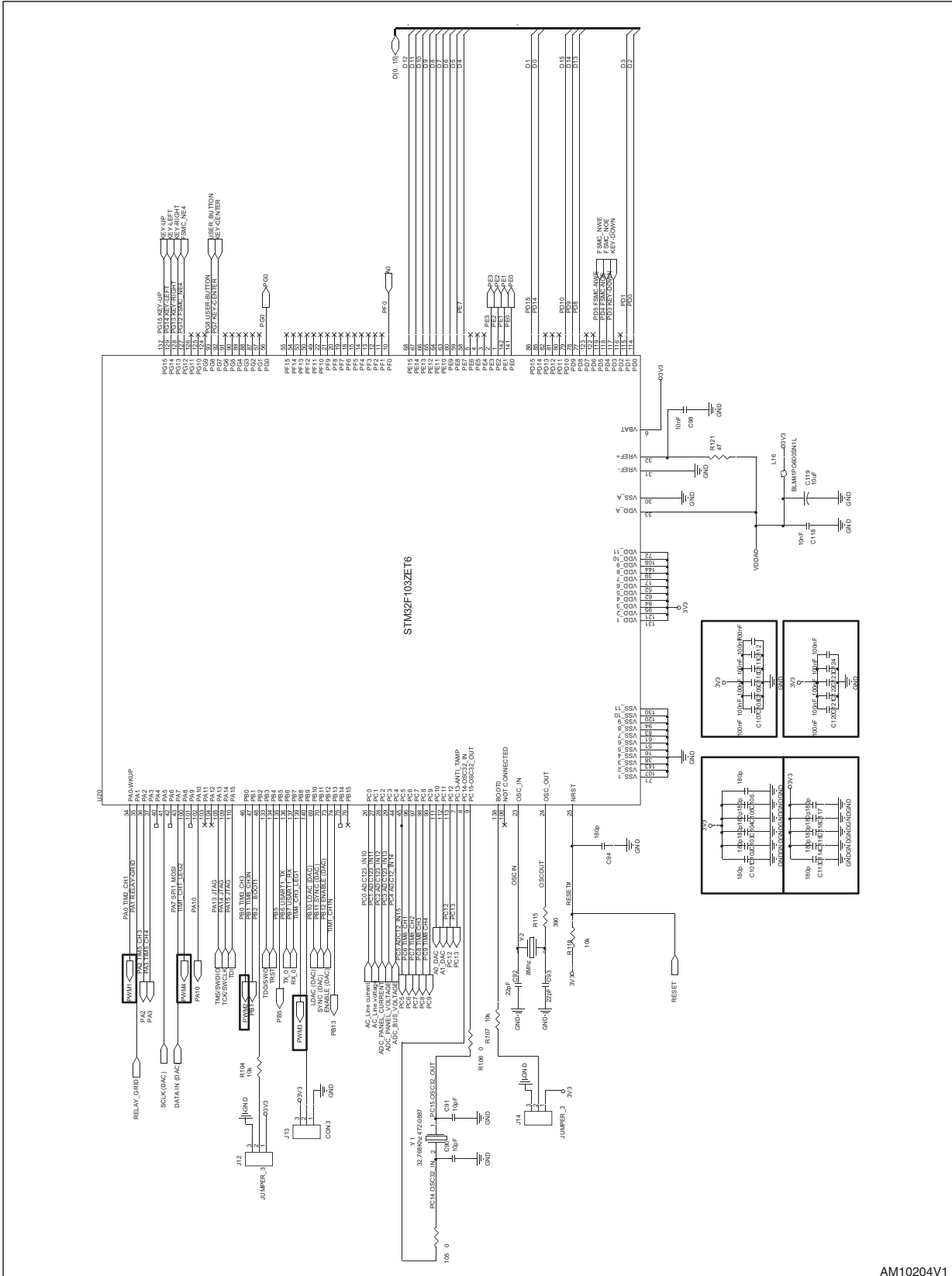

AM10204V1