

Devices Connected/Referenced

ADA4940-1/ADA4940-2	Single/Dual, Ultralow Power, Low Distortion Differential ADC Driver
AD7982	18-Bit, 1 MSPS PulSAR ADC
ADR395	Micropower, Low Noise, Precision 5 V Bandgap Voltage Reference

Ultralow Power, 18-Bit, Differential PulSAR ADC Driver

EVALUATION AND DESIGN SUPPORT

Design and Integration Files

[Schematics](#), [Layout Files](#), [Bill of Materials](#)

CIRCUIT FUNCTION AND BENEFITS

The circuit, shown in Figure 1, uses the ultralow power [AD7982](#) 18-bit, 1 MSPS ADC driven by the [ADA4940-1](#), a low power fully differential amplifier. The [ADR395](#), low noise precision 5.0 V voltage reference is used to supply the 5 V needed for the ADC. All the ICs shown in Figure 1 are available in small packages, either 3 mm × 3 mm LFCSP, or 3 mm × 5 mm MSOP, which helps reduce board cost and space.

Power dissipation of the [ADA4940-1](#) in the circuit is less than 9 mW. The 18-bit, 1 MSPS [AD7982](#) ADC consumes only 7 mW @ 1 MSPS, which is much lower than competitive ADCs available in the market. This power also scales with the throughput. The [ADR395](#) consumes only 0.7mW, making the total power dissipated by the system less than 17 mW.

CIRCUIT DESCRIPTION

Modern high resolution SAR ADCs, such as the [AD7982](#) 18-bit, 1 MSPS PulSAR® ADC, require a differential driver for optimum performance. In such applications, the ADC driver takes either a differential or single-ended signal and performs the level shifting required to drive the input of the ADC at the right level.

Figure 1 shows the [ADA4940-1](#) differential amplifier level shifting and driving the 18-bit [AD7982](#) differential input successive approximation PulSAR ADC. Using four resistors, the [ADA4940-1](#) can either buffer the signal with a gain = 1 or amplify the signal for more dynamic range. The ac and dc performances are compatible with those of the 18-bit, 1 MSPS [AD7982](#) PulSAR® ADC and other 16- and 18-bit members of the family, which have sampling rates up to 2 MSPS. This circuit can also accept a single-ended input signal to generate the same fully differential output signal.

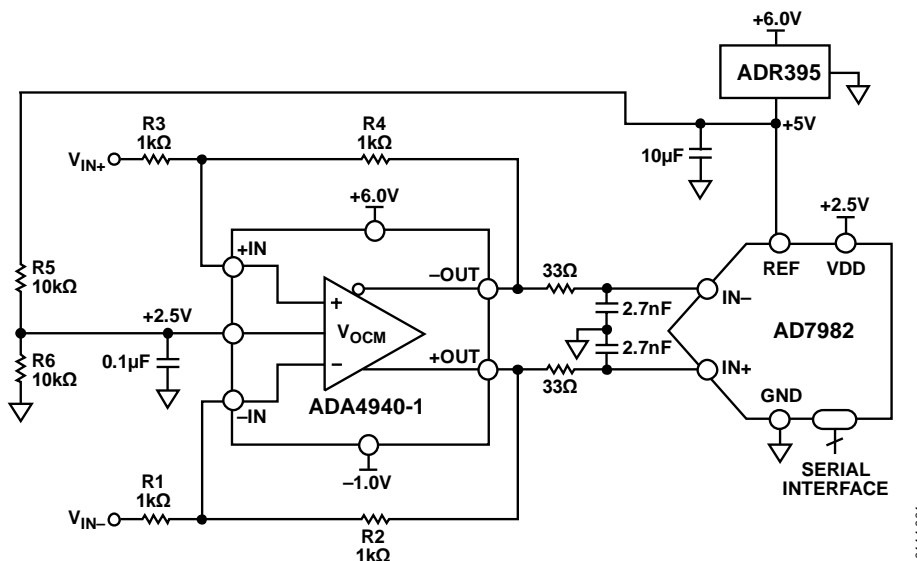

Figure 1. High Performance 18-Bit Differential ADC Driver (Simplified Schematic: All Connections and Decoupling Not Shown)

Rev.0

Circuits from the Lab™ circuits from Analog Devices have been designed and built by Analog Devices engineers. Standard engineering practices have been employed in the design and construction of each circuit, and their function and performance have been tested and verified in a lab environment at room temperature. However, you are solely responsible for testing the circuit and determining its suitability and applicability for your use and application. Accordingly, in no event shall Analog Devices be liable for direct, indirect, special, incidental, consequential or punitive damages due to any cause whatsoever connected to the use of any Circuits from the Lab circuits. (Continued on last page)

The AD7982 operates on a single VDD supply of 2.5 V. It contains a low power, high speed, 18-bit sampling ADC and a versatile serial interface port. The reference voltage (REF) is applied externally from the ADR395 precision low dropout (0.3 V) band gap reference, and can be set independently of the supply voltage. The ADA4940-1 is dc coupled on the input and the output and performs a differential or single-ended-to-differential conversion if needed. It also buffers the driving signal. A single-pole 1.8 MHz R-C (33 Ω , 2.7 nF) noise filter is placed between the op amp output and the ADC input. The filter also provides some isolation between the op amp output and the switching spikes at the ADC input due to the internal sample-and-hold function.

The ADA4940-1 is driven with a 7 V supply (+6 V and -1 V) in order to provide sufficient headroom on the outputs, which must swing from 0 V to +5 V for a full-scale input to the ADC.

The gain is set by the ratio of the feedback resistor ($R_2 = R_4$) to the gain resistor ($R_1 = R_3$). In addition, the circuit can be used to convert either single-ended or differential inputs to a differential output. If needed, a termination resistor in parallel with the input can be used. Whether the input is a single-ended input or differential input, the input impedance of the amplifier can be calculated as show in the MT-076 Tutorial and in the DiffAmpCalc™ Differential Amplifier Calculator (www.analog.com/diffampcalc).

If $R_1 = R_2 = R_3 = R_4 = 1 \text{ k}\Omega$, the single-ended input impedance is approximately 1.33 k Ω . An external 52.3 Ω termination resistor provides a 50 Ω termination for the source. An additional 25.5 Ω (1025.5 Ω total) at the inverting input balances the parallel impedance of the 50 Ω source and the termination resistor driving the noninverting input (52.3 $\Omega \parallel 50 \Omega = 25.5 \Omega$). However, if a differential source input is used, the differential input impedance is 2 k Ω . In this case, two 52.3 Ω termination resistors are used to terminate each input if needed.

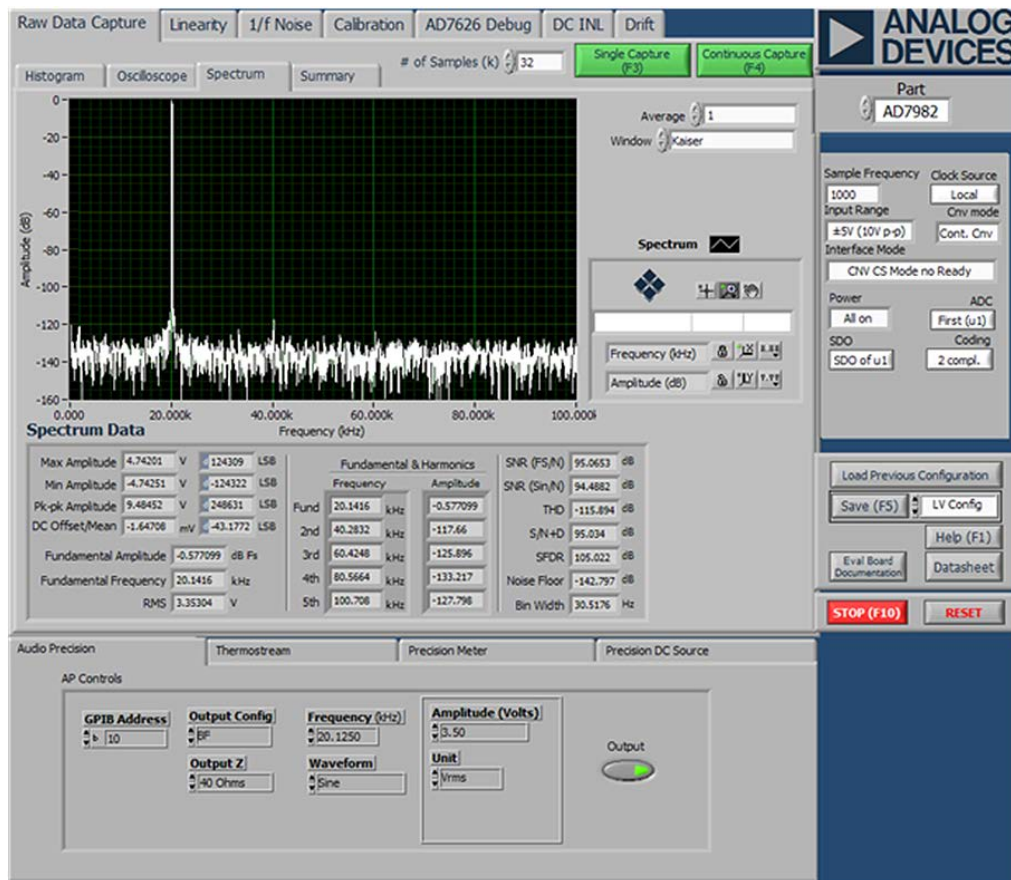

Figure 2. FFT Plot (32,000 Point) for 20 kHz Signal, 0.5 dB Below Full Scale, with Sampling Frequency of 1 MSPS

For the tests on this circuit, the signal generator provided a 10 V p-p differential output. The V_{OCM} input is bypassed for noise reduction and set externally with 1% resistors to maximize the output dynamic range on the 5 V reference. With an output common-mode voltage of 2.5 V, each ADA4940-1 output swings between 0 V and 5 V, opposite in phase, providing a gain of 1 and a 10 V p-p differential signal to the ADC input.

The FFT performance is shown in Figure 2 and is summarized as follows:

- SNR = 95.06 dBFS (excluding harmonics)
- SINAD = 95.03 dBFS
- SFDR = 105.02 dBFS
- THD = -115.89 dBFS

The INL and DNL performance are shown in Figure 3.

COMMON VARIATIONS

The circuit is proven to work with good stability and accuracy with component values shown. Other analog-to-digital

converters can be used in place of the ADA4940-1 to achieve the maximum desired performance. The ADA4940-1/ADA4940-2 is optimum for driving 16-bit and 18-bit ADCs with minimal degradation in performance. Faster sampling 18-bit ADCs include the AD7984 (1.33 MSPS) and AD7986 (2 MSPS). Differential 16-bit ADCs include the AD7688 (500 kSPS) and the AD7693 (500 kSPS).

The ADA4940-1/ADA4940-2 rail-to-rail outputs can be driven to within 0.5 V of each power rail without significant ac performance degradation. Other differential ADC drivers such as the AD8137 and ADA4941-1 can also be used to replace the ADA4940-1 for other applications when speed, input impedance, or other factors dictate.

CIRCUIT EVALUATION AND TEST

This circuit was tested using a modified EVAL-AD7982SDZ PulSAR AD7982 evaluation board connected to the converter evaluation and development board (EVAL-CED1Z).

The AD7982 evaluation board was modified to accept the ADA4940-1 differential ADC driver and the ADR395 reference.

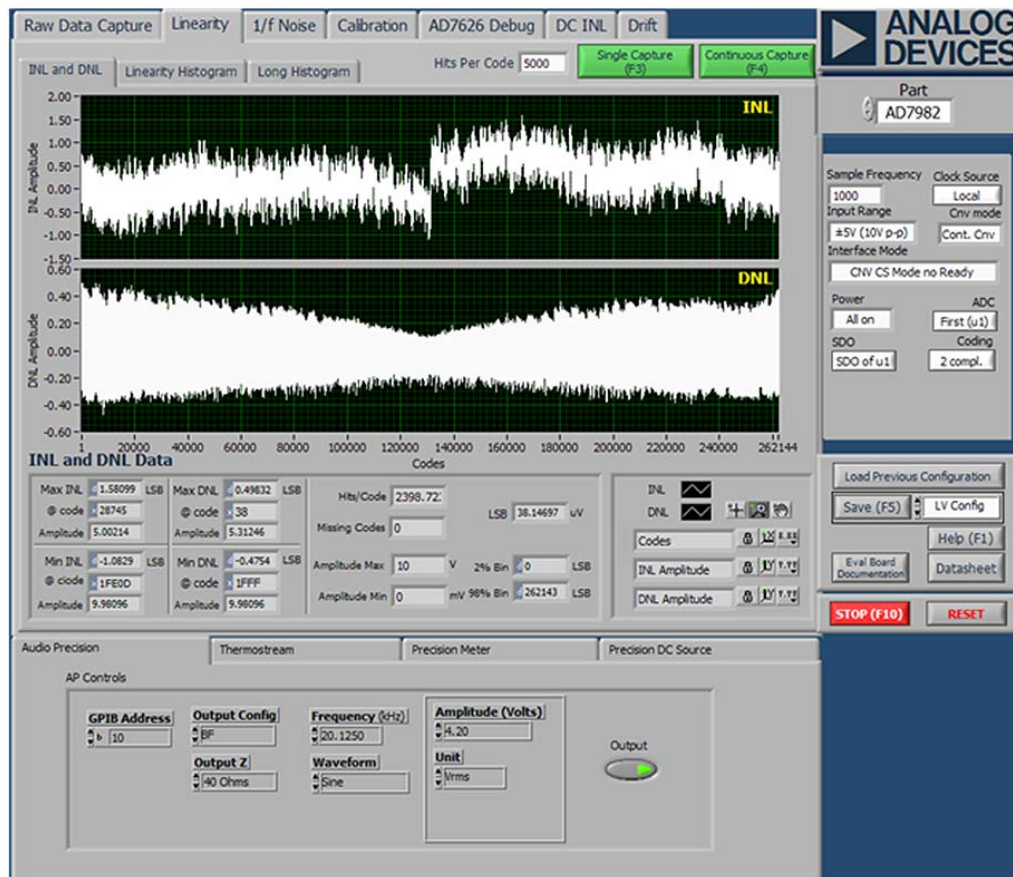

Figure 3. INL and DNL Plot for 20 kHz Signal, with Sampling Frequency of 1 MSPS

The **EVAL-AD7982SDZ** is a customer evaluation board intended to ease standalone testing of performance and functionality for the 18-bit **AD7982** PulSAR ADC.

The **EVAL-CED1Z** board is a platform intended for use in evaluation, demonstration, and development of systems using Analog Devices precision converters. It provides the necessary communications between the converter and the PC,

programming or controlling the device, transmitting or receiving data over a USB link as shown in Figure 4 and Figure 5.

Equipment Needed

In addition to the two evaluation boards, the external power supplies of +6 V and -1 V were required for the **ADA4940-1**. A "wall wart" supplied the +7.5 V dc voltage for the **EVAL-CED1Z**. Other appropriate voltages were supplied to the **AD7982** evaluation board from the **EVAL-CED1Z**.

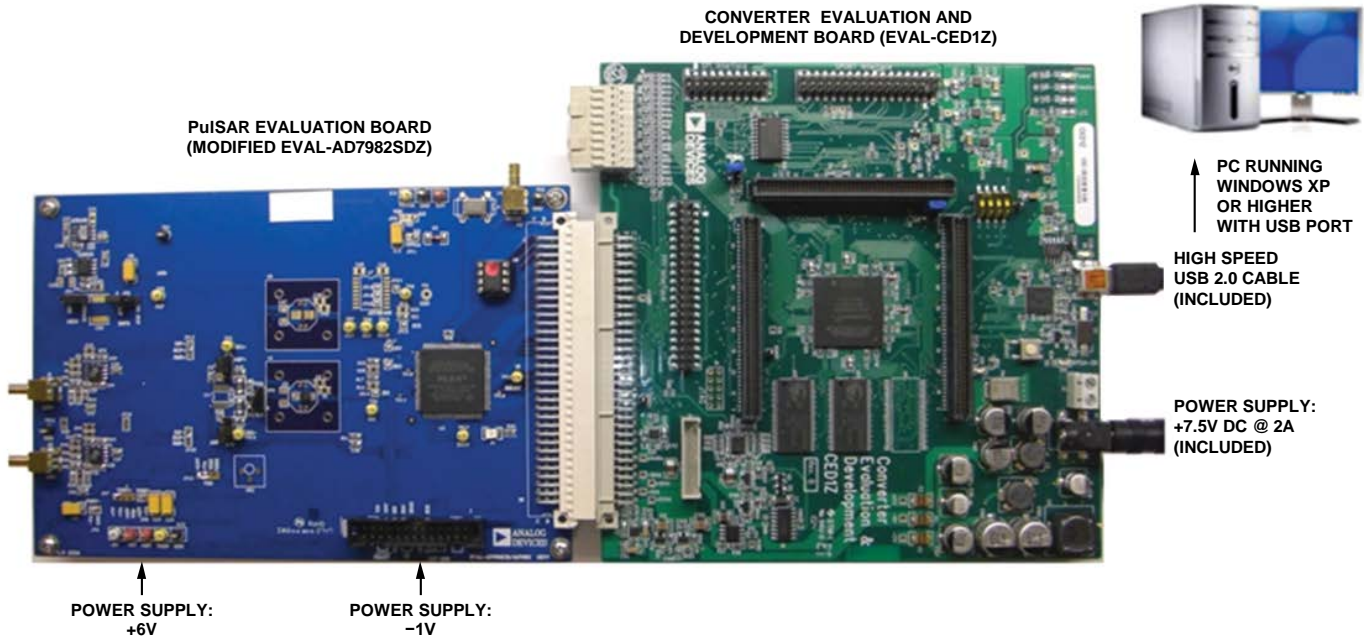

Figure 4. PuSAR ADC Evaluation Platform

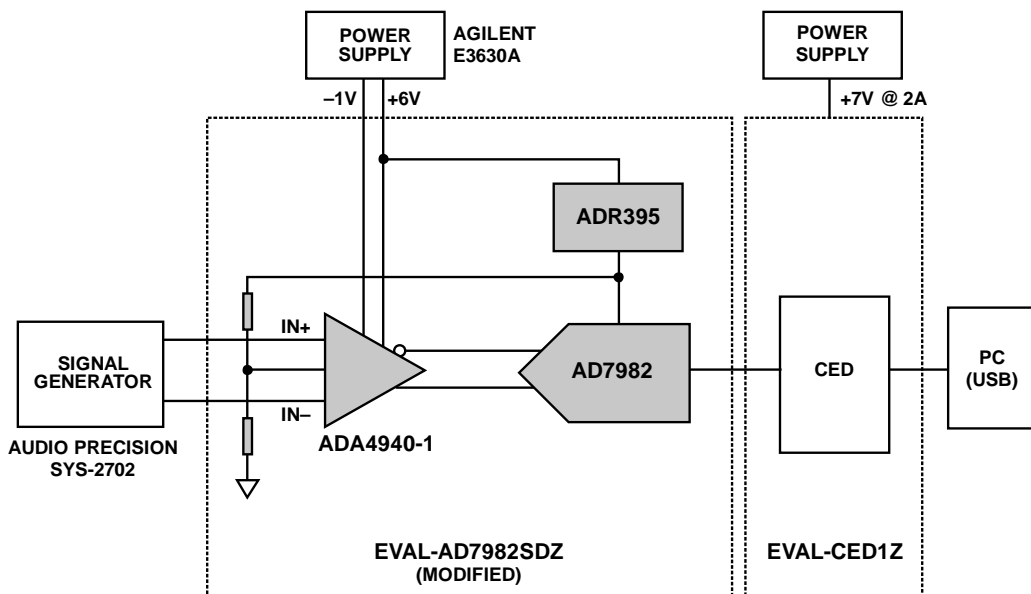

Figure 5. Test Setup Functional Block Diagram

A low distortion signal source, the Audio Precision® SYS-2702, was used to achieve the required performance. A PC with Windows® XP or Windows 7 equipped with an USB port was used to run the PulSAR evaluation software.

Getting Started

The software was installed as described at

www.analog.com/EVAL-CED1Z, and

www.analog.com/AD7982_adc_EVAL-CED1Z

The modified [AD7982](#) evaluation board was connected to the [EVAL-CED1Z](#). The +7.5 V wall wart was connected to the [EVAL-CED1Z](#). The external power supplies of +6 V and –1 V were connected to the [AD7982](#) evaluation board.

Setup and Test

An Audio Precision SYS-2702 source was used to provide the input signal to the [AD7982](#) evaluation board. The PulSAR evaluation software, which is LabVIEW® based, was used to control the Audio Precision input signals and also to monitor the ADC inputs and output.

The software allows the collection and processing of INL, DNL, and FFT data as shown in Figure 2, Figure 3, and Figure 4.

LEARN MORE

CN-0237 Design Support Package:

www.analog.com/CN0237-DesignSupport

DiffAmpCalc: Differential Amplifier Calculator:

www.analog.com/diffampcalc

Ardizzoni, John. *A Practical Guide to High-Speed Printed-Circuit-Board Layout*, Analog Dialogue 39-09, September 2005.

MT-031 Tutorial, *Grounding Data Converters and Solving the Mystery of "AGND" and "DGND"*, Analog Devices.

MT-074 Tutorial, *Differential Drivers for Precision ADCs*, Analog Devices.

MT-075 Tutorial, *Differential Drivers for High Speed ADCs Overview*, Analog Devices.

MT-076 Tutorial, *Differential Driver Analysis*, Analog Devices.

MT-101 Tutorial, *Decoupling Techniques*, Analog Devices.

Data Sheets and Evaluation Boards

[ADA4940-1 Data Sheet](#)

[ADA4940-2 Data Sheet](#)

[ADA4940 Evaluation Board](#)

[AD7982 Data Sheet](#)

[AD7982 Evaluation Board](#)

[ADR395 Data Sheet](#)

REVISION HISTORY

10/10—Revision 0: Initial Version

(Continued from first page) Circuits from the Lab circuits are intended only for use with Analog Devices products and are the intellectual property of Analog Devices or its licensors. While you may use the Circuits from the Lab circuits in the design of your product, no other license is granted by implication or otherwise under any patents or other intellectual property by application or use of the Circuits from the Lab circuits. Information furnished by Analog Devices is believed to be accurate and reliable. However, "Circuits from the Lab" are supplied "as is" and without warranties of any kind, express, implied, or statutory including, but not limited to, any implied warranty of merchantability, noninfringement or fitness for a particular purpose and no responsibility is assumed by Analog Devices for their use, nor for any infringements of patents or other rights of third parties that may result from their use. Analog Devices reserves the right to change any Circuits from the Lab circuits at any time without notice but is under no obligation to do so.

©2011 Analog Devices, Inc. All rights reserved. Trademarks and registered trademarks are the property of their respective owners.
CN10144-0-10/11(0)



www.analog.com