

Devices Connected/Referenced

AD7691	18-Bit 1.5 LSB INL, 250 kSPS PuLSAR ADC
AD8597	Ultralow Distortion, Ultralow Noise Amplifier
ADR435	Ultralow Noise XFET 5 V Reference

Optimizing AC Performance in an 18-bit, 250 kSPS, PuLSAR Measurement Circuit

EVALUATION AND DESIGN SUPPORT

Circuit Evaluation Boards

[CN-0261 Circuit Evaluation Board \(EVAL-CN0261-SDPZ\)](#)

[System Demonstration Platform \(EVAL-SDP-CB1Z\)](#)

Design and Integration Files

[Schematics, Layout Files, Bill of Materials](#)

CIRCUIT FUNCTION AND BENEFITS

Choosing complementary products for high performance ADCs can be a challenge. The circuit in Figure 1 shows a complete front end solution for the 18-bit, 250 kSPS PuLSAR® ADC, which is optimized for ac performance.

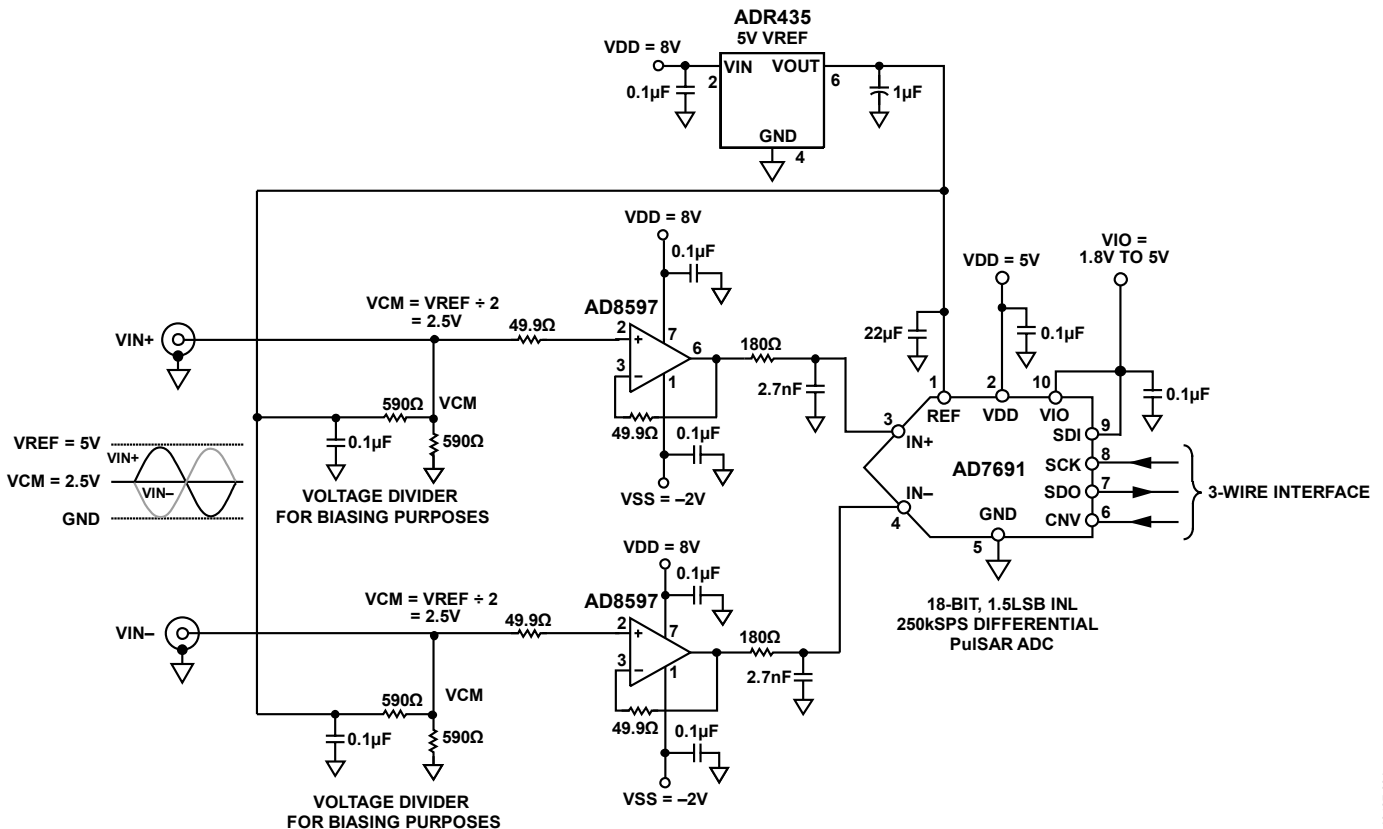

Figure 1. High Performance, 18-Bit ADC Front End (Simplified Schematic: All Connections and Decoupling Not Shown)

Rev.0

Circuits from the Lab™ circuits from Analog Devices have been designed and built by Analog Devices engineers. Standard engineering practices have been employed in the design and construction of each circuit, and their function and performance have been tested and verified in a lab environment at room temperature. However, you are solely responsible for testing the circuit and determining its suitability and applicability for your use and application. Accordingly, in no event shall Analog Devices be liable for direct, indirect, special, incidental, consequential or punitive damages due to any cause whatsoever connected to the use of any Circuits from the Lab circuits. (Continued on last page)

The circuit centers on the [AD7691](#), which is a low power ADC (1.35 mW @ 2.5 V and 100 kSPS) from the PulSAR family. The ADC is driven directly from the [AD8597](#) ultralow distortion, ultralow noise amplifier, and the ADC's reference is the ultralow noise 5 V [ADR435](#). The circuit achieves 101 dB SNR and 118 dB THD with a 1 kHz input tone.

CIRCUIT DESCRIPTION

The heart of this circuit is the [AD7691](#), an 18-bit, 250 kSPS charge redistribution, successive approximation, analog-to-digital converter (ADC) that operates from a single power supply.

It contains a low power, high speed, 18-bit sampling ADC with no missing codes, an internal conversion clock, and a versatile serial interface port. On the CNV rising edge, it samples the voltage difference between the IN+ and IN- pins. The voltages on these pins swing in opposite phases between 0 V and REF. The reference voltage, REF, is applied externally and can be set up to the supply voltage. The [AD7691](#) power scales linearly with throughput.

For the experiments carried out for this circuit note, the [AD7691](#) was interfaced to the SDP (System Demonstration Platform board, EVAL-SDP-CB1Z), and the ADC SPI-compatible serial interface was connected to the DSP SPORT interface VIO supply.

The [AD7691](#) is housed in a 10-lead MSOP or a 10-lead QFN (LFCSP).

The ADC is driven from the [AD8597](#) (4.8 mA/amplifier), which is a low noise, low distortion operational amplifiers ideal for use as an input buffer. The low noise of 1.1 nV/√Hz and low harmonic distortion of less than -120 dB at audio frequencies give the [AD8597](#) the wide dynamic range necessary for preamplifiers in audio, medical, and instrumentation applications. The excellent slew rate of 14 V/μs and 10 MHz gain bandwidth product make it highly suitable for medical applications.

The [AD8597](#) can be operated on supply voltages up to ±15 V. In the circuit, supply voltages of +8 V and -2 V were chosen in order to minimize power dissipation.

The [AD8597](#) is available in 8-lead SOIC and LFCSP packages. The 180 Ω resistors and the 2.7 nF capacitors form a single-pole 327 kHz low-pass filter to further reduce noise.

The voltage reference used in this application is the [ADR435](#), which is one of a family of XFET® voltage references featuring low noise, high accuracy, and low temperature drift performance. Using patented temperature drift curvature correction and XFET (eXtra implanted junction FET) technology, voltage change vs. temperature is minimized.

The [ADR43x](#) family can source up to 30 mA of output current and sink up to 20 mA. It also has a trim terminal to adjust the output voltage over a 0.5% range without compromising performance.

The [ADR435](#) is available in either an 8-lead MSOP or an 8-lead narrow SOIC package.

The dynamic performance of the above configuration is shown in Figure 2 and Figure 3 and is summarized below:

- SNR = 101.02dB
- THD = 118.44 dB
- SINAD = 100.94 dB
- Dynamic Range = 101.5 dB

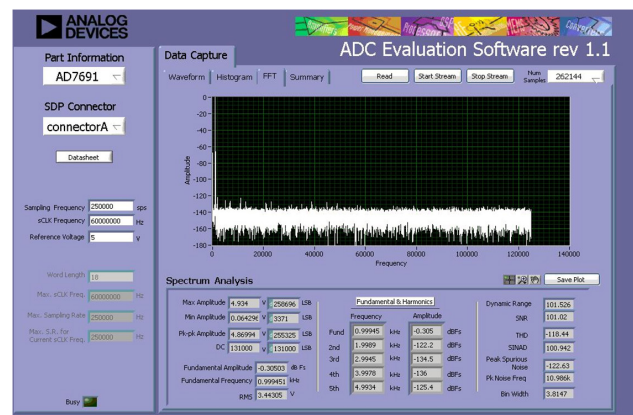

Figure 2. Evaluation Board Software Output Screen Capture

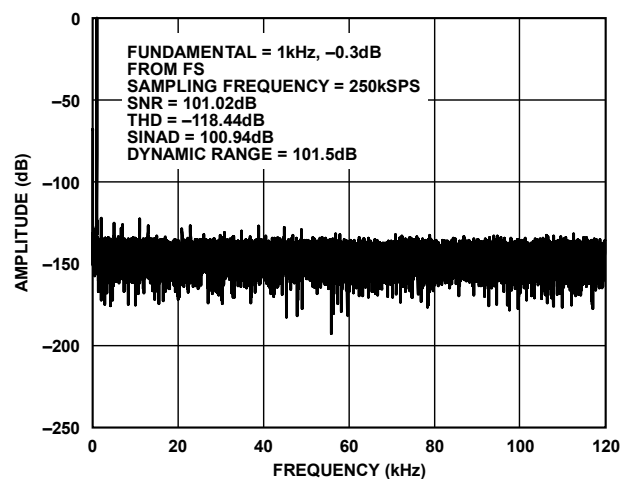

Figure 3. FFT Details for 1 kHz Tone Sampling at 250 kSPS

COMMON VARIATIONS

Other pin-compatible 18-bit ADCs in the PulSAR family are available with higher sampling rates: [AD7690](#) (400 kSPS), [AD7982](#) (1 MSPS), [AD7984](#) (1.33 MSPS).

The [AD7986](#) (2 MSPS) is available in 20-lead 4 mm × 4 mm LFCSP (QFN).

The [AD8599](#) op amp is a dual version of the [AD8597](#) and can be used in the circuit, if desired.

The [ADA4841-1](#) (single) and [ADA4841-2](#) (dual) are lower power op amps (1.1 mA/amp), but have slightly higher noise (2.1 nV/√Hz).

The [ADA4941](#) is optimized for driving differential input 18-bit ADCs and has 2.2 mA/amplifier and 10.2 nV/√Hz noise.

A summary of PulSAR ADCs and recommended drivers can be found at www.analog.com/PulSAR.

Other reference voltages within the [ADR43x](#) family or from other reference families are available from the Analog Devices portfolio.

The inclusion of a buffer to create the VCM signal to bias the input would be normal, however, specified performance was achieved without the need of a buffer in this circuit.

CIRCUIT EVALUATION AND TEST

Equipment Needed (Equivalents Can Be Substituted)

- [EVAL-CN0261-SDPZ](#) circuit evaluation board
- System Demonstration Board ([EVAL-SDP-CB1Z](#))
- Function generator, Audio Precision SYS-2522
- External 10 nF ceramic filter capacitor as shown in Figure 4
- Power supplies: +8 V @ 50 mA, -2 V @ 50 mA, +5 V @ 500 mA.
- PC with a USB port and Windows® XP or Windows Vista® (32-bit), or Windows® 7 (32-bit)

Setup and Test

The block diagram of ac performance measurement setup is shown in Figure 4. The [EVAL-CN0261-SDPZ](#) board is driven with bench supplies as shown. Complete documentation for the board can be found at www.analog.com/CN0261-DesignSupport.

To measure the frequency response, the equipment was connected as shown in Figure 5. The Audio Precision SYS-2522 was set to output a 1 kHz tone at an input signal level of 0.5 dB below full-scale. The external 10 nF capacitor acts as a low-pass noise reduction filter for the output of the signal generator. Using the evaluation board software, the FFT data was then captured and analyzed.

The software analysis is part of the evaluation board software, which allows the user to capture and analyze ac or dc performance.

In addition to ac performance, the evaluation board software also allows users to analyze the waveform data and create a histogram for the measured input signal.

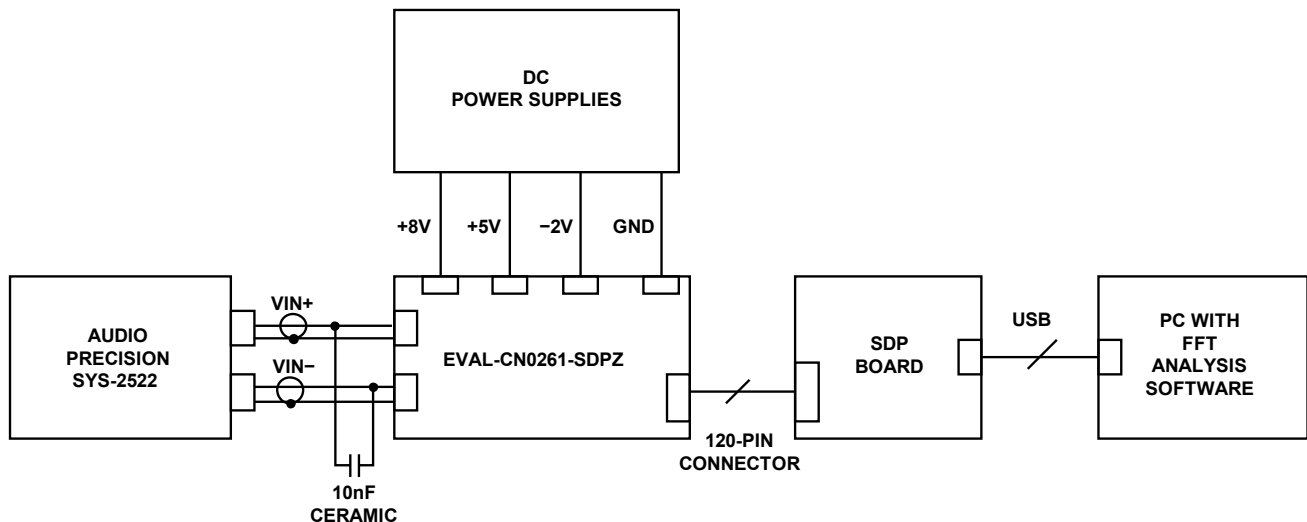

Figure 4. Test Setup for Measuring AC Performance

LEARN MORE

CN0261 Design Support Package:

www.analog.com/CN0261-DesignSupport

Ardizzoni, John. *A Practical Guide to High-Speed Printed-Circuit-Board Layout*, Analog Dialogue 39-09, September 2005.

MT-021 Tutorial, *Successive Approximation ADCs*, Analog Devices.

MT-031 Tutorial, *Grounding Data Converters and Solving the Mystery of "AGND" and "DGND,"* Analog Devices.

MT-101 Tutorial, *Decoupling Techniques*, Analog Devices.

Voltage Reference selection and Evaluation Tool, Analog Devices.

Data Sheets and Evaluation Boards

CN-0261 Circuit Evaluation Board (EVAL-CN0261-SDPZ)

System Demonstration Platform (EVAL-SDP-CB1Z)

AD7691 Data Sheet

AD8597 Data Sheet

ADR435 Data Sheet

REVISION HISTORY

1/12—Revision 0: Initial Version

(Continued from first page) Circuits from the Lab circuits are intended only for use with Analog Devices products and are the intellectual property of Analog Devices or its licensors. While you may use the Circuits from the Lab circuits in the design of your product, no other license is granted by implication or otherwise under any patents or other intellectual property by application or use of the Circuits from the Lab circuits. Information furnished by Analog Devices is believed to be accurate and reliable. However, "Circuits from the Lab" are supplied "as is" and without warranties of any kind, express, implied, or statutory including, but not limited to, any implied warranty of merchantability, noninfringement or fitness for a particular purpose and no responsibility is assumed by Analog Devices for their use, nor for any infringements of patents or other rights of third parties that may result from their use. Analog Devices reserves the right to change any Circuits from the Lab circuits at any time without notice but is under no obligation to do so.

©2012 Analog Devices, Inc. All rights reserved. Trademarks and registered trademarks are the property of their respective owners.
CN10467-0-1/12(0)



www.analog.com