

DESIGN NOTES

Micropower Op Amps Work Down to 1.8V Total Supply, Guaranteed over Temperature – Design Note 414

Glen Brisebois

Introduction

Micropower op amps extend the run time of battery-powered systems and reduce energy consumption in other energy limited systems. Nevertheless, battery voltages change as they are depleted. To maximize a system's run time, op amps should operate over a wide enough supply range to make use of the complete range of battery voltages, from fully charged to fully depleted. The new LT[®]6000 family of 1 μ A and 13 μ A op amps operates on supplies as high as 16V all the way down to 1.8V, guaranteed over temperature.

NiMH and Alkaline

A NiMH battery has a nominal cell voltage of 1.2V, but it depletes to 0.9V, below which the voltage rapidly falls off. The LT6000 family of op amps works directly from two series NiMH cells taking full advantage of their entire charge discharge cycle. Likewise, an alkaline battery has a nominal cell voltage of 1.5V, but can deliver energy down to depletion levels of a few hundred millivolts. So, the LT6000 can happily operate from two series alkaline cells, and just as well operate directly from a 9V alkaline battery (6 series cells) from full charge all the way down to very extreme depletions (300mV average cell voltage for 1.8V total). Sure, other low voltage op amps can operate at the depleted end of this battery range, but few of those can also tolerate a 9V supply.

Supply Friendliness

Some micropower op amps have annoying properties such as drawing excessive current at start-up (commonly called carrots) or when the output hits a supply rail. These current spikes defeat the purpose of the micropower operation by hastening battery discharge. Worse yet, they may altogether prevent the supply from coming up in the case of a current limited supply, effectively crowbaring the system. Figure 1 shows the LT6000 and LT6003 supply current vs applied supply voltage at various temperatures. The LT6000 family eliminates carrots or at least chews them down to stumps.

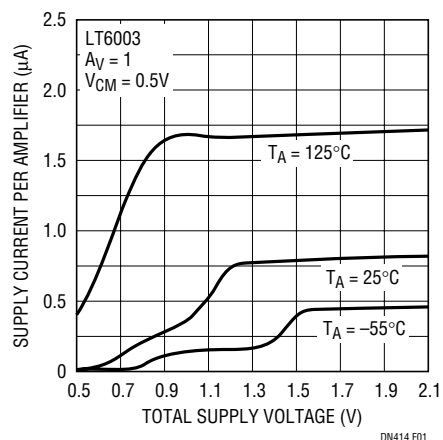
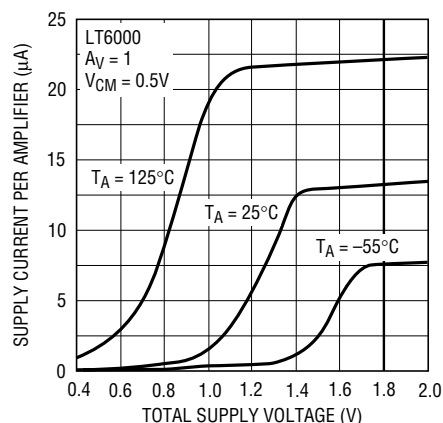

Figure 1. Clean Start-Up Characteristics Without Current Spikes

Portable Gas Sensor

Figure 2 shows the LT6003 applied as an oxygen sensor amplifier. The oxygen sensor acts much like an air powered battery, and generates 100 μ A in one atmosphere of fresh air (20.9% oxygen). It is designed to operate into a 100 Ω resistor, for a 10mV full-scale reading. The op amp amplifies this voltage with a gain of 100 as shown (101 actually), for a 1V full-scale output. In terms of

LT, LTC, LT and LTM are registered trademarks of Linear Technology Corporation. All other trademarks are the property of their respective owners.

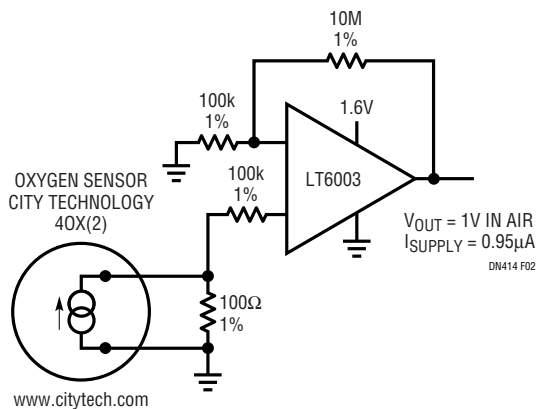

Figure 2. Micropower Oxygen Sensor

monitoring environments for adequate human-livable oxygen levels, 18% oxygen content translates to an output voltage of 0.86V. Oxygen contents below this are considered hazardous. Oxygen deprivation in the lungs causes immediate loss of consciousness and bears no resemblance to holding your breath. Total supply current for the circuit is 950nA. The 500μV worst-case input offset voltage at room temperature contributes a 50mV uncertainty in the output reading.

Better low value accuracy can be obtained by implementing a transimpedance approach as shown in Figure 3. Op amp A1 provides a buffered reference voltage so the circuit is accurate all the way down to a zero-oxygen environment without clipping at ground. Op amp A2 provides the current-to-voltage function through feedback resistor R_F . The sensor still sees the 100Ω termination, as the manufacturer specifies. The output voltage is still 1V in normal atmosphere, but note that the noise gain is not much higher than unity so the output error due to offset is now 500μV worst case instead of the 50mV of the previous circuit. This considerable improvement in accuracy exacts some price in supply current, because the oxygen sensor

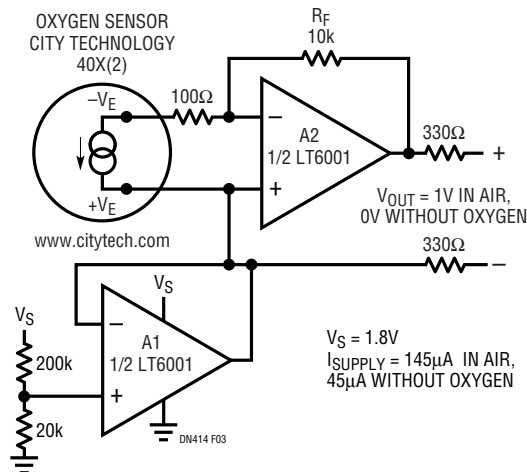

Figure 3. High Accuracy Oxygen Sensor

current is now provided back through R_F by the op amp output, which necessarily takes it from the supply. The supply current is therefore oxygen-presence dependant. Nevertheless, this solution is still ultralow power when monitoring environments that are oxygen-free by design, such as environments for food storage and those designed to inhibit combustion. It would also be ideal for portable sensors where the detected substance is not oxygen but is rather a hostile substance, which is not normally present and is therefore usually low current.

Conclusion

The LT6000 and LT6003 family of op amps offer 13μA and 1μA micropower operation over a wide supply range from 18V all the way down to 1.8V, guaranteed over temperature. Careful attention was paid during the design phase to minimizing gotchas such as supply current carrots. They are ideal for maximizing battery life in portable applications, operating over a wide range of battery charge levels and environments.

Data Sheet Download

www.linear.com

For applications help,
call (408) 432-1900, Ext. 3755