

# DESIGN NOTES

## µModule Buck-Boost Regulators Offer a Simple and Efficient Solution for Wide Input and Output Voltage Range Applications

Design Note 438

Jian Yin and Eddie Beville

### Introduction

An increasing number of applications require DC/DC converters that produce an output that falls somewhere within the input voltage range. The problem is that conventional buck-boost converter topologies, such as SEPIC or boost followed by buck, are complex, inefficient and consume a relatively large board area. Linear Technology offers 4-switch-topology buck-boost regulators that significantly improve efficiency and save space, but a complete regulator design still requires a number of external components and meticulous board layout decisions related to electrical and thermal considerations. The next clear step to simplify the design is a modular approach—a buck-boost regulator system in an IC form factor. The LTM4605 and LTM4607 µModule™ buck-boost regulators take that approach. Each requires only one external inductor and a single sensing resistor to produce a compact, high performance, high efficiency buck-boost regulator with exceptional thermal performance.

### High Efficiency

The LTM4605 and LTM4607 are high efficiency switch mode buck-boost power supply modules. The LTM4605 can operate over an input voltage range of 4.5V to 20V and support any output voltage within the range of 0.8V to 16V, set by a single resistor. As shown in Figure 1, the LTM4607 supports 4.5V to 36V inputs and outputs of 0.8V to 16V. Both can provide 92% to 98% efficiency over the wide input range. This high efficiency design delivers up to 5A continuous current in boost mode (12A in buck mode). Only the inductor, sensing resistor, and bulk input and output capacitors are needed to finish the design. Figure 2 shows a typical LTM4605 application with an output of 12V at 5A. An optional RC snubber is added here to reduce switching noise for applications where radiated EMI noise is a concern.

### Low Profile Solution

These power modules are offered in a space saving and thermally enhanced 15mm × 15mm × 2.8mm LGA package. This low profile package can fit the back side of PC boards for many high density point-of-load applications. Their high switching frequency and current mode architecture enable a fast transient response to line and load changes without sacrificing stability. Both can be frequency synchronized with an external clock to reduce undesirable frequency harmonics. Fault protection comes in the form of overvoltage protection and foldback current protection.

### Smooth Transition and Circuit Simplicity

Both the LTM4605 and LTM4607 include the switching controller, four power FETs, compensation circuitry and support components. The 4-switch topology provides high efficiency in all three modes of operation—buck, buck-boost and boost—with a smooth transition between each.

LT, LTC and LTM are registered trademarks and µModule is a trademark of Linear Technology Corporation. All other trademarks are the property of their respective owners.

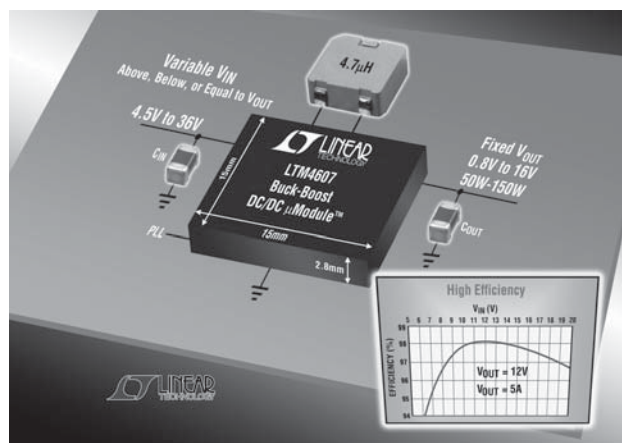

Figure 1. There is No Easier Way to Design a High Efficiency, High Power Density Buck-Boost Regulator than with the LTM4605 or LTM4607

Figure 2 shows an actual buck-boost design with external components chosen to satisfy the boost mode's 5A maximum load current. For buck-only applications, the maximum load current can be 12A at 12V<sub>OUT</sub> with the same external components. For instance in a buck-only configuration, such as in Figure 3, the load current can be increased up to 7A at 12V<sub>OUT</sub> for 168W capability. This application can achieve better than 98% efficiency as shown in Figure 4.

### Excellent Thermal Performance

The low profile LGA package has a low thermal resistance from junction to pin (4°C/W), thus maintaining an acceptable junction temperature even when satisfying high power requirements. Typically, operation in room temperature ambient conditions requires no special heat sinking or added airflow, but for warmer ambient environments or

high loads, simply add a heat sink to the top of the case for 2-sided cooling and add air flow to significantly lower the thermal resistance from junction to ambient. The data sheet provides more details about adding heat sinks and air flow considerations.

### Conclusion

There is no easier way to design an efficient high-density buck-boost converter than with the LTM4605 or LTM4607 μModule regulator. No design tricks are necessary to achieve efficiencies up to 98%—only one inductor, a single sensing resistor and bulk capacitance are required to complete a design. Low profile LGA packages fit on the back side of PCBs and have good thermal performance, enabling a 168W power output in an 8cm × 8.4cm 4-layer PCB. These devices are ideal for automotive, telecom, medical, motor drive and battery-powered applications.

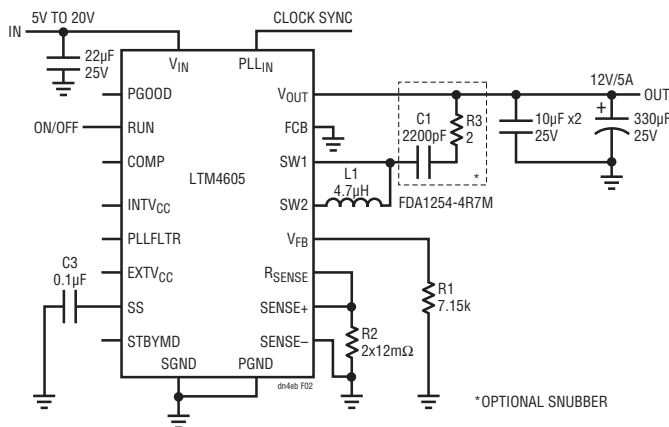

**Figure 2. Buck-Boost Converter Produces 12V<sub>OUT</sub> at 5A from a 5V to 20V Input Range**

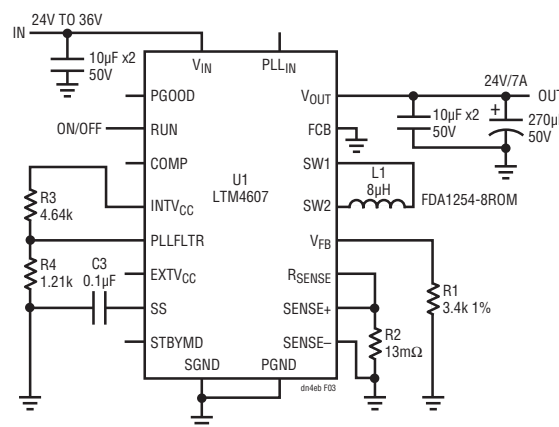

**Figure 3. Buck Converter Produces a 24V Output with 168W Capability**

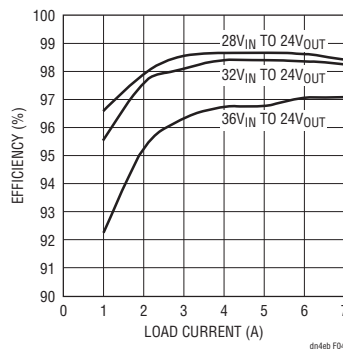

**Figure 4. Efficiency for the 24V<sub>OUT</sub> Converter in Figure 3**

[Data Sheet Download](#)

[www.linear.com/micromodule](http://www.linear.com/micromodule)

For applications help,  
call (408) 432-1900, Ext. 2593